



9010 TrackTill® Manual

OPERATOR'S / INSTRUCTION MANUAL
W/ PARTS IDENTIFICATION

2565-958_REV_B 08/2024



YETTER MANUFACTURING CO.
FOUNDED 1930

Colchester, IL 62326-0358
Toll free: 800/447-5777
309/776-3222 (Fax)

Website: www.yetterco.com
E-mail: info@yetterco.com

YETTER

FOREWORD

You've just joined an exclusive but rapidly growing club.
For our part, we want to welcome you to the group and thank you for buying a Yetter product.

We hope your new Yetter products will help you achieve both goals-increase your productivity and increase your efficiency so that you may generate more profit.

This operator's manual has been designed into four major sections: Foreword, Safety Precautions, Installation Instructions and Parts Breakdown.

This **SAFETY ALERT SYMBOL** indicates important safety messages in the manual. When you see this symbol, be alert to the possibility of **PERSONAL INJURY** and carefully read the message that follows.

 **DANGER:** Indicates an imminently hazardous situation which, if not avoided "will" result in death or serious injury. This signal word is to be limited to the most extreme situations

 **WARNING:** Indicates a potentially hazardous situation which, if not avoided, "could" result in death or serious injury.

 **CAUTION:** Indicates a potentially hazardous situation, which if not avoided, "may" result in minor or moderate injury. It may also be used to alert against unsafe practices.

 **NOTICE:** Indicates information considered important, but not hazard related (e.g., messages relating to property damage).

It is the responsibility of the user to read the operator's manual and comply with the safe and correct operating procedure and to lubricate and maintain the product according to the maintenance schedule in the operator's manual.

The user is responsible for inspecting his machine and for having parts repaired or replaced when continued use of the product would cause damage or excessive wear to the other parts.

It is the user's responsibility to deliver his machine to the Yetter dealer who sold him the product for service or replacement of defective parts, which are covered by the warranty policy.

If you are unable to understand or follow the instructions provided in this publication, consult your local Yetter dealer or contact:

YETTER MANUFACTURING CO.

309/776-4111

800/447-5777

309/776-3222 (FAX)

Website: www.yetterco.com

E-mail: info@yetterco.com

WARRANTY POLICY

Yetter Manufacturing warrants all products manufactured and sold by it against defects in material. This warranty being expressly limited to replacement at the factory of such parts or products as will appear to be defective after inspection. This warranty does not obligate the Company to bear cost of labor in replacement of parts. It is the policy of the company to make improvements without incurring obligations to add them to any unit already sold. No warranty is made or authorized to be made, other than herein set forth. This warranty is in effect for one year after purchase.

Dealer: _____

Yetter Manufacturing warrants its own products only and cannot be responsible for damage to equipment on which it is mounted.



SAFETY PRECAUTIONS



A brief description of signal words that may be used in this manual:

DANGER: Indicates an imminently hazardous situation which, if not avoided “will” result in death or serious injury. This signal word is to be limited to the most extreme situations.

WARNING: Indicates a potentially hazardous situation which, if not avoided, “could” result in death or serious injury.

CAUTION: Indicates a potentially hazardous situation, which if not avoided, “may” result in minor or moderate injury. It may also be used to alert against unsafe practices.

NOTICE: Indicates information considered important, but not hazard related (e.g., messages relating to property damage).

Consult your implement and tractor operator’s manual for correct and safe operating practices. Be aware of towed implement width and allow safe clearance.

Safety decals are placed on the implement to alert the operator and others to the risk of personal injury or unsafe operation during normal operations and servicing.

1. The safety decals must be kept clean and in good condition to ensure that they are legible.
2. Safety decals must be replaced if they are missing or illegible.
3. When components are replaced during repair or servicing, check that the new components include the necessary safety signs.
4. Replacement safety decals may be obtained from your local dealer.



WARNING

Read these instructions carefully to acquaint yourself with the Equipment. Working with unfamiliar equipment can lead to accidents.

Never park the equipment on a steep incline or leave the equipment running unattended.

Never clean, lubricate or adjust a machine that is in motion.

Always check that straps are secure.

Make sure latches are in pinned position when moving equipment.

Do not allow children to operate this equipment.

Do not allow riders on the equipment, trailer and/or pick-up.

Use speed and caution dictated by the terrain being traversed. Do not operate on any slope steep enough to cause tipping or loss of control.

Read and understand the operator’s manual and require all other persons who will operate the equipment to do the same.

If operating on public roadways, where legal, be certain all lighting is operating properly and observe all traffic laws.

Beware of increased stopping distances and control effort when operating with implements attached.

Be familiar with all controls and be prepared to stop equipment quickly in an emergency.

FAILURE TO HEED MAY RESULT IN PERSONAL INJURY OR DEATH.

TABLE OF CONTENTS







FOREWORD.....	2
SAFETY.....	2-3
TABLE OF CONTENTS/BOLT TORQUE.....	4
GENERAL INFORMATION.....	5
CM ASSEMBLY INSTRUCTIONS.....	6 – 10
FM ASSEMBLY INSTRUCTIONS.....	11 - 12
OPERATION.....	13 - 14
MAINTENANCE.....	XX - XX
PARTS IDENTIFICATION.....	XX - XX
TROUBLESHOOTING.....	20

BOLT TORQUE

READ THESE INSTRUCTIONS FIRST:

1. Improperly tightened bolts will result in damage, breakage, expense, and down time.
2. Always replace bolts with the specified grade and type.
3. Torque properly before first use of the machine and every 2-4 hours of use until you are sure bolts are staying tight.
4. The chart below is a guide for proper torque. Use it unless a specified torque is called out elsewhere in the manual.
5. Torque is the force you apply to the wrench handle or the cheater bar, times the length of the handle or bar.
6. Use a torque wrench whenever possible.

The following table shows torque in ft. lbs.

BOLT DIA. AND THREADS PER INCH	 GRADE 2	 OR  GRADE 5 A-325	 GRADE 8
1/4	6	10	14
5/16	12	20	30
3/8 - 16	25	35	50
7/16 - 14	35	55	80
1/2 - 13	55	85	125
9/16 - 12	75	125	175
5/8 - 11	105	170	235
3/4 - 10	185	305	425
7/8 - 9	170	445	690
1-8	260	670	1030
1 1/8 - 7	365	900	1460
1 1/4 - 7	515	1275	2060
1 3/8 - 6	675	1675	2700
1 1/2 - 6	900	2150	3500
1 3/4 - 5	1410	3500	5600

GENERAL INFORMATION

**NOTICE: Examine all equipment carefully for damage or shortages.
PART NUMBERS AND DESCRIPTIONS**

PART NUMBER	DESCRIPTION
9010-001	TrackTill FM (frame mount) 30 Kit (Pneumatic)
9010-003	TrackTill CM (center mount) 30 Kit (Hydraulic)
9010-004	TrackTill FM30 Kit (Hydraulic)
9010-010	CM Frame Kit
9010-015	TrackTill CM Hitch Kit
9010-020	Pneumatic Kit
9010-021	Hydraulic Kit
9010-025	Cab Control Lift Lock Kit
9010-030	Hydraulic Retro-Fit Kit

CM TRACK TILL ASSEMBLY INSTRUCTIONS

 **WARNING: NEVER WORK UNDER THE EQUIPMENT WHILE IN A RAISED POSITION WITHOUT USING SAFETY LOCK UPS. FAILURE TO DO SO MAY LEAD TO PERSONAL INJURY OR DEATH.**

 **NOTICE: WHEN INSTALLING & ROUTING EACH HYDRAULIC HOSE, USE AN INDICATOR TO DISTINGUISH BETWEEN PRESSURE & RETURN HYDRAULIC HOSES. E.G. - COLORED ZIP TIES, PAINT MARKER, ETC.**

 **NOTICE: IF PLANTER IS EQUIPPED WITH TRACKS, THE TOOL BAR SADDLE WILL NEED MODIFIED TO SET THE UNITS BACK APPROXIMATELY 7 – 8 INCHES.**

Tools Required: Forklift/floor jack, impact, 1 1/8" socket, 1 1/8" wrench, 2 crescent wrenches.

STEP 1: At the rear of the center rear of the planter, place the 2) 9010-212 Top Clamp W.A. on top of the tongue spaced apart roughly 14 inches. The U-bolt holding the ladder down will need removed.

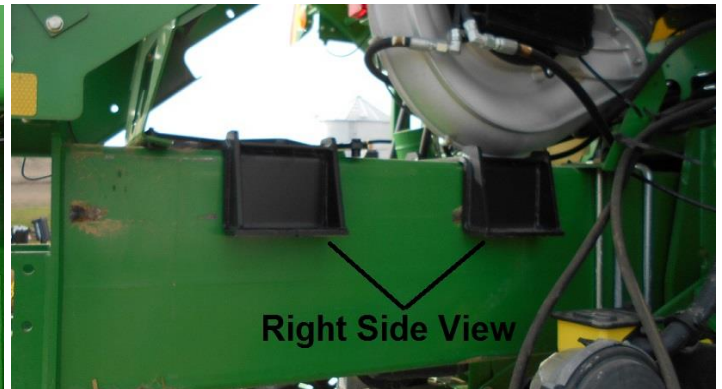
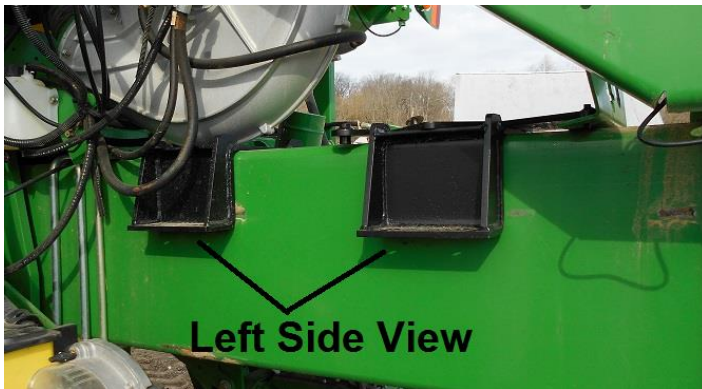

STEP 2: Set the 9010-217 Toolbar Saddle W.A. in place on the bottom side of the tongue aligning the holes with the top clamps from in step 1. Install a total of 8) 3/4" bolts, 16 3/4" flat washers, & 8) 3/4" lock nuts & tighten. Length of bolts used, 3/4" X 7" or 3/4" X 11", will be dependent on the tongue size.



STEP 3: Insert the lock pin, 9010-374 5/8" X 10 1/2" (JD planters), 9010-375 1" X 10 1/2", (CHN planters), & 9010-376 1 1/4" X 13 7/16" (Kinze planters), through the frame anchor slotted holes. Install washers & roll pins on each end.



CM TRACK TILL ASSEMBLY INSTRUCTIONS CONT'D

STEP 4: Install the Step Bracket Clamp W.A. to hold the ladder bracket in place.

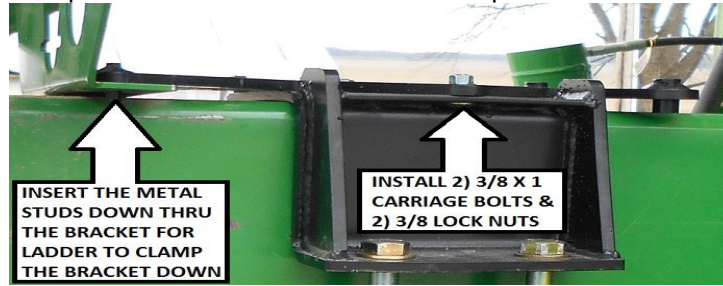

STEP 5: Insert the 5" & 7" rubber dampeners on the Frame Clamp. Install the 9010-366 CM Toolbar on the Frame Clamp W.A. on the 9010-217 Toolbar Saddle W.A. using the 2) 9010-367 clamps, 12) 3/4" X 3 1/2" bolts, 12) 3/4" flat washers, 12) 3/4" whizlok nuts, & 12) 9010-373 spacers. Before tightening the hardware, center the toolbar by marking the center and aligning that mark with the center distance between the saddles.

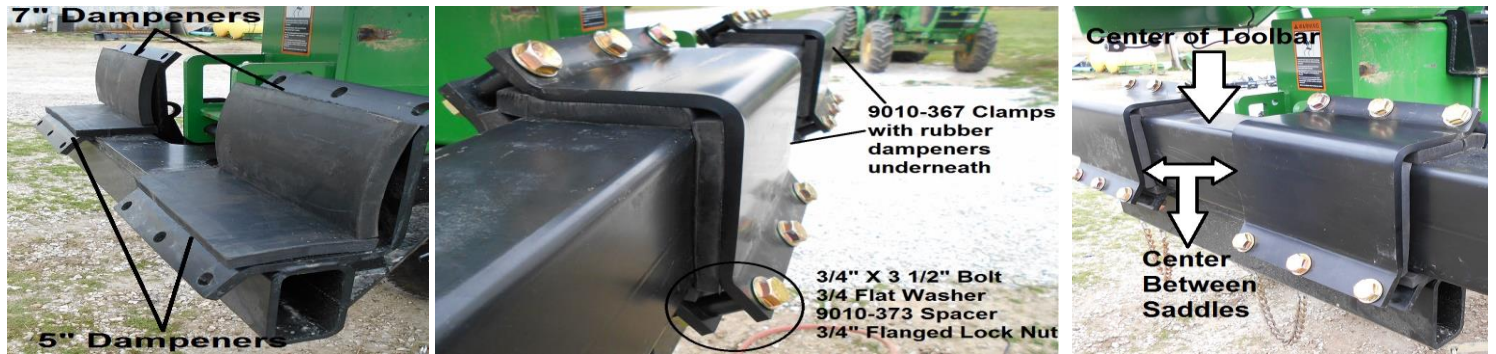

STEP 6: Mount the Track Till units to the 9010-366 CM Toolbar directly behind each center lift wheel. Each unit mounts using 2) 2570-477 3/4 X 7 X 7 U-Bolts, 4) 2525-501 3/4 Lock Washers, & 4) 2520-506 3/4 Hex Nuts. The Track Till tine assemblies behind the left 2 planter lift wheels should be 9010-119 V1 models & have tines in L – L – R order. The Track Till tine assemblies behind the right 2 planter lift wheels should be 9010-120 V2 models & have tines in L – R – R order. Each tine is stamped L or R as well as an indicator arrow.

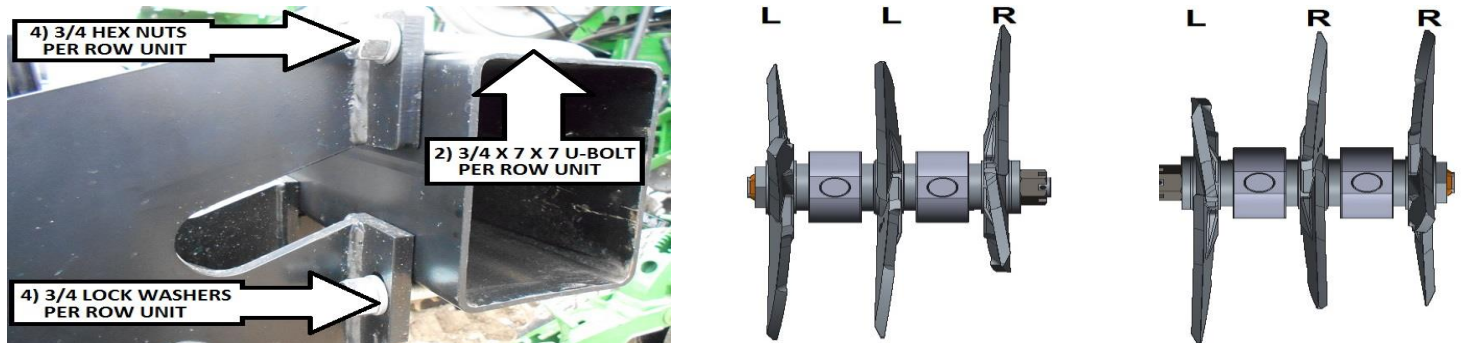

STEP 7: Install 1) 2515-383 3/8 X 35" hydraulic hose on each end, pressure & return, of each the 4 hydraulic cylinders. Tee the pressure hydraulic hoses together on the left 2 units using 1) 2515-326 -6 / -6 / -6 JIC Tee. Tee the return hydraulic hoses together on the left 2 units using 1) 2515-326 Tee. Tee the pressure hydraulic hoses together on the right 2 units using 1) 2515-326 tee. Tee the return hydraulic hoses together on the right 2 units using 1) 2515-326.

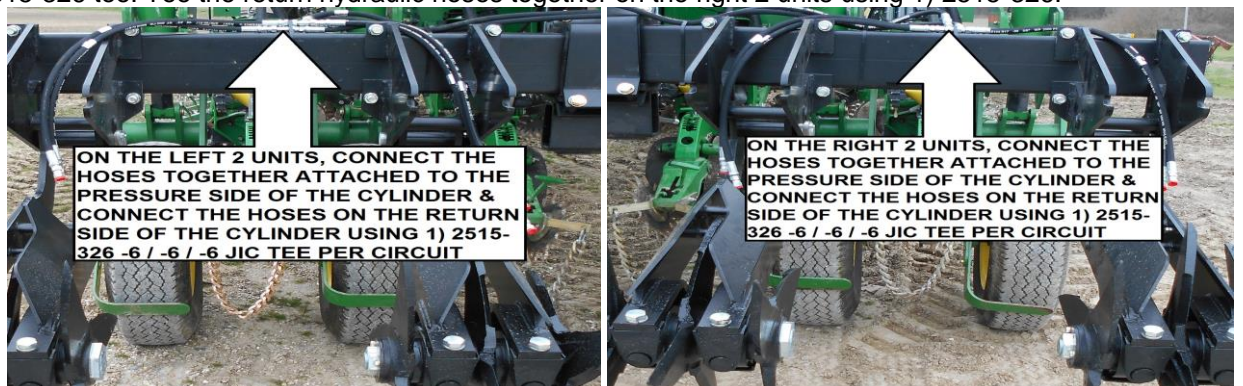
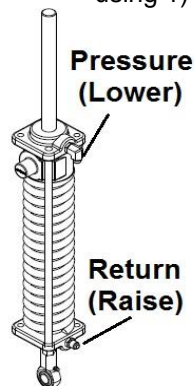

CM TRACK TILL ASSEMBLY INSTRUCTIONS CONT'D

STEP 8: On the left 2 units, install 1) 2515-386 3/8 X 50" hydraulic hose in the Tee for the pressure circuit & 1) 2515-386 in the Tee for the return circuit. On the right 2 units, install 1) 2515-386 in the Tee for the pressure circuit & 1) 2515-386 for the return circuit. Route the end of the hoses to the center of the 9010-366 CM Toolbar.

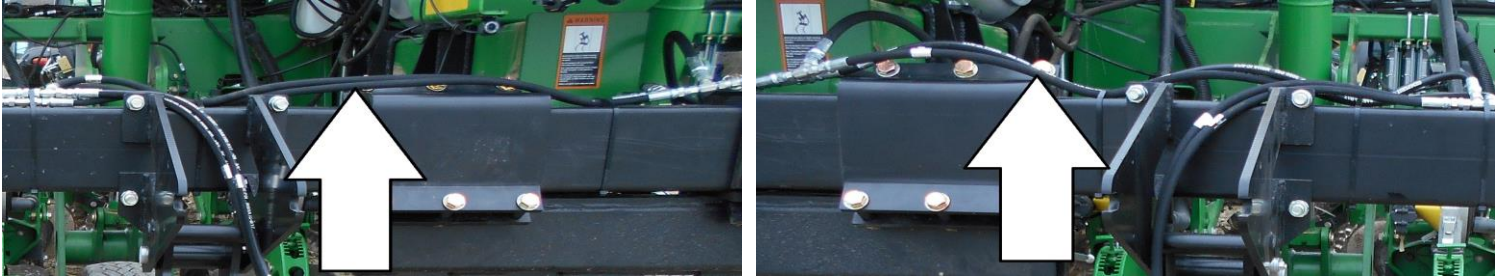

STEP 9: Install 1) 2515-435 -6 / -6 / -8 Tee to connect the pressure hoses from step 7. Install 1) 2515-435 Tee to connect the return hoses from step 7.



STEP 10: Install the 9010-116 hydraulic pressure valve assembly on the left side of the 9010-217 toolbar saddle using 2) 2502-216 5/16 X 3 GR 5 bolts & 2) 2520-205 5/16 lock nuts.



STEP 11: Install 1) 2515-613 1/2" X 32" with -8 female JIC ends on the 2515-435 Tee connecting the pressure circuit from step 8. Route the other end to the 9010-116 hydraulic pressure valve assembly. Install 1) 2515-613 on the 2515-435 Tee connecting the return circuit from step 8. Route the other end to the 9010-116.

STEP 12: Install 1) 2515-430 JIC -8 Run Tee in the planter frame lift circuit on JD planters, blower motor pressure circuit on all other planters. Install 1) 2515-430 in the planter frame lower circuit on JD planters, blower motor return circuit on all other planters. On each Tee, install 1) 2515-612 1/2" X 150" hydraulic hose with -8 female ends. Route to the 9010-116 hydraulic pressure valve.

STEP 13: On the 2515-612 hydraulic hose installed on the planter frame lower circuit or the blower motor pressure circuit, install the open end of that hose onto the fitting labeled A in the picture below. On the 2515-613 hydraulic hose that is attached into the pressure side of the 9010-109 hydraulic cylinders, install the open end of that hose onto the fitting labeled B in the picture below. On the 2515-613 hydraulic hose that is attached into the return side of the 9010-109 hydraulic cylinders, install the open end of that hose onto the fitting labeled C. On the 2515-612 hydraulic hose installed on the planter frame pressure circuit or the blower motor return circuit, install the open end of that hose onto the fitting labeled D. The valve handle labeled E allows you to lock the Track Till units in the raised position & the pressure regulator labeled F allows you to adjust the downforce on the Track Till units.

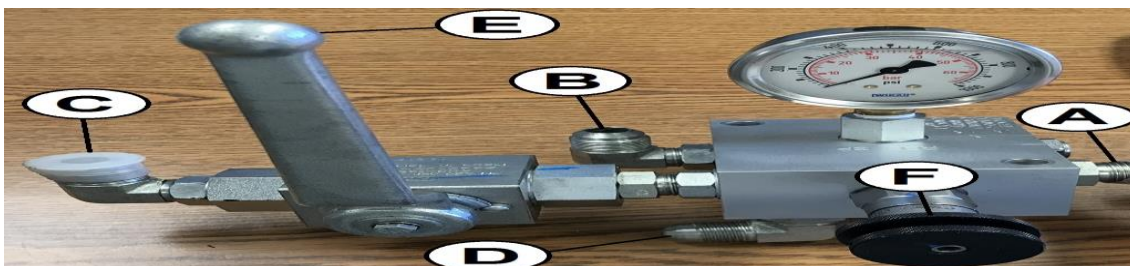

FM TRACK TILL ASSEMBLY INSTRUCTIONS

NOTE: ON HYDRAULIC DRIVE DB PLANTERS, YOU WILL NEED TO REPOSITION THE HYDRAULIC MOTOR AND ADD THE PROVIDED CHAIN LINKS TO ALLOW THE TRACK TILL UNITS TO FIT PROPERLY & BE CENTERED DIRECTLY BEHIND THE CARRYING WHEELS.

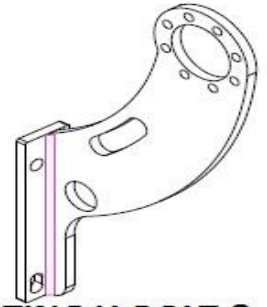

USE EXISTING U-BOLT & HARDWARE TO MOUNT TO TOOLBAR & TO MOUNT THE MOTOR

STEP 1: Place 2) 2570-474 $\frac{3}{4}$ X 7 X 7 U-bolts on the toolbar behind the 4 center lift wheels. Measure between the rows where the Track Till will be mounted & mark the center.

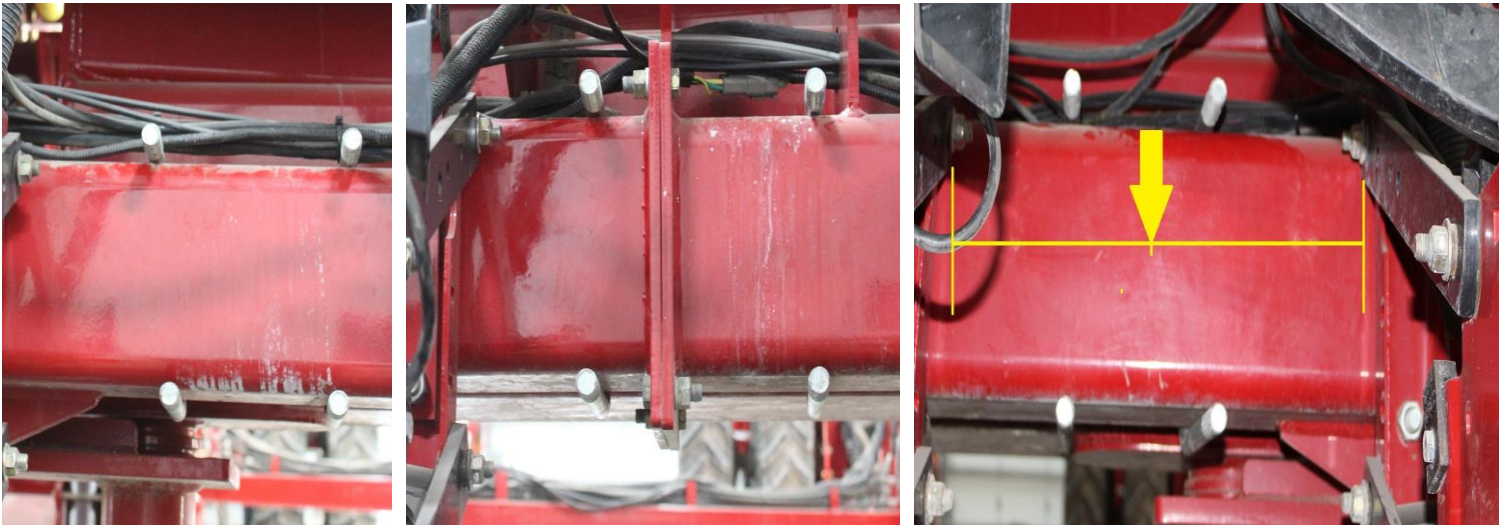

STEP 2: Install the units on the frame, centered between the rows & over the lift wheel track. Using an overhead hoist or forklift is the easiest way to set them in place to mount the U-bolts. Insert the U-bolts through the mounting holes, install the 2525-501 $\frac{3}{4}$ lock washer & 2520-506 $\frac{3}{4}$ hex nut, and tighten hardware to torque specification.

NOTE: Some planter toolbars will have obstacles that may keep you from centering the Track Till units over the lift wheel such as flanges for bolt together toolbars, mounting tabs for the hex drive shaft, vacuum hoses, etc. In some instances, a setback bracket may need built.

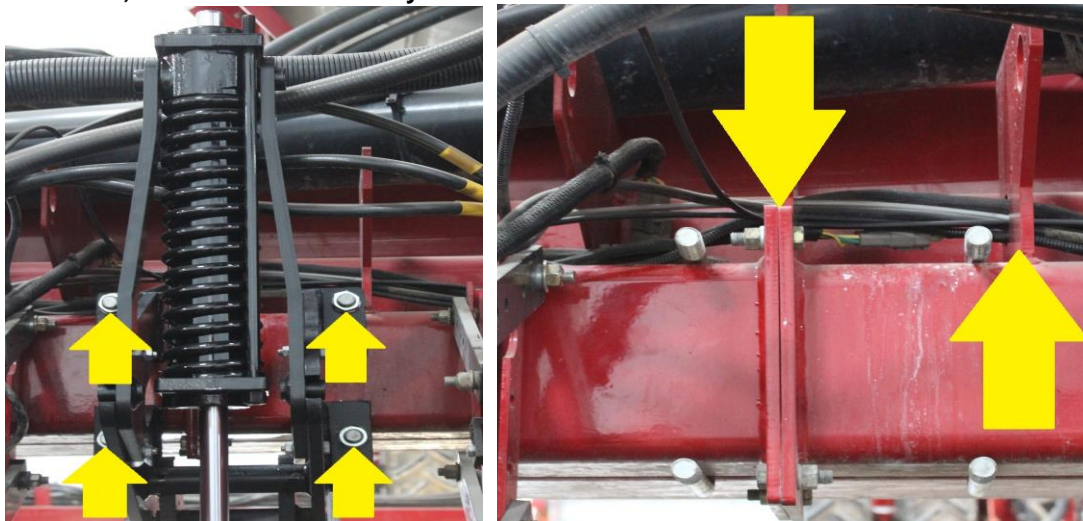

FM TRACK TILL ASSEMBLY INSTRUCTIONS

STEP 3: Install 1) 2515-383 3/8 X 35" hydraulic hose on each end, pressure & return, of each the 4 hydraulic cylinders (total of 8 hoses) as indicated by the 4 yellow arrows. Tee the pressure hydraulic hoses together on the left 2 units using 1) 2515-326 -6 / -6 / -6 JIC Tee. Tee the return hydraulic hoses together on the left 2 units using 1) 2515-326 tee. Tee the pressure hydraulic hoses together on the right 2 units using 1) 2515-326 tee. Tee the return hydraulic hoses together on the right 2 units using 1) 2515-326.

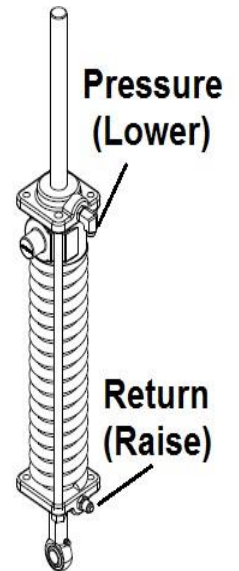
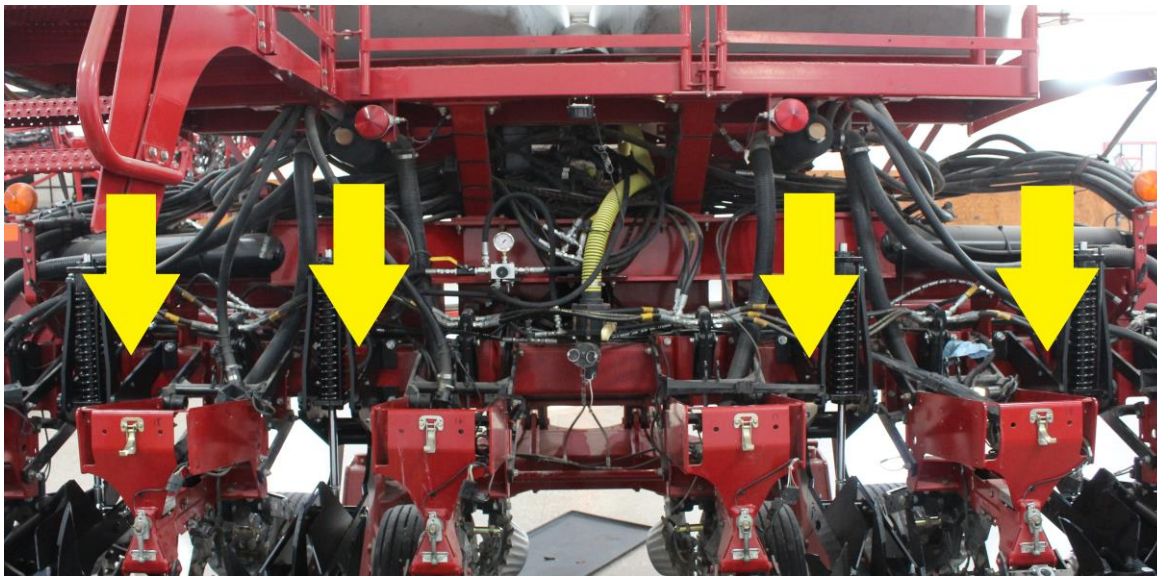

STEP 4: On the left 2 units, install 1) 2515-386 3/8 X 50" hydraulic hose in the Tee for the pressure circuit & 1) 2515-386 in the tee for the return circuit. On the right 2 units, install 1) 2515-386 in the Tee for the pressure circuit & 1) 2515-386 for the return circuit. Route the end of the hoses to the center of the planter toolbar (as indicated by the yellow arrow).

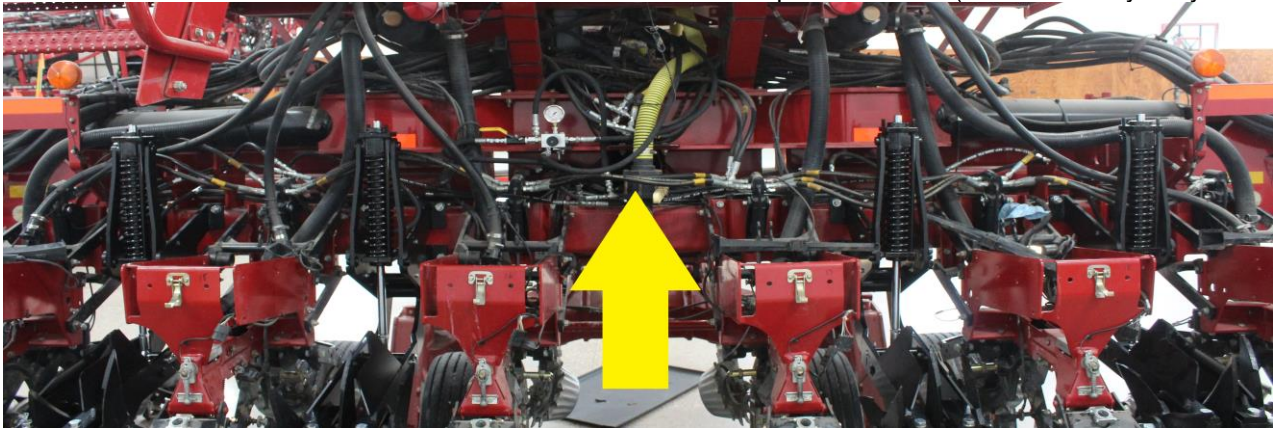

STEP 5: Install the 9010-116 hydraulic valve block on the planter in a location that is easily accessible. Use the 9010-410 valve bracket & 2570-765 5/8 X 6 X 5 1/2 U-bolt. If the toolbar doesn't allow this method to work, make modifications to the bracket to mount the bracket on the planter elsewhere. Align the holes on the valve block assembly & the valve bracket & use 5/16 hardware to attach the valve block and valve bracket together, fasten the hardware.

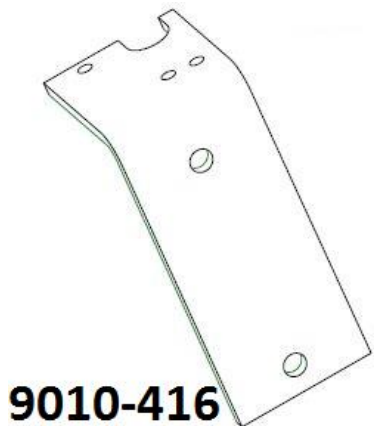

FM TRACK TILL ASSEMBLY INSTRUCTIONS

STEP 6: Install 1) 2515-435 -6 / -6 / -8 Tee to connect the pressure hoses from step 4. Install 1) 2515-613 ½" X 32" hydraulic hose on the 2515-435 tee connecting the pressure circuit. Route the other end to the 9010-116 & install to the hydraulic elbow fitting labeled B in the diagram below. Install 1) 2515-435 tee to connect the return hoses from step 4. Install 1) 2515-613 ½" X 32" hydraulic hose on the 2515-435 tee connecting the return circuit. Route the other end to the 9010-116 & install to the hydraulic elbow fitting labeled C in the diagram below.

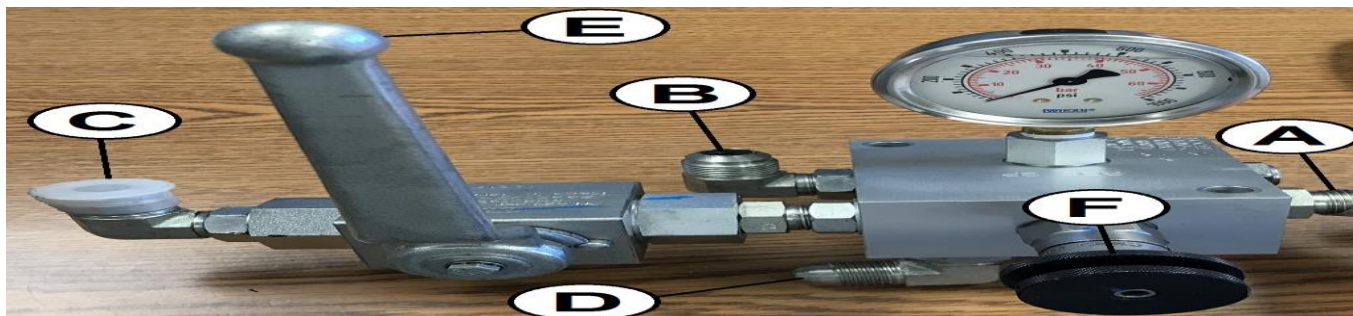

STEP 7: Plumb the 2515-612 ½" X 150" hydraulic hoses into a planter circuit chosen to operate the track till units. The circuit must have constant flow while the planter is in planting position. On JD planters, the lift/lower/blower motor circuit is best. On Agco, CNH, Kinze, etc. planters, the blower motor circuit is best. Make sure there is enough flow in the chosen circuit before plumbing begins. Use the hydraulic tees provided or, if necessary, source fittings locally.

STEP 8: Attach the 2515-612 hydraulic hose that is plumbed into the planter circuit with constant flow into the 9010-116 hydraulic block to the fitting labeled A in the diagram above. Attach the 2515-612 hydraulic hose that is plumbed into the planter circuit that isn't receiving constant into the 9010-116 hydraulic block to the fitting labeled D in the diagram above.

OPERATION

Raise/Lower

- On JD planters, when the hydraulics are plumbed correctly, when the planter is raised, the track till units should raise. When the planter is lowered and hydraulics locked in constant, the track till units should lower & have down pressure until the planter is raised or the constant flow is disengaged.
- On Agco, CNH, Kinze, etc. planters, when the hydraulics are plumbed correctly, the track till units will have constant down pressure whenever the blower motor is operating. To raise the track till units, switch the flow on the SCV to the return side and hold until the track till units are raised.
- An optional Cab Control Lift Lock Kit may be purchased to keep the Track Till units in the raised position when the operator does not want them engaged

Hydraulic Valve Block

- Use the adjustment knob (labeled F in diagram above) to change the pressure to the track till hydraulic cylinders (0 – 1300psi)
- Use the valve handle (labeled E in the diagram above) to lock the track till units into the raised position.

Field Operation

- Tines should penetrate the compacted soil area 5 – 7 inches deep
- If tines happen to cover the planted rows with soil or residue, rearrange the tine configuration so the outside tines are convex instead of concave

Storage

- Always relieve the track till cylinders of hydraulic pressure before putting the machine away for storage.

Tine Replacement

- Replace track till tines when penetration becomes an issue or when the each tine length measured from the center of the hub is LESS than 8 inches.

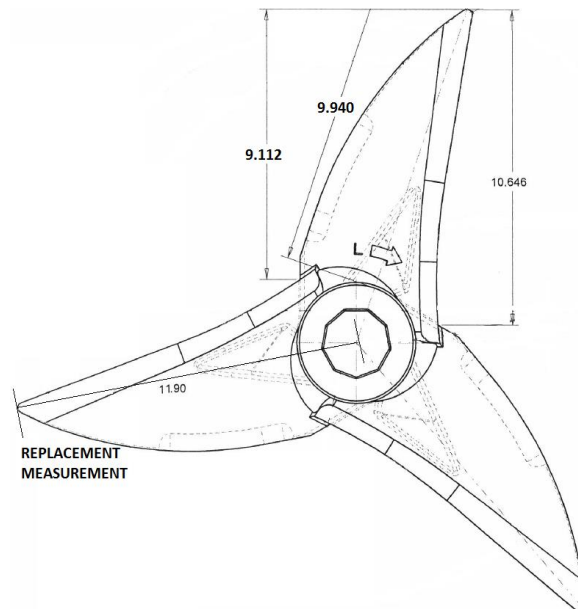

MAINTENANCE

BEARING ASSEMBLY AND LUBRICATION

Practice Safety

Understand and practice safe service procedures before doing work. Follow ALL the operating, maintenance and safety information in the equipment operator manual. Clear the area of bystanders, especially small children, when performing any maintenance or adjustments. Keep work area clean and dry. Use adequate lighting for the job. Use only tools, jacks and hoists of sufficient capacity for the job.

Never lubricate, service, or adjust machine while it is moving. Keep hands, feet, and clothing from power-driven moving and rotating parts. Disengage all power and operate controls to relieve pressure. Lower equipment to the ground and stop the engine. Remove the key. Wait for all moving parts to stop before servicing, adjusting, repairing or unplugging.

Securely support any machine elements with blocks or safety stands that must be raised for service work.

Keep all parts in good condition and properly installed. Fix damaged equipment immediately. Replace worn or broken parts.

Remove any buildup of grease, oil, or debris.

Make sure all guards are in place and properly secured when maintenance work is completed.

Lubrication



CAUTION: To help prevent serious injury or death to you or others caused by unexpected movement, service machine on a level surface. Lower machine to ground or sufficiently lock or block raised machine before servicing. If machine is connected to tractor, engage parking brake and place transmission in "PARK", shut off engine and remove key. If machine is detached from tractor, block wheels and use shop stands to prevent movement.

Lubrication



CAUTION: Do not clean, lubricate, or adjust machine while in motion.

Use grease based on NLGI consistency numbers and the expected air temperature range during the service interval.

Yetter uses a high temperature, polyurea grease when assembling product at the factory. **DO NOT** mix different types of grease. Doing so will cause the mixture to harden & will not release any oil or the mixture will soften releasing all the oil. In either case, there is effectively no lubrication.

Other greases may be used if they meet the following **NLGI Performance Classification: GC-LB**

NOTICE: Some types of grease thickener are not compatible with others. Consult your grease supplier before mixing different types of grease.

Alternative Lubricants

Conditions in certain geographical areas may require special lubricants and lubrication practices which do not appear in the operator's manual. If there are any questions, consult Yetter Manufacturing Co. to obtain latest information & recommendation.

Storing Lubricants

Your machine can operate at top efficiency only if clean lubricants are used. Use clean containers to handle all lubricants. Store them in an area protected from dust, moisture and other contaminants.



Lubrication Symbols

Lubricate with grease at hourly interval indicated on symbol.

Lubrication Intervals

NOTICE: The recommended service intervals are based on normal conditions; severe or unusual conditions may require more frequent lubrication.

Perform each lubrication and service procedure at the beginning and end of each season.

The bearings on the Track Till tine assemblies are sealed and no greasing is required.

Inspect the hydraulic hoses/connections/valve assembly for leaks daily or when filling the planter with seed.

Storing the Equipment

Store the machine in an area away from human activity. Store machine in RAISED position. Install service locks on all wheel cylinders.

At the end of the season, the machine should be thoroughly inspected and prepared for storage. Repair or replace any worn or damaged components to prevent down time at the start of the next season. Store machine under cover with all parts in operating condition.

- Clean machine thoroughly to remove all dirt, debris, fertilizer spatter, and crop residue, which would hold moisture and cause rusting.
- Inspect machine for worn or broken parts. See your Yetter Farm Equipment dealer during the off-season so that parts or service can be acquired when machine is not needed in the field.
- Lubricate bearings as outlined in the Lubrication section
- Paint all parts which are chipped or worn and require repainting.
- Store machine in a clean, dry place with the planting unit out of the sun.
- If the machine cannot be stored inside, cover with a waterproof tarpaulin and tie securely in place.
- Do not allow children to play on or around the machine

9010-100 PARTS IDENTIFICATION

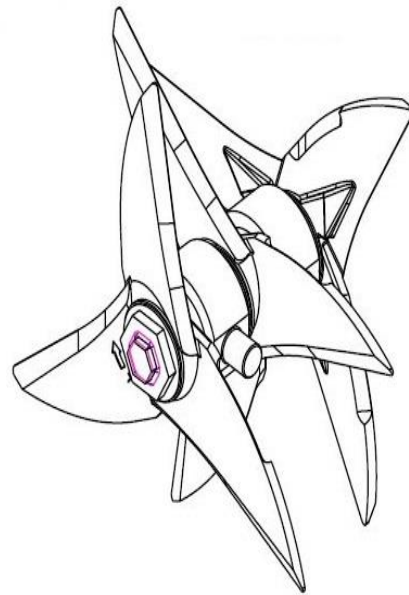
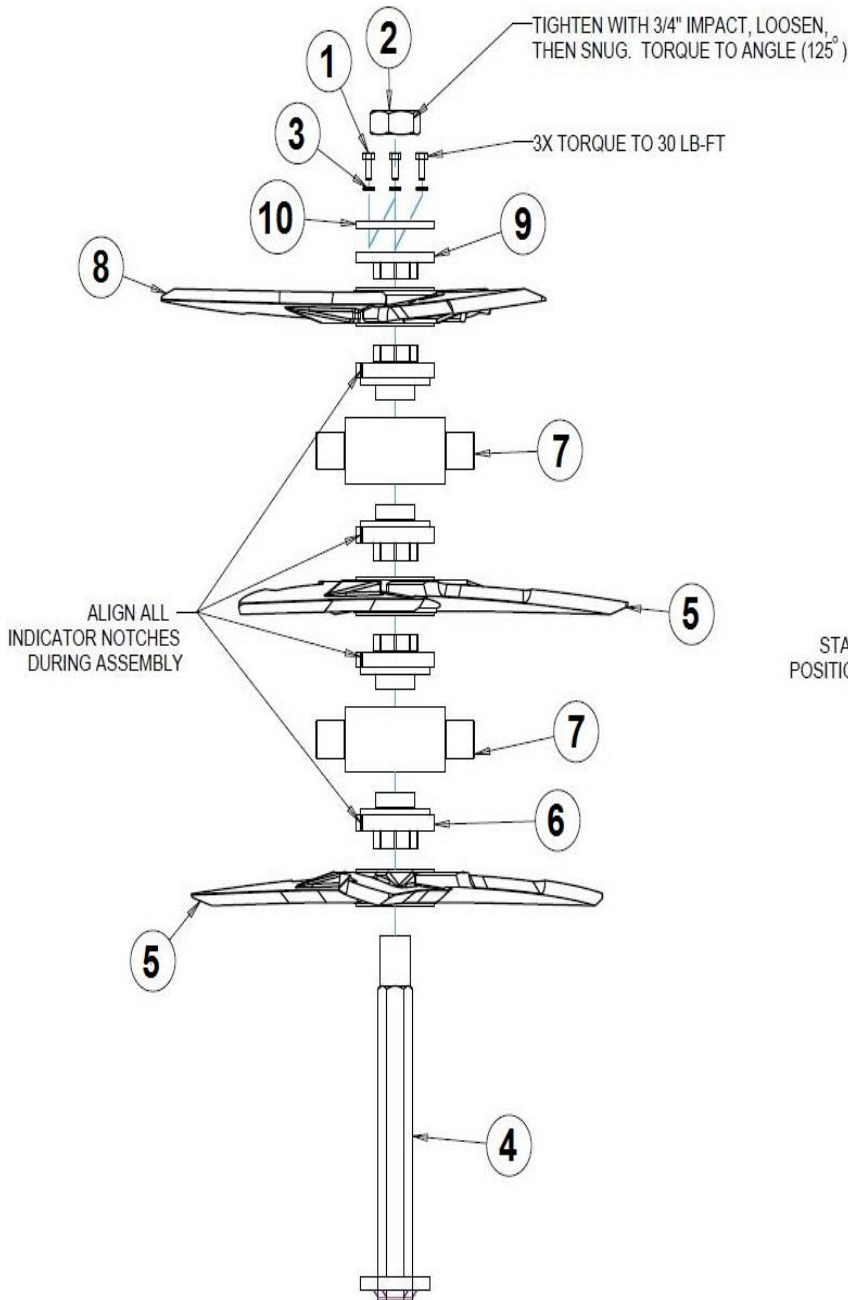

STAGGER TINES BY ROTATING ONE POSITION AHEAD OF THE PRIOR TINE

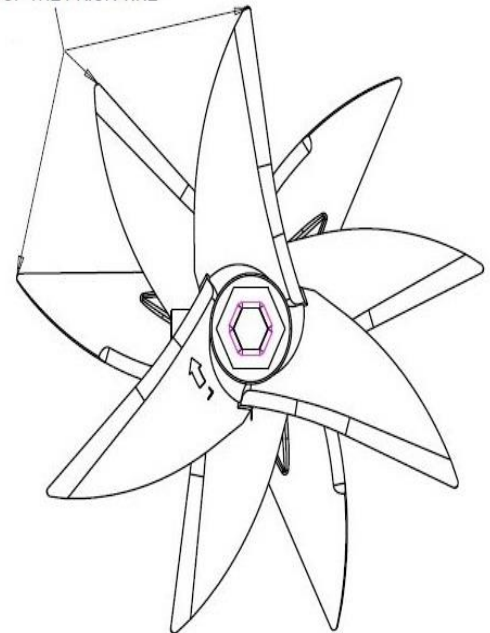

ITEM	PART NUMBER	DESCRIPTION	QUANTITY
1	2502-199	5/16 - 18 X 3/4 HHCS	3
2	2520-583	1 1/2 - 12 UNF HEX JAM NUT GR 8 ZP	1
3	2525-201	5/16 MEDIUM LOCK WASHER ZP	3
4	9010-206	HEX AXLE W.A.	1
5	9010-320	TINE, LH	2
6	9010-321	TINE SPACER	4
7	9010-322	BEARING ASSEMBLY, W211K58-TTU	2
8	9010-323	TINE, RH	1
9	9010-324	END WASHER	1
10	9010-325	LOCKING RING	1

MANUFACTURED 11/15 – 09/16

9010-101 PARTS IDENTIFICATION

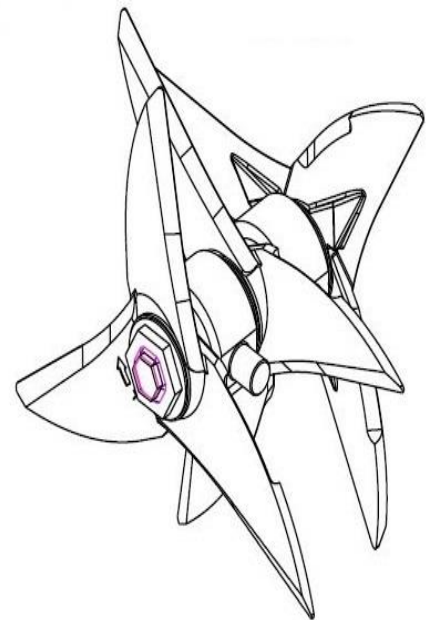
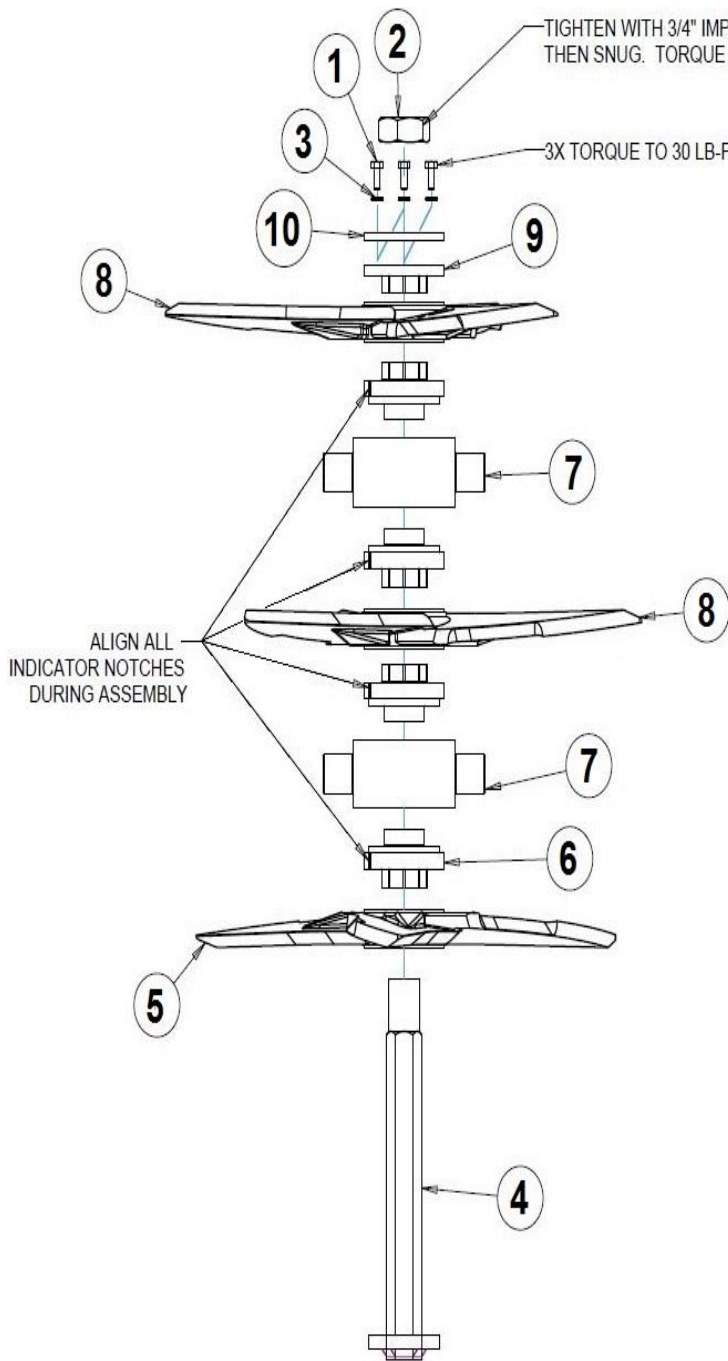

STAGGER TINES BY ROTATING ONE POSITION AHEAD OF THE PRIOR TINE

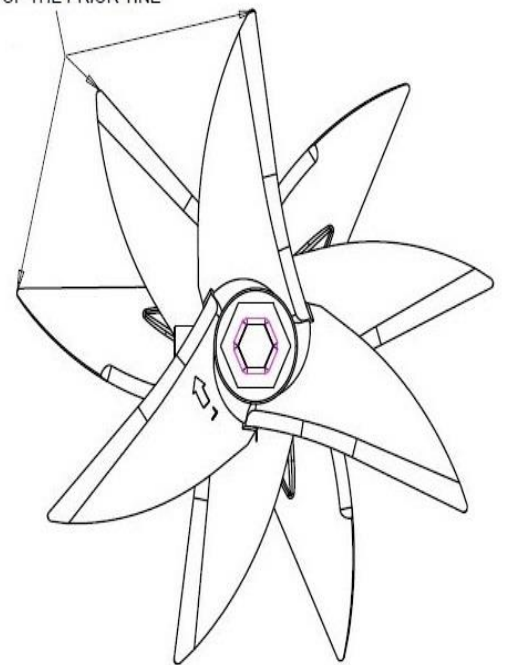

ITEM	PART NUMBER	DESCRIPTION	QUANTITY
1	2502-199	5/16 – 18 X 3/4 HHCS	3
2	2520-583	1 1/2 - 12 UNF HEX JAM NUT GR 8 ZP	1
3	2525-201	5/16 MEDIUM LOCK WASHER ZP	3
4	9010-206	HEX AXLE W.A.	1
5	9010-320	TINE, LH	1
6	9010-321	TINE SPACER	4
7	9010-322	BEARING ASSEMBLY, W211K58-TTU	2
8	9010-323	TINE, RH	2
9	9010-324	END WASHER	1
10	9010-325	LOCKING RING	1

MANUFACTURED 11/15 – 09/16

9010-102 & 9010-103 PARTS IDENTIFICATION

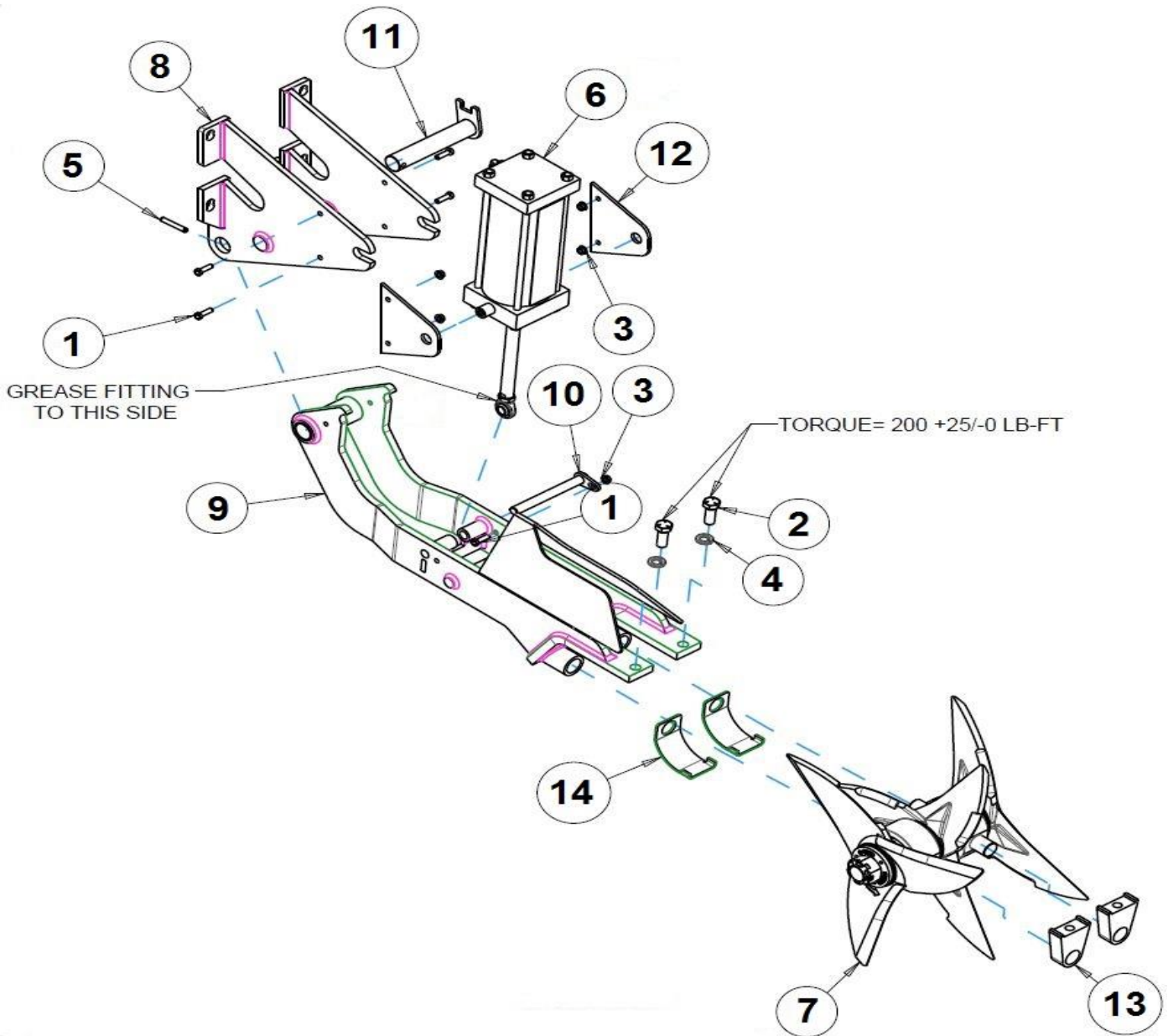

9010-102 SHOWN IN DIAGRAM

ITEM	PART NUMBER	DESCRIPTION	QUANTITY
1	2502-244	3/8 – 16 X 1 ¼ HHCS GR 5 ZP	5
2	2502-503	¾ - 10 X 2 HHCS GR 5 ZP	2
3	2520-258	3/8 – 16 HEX FLANGE LOCK NUT ZP	5
4	2525-501	¾ MEDIUM LOCK WASHER ZP	2
5	2530-208	3/8 X 2 ½ ROLL PIN ZP	1
6	9010-106	CYLINDER ASSEMBLY	1
7	9010-119 (9010-102)	TINE GANG ASSEMBLY, V1	1
	9010-120 (9010-103)	TINE GANG ASSEMBLY, V2	1
8	9010-202	FRAME MOUNT W.A.	1
9	9010-204	SWING ARM W.A.	1
10	9010-205	PIVOT PIN W.A.	1
11	9010-215	PIVOT PIN W.A.	1
12	9010-316	TRUNNION LOCK	2
13	9010-326	TRUNNION HANGER	2
14	9010-335	WEAR GUARD	2

9010-110 & 9010-111 PARTS IDENTIFICATION

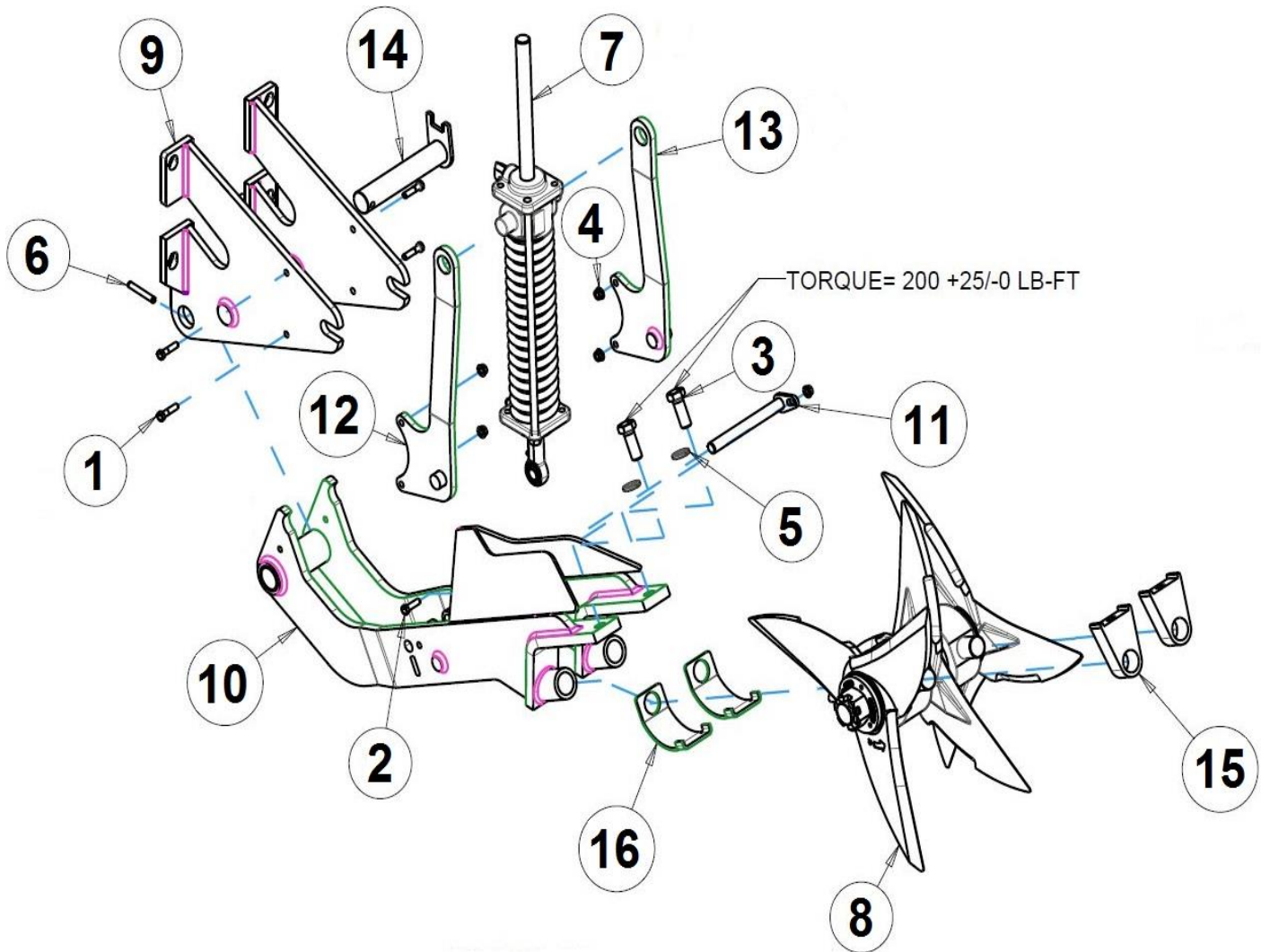

9010-110 SHOWN IN DIAGRAM

ITEM	PART NUMBER	DESCRIPTION	QUANTITY
1	2502-232	3/8 – 16 X 1 ½ HHCS GR 5 ZYD	4
2	2502-244	3/8 – 16 X 1 ¼ HHCS GR 5 ZP	1
3	2502-503	¾-10 X 2 HHCS GR 5 ZP	2
4	2520-258	3/8-16 HEX FLANGE LOCK NUT ZP	5
5	2525-501	¾ MEDIUM LOCK WASHER ZP	2
6	2530-208	3/8 X 2 ½ ROLL PIN ZP	1
7	9010-109	2X10 HYDRAULIC COIL OVER CYLINDER ASSY	1
8	9010-119 (9010-110)	TINE GANG ASSEMBLY, V1	1
	9010-120 (9010-111)	TINE GANG ASSEMBLY, V2	1
9	9010-202	FRAME MOUNT W.A.	1
10	9010-204	SWING ARM W.A.	1
11	9010-205	PIVOT PIN W.A.	1
12	9010-209	TRUNNION MOUNT W.A., LH	1
13	9010-210	TRUNNION MOUNT W.A.,RH	1
14	9010-215	PIVOT PIN W.A.	1
15	9010-326	TRUNNION HANGER	2
16	9010-335	WEAR GUARD	2

9010-119 PARTS IDENTIFICATION

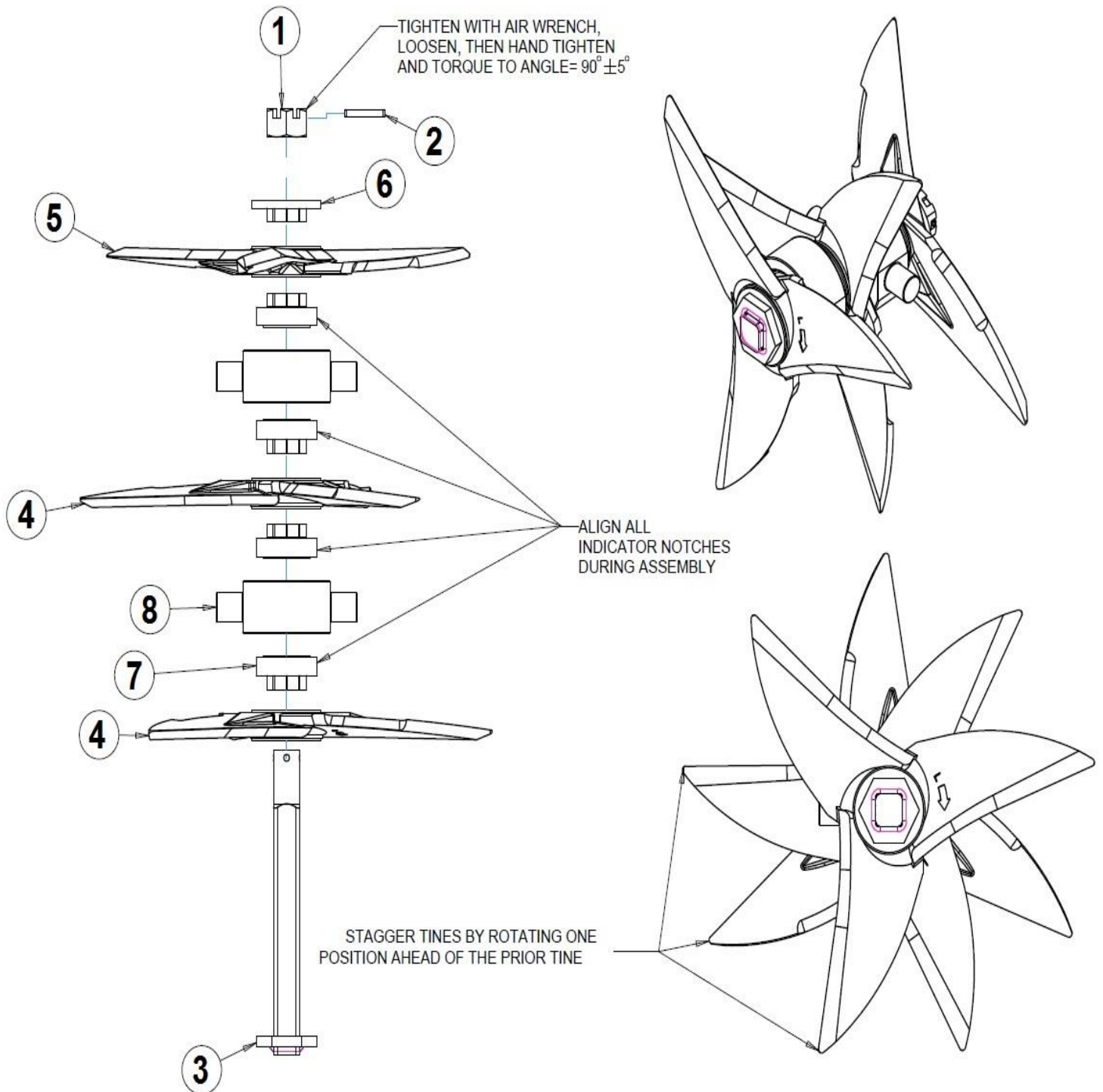

ITEM	PART NUMBER	DESCRIPTION	QUANTITY
1	2520-585	1-½ -12 SLOTTED NUT, GRADE B, ZP	1
2	2530-170	5/16 X 2-1/4 ROLL PIN, ZP	1
3	9010-218	SQUARE AXLE W.A.	1
4	9010-320	TINE, LH	2
5	9010-323	TINE, RH	1
6	9010-324	END WASHER	1
7	9010-398	TINE SPACER	4
8	9010-399	BEARING ASSEMBLY, W211K59-TTU	2

MANUFACTURED 9/16 – PRESENT

9010-120 PARTS IDENTIFICATION

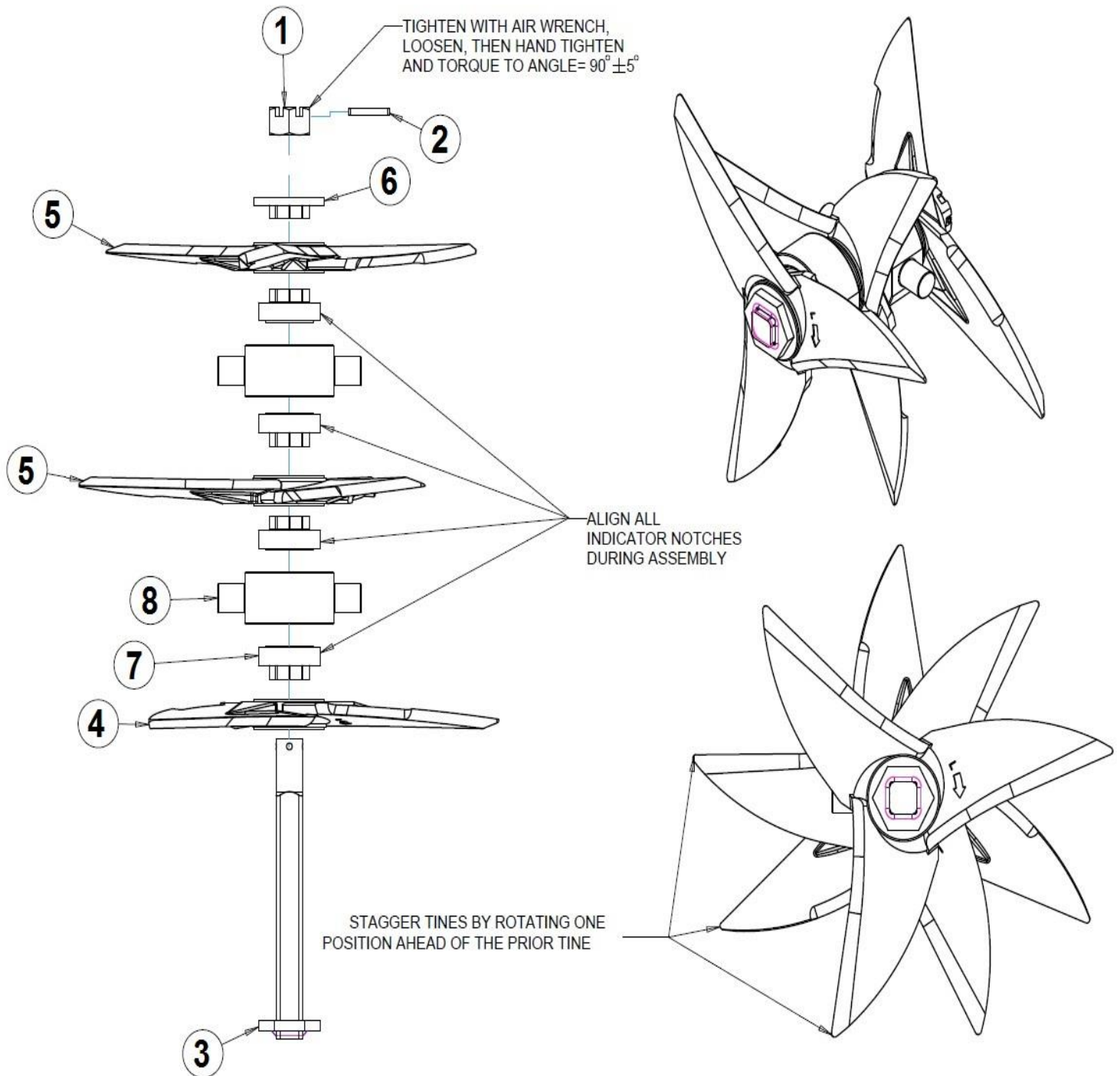

ITEM	PART NUMBER	DESCRIPTION	QUANTITY
1	2520-585	1-1/2 -12 SLOTTED NUT, GRADE B, ZP	1
2	2530-170	5/16 X 2-1/4 ROLL PIN, ZP	1
3	9010-218	SQUARE AXLE W.A.	1
4	9010-320	TINE, LH	1
5	9010-323	TINE, RH	2
6	9010-324	END WASHER	1
7	9010-398	TINE SPACER	4
8	9010-399	BEARING ASSEMBLY, W211K59-TTU	2

MANUFACTURED 9/16 – PRESENT

9010-108 PARTS IDENTIFICATION

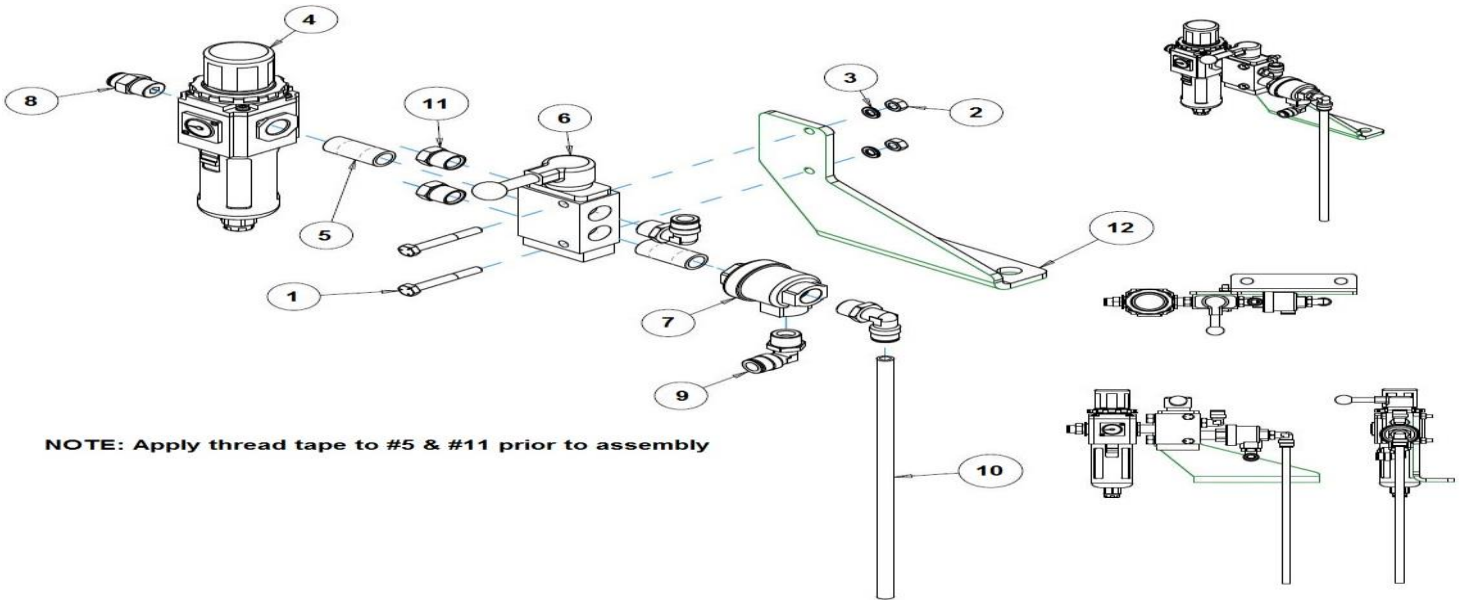

NOTE: Apply thread tape to #5 & #11 prior to assembly

ITEM	PART NUMBER	DESCRIPTION	QUANTITY
1	2502-102	¼ - 20 X 2 HHCS GR 5 ZP	2
2	2520-151	¼ - 20 HEX NUT ZP	2
3	2525-151	¼ MEDIUM LOCK WASHER ZP	2
4	9010-340	PNEUMATIC FILTER REGULATOR	1
5	9010-341	.375" PIPE NIPPLE, 1.5" LONG	2
6	9010-342	4 WAY VALVE	1
7	9010-343	QUICK EXHAUST VALVE	1
8	9010-344	3/8 MALE PUSH CONNECTOR, 3/8 NPTF	1
9	9010-345	3/8 MALE ELBOW SWIVEL, 3/8 NPTF	3
10	9010-346	3/8 TUBING, 12" LONG	1
11	9010-347	PNEUMATIC BREATHER	2
12	9010-348	VALVE MOUNT BRACKET	1

9010-116 PARTS IDENTIFICATION

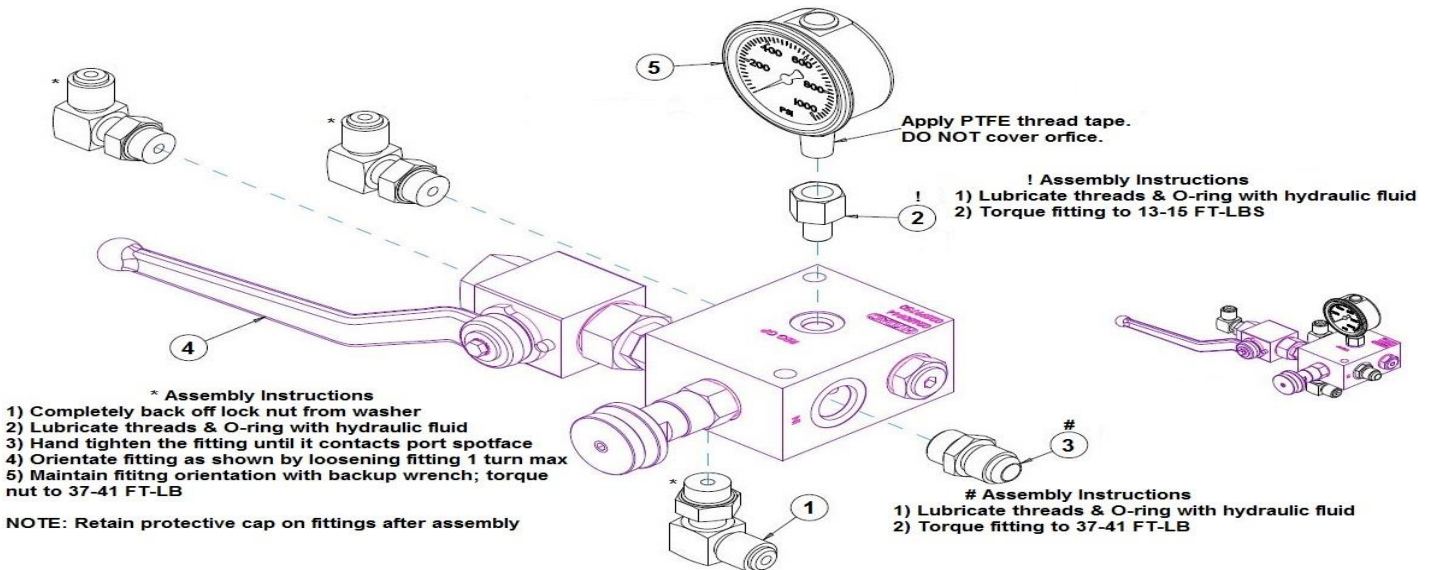

ITEM	PART NUMBER	DESCRIPTION	QUANTITY
1	2515-411	90 DEGREE ELBOW ¾ SAE TO -8 JIC	3
2	2515-434	ADAPTER, -4 ORING / -4 PIPE	1
3	2515-833	¾ SAE TO -8 JIC ADAPTER	1
4	9010-378	PRESSURE REDUCING/BALL VALVE ASSEMBLY	1
5	9010-379	PRESSURE GAUGE, 0 - 1000PSI	1

TROUBLESHOOTING

<u>PROBLEM</u>	<u>CAUSE</u>	<u>SOLUTION</u>
Track Till Tine Penetration	Insufficient pressure on cylinders Track Till Tines Worn	Adjust the pressure higher on the 9010-116 Make Sure the valve assembly is plumbed correctly Replace the Track Till tines
Track Till Tine won't spin freely	Bearings Worn	Replace 9010-399 Bearing Assembly
Track Till Tine leaves dirt/residue over planted row	Track Till Tine configuration set for wide rows	Flip the outside 2 Tine on each axle end for end for less disturbance
Track Till tine assembly out of sequence	Tine spacers worn	Replace tine spacers



A Tradition of Solutions since 1930

Yetter Farm Equipment Co

PO BOX 358 109 S. McDonough

Colchester, IL 62326-0358

Phone: 309-776-4111

Toll Free: 800-447-5777

Email: info@yetterco.com

For updated models and manuals visit the Yetter website:

www.yetterco.com

© Yetter Farm Equipment Co. All Rights Reserved

2565-958_REV_B 08/2024