



# 6010 PLANTER UNIT

OPERATOR'S MANUAL  
&  
PARTS IDENTIFICATION

2565-724\_REV\_H • 06/2024

**YETTER MANUFACTURING CO.**  
*FOUNDED 1930*

Colchester, IL 62326-0358  
Toll free: 800/447-5777  
309/776-3222 (Fax)  
Website: [www.yetterco.com](http://www.yetterco.com)  
E-mail: [info@yetterco.com](mailto:info@yetterco.com)

**YETTER**

## FOREWORD

You've just joined an exclusive but rapidly growing club.

For our part, we want to welcome you to the group and thank you for buying a Yetter product.

We hope your new Yetter products will help you achieve both goals-increase your productivity and increase your efficiency so that you may generate more profit.

This operator's manual has been designed into four major sections: Foreword, Safety Precautions, Installation Instructions and Parts Breakdown.



This **SAFETY ALERT SYMBOL** indicates important safety messages in the manual. When you see this symbol, be alert to the possibility of **PERSONAL INJURY** and carefully read the message that follows.

The word **NOTE** is used to convey information that is out of context with the manual text. It contains special information such as specifications, techniques and reference information of a supplementary nature.

The word **IMPORTANT** is used in the text when immediate damage will occur to the machine due

to improper technique or operation. Important will apply to the same information as specified by note only of an immediate and urgent nature.

It is the responsibility of the user to read the operator's manual and comply with the safe and correct operating procedure and to lubricate and maintain the product according to the maintenance schedule in the operator's manual.

The user is responsible for inspecting his machine and for having parts repaired or replaced when continued use of the product would cause damage or excessive wear to the other parts.

It is the user's responsibility to deliver his machine to the Yetter dealer who sold him the product for service or replacement of defective parts, which are covered by the warranty policy.

If you are unable to understand or follow the instructions provided in this publication, consult your local Yetter dealer or contact:

### **YETTER MANUFACTURING CO.**

309/776-4111

800/447-5777

309/776-3222 (FAX)

Website: [www.yetterco.com](http://www.yetterco.com)

E-mail: [info@yetterco.com](mailto:info@yetterco.com)

## WARRANTY

Yetter Manufacturing warrants all products manufactured and sold by it against defects in material. This warranty being expressly limited to replacement at the factory of such parts or products as shall appear to be defective after inspection. This warranty does not obligate the Company to bear cost of labor in replacement of parts. It is the policy of the Company to make improvements without incurring obligations to add them to any unit already sold. No warranty is made or authorized to be made, other than herein set forth. This warranty is in effect for one year after purchase.

Dealer \_\_\_\_\_

**Yetter Manufacturing warrants its own products only and cannot be responsible for damages to equipment on which mounted.**

## SAFETY PRECAUTIONS

You can make your farm a safer place to live and work if you observe the safety precautions given. Study these precautions carefully and insist those working with you and for you follow the precautions.

Finally, remember this an accident is usually caused by someone's carelessness, neglect or oversight.

**A brief description of signal words that may be used in this manual:**

**CAUTION:** Used as a general reminder of good safety practices or to direct attention to unsafe practices.

**WARNING:** Denotes a specific potential hazard.

**DANGER:** Denotes the most serious specific potential hazard.



### CAUTION

Consult your implement and tractor operator's manual for correct and safe operating practices. Be aware of towed implement width and allow safe clearance.



### CAUTION: SAFETY SIGNS

Safety decals are placed on the implement to alert the operator and others to the risk of personal injury or unsafe operation during normal operations and servicing.

1. The safety decals must be kept clean and in good condition to ensure that they are legible.
2. Safety decals must be replaced if they are missing or illegible.
3. When components are replaced during repair or servicing, check that the new components include the necessary safety signs.
4. Replacement safety decals may be obtained from your local dealer.



### WARNING

Read these instructions carefully to acquaint yourself with the Equipment. Working with unfamiliar equipment can lead to accidents.

Safety shields must always be in place during operation.

Never park the equipment on a steep incline or leave the equipment running unattended.

Never clean, lubricate or adjust a machine that is in motion. Always replace safety shields after servicing.

Do not allow children to operate this equipment.

Do not allow riders on the equipment.

Use speed and caution dictated by the terrain being traversed. Do not operate on any slope steep enough to cause tipping or loss of control.

Be sure all personnel are clear of the immediate area before operating.

Read and understand the operator's manual and require all other persons who will operate the equipment to do the same.

If operating on public roadways, where legal, be certain all lighting is operating properly and observe all traffic laws.

Beware of increased stopping distances and control effort when operating with implements attached.

Be familiar with all controls and be prepared to stop engine and equipment quickly in an emergency.

If seed or seed treatment is dusty or dirty, wear full-face respirator.

**FAILURE TO HEED MAY RESULT IN PERSONAL INJURY OR DEATH.**

## TABLE OF CONTENTS

	PAGE
FORWARD/WARRANTY.....	2
SAFETY INFORMATION.....	3
TABLE OF CONTENTS.....	4
GENERAL INFORMATION/BOLT TORQUE.....	5
HITCH ASSEMBLY INSTRUCTIONS/PARTS IDENTIFICATION.....	6-9
SMV EMBLEM INSTALLATION.....	10
LIGHT KIT INSTALLATION.....	11
PARKING STAND INSTALLATION.....	12
PLANTING UNIT ASSEMBLY INSTRUCTIONS OPERATING THE PLANTER.....	13-23
PREDELIVERY LUBRICATION.....	24-25
STORAGE.....	26
PARTS IDENTIFICATION.....	27-38
TROUBLESHOOTING.....	39

# GENERAL INFORMATION

To achieve maximum performance, this machine must be assembled as outlined in this instruction manual.

The planter operator's manual will NOT include attachment assembly information. Please keep a copy of this instruction available for future attachment assembly.

Information in this instruction manual is divided into sections. These sections are identified at the top of each page.

Read all assembly instructions and carefully observe illustrations.



Leave bolts loose until parts or attachments are completely assembled. Then tighten bolts to torques shown in the following chart unless otherwise specified. It is important that bolts are tight. Loose bolts can cause breakage of parts.

## BOLT TORQUE

### READ THESE INSTRUCTIONS FIRST:

1. Improperly tightened bolts will result in damage, breakage, expense, and down time.
2. Always replace bolts with the specified grade and type.
3. Torque properly before first use of the machine and every 2-4 hours of use until you are sure bolts are staying tight.
4. The chart below is a guide for proper torque. Use it unless a specified torque is called out elsewhere in the manual.
5. Torque is the force you apply to the wrench handle or the cheater bar, times the length of the handle or bar.
6. Use a torque wrench whenever possible.

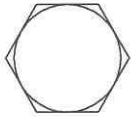
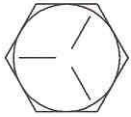
The following table shows torque in ft. lbs.

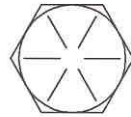
BOLT DIA. AND THREADS PER INCH	 GRADE 2	 OR  GRADE 5      A-325	 GRADE 8
3/8-16	25	35	50
7/16-14	35	55	80
1/2-13	55	85	125
9/16-12	75	125	175
5/8-11	105	170	235
3/4-10	185	305	425
7/8-9	170	445	690
1-8	260	670	1030
1 1/8-7	365	900	1460
1 1/4-7	515	1275	2060
1 3/8-6	675	1675	2700
1 1/2-6	900	2150	3500
1 3/4-5	1410	3500	5600

Lubricate all bearings and moving parts as assembled and make certain that they work freely.

# ASSEMBLY INSTRUCTIONS

**Step 1.** Place the toolbar on two assembly stands approximately 28 inches above the floor or ground.

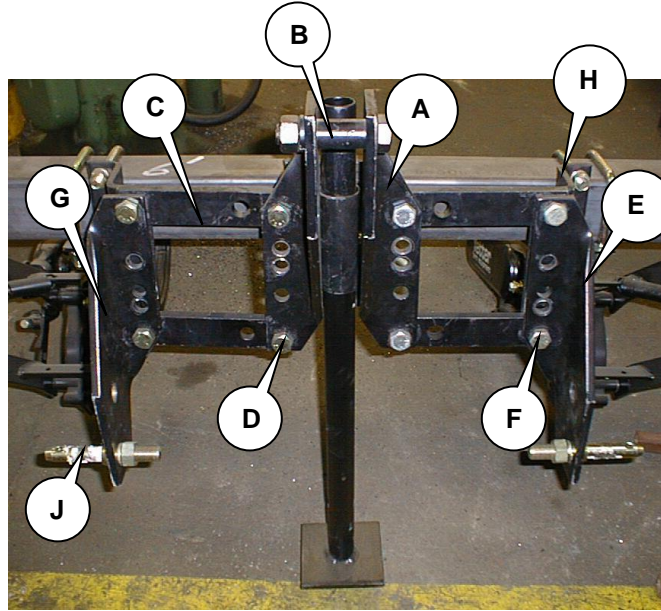

**FRONT VIEW OF HITCH ASSEMBLY**

**Step 2.** Bolt the center mast brackets (A) together using the 1" x 4-1/2" bolt, upper hitch pipe, lock washer and hex nut (B). Also, attach the 6010-303 hitch pin in the lower hole of the upper hitch plates with 1/4 x 2 roll pin and 1/8" hairpin cotter.

**Step 3.** Bolt the 4) mount straps (C) to the center hitch assembly using 4) 3/4" x 2" bolts, lock washers and hex nuts (D).

**Step 4.** Bolt the lower left hitch plate (E) to the end of the mount straps (C) and through the lower hole of the right hand support bracket (H) using the 3/4" x 2-1/2" bolts, lock washers and hex nuts (F).

**Step 5.** Bolt the lower right hitch plate (G) to the end of the mount straps (C) and through the lower hole of the right hand support bracket (I) using the 3/4" x 2-1/2" bolts, lock washers and hex nuts (F).

**Step 6.** Bolt the 7/8" lift pins (J) through the lower hitch plates and attach using the 6010-302 bushing and the lock washer and hex nut included with the lift pins.

**Step 7.** Bolt both the support brackets (H) & (I) to the toolbar using the 5/8-11 x 4 x 5-1/2 u-bolts (K), lock washers and hex nuts.

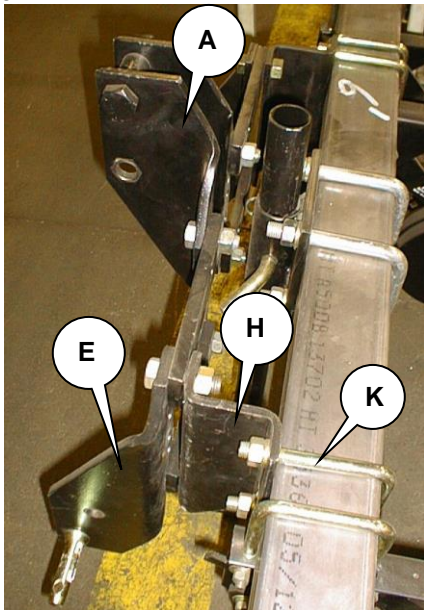

**LEFT HAND TOP VIEW OF HITCH ASSEMBLY**

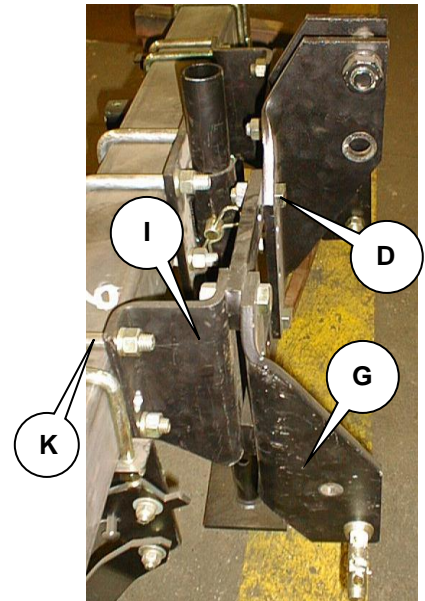

**RIGHT HAND VIEW OF HITCH ASSEMBLY**

# PARTS IDENTIFICATION

## 6010-010 – CAT I HITCH KIT

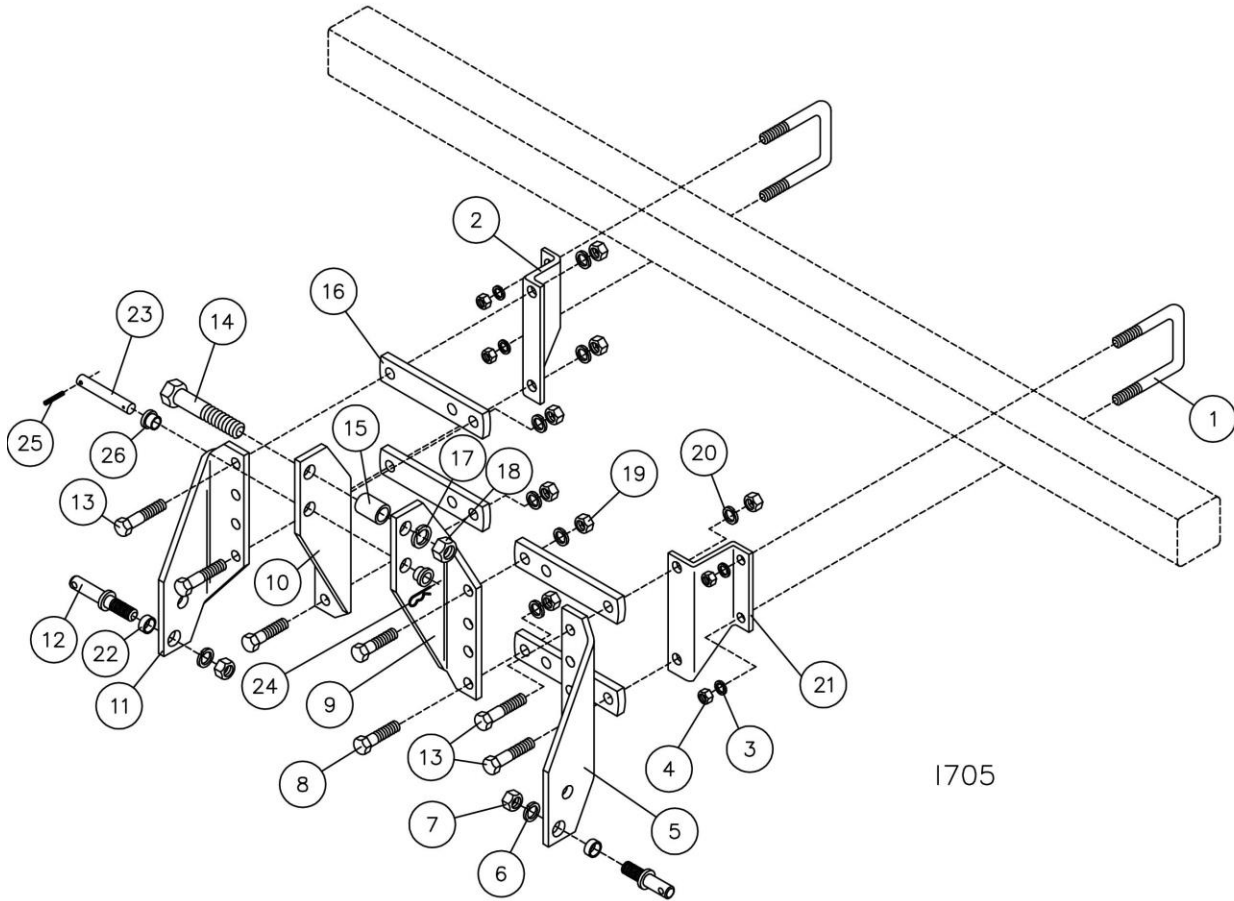

DET	QTY	PART NO.	DESCRIPTION	DET	QTY	PART NO.	DESCRIPTION
1	2	2570-588	5/8-11 X 4 X 5-1/2 U-BOLT ZYD	14	1	2502-768	1-8 X 4-1/2 HHCS GR 5 ZYD
2	1	6700-371	L.H. 4 X 4 SUPPORT BRACKET	15	1	3400-312	UPPER HITCH PIPE
3	4	2525-451	5/8 MED LOCK WASHER ZYD	16	4	2970-324	MOUNT STRAP
4	4	2520-452	5/8-11 HEX NUT ZYD	17	1	2525-550	1" MED LOCK WASHER ZYD
5	1	3400-310	LOWER LEFT HITCH PLATE	18	1	2520-555	1-8 HEX NUT ZYD
6	2	2525-528	7/8 MED LOCK WASHER ZYD	19	8	2520-504	3/4-10 HEX NUT ZYD
7	2	2520-544	7/8-9 HEX NUT ZYD	20	8	2525-501	3/4 MED LOCK WASHER ZYD
8	4	2502-503	3/4-10 X 2 HHCS GR 5 ZYD	21	1	6700-370	R.H. 4 X 4 SUPPORT BRACKET
9	1	3400-308	UPPER LEFT HITCH PLATE	22	2	6010-302	SPACER, HITCH
10	1	3400-309	UPPER RIGHT HITCH PLATE	23	1	6010-303	UPPER HITCH PIN ZYD
11	1	3400-311	LOWER RIGHT HITCH PLATE	24	1	2570-448	1/8 STANDARD HAIRPIN COTTER
12	2	2570-378	7/8 LIFT PIN CAT. I	25	1	2530-153	1/4 X 2 ROLL PIN ZYD
13	4	2502-407	3/4-10 X 2-1/2 HHCS GR 5 ZYD	26	1	6010-304	HITCH STEP SPACER ZYD

UPDATED 03/23/11

# PARTS IDENTIFICATION 6010-004A

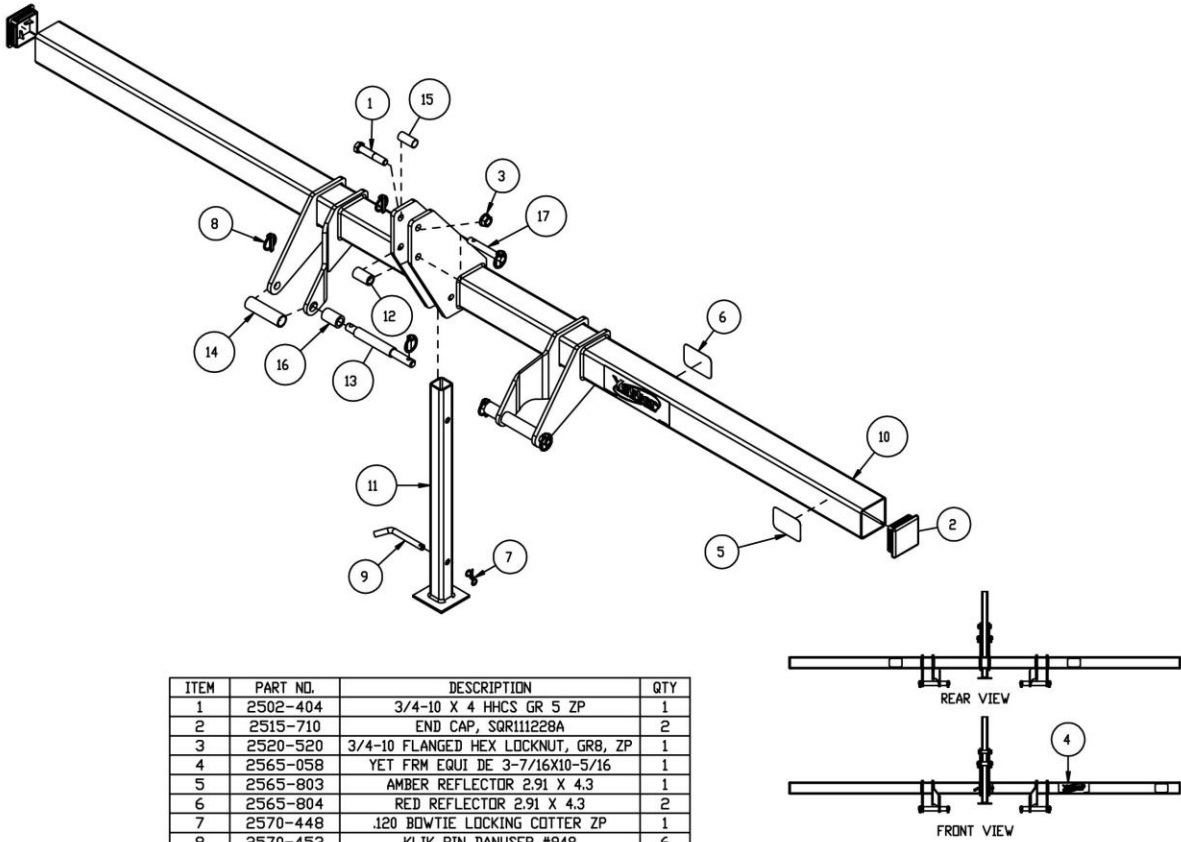

ITEM	PART NO.	DESCRIPTION	QTY
1	2502-404	3/4-10 X 4 HHCS GR 5 ZP	1
2	2515-710	END CAP, SQRI11228A	2
3	2520-520	3/4-10 FLANGED HEX LOCKNUT, GR8, ZP	1
4	2565-058	YET FRM EQUI DE 3-7/16X10-5/16	1
5	2565-803	AMBER REFLECTOR 2.91 X 4.3	1
6	2565-804	RED REFLECTOR 2.91 X 4.3	2
7	2570-448	.120 BOWTIE LOCKING CUTTER ZP	1
8	2570-453	KLIK PIN DANUSER #948	6
9	2984-352	SPRING ADJ. PIN	1
10	6010-200A	PLANTER FRAME W.A., 4 ROW	1
11	6010-201	TOOLBAR STAND W.A.	1
12	6010-429	QUICK HITCH ADAPTER BUSHING, UPPER	1
13	6010-431	CATEGORY 1 & 2 PIN	2
14	6010-432	QUICK HITCH ADAPTER BUSHING, LOWER	2
15	6010-433	ADAPTER BUSHING, UPPER	1
16	6010-434	QUICK HITCH ADAPTER BUSHING, LOWER	2
17	6010-436	3 POINT HITCH PIN, UPPER	1



# PARTS IDENTIFICATION 6010-005A

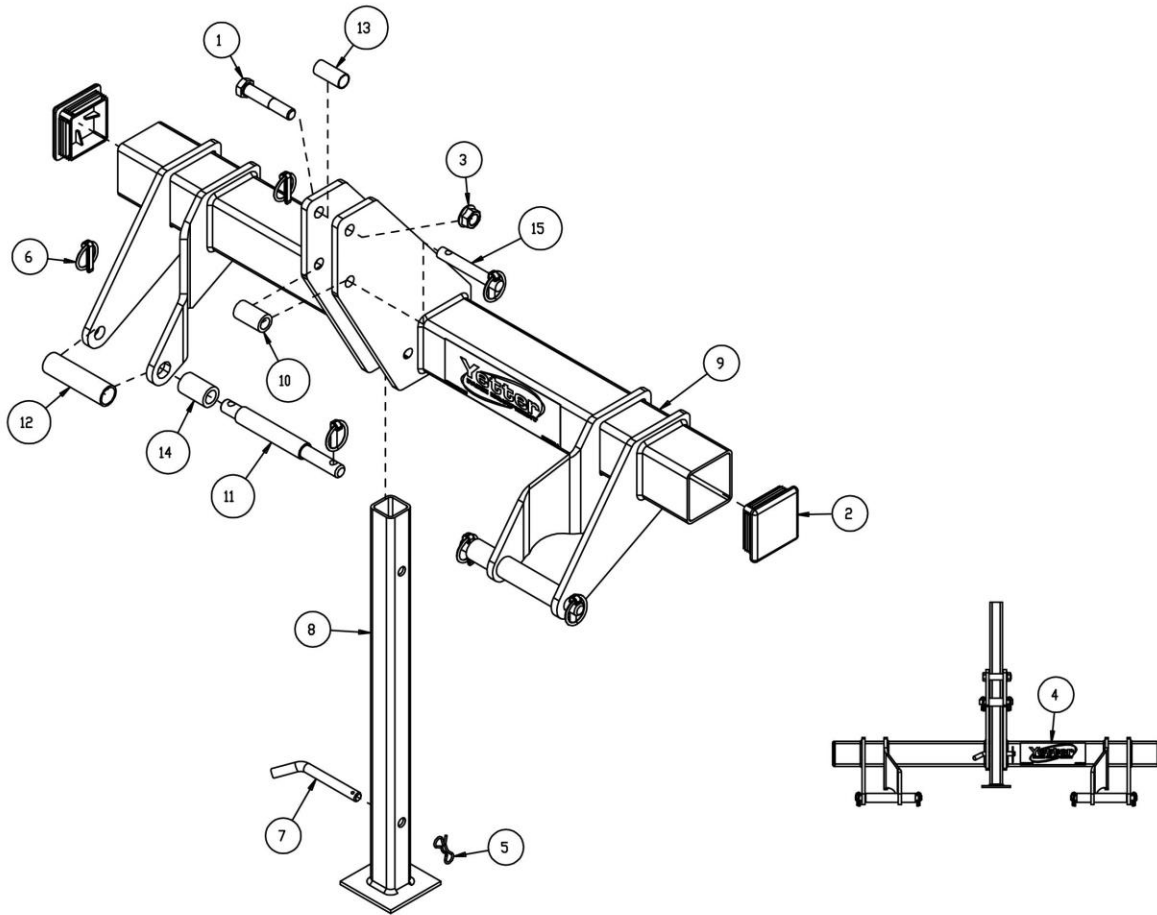

ITEM	PART NO.	DESCRIPTION	QTY
1	2502-404	3/4-10 X 4 HHCS GR 5 ZP	1
2	2515-710	END CAP, SQR111228A	2
3	2520-520	3/4-10 FLANGED HEX LOCKNUT, GR8, ZP	1
4	2565-058	YET FRM EQUI DE 3-7/16X10-5/16	1
5	2570-448	.120 BOWTIE LOCKING COTTER ZP	1
6	2570-453	KLIK PIN DANUSER #948	6
7	2984-352	SPRING ADJ. PIN	1
8	6010-201	TOOLBAR STAND W.A.	1
9	6010-202A	PLANTER FRAME W.A., 2 ROW	1
10	6010-429	QUICK HITCH ADAPTER BUSHING, UPPER	1
11	6010-431	CATEGORY 1 & 2 PIN	2

## SMV EMBLEM INSTALLATION

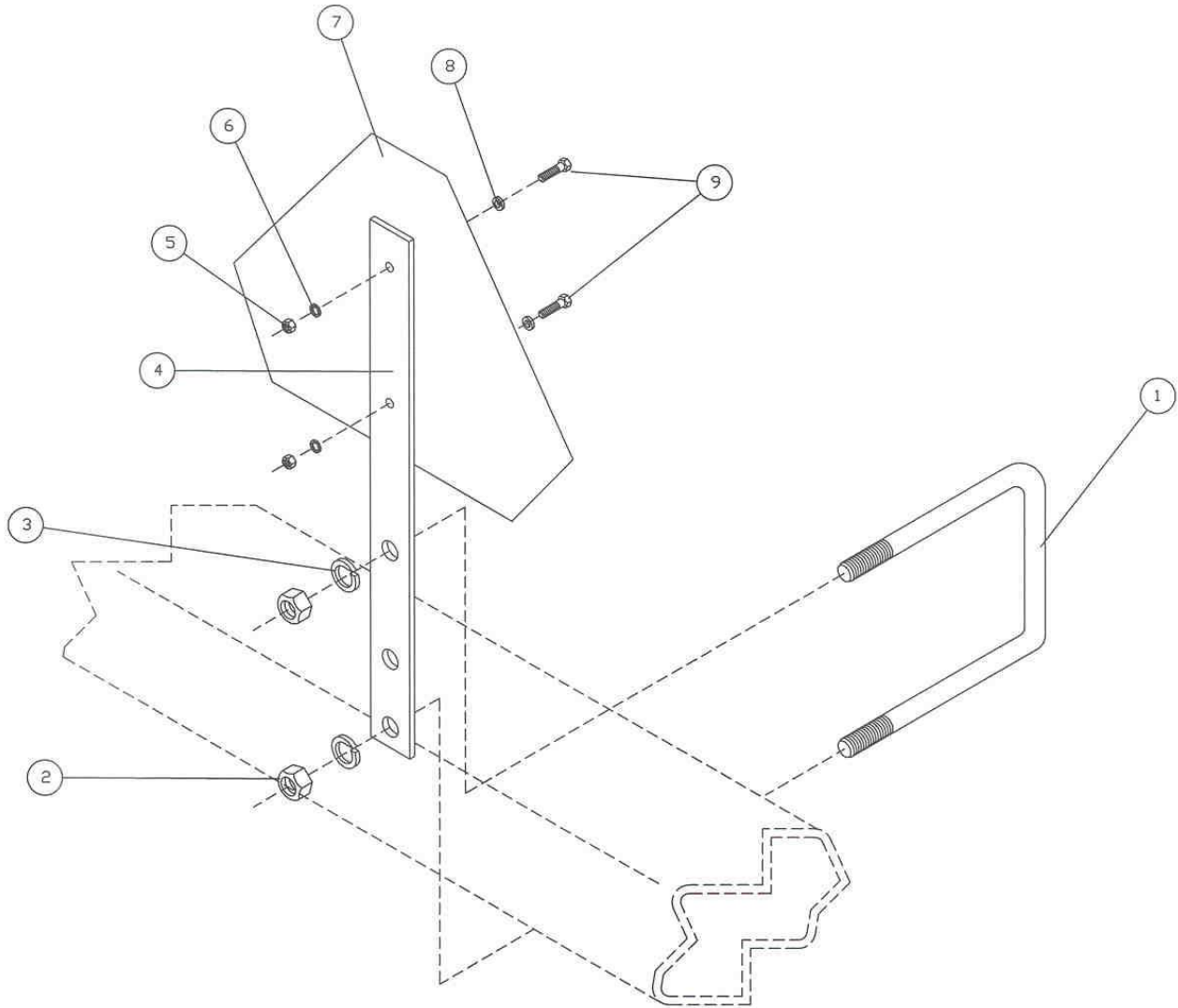

DET	QTY	PART NO.	DESCRIPTION
1	1	2570-475	3/4 X 4 X 6 U-BOLT ZP
2	2	2520-504	3/4-10 HEX NUT ZP
3	2	2525-501	3/4 MED. LOCKWASHER ZP
4	1	3400-377	STRAIGHT SMV BRACKET
5	2	2520-151	1/4-20 HEX NUT ZP
6	2	2525-151	1/4 MED. LOCKWASHER ZP
7	1	2570-472	SMV EMBLEM ALUMINUM BACKED
8	2	2526-151	1/4 STANDARD FLATWASHER ZP
9	2	2502-105	1/4-20 X 3/4 HHCS GR. 5 ZP

# OPTIONAL

## LIGHT KIT INSTALLATION

### 3400-175

#### TOOLBAR LIGHT KIT

DET.	QTY.	PART NO.	DESCRIPTION
1	2	1300-137	AMBER LIGHT ASSEMBLY
2	2	3400-227	LIGHT BRACKET W.A., AMBER LAMP
3	2	2565-808	AMBER REFLECTOR, 1.97 X 6.3"
4	1	2520-357	1/2-3 LOCK HEX NUT ZP
5	2	2520-206	5/16-18 FLANGE LOCK NUT
6	2	1300-436	AMBER LIGHT BRACKET
7	1	2502-300	1/2-13 X 1-1/4 HHCS GR. 2 ZP
8	2	2505-205	5/16-18 X 3/4 CAR BLT GR.5
9	1	1300-448	LAMP, AMBER
10	4	2502-195	M8 X 12MM HHCS GR.5 ZP
11	2	3400-359	LIGHT BRACKET, RED LAMP
12	2	1300-447	LAMP, RED
13	1	1300-446	HARNESS, COMMON WIRING
14	8	2515-405	CABLE TIE, BLACK
15	1	1300-445	MODULE, IMPLEMENT TURN SIGNAL

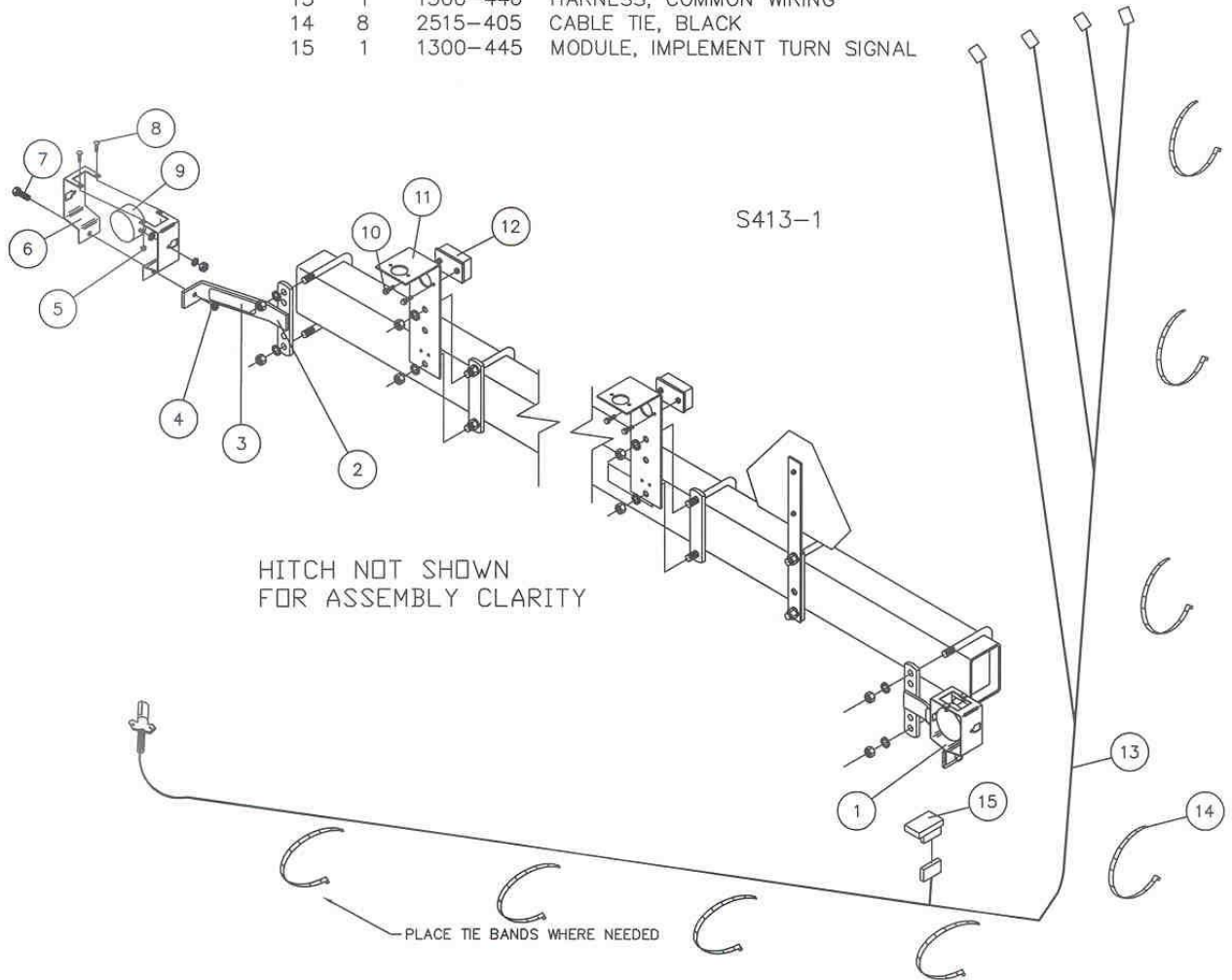

# ATTACHMENT ASSEMBLY INSTRUCTIONS

## PARKING STAND ASSEMBLY

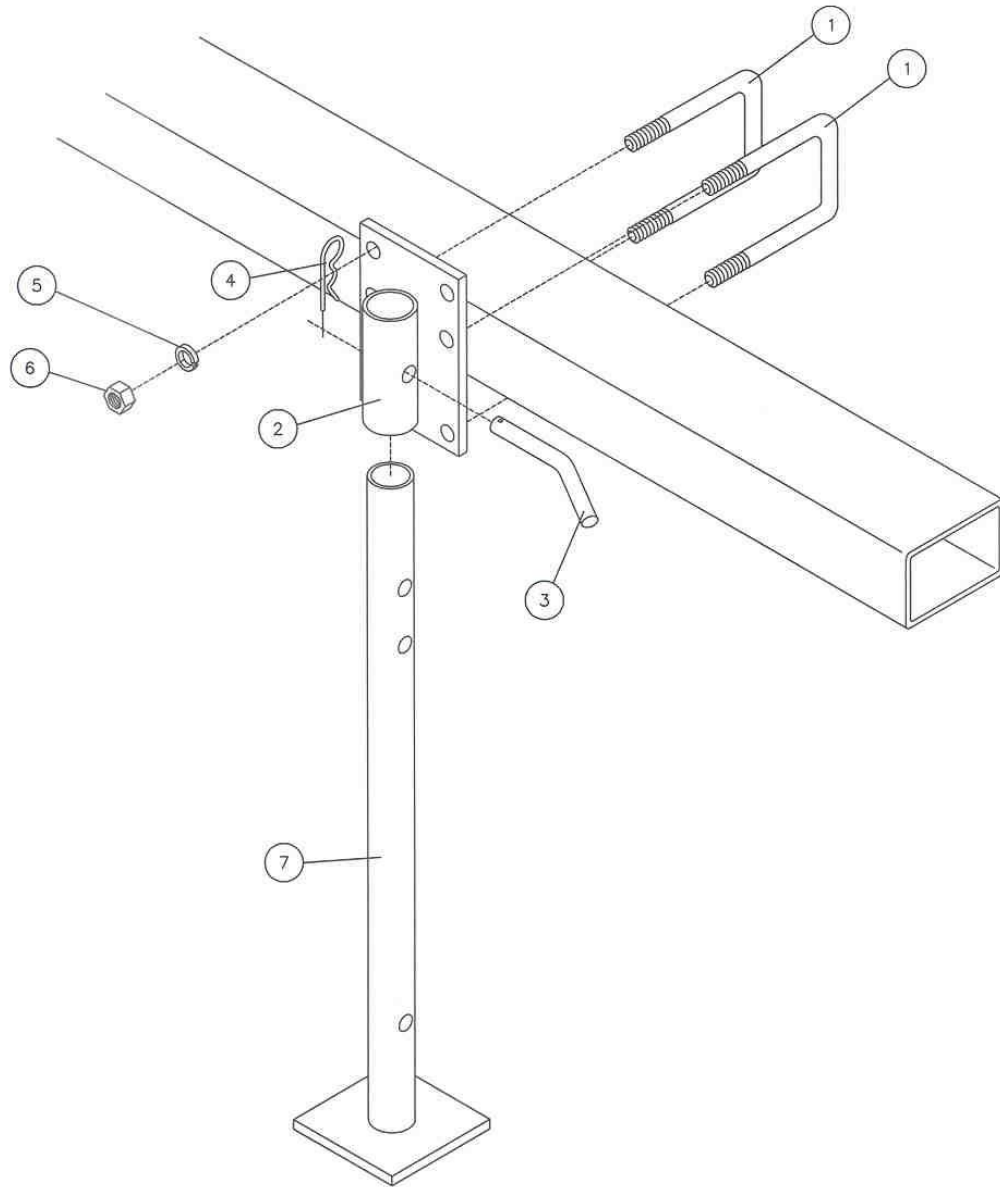

DET	QTY	PART NO.	DESCRIPTION
1	2	2570-475	3/4-10 X 4 X 6 U-BOLT ZYD
2	1	3500-218	STAND BRACKET WA
3	1	3500-333	STAND PIN, ZP
4	1	2570-465	7 GA. HAIRPIN COTTER ZP.
5	4	2525-501	3/4 MED LOCKWASHER ZP
6	4	2520-504	3/4-10 HEX NUT ZP
7	1	3500-217	STAND WA

## PLANTING UNIT ASSEMBLY

**HOPPER BOTTOM-CORN, SOYBEANS,  
ACID DELINTED COTTON AND  
REGULAR-RATE SORGHUM.**

1. Install cutoff (A) in hopper bottom.

NOTE: Be sure cutoff is bottomed in hopper bottom ring as shown above.

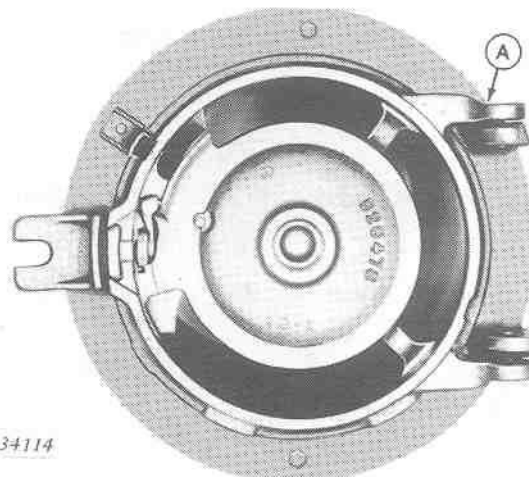

2. Install seed plate (A) and drive plate (B).

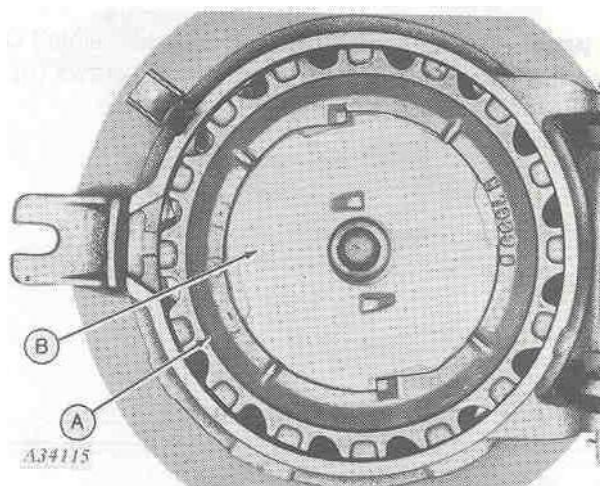

3. Install drive plate retainer in floor plate with retainer (A).
4. Install complete floor plate (B).
5. Secure cutoff and complete floor plate assembly to hopper bottom with hinge pin (C) and cotter pin.
6. Hold parts in place with floor plate spring (D).

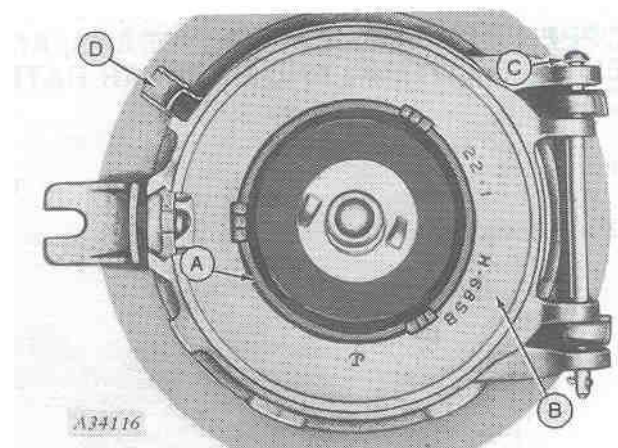



## PLANTING UNIT ASSEMBLY

7. When planting corn, soybeans, or acid-delinted cotton with the fiber glass hopper, remove cap screws (A) from hopper bottom.

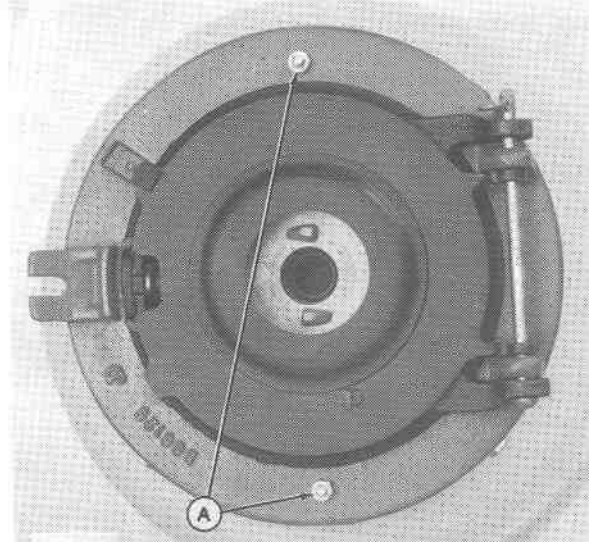

8. Insert  $\frac{1}{4}$  x 3-1/4" bolts (A) through hopper bottom (thread end inside of hopper).

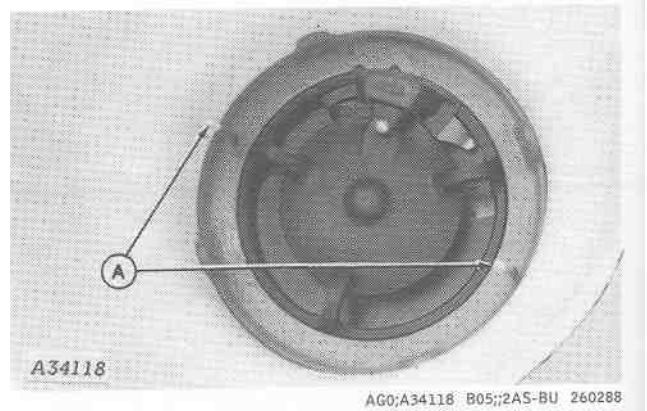

9. Install baffle plate (A) on bolts and secure with springs, flat washers and lock nuts (B).

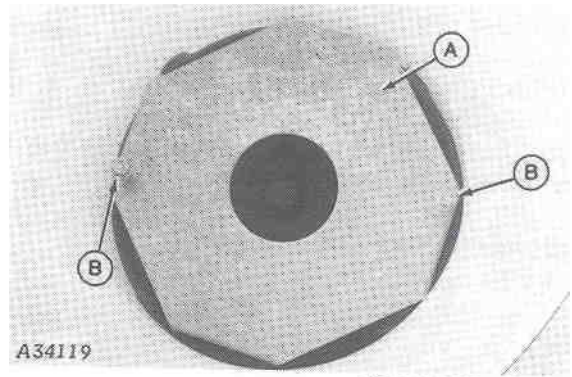

# PLANTING UNIT ASSEMBLY

## HOPPER BOTTOM-BEETS, LOW-RATE SORGHUM OR CUCUMBER

1. Install cutoff (A) in hopper bottom.

NOTE: Be certain cutoff is bottomed in hopper bottom ring.

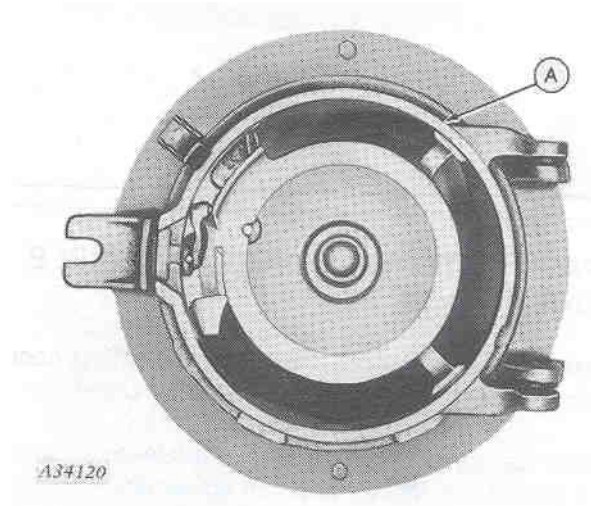

2. Install seed plate (A) and drive plate (B).

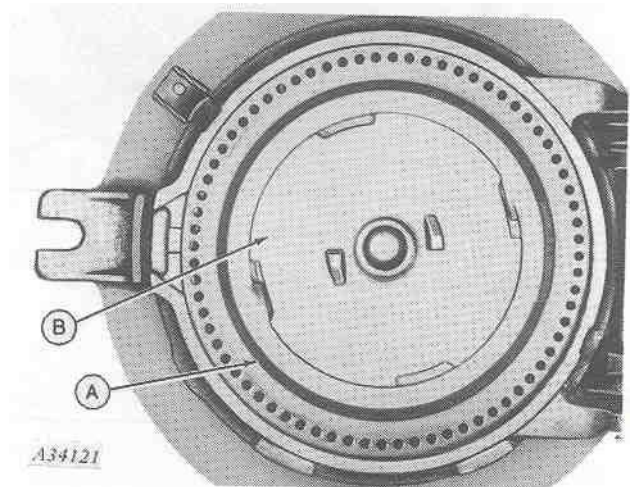

3. Install false ring (A).
4. Install complete floor plate (B).
5. Secure cutoff and complete floor plate assembly to hopper bottom with hinge pin (C) and cotter pin.
6. Hold parts in place with floor plate spring (D).

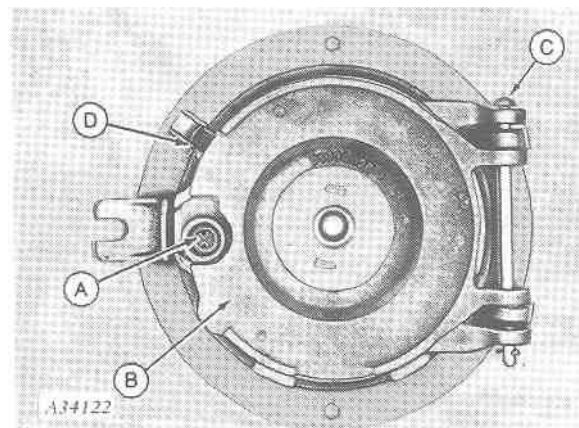

# PLANTING UNIT ASSEMBLY

## HOPPER BOTTOM-PEANUTS OR EDIBLE BEANS

1. Install peanut cutoff (A) and floor plate (B) on hopper bottom and secure with hinge pin (C) and cotter pin.
2. Install recommended peanut seed plate on peanut cutoff with center locator and bolt.

NOTE: Center locator has left-hand thread.

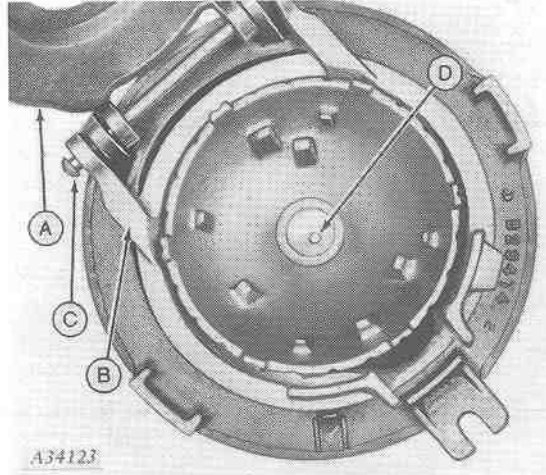

3. Install drive plate (A) on seed plate.

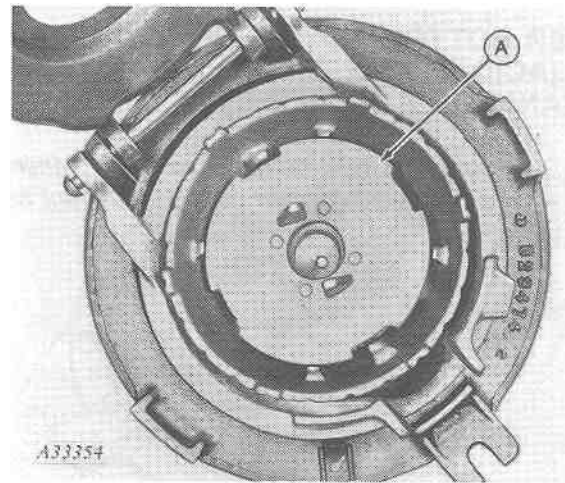

4. Close floor plate (A) and secure with spring (B).

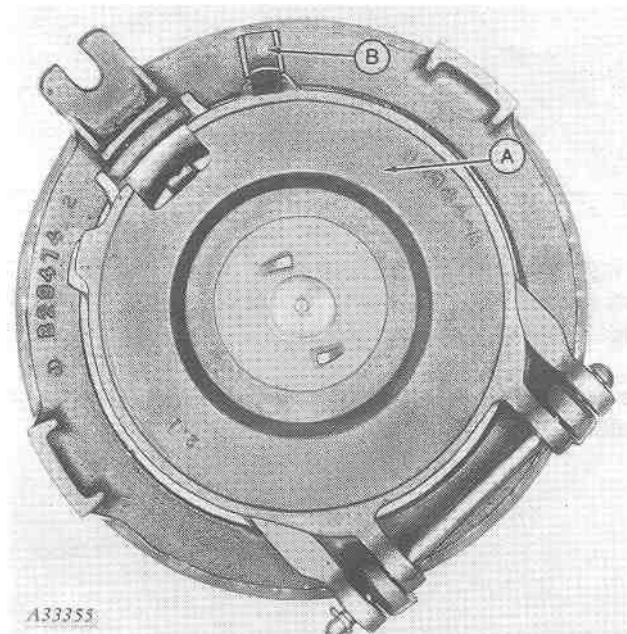



# PLANTING UNIT ASSEMBLY

## **HOPPER BOTTOM-SOYBEANS AND COTTON SEED (ACID, FLAME, ZIP OR MECHANICALLY DELINTED)**

NOTE: Stirring rod (A) must be removed when planting soybeans or acid delinted cotton to prevent hard driving.

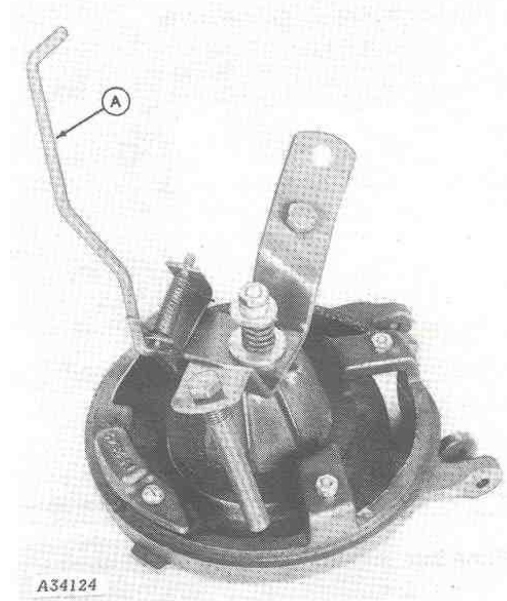

1. Install cutoff (A) and floor plate (B) on hopper bottom and secure with hinge pin (C) and cotter pin. Seat bottom under floor plate spring (D).

Be certain cell filter springs ride directly over cells in seed plate.

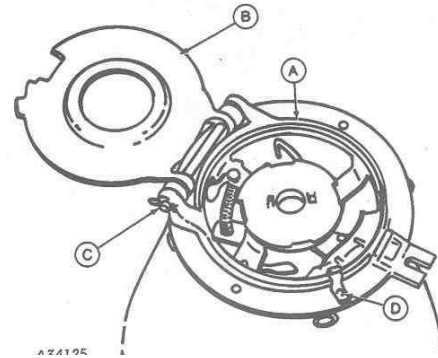

2. Install seed plate (A).

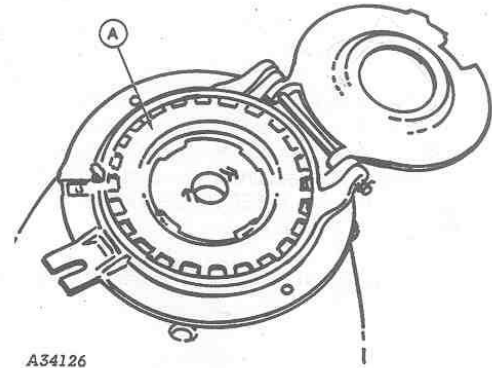

3. Close hopper floor plate and secure under floor plate spring (A).

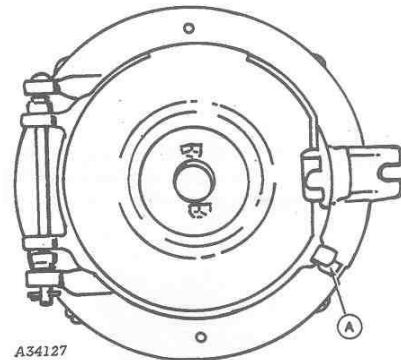

## PLANTING UNIT ASSEMBLY

Install lid and hopper on planting units. Pull latch past locating lug and rotate forward when installing hopper. Secure hopper with latch.



## OPERATING THE PLANTER

**NOTE:** Be sure seed tube (A) is installed in clip (B) as shown at right.

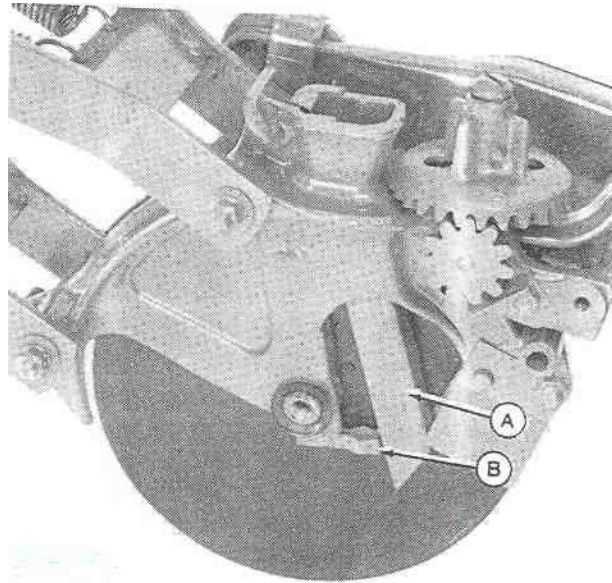

**Double-Disk Seed Opener**

# OPERATING THE PLANTER

## DRILLING DISTANCES

Four sprockets are shipped with each unit; 11-, 14-, 20- and 22-tooth sprockets. These sprockets will give the seed spacing shown on the following page.

The 14-tooth sprocket (A) and 20-tooth sprocket (B) are shipped in place. If other sprocket combinations are desired, remove cap screw (C) and remove sprockets from storage position.

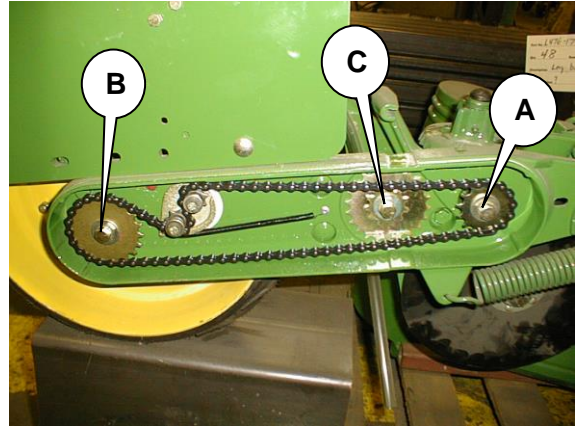

## APPROXIMATE DRILLING DISTANCE IN INCHES

Speed in mph	(Sprocket)		12 Cell	16 Cell	20 Cell	24 Cell	30 Cell	50 Cell	54 Cell	72 Cell
	Press Wheel (Number of Teeth)	Drill Shaft (Number of Teeth)								
1-1/2	22	9	4-1/8"	3-1/8"	2-1/2"	2"	1-5/8"	1"	7/8"	5/8"
2	20	9	4-1/2"	3-3/8"	2-3/4"	2-1/4"	1-3/4"	1-1/8"	1"	3/4"
2	22	11	5"	3-5/8"	3"	2-1/2"	2"	1-1/4"	1-1/8"	3/4"
2	20	11	5-1/2"	4-1/8"	3-1/4"	2-3/4"	2-1/4"	1-3/8"	1-1/4"	7/8"
2-1/2	22	14	6-1/4"	4-3/4"	3-3/4"	3-1/8"	2-1/2"	1-1/2"	1-3/8"	1-1/8"
2-1/2	14	9	6-3/8"	4-3/4"	4"	3-1/4"	2-5/8"	1-1/2"	1-3/8"	1-1/8"
2-1/2	20	14	7"	5-1/4"	4-1/4"	3-1/2"	2-3/4"	1-3/4"	1-5/8"	1-1/4"
3	14	11	7-7/8"	6"	4-3/4"	3-7/8"	3-1/8"	1-7/8"	1-3/4"	1-1/4"
3	11	9	8-1/4"	6-1/8"	5"	4"	3-1/4"	2"	1-3/4"	1-3/8"
3-1/2	22	20	9-1/8"	6-3/4"	5-1/2"	4-1/2"	3-5/8"	2-1/4"	2"	1-1/2"
4	14	14	10"	7-1/2"	6"	5"	4"	2-3/8"	2-1/4"	1-3/4"
4	20	20	10"	7-1/2"	6"	5"	4"	2-3/8"	2-1/4"	1-3/4"
4	20	22	11"	8-1/4"	6-5/8"	5-1/2"	4-3/8"	2-5/8"	2-3/8"	1-7/8"
4-1/2	9	11	12-1/4"	9-1/4"	7-1/4"	6-1/8"	4-7/8"	2-7/8"	2-3/4"	2"
5	11	14	12-3/4"	9-1/2"	7-5/8"	6-3/8"	5-1/8"	3-1/8"	2-3/4"	2-1/8"
5	14	20	14-1/4"	10-3/4"	8-5/8"	7-1/8"	5-3/4"	3-3/8"	3-1/4"	2-3/8"
5	9	14	15-1/2"	11-1/2"	9-1/4"	7-3/4"	6-1/4"	3-3/4"	3-3/8"	2-1/2"
6	14	22	15-3/4"	12"	9-1/2"	7-7/8"	6-3/8"	3-3/4"	3-1/2"	2-5/8"
6-1/2	11	20	18-1/4"	13-5/8"	11-3/8"	9-1/8"	7-1/4"	4-3/8"	4"	3"
7	11	22	20"	15"	12"	10"	8"	4-3/4"	4-3/8"	3-1/4"
8	9	20	22-1/4"	16-5/8"	13-1/4"	11-1/8"	8-7/8"	5-1/4"	4-7/8"	3-3/4"
8	9	22	24-1/2"	18-1/4"	14-3/4"	12-1/4"	9-3/4"	5-7/8"	5-3/8"	4-1/8"

**NOTE:** The 9-tooth sprocket is not available to order.

To obtain the one to one ratio, use two 14-tooth or two 20-tooth sprockets on the same planter. This can be done by pooling the sprockets from two planters or by ordering extra sprockets.

The drilling distances may be doubled by using the extended distance attachment.

See Extended Drilling Attachment in the Attachment section.

In rough field conditions, reduce travel speed to insure proper seed plate cell fill.

Do not exceed the maximum plating speeds in the drilling distance chart or seeds will bounce out of seed plate cells while planting. Vegetable plating also requires smooth seedbed preparation.



# OPERATING THE PLANTER

## LEVELING

Drive tractor and planter on level ground.

Adjust planter frame to 16 inches (405 mm) above ground.

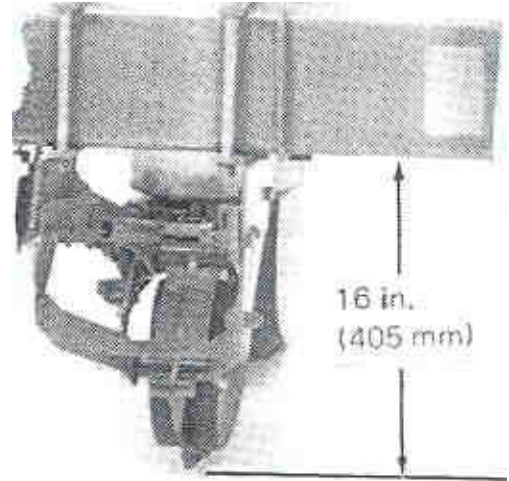

## CHANGING PLANTING DEPTH

The press wheel gauges the planting depth. The adjustment is from surface plating to 3-1/2 in. (90 mm) deep.

To adjust depth, pull out adjustment stop (A) and turn depth control cam (B) to position desired. The numbers on the depth control cam are only to be used as a guide. Release the handle to lock cam in position.

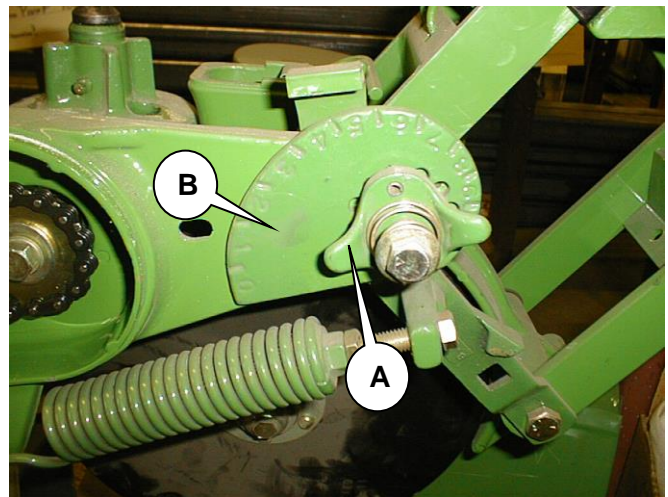

Depth control cam should rest against the stop (A) in planting position. If the cam does not rest on the stop, loosen the jam nut (B) on the down pressure spring and loosen the down pressure spring bolt (C) until the depth cam is resting on the stop. Tighten jam nut.

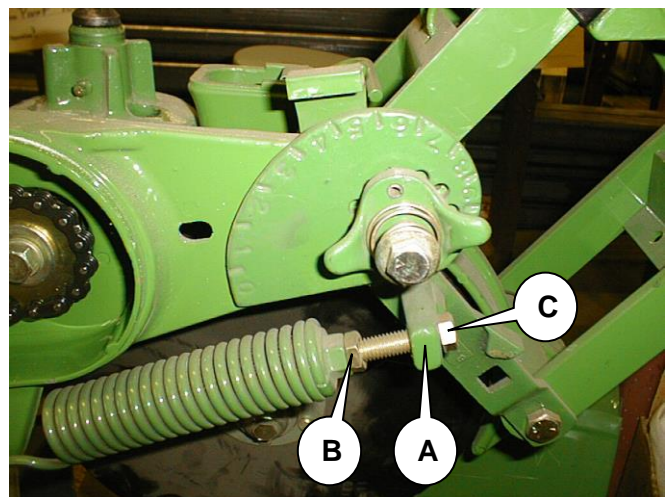

## OPERATING THE PLANTER

Two holes (B) and (C) in the main chain housing (A) permit finer adjustment. To increase the planting depth slightly with the adjustment stop pin in hole (B) proceed as follows:

Insert the adjustment stop pin into hole (D) and turn to the left until it locks the depth control cam in position in hole (C) in the chain housing.

To decrease the planting depth slightly with the adjustment stop pin set in hole (B) proceed as follows:

Insert the adjustment stop pin into hole (E) and turn to the right until it locks the depth control cam in position in hole (C) in the chain housing.

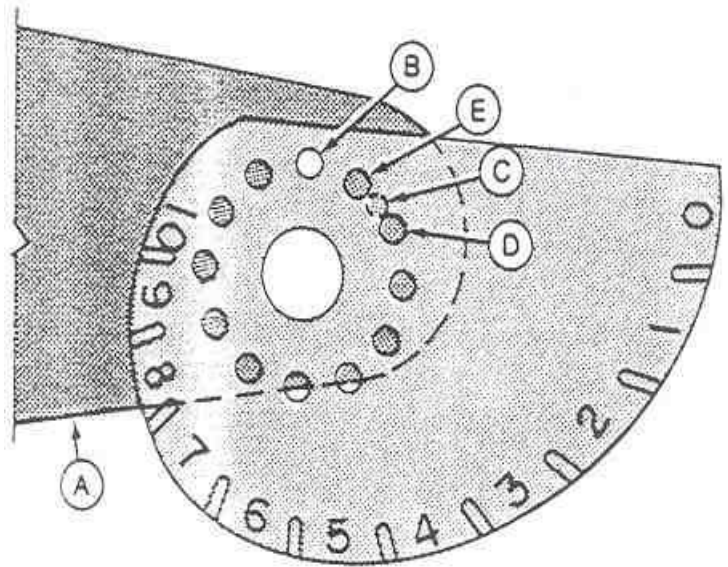

### ADJUSTING PRESS WHEEL DOWN FORCE ON SQUARE TOOLBAR

Raise planter to transport position.

Adjust unit down pressure by changing position of spring adjusting arms.

Place a  $\frac{3}{4}$  in. open-end wrench on end of adjusting arm, remove pin (A) and move arm to desired position. The bottom hole (B) is maximum down pressure.

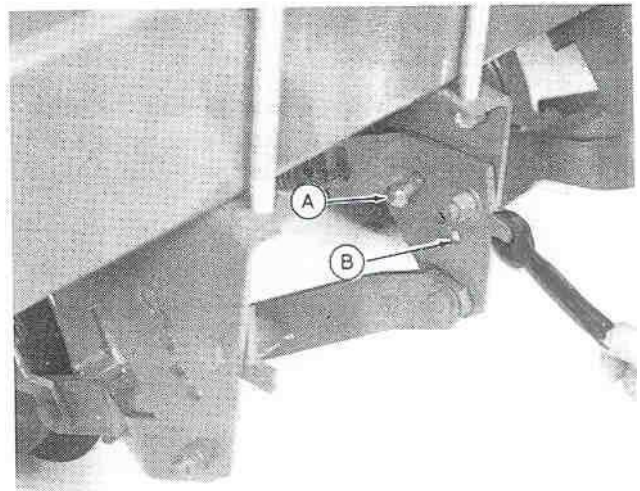

# OPERATING THE PLANTER

## CENTERING PRESS WHEEL

If press wheel (A) does not track directly behind seed opener (B), loosen round head bolts (C) behind drive chain housing.

Align press wheel so drive chain housing is at right angle to the toolbar. Tighten round head bolts.

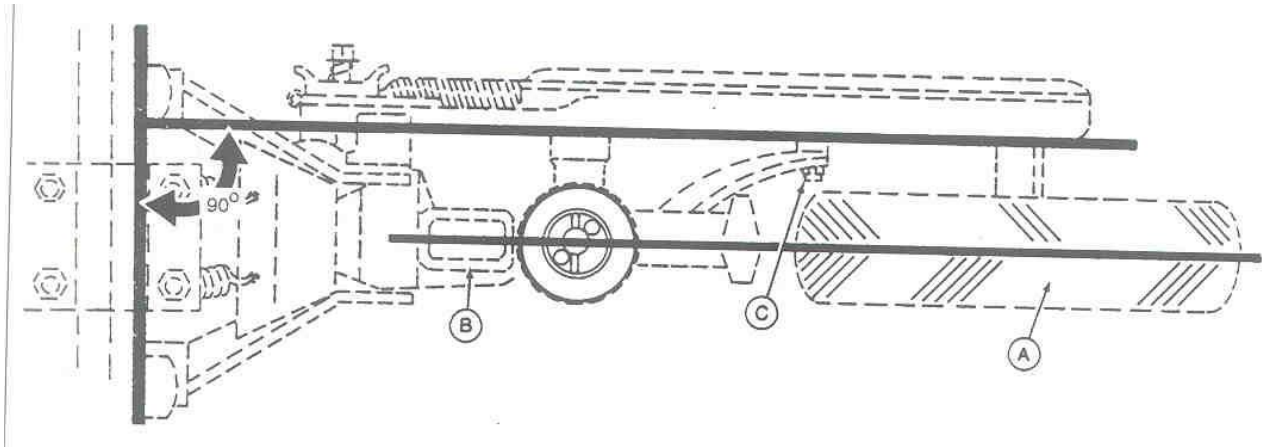

If press wheel frame becomes loose, loosen jam nut on bolt (A) and tighten bolt. Tighten jam nut. If press wheel does not float, loosen jam nut and bolt (A). Tighten jam nut.

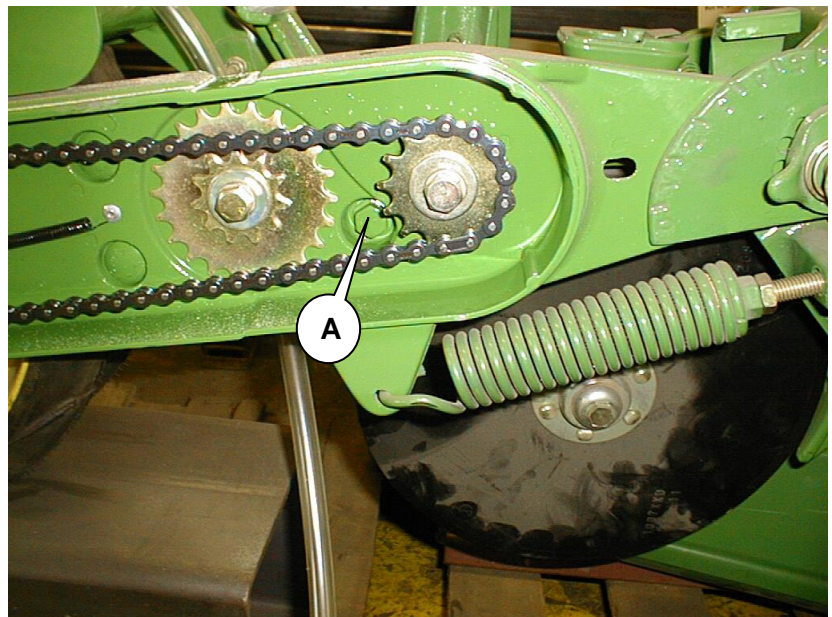



# OPERATING THE PLANTER

## PLANT POPULATION

### APPROXIMATE PLANT POPULATION PER ACRE

Distance Between Seed in In.	30 In. Row Spacing	32 In. Row Spacing	38 In. Row Spacing	40 In. Row Spacing
1	209,100	196,000	165,100	156,800
2	104,500	98,000	82,500	78,400
3	69,700	65,300	55,000	52,300
4	52,300	49,000	41,300	39,200
5	41,800	39,200	33,000	31,400
6	34,800	32,700	27,500	26,100
7	29,900	28,000	23,600	22,400
8	26,100	24,500	20,600	19,600
9	23,200	21,800	18,300	17,400
10	20,900	19,600	16,500	15,700
11	19,000	17,800	15,000	14,300
12	17,400	16,300	13,800	13,100

## CHECKING PLANT POPULATION

Raise the unit, place a container under the double-disk opener and turn the press wheel five complete revolutions.

Multiply the number of seeds you have collected by the factor shown in the chart below for the row width you are using to find the approximate plant population per acre.

Row Width in In.	Factor	Row Width in In.	Factor
14	1613	28	806
16	1411	30	753
18	1254	32	706
20	1129	34	664
22	1026	36	627
24	941	38	594
26	869	40	564

Example:

For 30 in. row spacing, your factor from the chart above is 753 and you have collected 28 seeds.

Multiply the row width factor (753) by (28) seeds and you will get an approximate plant population per acre of 21,084.

# PREDELIVERY LUBRICATION

## ***PREDELIVERY LUBRICATION***

Note that lubrication intervals are identical to those appearing in the operator's manual. Regardless of recommended intervals, lubricate the planter before delivery at every point shown in the charts with multi-purpose lubricant or an equivalent SAE multi-purpose type grease.

When you deliver the planter, the time interval information will remind you to tell your customer of the importance of lubrication intervals recommended in the planter operator's manual.

If any grease fittings are missing, replace them immediately. Clean fittings thoroughly before using grease gun.

## ***LUBRICATION SYMBOLS***



Lubricate with general purpose grease at hourly interval indicated on symbol.



Pack wheel bearings with axle grease at hourly interval indicated on symbol.



Lubricate with SAE 10W oil at hourly interval indicated on the symbol.

## ***ALTERNATIVE LUBRICANTS***

Conditions in certain geographical areas may require special lubricants and lubrication practices which do not appear in this manual. If you have any questions, consult you dealer to obtain the latest information and recommendations.



# LUBRICATION

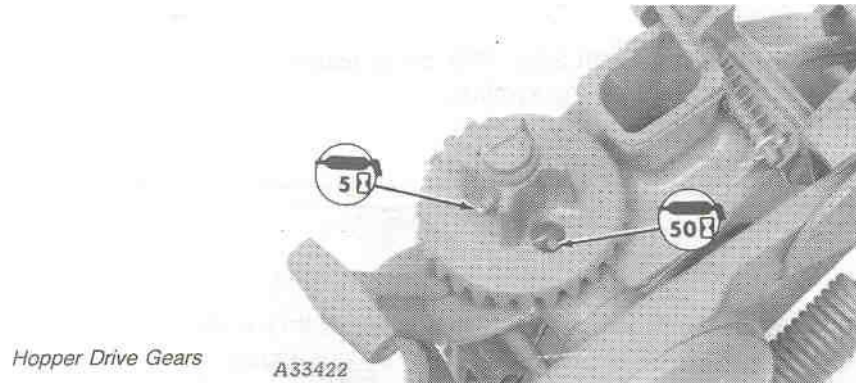

## ROLLER CHAIN LUBRICATION

The most effective roller chain lubrication routine varies, depending on the environmental conditions and/or conditions of the chain. The obvious goal is to maintain complete freedom at every chain link joint.

For best results, DO NOT lubricate roller chains if operating in dusty conditions. Lubrication will only tend to pull additional grit into the critical pivot areas, restricting free chain movement.

If operating in clean and/or moist conditions, lubricate the roller chains with PT508 chain lube spray (or equivalent) at intervals sufficient to maintain free chain movement.

When roller chains remain unused for several days, moisture in the air will accumulate on the chain causing the chain to rust. This can and will become serious enough in time to cause the chain joints to become stiff, restricting their normal free movement. While very difficult to detect, this stiffness can encourage the chains to operate abnormally and disturb the smooth rotation of important meter components causing a deterioration in performance.

If the planter is not to be used for several days, thoroughly lubricate the chains with PT508 chain lube at the beginning of the idle period. If the roller chains have become rusty or stiff during the idle period, lubricate prior to continued usage and operate or “work” the chains sufficiently to insure all chain joints move freely before normal planter operation is resumed.

## SPECIAL LUBRICATNS FOR SEED HOPPERS

**IMPORTANT:** With plate type hoppers, sprinkle a teaspoon of powdered graphite over the top of the seed twice a day.

# STORAGE

## **BEGINNING OF THE SEASON SERVICE**

Before using the planter after it has been stored, inspect the seed hoppers for cleanliness to be certain the seed will flow from hoppers freely.

Thoroughly inspect the planter unit for loose parts and adjust as necessary.

Clean any dirt or grease that may have accumulated on moving parts, gears and chains before operating the planter. This will prevent abrasive action that could cause excessive wear.

When roller chains remain unused for several days, moisture in the air will accumulate on the chain, causing the chain to rust. This can, and will, become serious enough in time to cause the chain joints to become stiff, restricting the normal free movement. While very difficult to detect, this stiffness can encourage the chains to operate abnormally and disturb the smooth rotation of important meter components, causing deterioration in performance.

If the planter is not used for several days, or if oil has been removed from chains, etc. while cleaning the planter, thoroughly lubricate chains with multipurpose spray lube.

## **END OF THE SEASON SERVICE**

When planting is completed for one season, store the planter under cover with all parts in operating condition.

Paint all parts which are chipped or worn and require repainting.

Clean the planter thoroughly to remove dirt and trash which would hold moisture and cause rusting.

Lubricate the planter as outlined in the Lubrication section and grease exposed cylinder rods.

If the planter is not to be used for several days, or if oil has been removed from chains, etc. while cleaning the planter, thoroughly lubricate chains with Multipurpose Spray Lube at the beginning of the idle period. If roller chains have become rusty or stiff during the idle period, lubricate prior to continued usage and operate or "work" chains sufficiently to insure all chain joints move freely before normal planter operation is resumed.

Empty and clean seed hoppers.

Clean insecticide and/or herbicide hopper thoroughly as various chemicals may deteriorate the system components.

Inspect the planter for worn or broken parts. See your dealer during the off season so that parts or service can be acquired when the planter is not needed in the field.

Store the units in a clean, dry place, with the press wheel out of the sun and off of the floor. Do not let the unit rest on the press wheel in storage, as this will reduce its life.

## PARTS IDENTIFICATION 6010-020 ROW UNIT ASSEMBLY

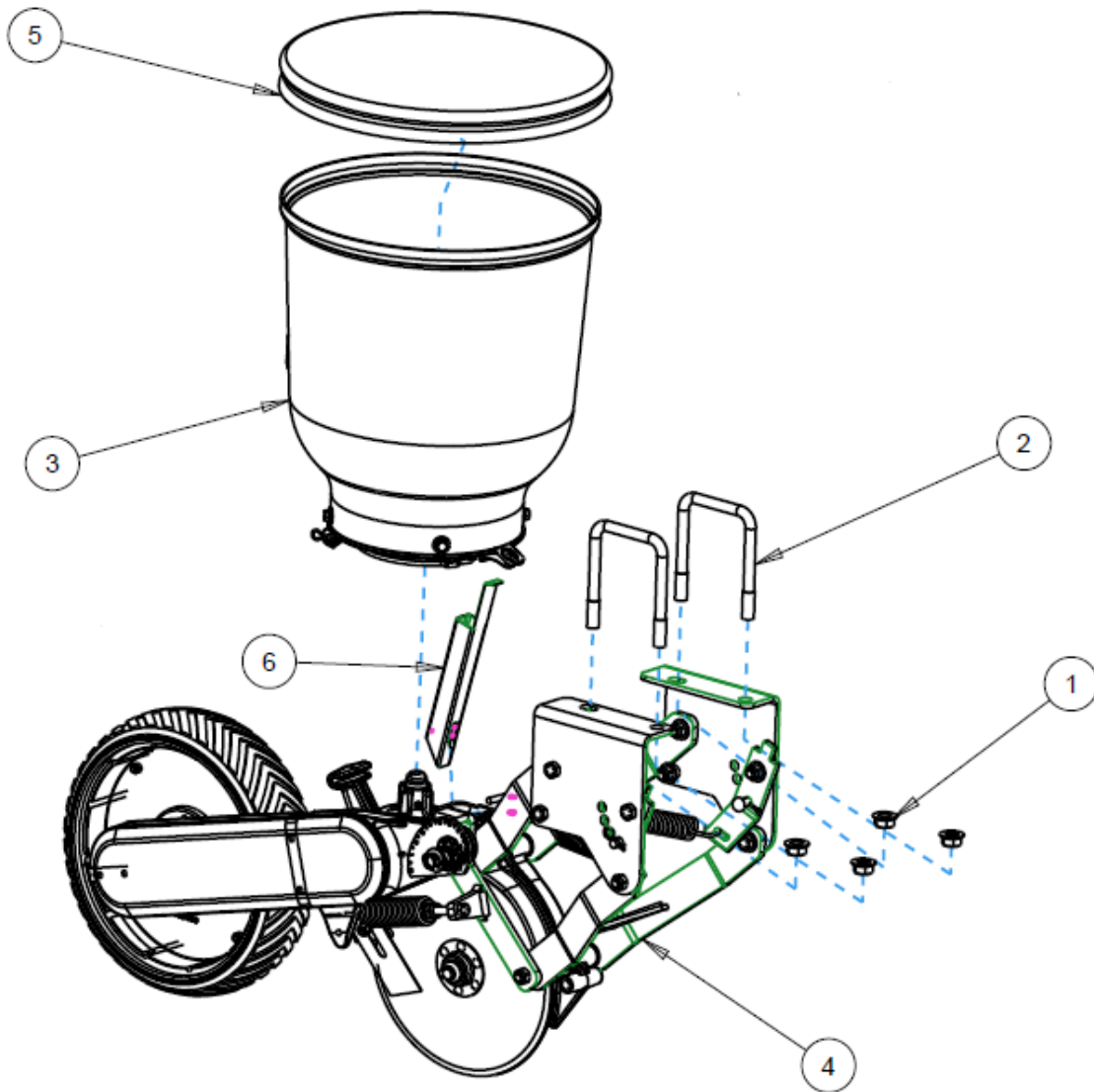

ITEM	PART NO.	DESCRIPTION	QTY
1	2520-464	5/8-11 FLANGE LOCK NUT GRADE 2	4
2	2570-588	5/8 X 4 X 5.5 U-BOLT	2
3	6010-126	HOPPER ASSEMBLY	1
4	6010-170	PLANTER UNIT ASSEMBLY	1
5	6010-300	LID	1
6	6010-337	SEED TUBE	1

## PARTS IDENTIFICATION 6010-126 HOPPER ASSEMBLY

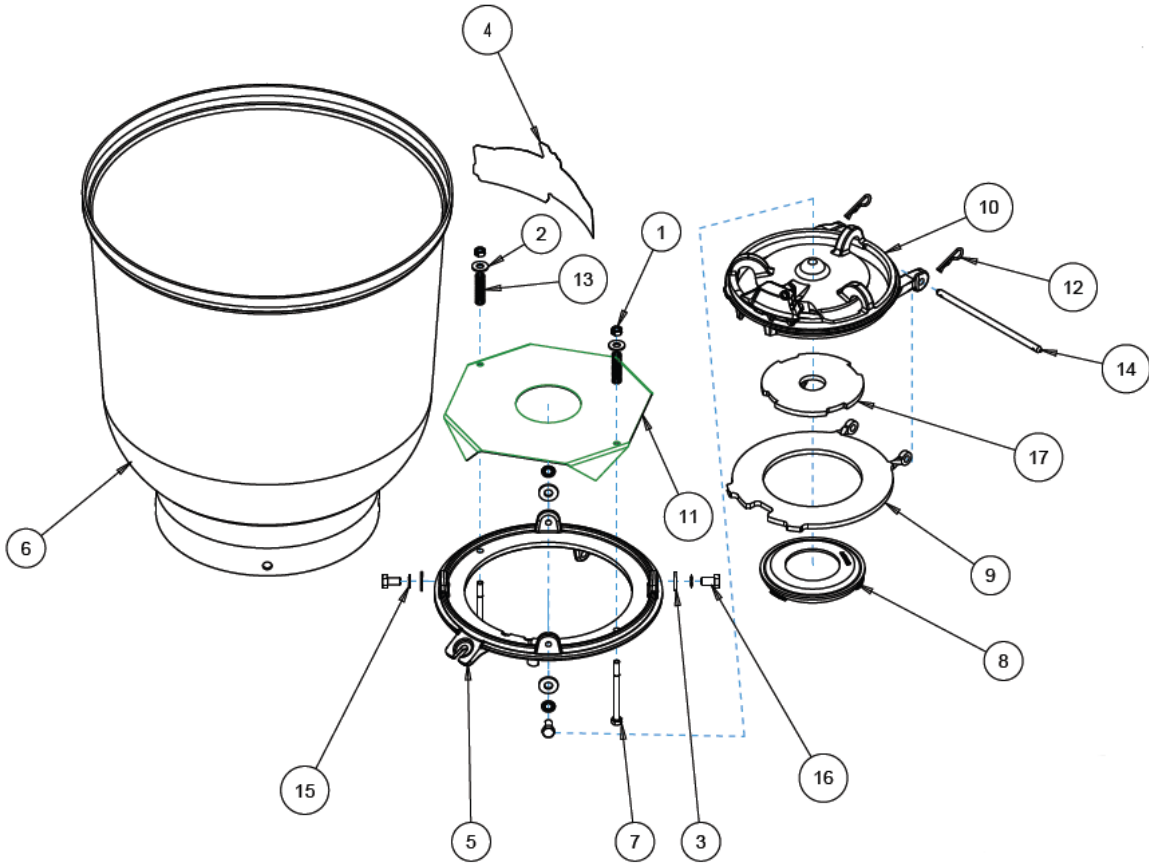

ITEM	PART NO.	DESCRIPTION	QTY
1	2520-152	1/4-20 LOCK NUT	2
2	2526-151	1/4 FLATWASHER	2
3	2526-201	5/16 FLATWASHER	4
4	2565-851	DECAL	1
5	6010-160	HOPPER BOTTOM	1
6	6010-301	SEED HOPPER	1
7	6010-316	1/4-20 X 3.75" CAP SCREW GRADE 2	2
8	6010-330	RETAINER	1
9	6010-331	PLATE	1
10	6010-332	CORN CUT-OFF ASSEMBLY	1
11	6010-389	BAFFLE	1
12	6010-401	HAIRPIN	2
13	6010-413	COMPRESSION SPRING	2
14	6010-416	PIN	1
15	6010-420	5/16 LOCK WASHER SPLIT	4
16	6010-421	5/16-18 X 5/8 CAP SCREW GRADE 2	4
17	6010-361	DRIVE PLATE	1

# PARTS IDENTIFICATION 6010-170 PLANTER UNIT ASSEMBLY

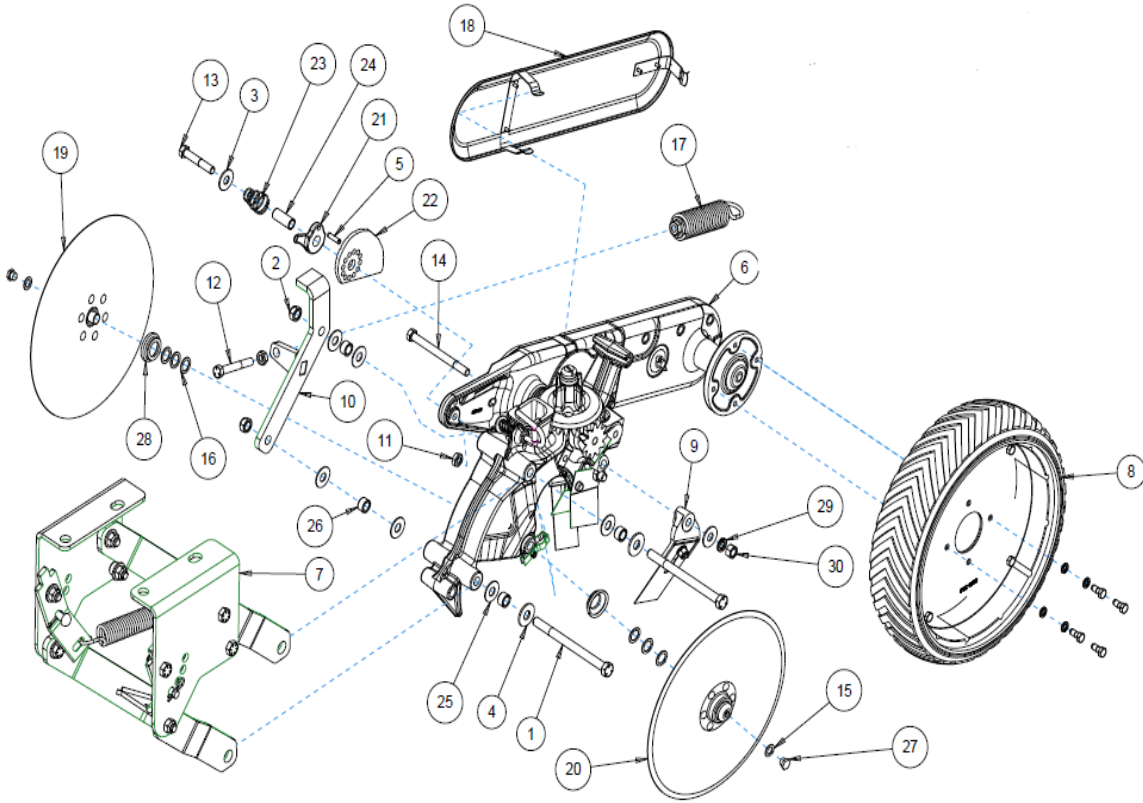

ITEM	PART NO.	DESCRIPTION	QTY
1	2502-372	½-13 X 6.5 CAP SCREW GRADE 5	2
2	2520-362	½-13 LOCK NUT GRADE 8	2
3	2526-301	7/16 FLAT WASHER	3
4	2526-351	½ FLAT WASHER	2
5	2530-154	¼ X 1 ROLL PIN	1
6	6010-121	BODY SUB-ASSEMBLY	1
7	6010-128	MOUNT BRACKET ASSEMBLY	1
8	6010-151	TIRE ASSEMBLY	1
9	6010-152-S	SCRAPER ASSEMBLY	2
10	6010-204	BRACKET SPRING ANCHOR	1
11	6010-311	7/16-14 JAM NUT GRADE 5	2
12	6010-313	7/16-14 X 3 CAP SCREW FULL THREAD	1
13	6010-314	7/16-14 X 2.5 CAP SCREW GRADE 2	1
14	6010-318	7/16-14 X 5 CAP SCREW GRADE 2	1
15	6010-321	WASHER	2
16	6010-323	WASHER SHIM	6
17	6010-333	SPRING ASSEMBLY	1
18	6010-335	COVER	1
19	6010-339	BLADE RIGHT HAND	1
20	6010-340	BLADE LEFT HAND	1
21	6010-352	STOP	1
22	6010-354	CAM DEPTH ADJUST	1
23	6010-358	SPRING	1
24	6010-359	SPACER	1
25	6010-396	WASHER	6
26	6010-398	PIVOT BUSHING	4
27	6010-407	PLUG	2
28	6010-409	SEAL	2
29	2525-301	7/16 SPLIT LOCK WASHER	1
30	2520-303	7/16-14 HEX NUT	1

# PARTS IDENTIFICATION

## SEED HOPPER ASSEMBLY

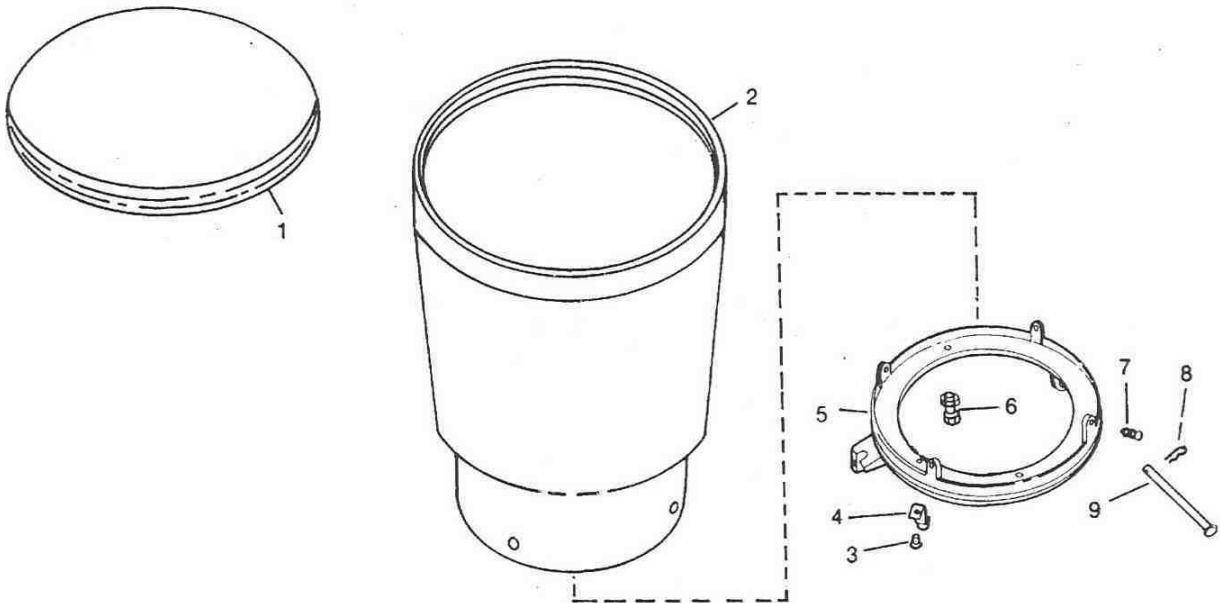

KEY	QTY.	PART NO.	DESCRIPTION
1.	1	6010-300	LID, HOPPER
2.	1	6010-301	SEED HOPPER, 71 ROW UNIT
3.	1	6010-414	1/8 X 1/2 RIVET
4.	1	6010-369	SPRING
5.	1	6010-393	PLATE
6.	2	2502-105	1/4-20 X 3/4 HHCS GR 5 ZYD
	2	2520-151	1/4-20 HEX NUT ZYD
7.	4	2502-200	5/16-18 X 3/4 HHCS GR 2 ZYD
	4	2525-201	5/16 MED LOCK WASHER ZYD
	4	2526-201	5/16 STANDARD FLAT WASHER ZYD
8.	2	6010-401	SPRING LOCKING PIN
9.	1	6010-416	PIN

# PARTS IDENTIFICATION

## PARALLEL ARMS AND TOOLBAR SUPPORTS

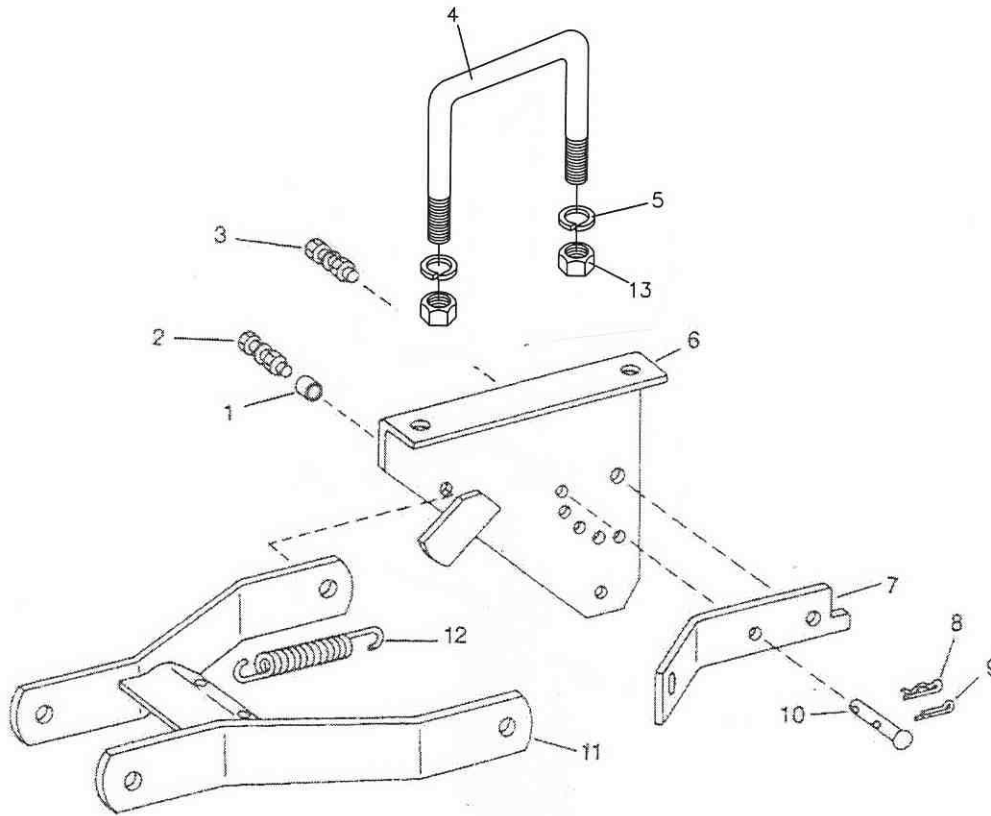

KEY	QTY.	PART NO.	DESCRIPTION
1.	8	6010-398	BUSHING
2.	4	2502-294	1/2-13 X 1-1/2 HHCS GR 5 ZYD.
	4	2525-352	1/2 MED LOCK WASHER ZYD.
	4	2520-352	1/2-13 HEX NUT ZYD.
	4	2526-352	1/2 SAE FLAT WASHER ZYD.
3.	2	2502-294	1/2-13 X 1-1/2 HHCS GR 5 ZYD.
	2	2520-357	1/2-13 HEX LOCK NUT ZYD.
	2	2526-352	1/2 SAE FLAT WASHER ZYD.
	2	6010-397	BUSHING
4.	2	2570-758	5/8-11 U-BOLT (2-1/2")
	2	2570-602	5/8-11 U-BOLT (3")
	2	2570-588	5/8-11 U-BOLT (4")
	2	2570-626	5/8-11 U-BOLT (7")
5.	4	2525-451	5/8 MED LOCK WASHER ZYD.
6.	1	6010-342	R.H. SUPPORT (SHOWN)
	1	6010-343	L.H. SUPPORT
7.	1	6010-325	ARM, L.H. (SHOWN)
	1	6010-324	ARM, R.H.
8.	2	6010-401	SPRING LOCKING PIN
9.	1	2531-107	1/8 X 1 COTTER PIN ZYD.
10.	2	6010-391	PIN
11.	2	6010-341	ARM
12.	2	6010-390	SPRING
13.	4	2520-452	5/8-11 HEX NUT ZYD.



# PARTS IDENTIFICATION

## HOPPER DRIVE CASE ASSEMBLY AND DEPTH ADJUSTMENT CAM

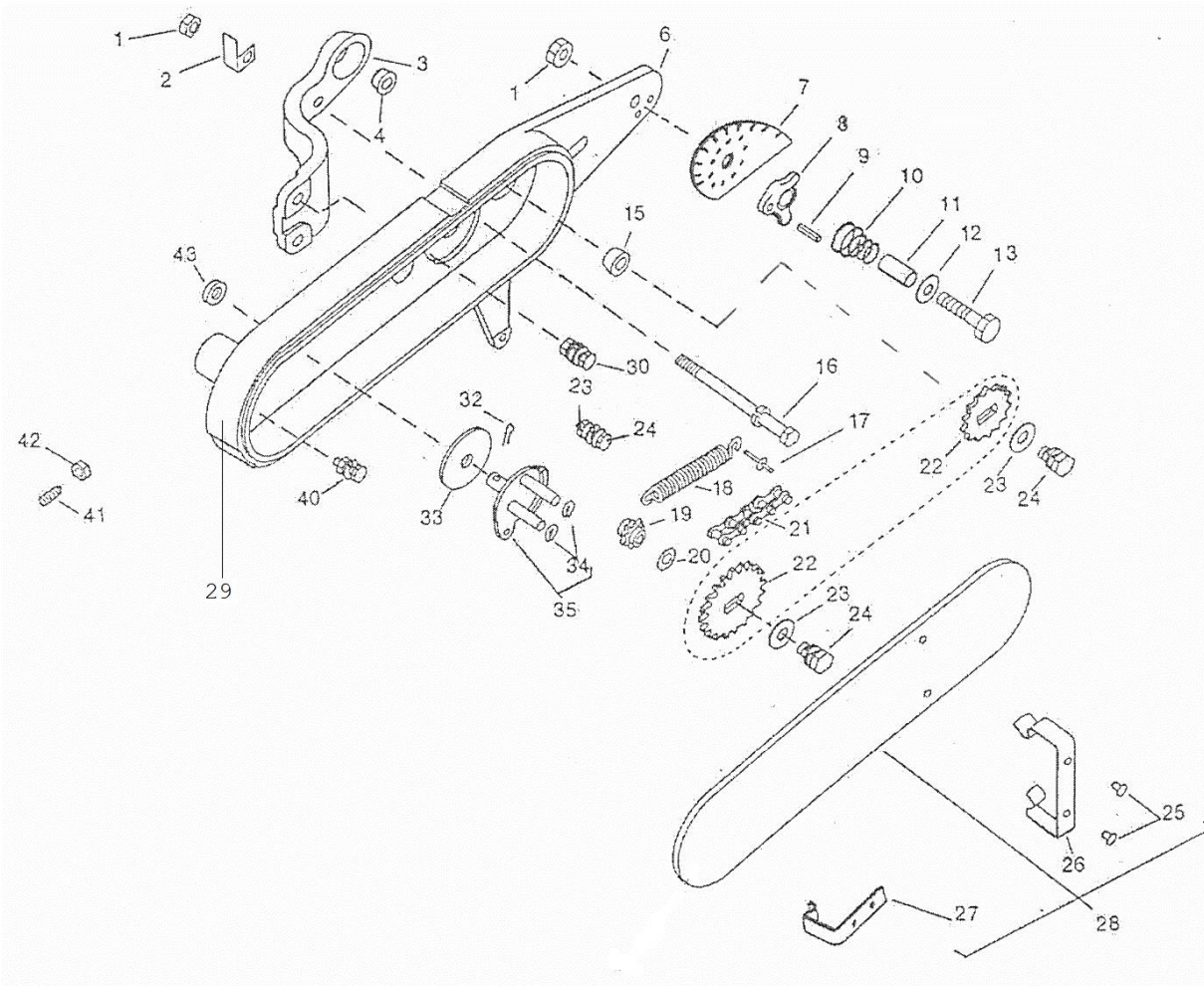

KEY	QTY.	PART NO.	DESCRIPTION
-----	------	----------	-------------

1.	2	6010-311	7/16" JAM NUT ZYD.
2.	1	6010-387	SHIELD
3.	1	6010-373	BRACE
4.	1	6010-371	1-1/8" SLEEVE
6.	1	6010-471	HOUSING
7.	1	6010-354	CAM
8.	1	6010-352	STOP
9.	1	2530-154	1/4 X 1 COTTER PIN ZYD.
10.	1	6010-358	SPRING
11.	1	6010-359	SPACER
12.	1	2526-301	7/16" STD. FLAT WASHER ZYD.
13.	1	6010-314	7/16-14 X 2-1/2" HHCS GR 2 ZYD.
15.	1	6010-372	SLEEVE
16.	1	6010-424	7/16-14 X 5-1/2 HHCS GR 5 ZYD.
	1	2525-301	7/16 MED LOCK WASHER ZYD.
17.	1	6010-383	POP RIVET 3/16 DIA.
18.	1	6010-379	EXTENSION SPRING
19.	2	6010-377	CHAIN SPROCKET, 7 TOOTH
20.	2	2526-253	3/8 SAE FLAT WASHER ZYD.
21.	1	6010-334	LINK CHAIN, TYPE 65, 86 LINKS
22.	1	6010-362	CHAIN SPROCKET, 11 TOOTH
	1	6010-363	CHAIN SPROCKET, 14 TOOTH
	1	6010-364	CHAIN SPROCKET, 20 TOOTH
	1	6010-365	CHAIN SPROCKET, 22 TOOTH

KEY	QTY.	PART NO.	DESCRIPTION
-----	------	----------	-------------

23.	3	2526-352	1/2 SAE FLAT WASHER ZYD.
24.	3	2502-281	7/16-14 X 3/4 HFLHCS GR5 ZYD
	2	2525-301	7/16 MED LOCK WASHER ZYD.
25.	4	6010-400	POP RIVET
26.	1	6010-356	SPRING
27.	1	6010-357	SPRING
28.	1	6010-335	COVER ASSEMBLY
29.		6010-336	HOUSING (INCLUDES #6 & #15)
30.	2	6010-310	7/16-14 X 1-1/2 CARBLT GR5 Z
	2	2525-301	7/16 MED LOCK WASHER ZYD.
	2	2520-303	7/16-14 HEX NUT ZYD.
32.	1	2531-107	1/8 X 1 COTTER PIN ZYD.
33.	1	6010-380	BUSHING
34.	2	6010-410	SNAP RING
35.	1	6010-381	IDLER ASSEMBLY
40.	1	6010-315	7/16-14 X 1-1/2 HHCS GR 5 ZYD
	1	2525-301	7/16 MED LOCK WASHER ZYD.
	2	2526-352	1/2 SAE FLAT WASHERS ZYD.
	1	2520-303	7/16-14 HEX NUT ZYD.
41.	1	6010-320	1/4 X 7/8 SET SCREW
42.	1	2520-151	1/4-20 HEX NUT ZYD
43.	1	6010-378	THRUST WASHER



# PARTS IDENTIFICATION

BAFFLE AND ACID DELINTED COTTON, BEANS,  
REGULAR RATE MAIZE AND CORN

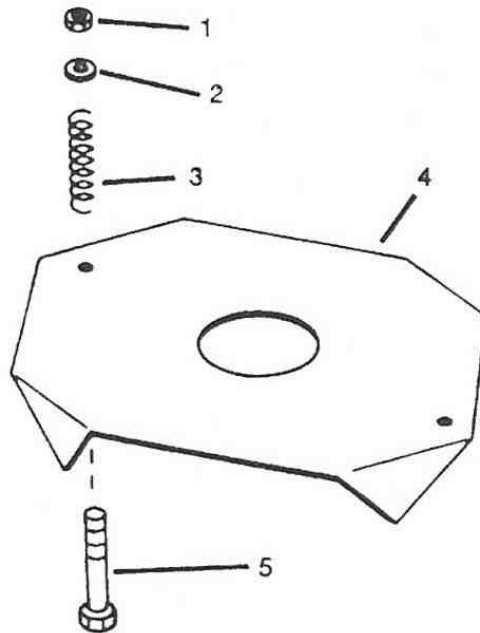

KEY	QTY.	PART NO.	DESCRIPTION
1.	2	6010-406	1/4-20 HEX LOCK NUT ZYD
2.	2	2526-151	1/4 STANDARD FLAT WASHER ZYD
3.	2	6010-413	COMPRESSION SPRING
4.	1	6010-389	PLATE
5.	2	6010-316	1/4-20 X 3-1/4 HHCS GR 2 ZYD

# PARTS IDENTIFICATION

## SPRING, PLUG AND ANCHOR

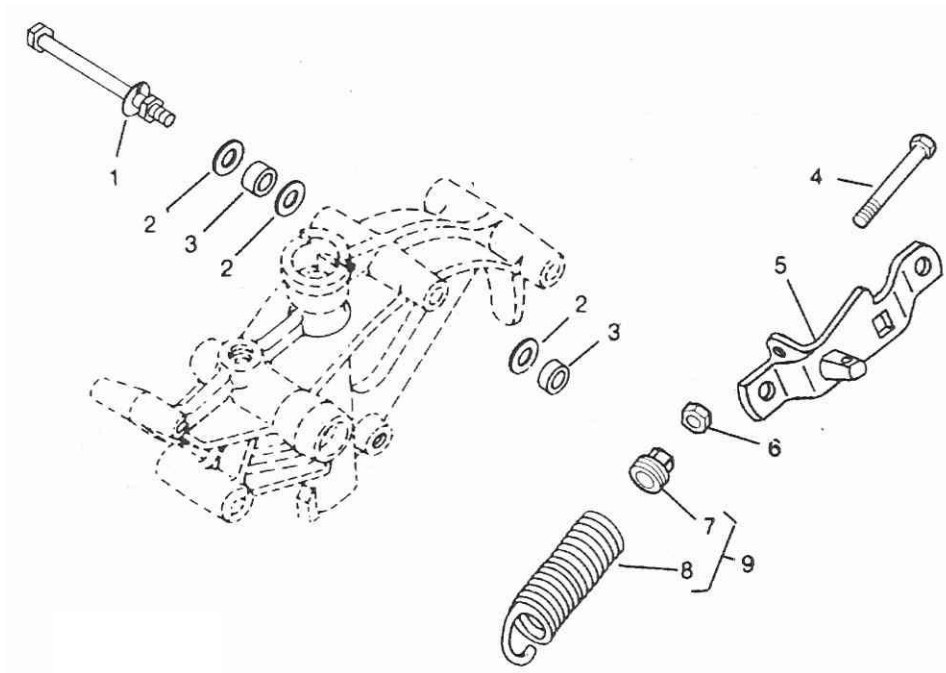

KEY	QTY.	PART NO.	DESCRIPTION
1.	1	2502-372	1/2-13 X 6-1/2" HHCS GR 5 ZYD.
	1	2525-352	1/2 MED LOCK WASHER ZYD.
	1	2520-352	1/2-13 HEX NUT ZYD.
2.	3	6010-396	1/2 HRND FLAT WASHER
3.	2	6010-398	BUSHING
4.	1	6010-313	7/16-14 X 3 HHCS GR 5 ZYD.
5.	1	6010-355	ANCHOR
6.	1	2520-303	7/16-14 HEX NUT ZYD.
7.	1	6010-399	PLUG
8.	1	6010-347	SPRING
9.	1	6010-333	SPRING ASSEMBLY

# PARTS IDENTIFICATION

## SEED BOOT, DISK AND BEARING ASSEMBLY

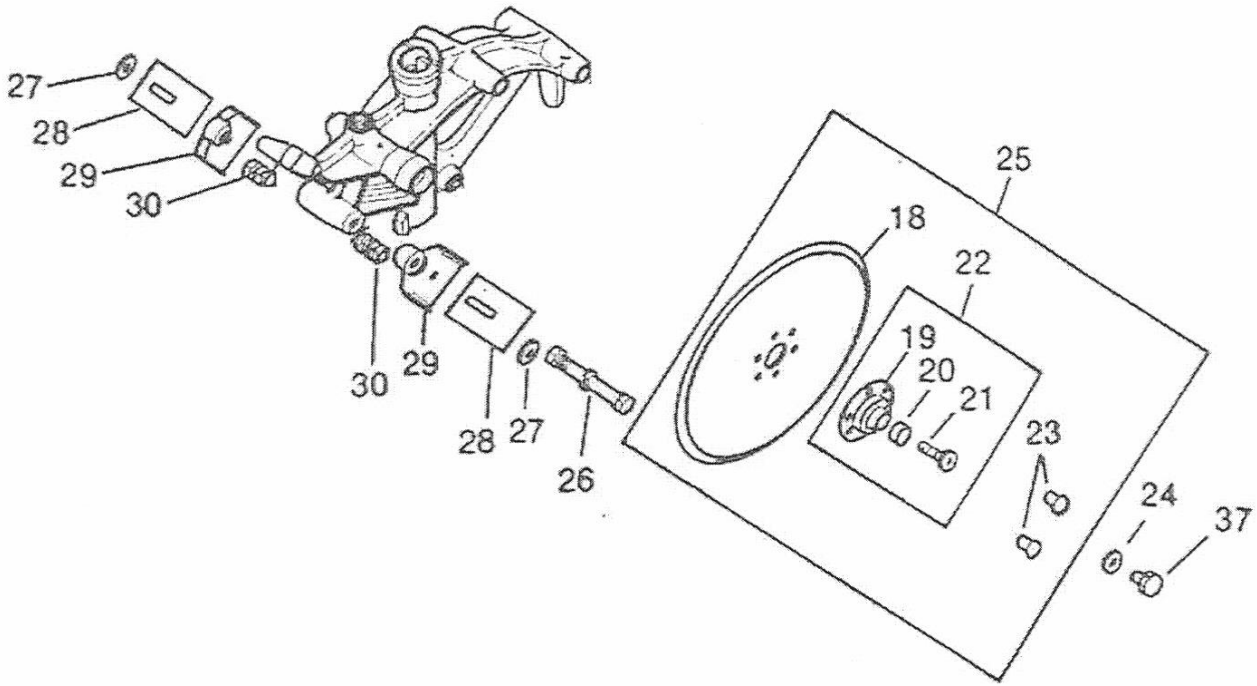

KEY	QTY.	PART NO.	DESCRIPTION
18.	2	6010-395	DISK, 12" X .079"
19.	1	6010-408	CASE
20.	1	6010-346	BALL BEARING
21.	1	6010-404	SCREW, 5/8 X 1, R.H.
	1	6010-405	SCREW, 5/8 X 1, L.H.
22.	1	6010-344	CASE, R.H.
	1	6010-345	CASE, L.H.
23.	12	6010-312	1/4 X 1/2 RIVET
24.	2	6010-321	WASHER, 29/64 X 3/4 X .035
25.	1	6010-339	BLADE, R.H.
	1	6010-340	BLADE, L.H.
26.	1	6010-318	7/16-14 X 4-3/4 HHCS GR 2 ZYD.
	1	2520-303	7/16-14 HEX NUT ZYD.
27.	2	2526-301	7/16 STD FLAT WASHER ZYD.
28.	2	6010-367	SCRAPER
29.	2	6010-411	SUPPORT
30.	2	2502-237	3/8-16 X 1 HHCS GR 5 ZYD.
	2	2525-251	3/8 MED LOCK WASHER ZYD.
	2	2520-251	3/8-16 HEX NUT ZYD.
37.	2	6010-407	DRAIN PLUG

# PARTS IDENTIFICATION

## SEED BOOT AND DRIVE

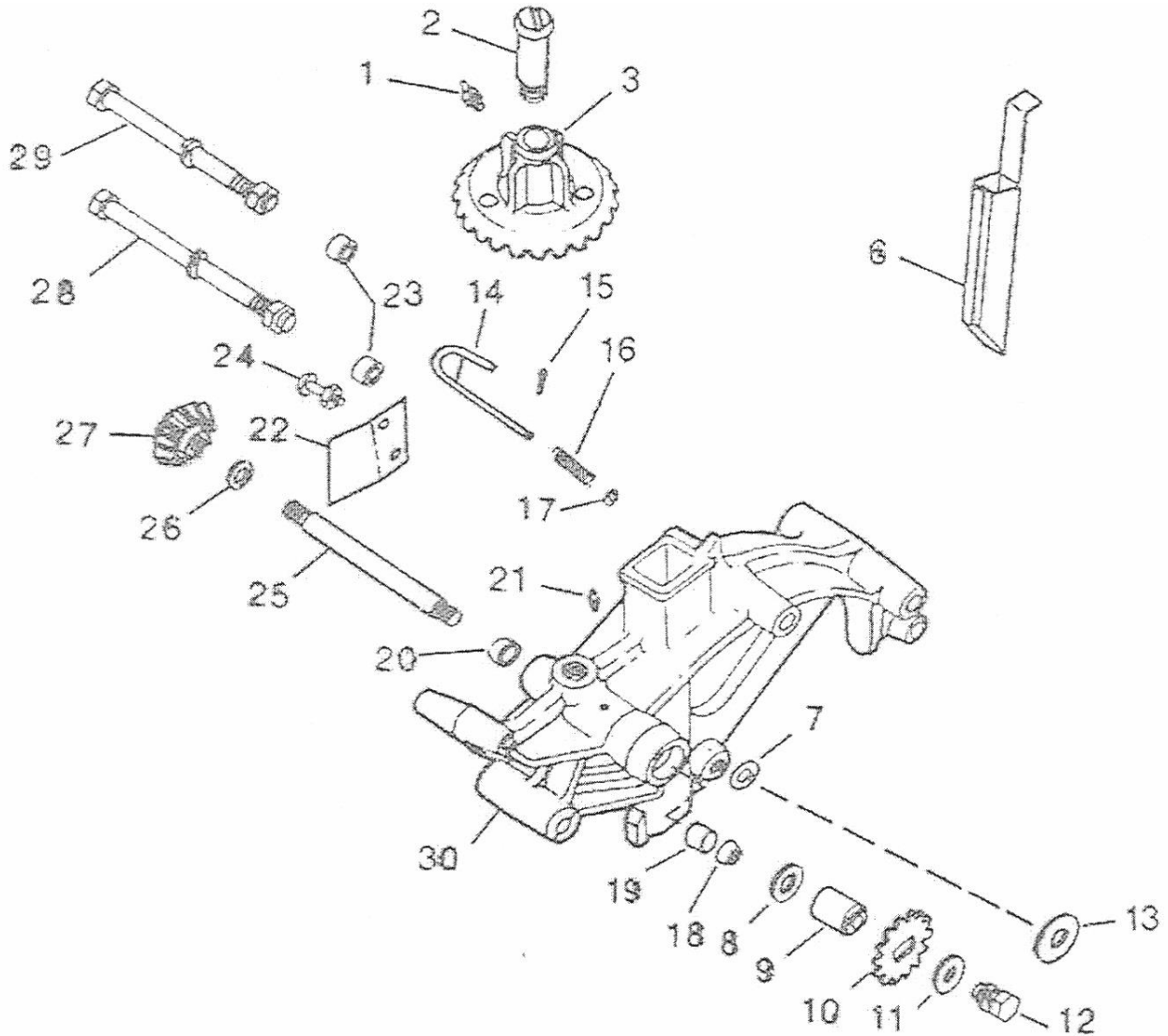

KEY	QTY.	PART NO.	DESCRIPTION
1.	2	2533-110	1/4 STRAIGHT SELF-TAP ZERK
2.	1	6010-388	BOLT
3.	1	6010-350	GEAR
6.	1	6010-337	TUBE (CORN OR PEANUT)
7.	4	6010-323	WASHER, 21/32 X 15/16 X .036
8.	1	6010-384	WASHER, .627 X 1-3/16 X 3/32
9.	1	6010-360	HUB, DRIVEN SPROCKET
10.	1	6010-363	CHAIN SPROCKET, 14 TOOTH
11.	1	2526-352	1/2 SAE FLAT WASHER ZYD.
12.	1	2502-281	7/16-14 x 3/4 HFLHCS GR 5 ZYD
	1	2525-301	7/16 MED LOCK WASHER ZYD.
13.	2	6010-409	SEAL
14.	1	6010-338	LATCH
15.	1	2531-107	1/8 X 1 COTTER PIN ZYD
16.	1	6010-368	SPRING
17.	1	2526-253	3/8 SAE FLAT WASHER ZYD
18.	1	6010-372	SLEEVE, 1-15/32"
19.	1	6010-366	BUSHING
20.	1	6010-371	SLEEVE, 1-1/8"

KEY	QTY.	PART NO.	DESCRIPTION
21.	1	6010-402	1/8 STRAIGHT SELF-TAP ZERK
22.	1	6010-375	SCRAPER, R.H. INSIDE
	1	6010-376	SCRAPER, L.H. INSIDE
23.	4	6010-398	BUSHING
24.	1	2502-293	1/2-13 X 1-1/4 HHCS GR 5 ZYD.
	1	2520-356	1/2-13 HEX JAM NUT ZYD.
25.	1	6010-351	STUD
26.	1	6010-322	WASHER, 33/64 X 7/8 X .048
27.	1	6010-329	RING GEAR AND PINION
28.	1	2502-372	1/2-13 X 6-1/2 HHCS GR 5 ZYD.
	1	2525-352	1/2 MED LOCK WASHER ZYD.
	1	6010-396	WASHER, 17/32 X 1-1/4 X .063
	1	2520-352	1/2-13 HEX LOCK NUT
29.	1	2502-371	1/2-13 X 7 HHCS GR 5 ZYD.
	1	2525-352	1/2 MED LOCK WASHER ZYD.
	1	6010-396	WASHER, 17/32 X 1-1/4 X .063
	1	2520-352	1/2-13 HEX LOCK NUT
30.	1	6010-392	DOUBLE DISK SEED OPENER

# PARTS IDENTIFICATION

## CORN CUTOFF FOR SEED HOPPER

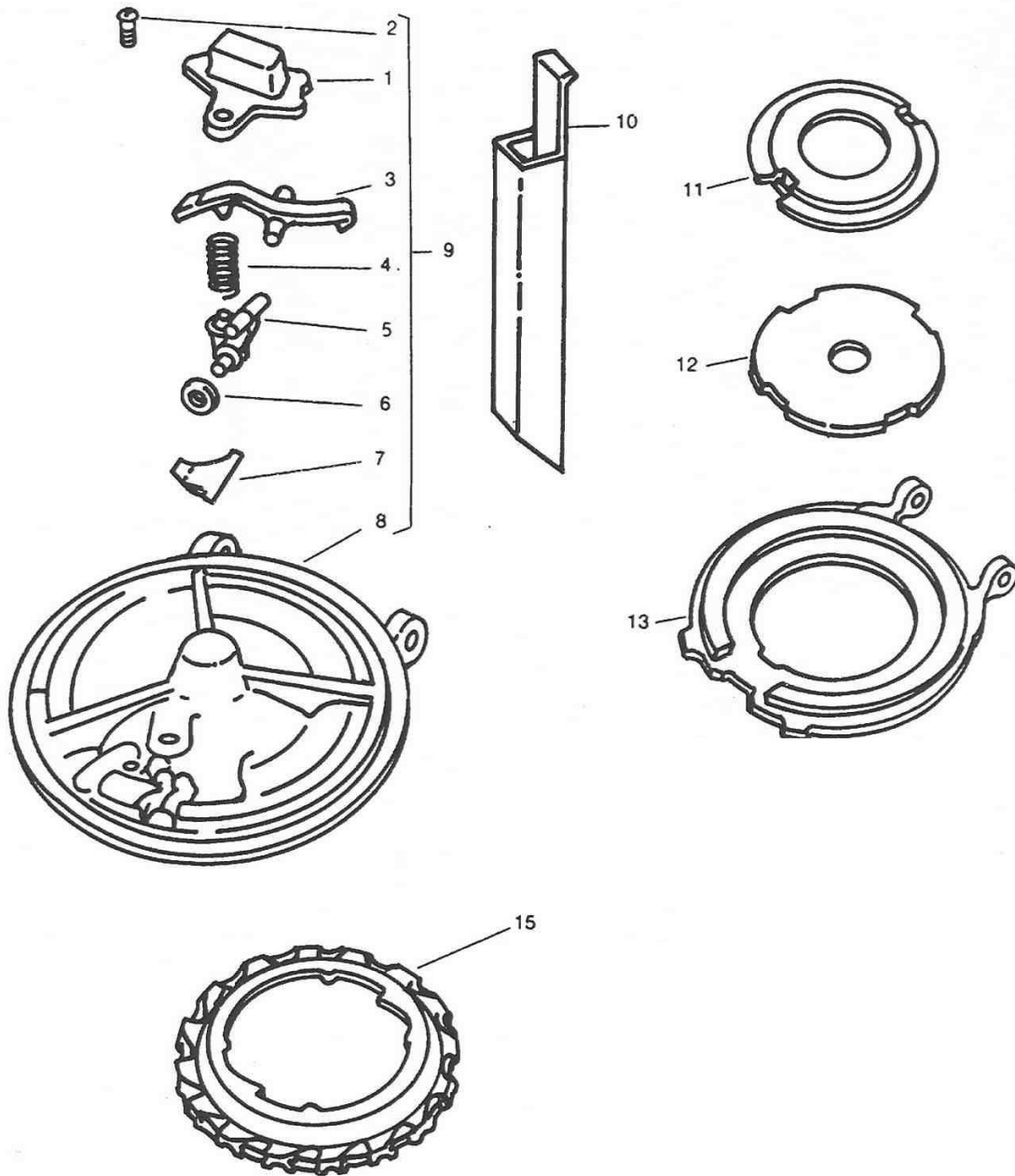

KEY	QTY.	PART NO.	DESCRIPTION
1.	1	6010-328	CAP
2.	1	6010-319	1/4 X 3/4 SCREW
3.	1	6010-326	GATE
4.	1	6010-413	COMPRESSION SPRING
5.	1	6010-327	KNOCKER
6.	1	6010-412	WHEEL
7.	1	6010-348	DEFLECTOR
8.	1	6010-374	BOTTOM, CORN
9.	1	6010-332	PLATE, CORN
10.	1	6010-337	TUBE
11.	1	6010-330	RETAINER
12.	1	6010-361	PLATE
13.	1	6010-331	PLATE, STEEL, FLAT ON BOTH SIDES
15.	1	.....	SEED PLATE (NOT SUPPLIED)

# PARTS IDENTIFICATION

## PRESS WHEEL AND TIRES

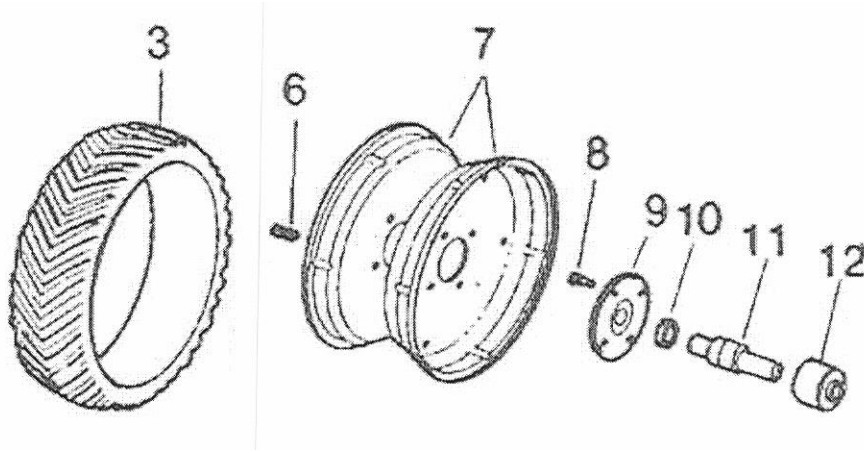

KEY	QTY.	PART NO.	DESCRIPTION
3.	1	6010-385	TIRE, 4 X 16 CHEVRON (SUB FOR N10065)
6.	4	2502-200	5/16-18 X 3/4 HHCS GR 2 ZYD
	4	2520-205	5/16 HEX LOCK NUT ZYD.
7.	2	6010-394	RIM
8.	4	2502-200	5/16-18 X 3/4 HHCS GR 2
	4	2525-201	5/16 MED LOCK WASHER ZYD
9.	1	6010-353	HUB
10.	1	6010-386	WASHER
11.	1	6010-403	BALL BEARING
12.	1	6010-349	HUB

## TROUBLESHOOTING

<u>Problem</u>	<u>Cause</u>	<u>Solution</u>
Inaccurate drop	Wrong seed plate	Select proper seed plate
	Floor plate turned wrong side up or wrong false ring used.	Turn floor plate over or select proper false ring.
	Knocker worn or not working freely	Replace knocker. (Under cut-off cap)
	Chain on wrong sprockets	Refer to charts.
	Planting too fast	Plant slower
Planting more seed in some rows than in others	Cut-off worn	Replace cut-off
	Weak cut-off spring	Replace spring
	Wrong seed plate or false ring in one hopper	Select right seed plate or false ring to match
	Hopper not secured tightly.	Secure with latch.
Too many skips.	Seed hoppers nearly empty	Fill hoppers.
	Obstruction in seed plate	Remove obstruction.
	Excessive speed	Slow down to recommended speed.
Depth adjusting cam does not rest against stop in planting position.	Down pressure spring too tight.	Loosen down pressure spring.
Runners plugging	Planter not running level	Level planter
	Allowing planter to roll backward when lowering	Lower planter only when tractor is moving forward.

# Our name Is getting known

Just a few years ago, Yetter products were sold primarily to the Midwest only. Then we embarked on a program of expansion and moved into the East, the South, the West and now north into Canada. We're even getting orders from as far away as Australia and Africa.

So, when you buy Yetter products . . .you're buying a name that's recognized. A name that's known and respected. A name that's become a part of American agriculture and has become synonymous with quality and satisfaction in the field of conservation tillage.

Thank you.

**YETTER MANUFACTURING CO.**

Colchester, IL 62326-0358 • 309/776-4111

Toll Free 800/447-5777

Fax 309/776-3222

Website: [WWW.YETTERCO.COM](http://WWW.YETTERCO.COM)

E-MAIL: [INFO@YETTERCO.COM](mailto:INFO@YETTERCO.COM)

2565-724\_REV\_H • 06/24