

Yetter

FARM EQUIPMENT

5000 SERIES STALK DEVASTATOR

John Deere Chopping / 20", 22", & 30"

Geringhoff Chopping / 20", 22", & 30"

Case 20" & 22" 2212 / 2412 / 3212 / 3412

New Holland 20" & 22" NH96C / 996 / 98D

Calmer / Lexion & Capello Non-Chopping

OWNER'S MANUAL & PART IDENTIFICATION

2565-965_REV_C • 06/2024



YETTER MANUFACTURING CO.

Founded 1930

Colchester, IL 62326

Toll free: (800)447-5777.

Fax: (309)776-3222

Website: yetterco.com

E-mail: info@yetterco.com

YETTER

TABLE OF CONTENTS

FOREWARD.....	2
WARRANTY.....	2
SAFETY INFORMATION.....	3 – 4
INSTALLATION CHECKLIST / TORQUE.....	5
TOOLS NEEDED.....	6
ASSEMBLY INSTRUCTIONS.....	6 – 13
LOCK UP / OPERATION.....	14
STORAGE / TRANSPORT / MAINTENANCE.....	15
PART IDENTIFICATION.....	16 – 27
TROUBLESHOOTING.....	28

FOREWORD

You've just joined an exclusive but rapidly growing club.

For our part, we want to welcome you to the group and thank you for buying a Yetter product.

We hope your new Yetter products will help you achieve both goals-increase your productivity and increase your efficiency so that you may generate more profit.

This operator's manual has been designed into 4 major sections: Foreword, Safety Precautions, Installation Instructions and Parts Breakdown.



This **SAFETY ALERT SYMBOL** indicates important safety messages in the manual. When you see this symbol, be alert to the possibility of **PERSONAL INJURY &** carefully read the message that follows.

The word **NOTE** is used to convey information that is out of context with the manual text. It contains special information such as specifications, techniques and reference information of a supplementary nature.

The word **IMPORTANT** is used in the text when immediate damage will occur to the machine due to improper technique or operation.

Important will apply to the same information as specified by note only of an immediate and urgent nature.

It is the responsibility of the user to read the operator's manual and comply with the safe and correct operating procedure and to lubricate and maintain the product according to the maintenance schedule in the operator's manual.

The user is responsible for inspecting his machine and for having parts repaired or replaced when continued use of the product would cause damage or excessive wear to the other parts.

It is the user's responsibility to deliver his machine to the Yetter dealer who sold him the product for service or replacement of defective parts, which are covered by the warranty policy.

If you are unable to understand or follow the instructions provided in this publication, consult your local Yetter dealer or contact:

YETTER MANUFACTURING CO.

309/776-4111

800/447-5777

309/776-3222 (FAX)

Website: www.yetterco.com

WARRANTY

Yetter Manufacturing warrants all products manufactured and sold by it against defects in material. This warranty being expressly limited to replacement at the factory of such parts or products as shall appear to be defective after inspection. This warranty does not obligate the Company to bear cost of labor in replacement of parts. It is the policy of the Company to make improvements without incurring obligations to add them to any unit already sold. No warranty is made or authorized to be made, other than herein set forth. This warranty is in effect for one year after purchase.

DEALER: _____

Yetter Manufacturing warrants its own products only and cannot be responsible for damages to equipment on which mounted.

BE ALERT!

YOUR SAFETY IS INVOLVED



WATCH FOR THIS SYMBOL. IT POINTS OUT IMPORTANT SAFETY PRECAUTIONS. IT MEANS “ATTENTION – BE ALERT!”

It is your responsibility as an owner, operator, or supervision to know and instruct everyone using this machine at the time of initial assignment and at least annually thereafter, of the proper operation, precautions, and work hazards which exist in the operation of the machine in accordance with OSHA regulations.

Safety Is No Accident

The following safety instructions, combined with common sense, will save your equipment from needless damage and the operator from unnecessary exposure to personal hazard. Pay special attention to the caution notes in the text. Review this manual at least once a year with all operators.



1. Read and understand the operator's manual before operating this machine. Failure to do so is considered a misuse of the equipment.
2. Make sure equipment is secure before operating.
3. Always keep children away from equipment when operating.
4. Make sure everyone that is not directly involved with the operation is out of the work area before beginning operation.
5. Make sure all safety devices, shields, and guards are in place and functional before beginning operation
6. Shut off all power to adjust, service, or clean.
7. Keep hands, feet, and clothing away from moving parts. It is a good idea to remove all jewelry before operating.
8. Inspect the machine periodically during operation for signs of excessive wear, loose fasteners, and unusual noises.

PLEASE READ, VERY IMPORTANT



SECURE CORN HEADER AGAINST UNWANTED LOWERING BY APPLYING THE LOCKING MECHANISM ON THE HYDRAULIC CYLINDERS!



- 1. Attach head to combine, lock head to combine**
- 2. Raise the head off the ground and engage safety stop on the feeder house cylinder.**
- 3. Turn off combine engine and remove the key**

Subject to the size and weight of the corn header, one or two additional hydraulic cylinders may be required.

The combine manufacturer generally keeps corresponding kits readily available for dealers.

Subject to the design of the corn header and the carrying capacity of different combines, the steering axle may require the fitting of additional weights and the rear tires be filled with ballast.

FOLLOW ALL INSTRUCTIONS GIVEN BY THE COMBINE MANUFACTURER

DEVASTATOR OPERATION CHECKLIST

Please fill this out after the Yetter Stalk Devastator has been installed.

DATE ___/___/___ YETTER KIT # - 5000-___ CORN HEAD MAKE/MODEL_____

COMBINE MAKE/MODEL_____ FRONT TIRE SIZE_____ REAR TIRE SIZE_____

REAR AXLE POSITION_____ SNAPPING ROLLS USING_____ CHOPPING BLADES YES / NO

DECK PLATE ANGLE____° (USE ANGLE FINDER) SNAPPING ROLL HEIGHT (OPERATING POSITION)____INCHES

HARVEST SPEED_____MPH HEAD SPEED_____ ANGLE TORSION ARM (OPERATING POSITION - USE ANGLE FINDER)_____

HEAD CART INFO:

MAKE/MODEL_____ LENGTH_____ TIRE SIZE_____

SEE PAGE 14-15 FOR CORN HEAD & TRAILER ADJUSTMENTS

BOLT TORQUE





Important: Over-tightening hardware can cause just as much damage as under-tightening. Tightening hardware beyond the recommended range can reduce its shock load capacity.





All hardware on the 5000 Devastator is either Grade 5 or Grade 8, unless otherwise noted. Grade 5 cap screws are marked with three radial lines on the head. Grade 8 cap screws are marked with six radial lines on the head. If hardware must be replaced, be sure to replace it with hardware of equal size, strength and thread type. Refer to the torque values chart when tightening hardware.

The chart below is a guide for proper torque. Use it unless a specified torque is called out elsewhere in the manual. Torque is the force applied to the end of the handle or cheater bar, times the length of the handle or bar.

Use a torque wrench wherever possible

The following table shows torque in ft.-lbs. for coarse thread hardware.

Bolt Diameter and Threads per Inch	 Grade 2	 Grade 5	 A-325	 Grade 8
1/4	6	10		14
5/16	12	20		30
3/8 - 16	25	35		50
7/16 - 14	35	55		80
1/2 - 13	55	85		125
9/16 - 12	75	125		175
5/8 - 11	105	170		235
3/4-10	185	305		425
7/8 - 9	170	445		690
1-8	260	670		1030
1 1/8 - 7	365	900		1460
1 1/4 - 7	515	1275		2060
1 3/8 - 6	675	1675		2700
1 1/2 - 6	900	2150		3500
1 3/4 - 5	1410	3500		5600

Bolt Diameter	 4.6	 8.8	 10.9	 12.9
	4.6	8.8	10.9	12.9
M4	0.9	2.3	3.2	3.8
M5	1.8	4.5	6.5	7.6
M6	3.0	7.7	11.1	13.0
M7	5.0	13.0	18.5	21.7
M8	7.3	18.8	26.9	31.4
M10	14.4	37.2	53.2	62.2
M12	25.2	64.9	92.8	108.5
M14	40.2	103.7	148.4	173.4
M16	62	161	230	269
M18	86	222	318	372
M20	122	314	449	525
M22	166	428	613	716
M24	211	543	777	908
M27	309	796	1139	1331

INSTALLATION TOOLS REQUIRED:

Electric or Pneumatic Impact,
Torque wrench, 24MM socket,
1 1/8" Socket & wrench,
15/16 socket & wrench, (only used on 5000-070)
3/4" Socket & wrench



5000-070 ASSEMBLY INSTRUCTIONS

JD 40/90 SERIES – CALMER

NOTE: SUPPORT THE FRONT OF THE ROW UNIT BEFORE LOOSENING ANY MOUNTING HARDWARE.
DIFFERENT MOUNT LOCATIONS MAY BE NECESSARY IF CLEARANCE ISSUES ARE FOUND.

Step 1: Remove mounting hardware for each gear box where the Yetter torsion pivot assembly will be mounted. Install 5000-284 Calmer Adaptor Bracket on bottom side of frame sliding the threaded rod through each hole of the straps on the front of the frame & hand thread the 2502-397 5/8 – 11 X 5 1/2 bolts with original lock washer into the gear box. Slide the holes in the upright tab on the 5000-285 over the threaded rod of the 5000-284 & hand tighten new lock washers & hex nuts.

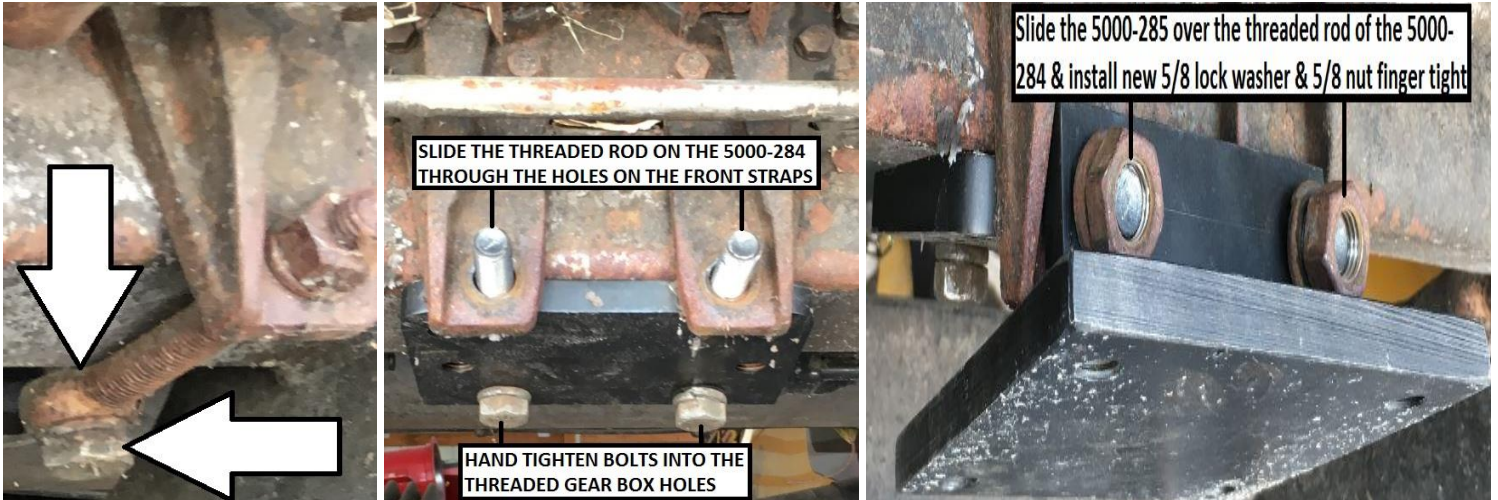

Step 2: Place the 5000-187 locking torsion assembly on the 5000-285 adaptor aligning all 4 holes. Thread by hand the 2502-810 M16 X 2 X 30 bolts on the front set of holes. Place the spacer between the 5000-284 calmer adaptor bracket & the 5000-285 adaptor. Thread by hand the 2502-809 M16 X 2 65 bolts. Tighten the hardware from steps 1 & 2 to torque spec in the following order: A – 1st, B – 2nd, C – 3rd, D – 4th.

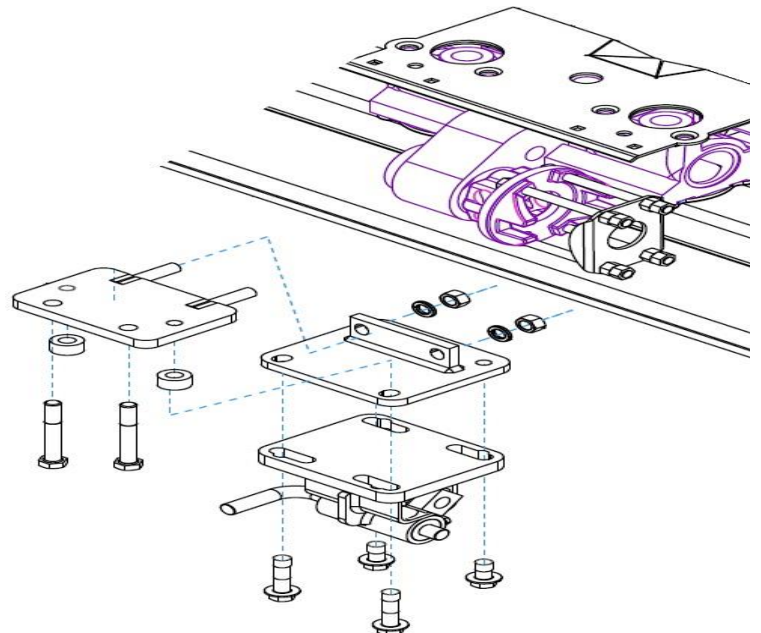
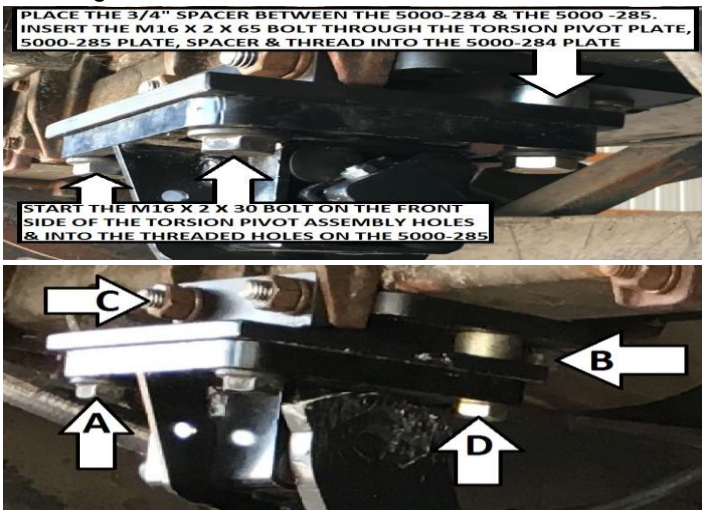

5000-071 ASSEMBLY INSTRUCTIONS

LEXION – CAPELLO

NOTE: SUPPORT THE FRONT OF THE ROW UNIT BEFORE LOOSENING ANY MOUNTING HARDWARE. DIFFERENT MOUNT LOCATIONS MAY BE NECESSARY IF CLEARANCE ISSUES ARE FOUND.

Step 1: Remove the mounting hardware & strap for each gear box where the Yetter torsion pivot assembly will be mounted. Install the 5000-452 Lexion adaptor bracket on the bottom side of the frame using 4) 2502-813 M16 X 2 X 70 8.8 bolts, the original flat washers & spacer bushing. Thread bolts by hand, then tighten to torque spec. (4th bolt not shown in photo)

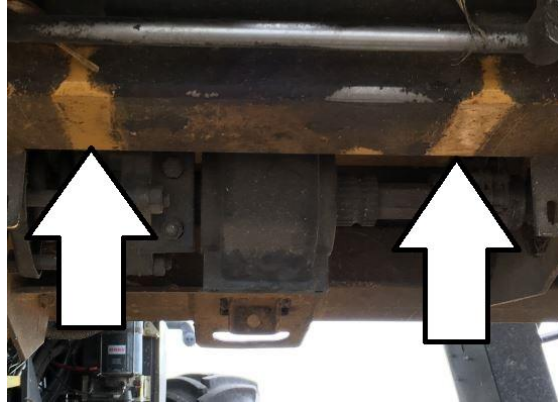

Step 2: Place the 5000-187 locking torsion assembly on the 5000-452 adaptor aligning all 4 holes. Thread the 2502-810 M16 X 2 X 30 bolts by hand, and then tighten to torque spec.

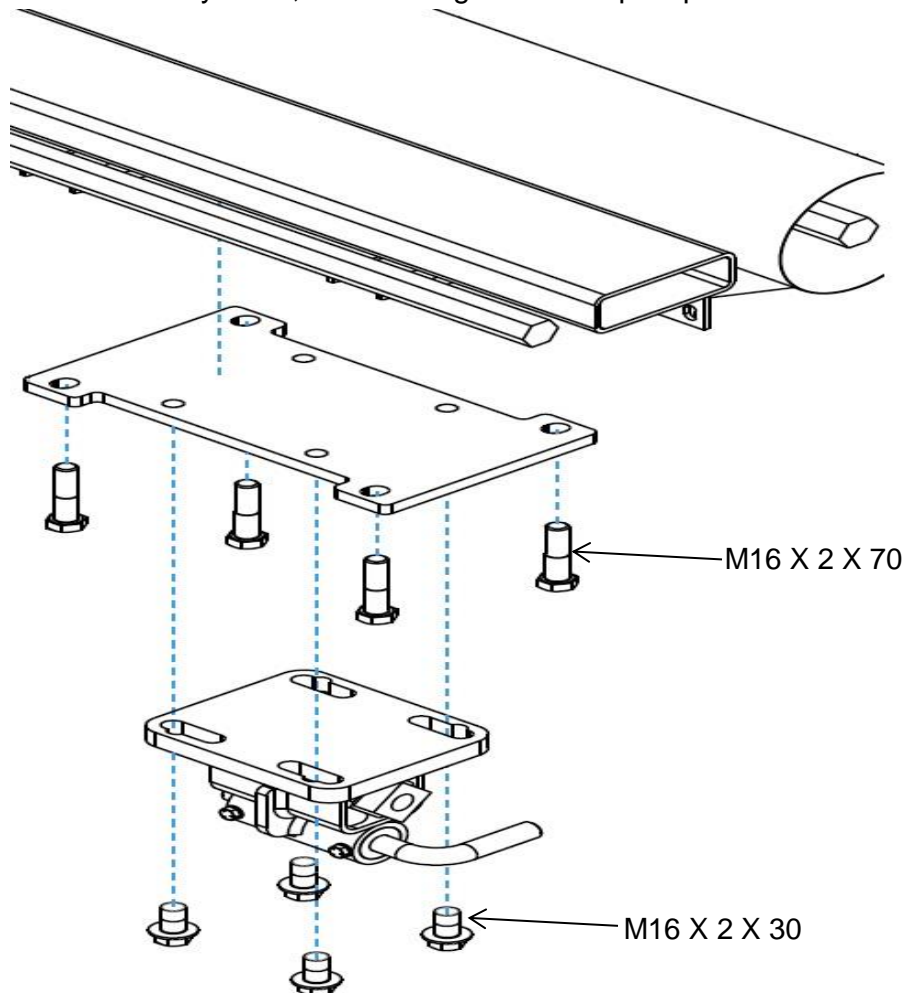

5000-072 ASSEMBLY INSTRUCTIONS

GERINGHOFF

NOTE: GEAR BOXES MUST BE USED TO MOUNT TORSION PIVOTS. SUPPORT THE FRONT OF ROW UNIT BEFORE LOOSENING ANY MOUNTING HARDWARE. DIFFERENT MOUNT LOCATIONS MAY BE NECESSARY IF CLEARANCE ISSUES ARE FOUND.

Step 1: Place the 2) 5000-454 Spacers (longer, used on non-Horizon Geringhoff corn heads) OR 2) 5000-472 Spacers (shorter, used on Horizon Geringhoff corn heads) in the 5000-453 Geringhoff Adaptor Plate. Put the spacers against the bottom side of the corn head frame. (this is to space the adaptor plate away from the weldments & gear box mounting straps) Insert 1) 2502-815 M16 X 140MM through the front side of the adaptor plate on the end that the pivot assembly is not attached to. Insert 1) 2502-814 M16 X 160MM through the back side of the adaptor plate on the end that the pivot assembly is not attached to. Align these 2 bolts with threaded holes on the gear box & thread by hand.

Step 2: Place the 5000-174 torsion pivot assembly on the 5000-285 adaptor aligning 2 slotted holes with the tapped holes on the adaptor bracket & 2 slotted holes that align with the threaded holes on the gear box. Thread the 2) 2502-810 M16 X 2 X 30 bolts by hand into the tapped holes on the adaptor bracket. Thread 1) 2502-814 M16 X 160 on the front side & 1) 2502-817 M16 X 180 on the back side into the gear boxes by hand. Tighten all mounting hardware to torque spec at this time. Below is a diagram showing what holes on the 5000-174 torsion pivot used on Geringhoff corn heads match with the holes in the 5000-285 adaptor plate.

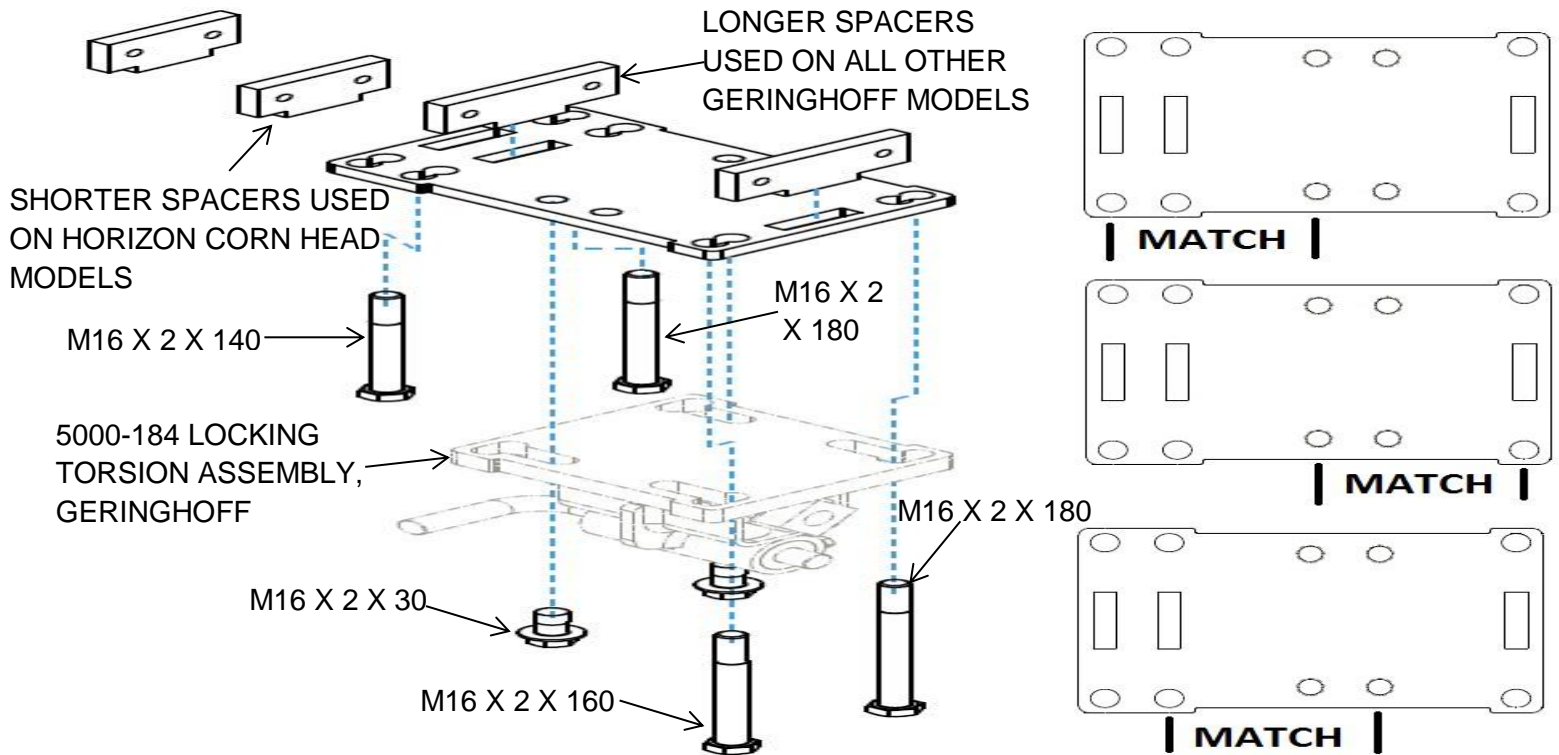

NO GEAR BOX MOUNTING BOLTS REMOVED



1 SET OF GEAR BOX MOUNTING BOLTS REMOVED

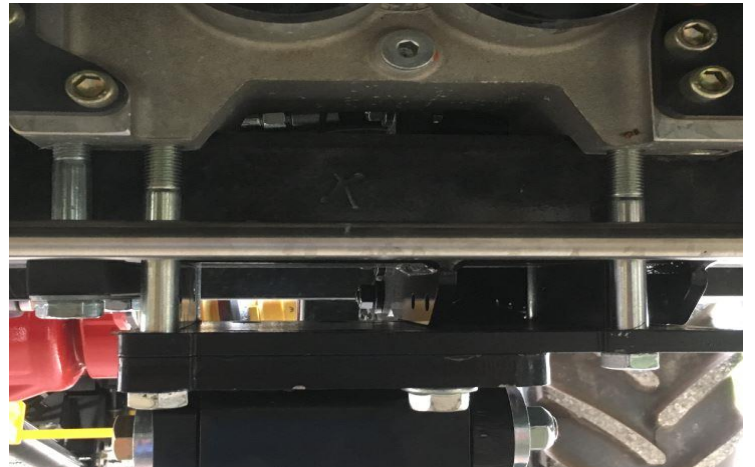

ASSEMBLY INSTRUCTIONS

RECOMMENDED LOCATIONS OF TORSION PIVOT ASSEMBLY BELOW, ALTERNATE LOCATIONS MAY BE USED IF INTERFERENCE OCCURS!

5000-040C & 5000-040A-GER 6 ROW 30"

Arrows indicate 5000-187/5000-184 Torsion Pivot locations – Geringhoff models must use a gearbox

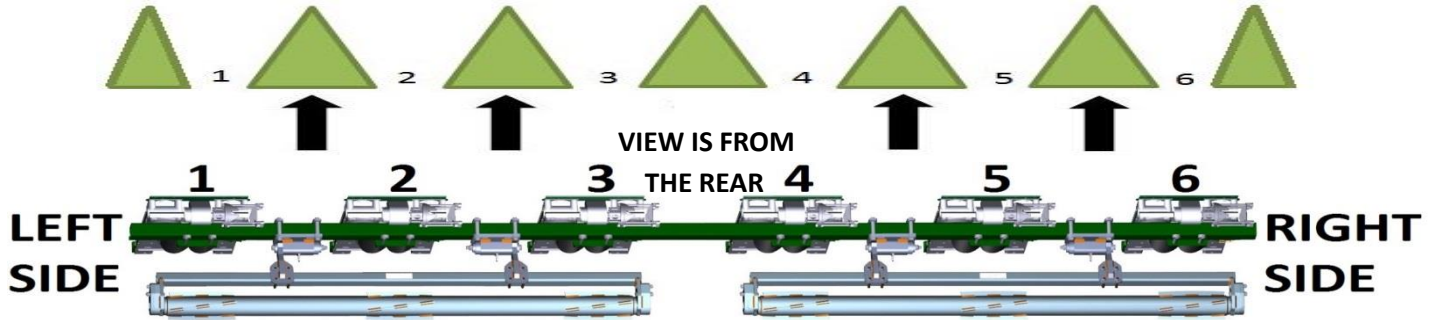

5000-041C & 5000-041A-GER 8 ROW 30"

Arrows indicate 5000-187/5000-184 Torsion Pivot locations – Geringhoff models must use a gearbox

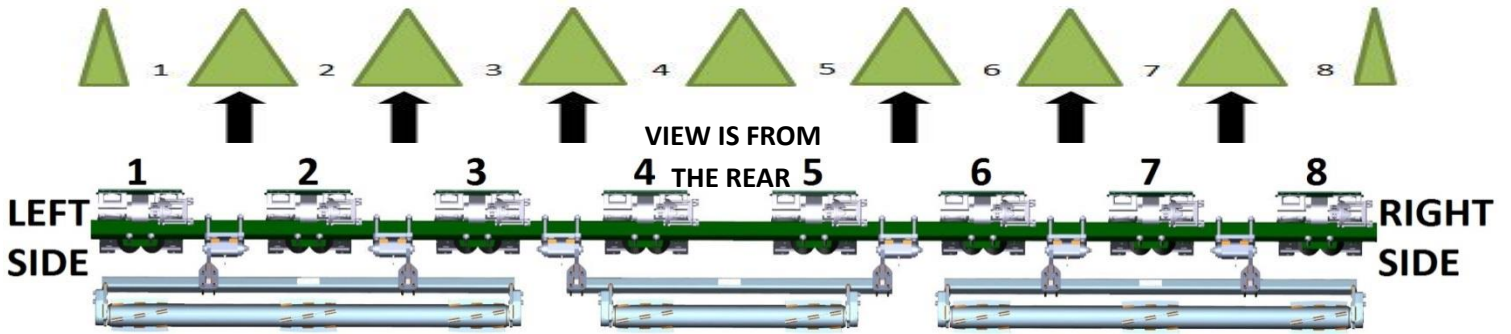

5000-042C, 5000-042B-CNH, & 5000-042A-GER 12 ROW 20"

Arrows indicate 5000-187/5000-184 Torsion Pivot locations – CNH & Geringhoff models must use a gearbox

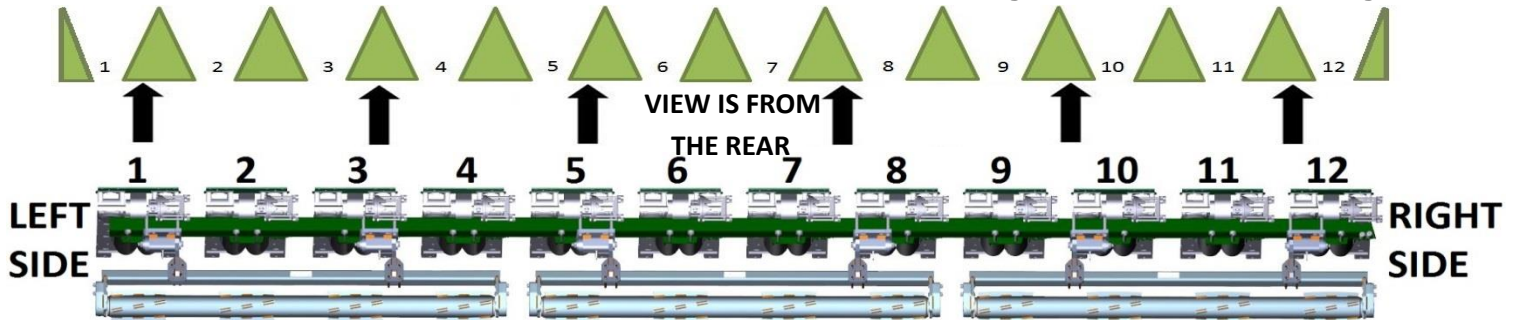

5000-044C & 5000-044A-GER 12 ROW 30"

Arrows indicate 5000-187/5000-184 Torsion Pivot locations – Geringhoff models must use a gearbox

On Rows 3 and 10, 1 set of M16 Bolts will thread into the gear box

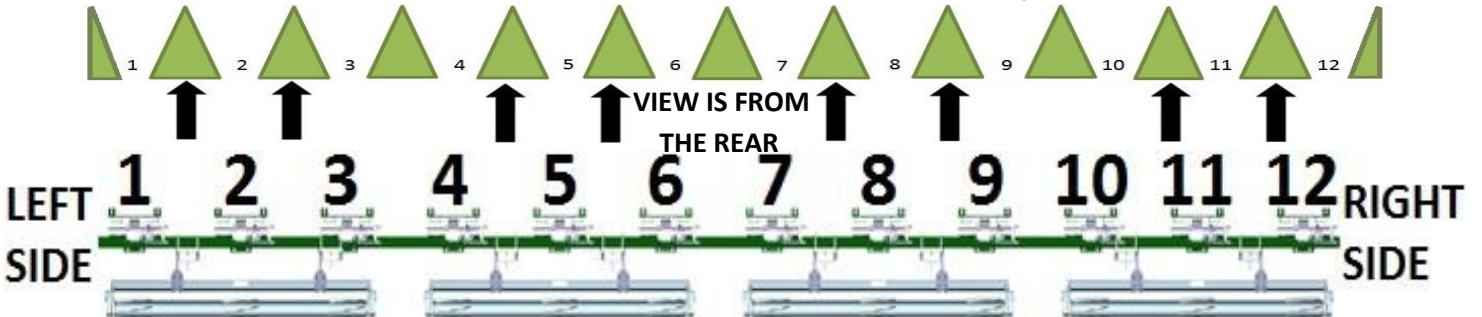

ASSEMBLY INSTRUCTIONS

BELOW ARE RECOMMENDED LOCATIONS OF THE TORSION PIVOT ASSEMBLY, ALTERNATE LOCATIONS MAY BE USED IF INTERFERENCE OCCURS!

5000-045C & 5000-045A-GER 18 ROW 20"

Arrows indicate 5000-187/5000-184 Torsion Pivot locations – Geringhoff models must use a gearbox

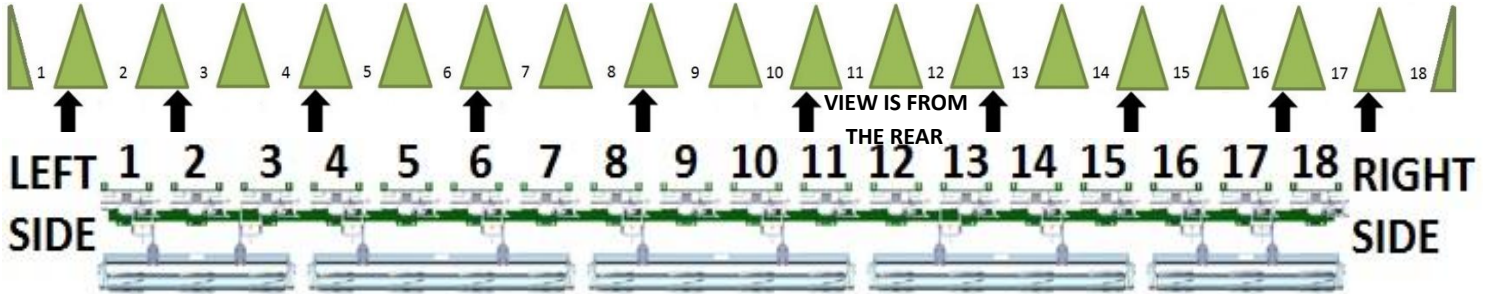

5000-046C, 5000-046B-CNH, & 5000-046A-GER 12 ROW 22"

Arrows indicate 5000-187/5000-184 Torsion Pivot locations – CNH & Geringhoff models must use a gearbox

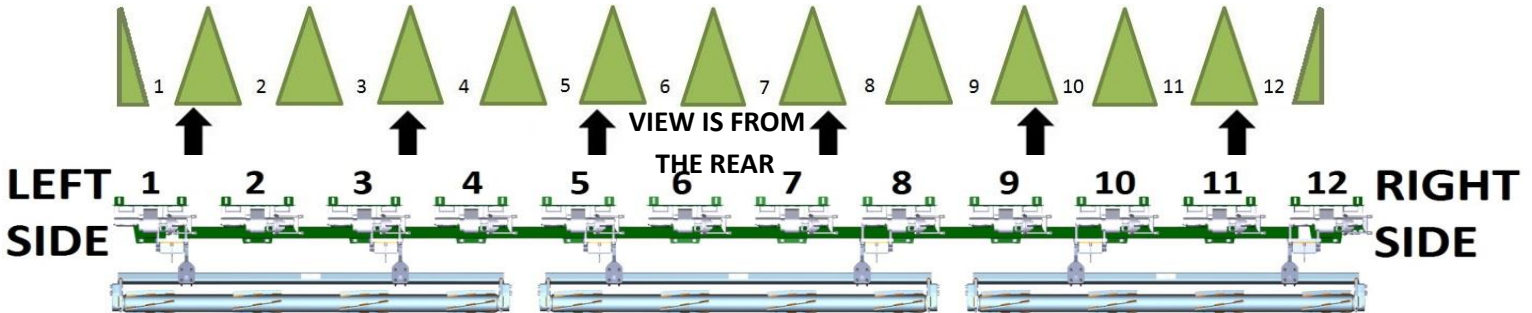

5000-047C & 5000-047A-GER 18 ROW 22"

Arrows indicate 5000-187/5000-184 Torsion Pivot locations – Geringhoff models must use a gearbox

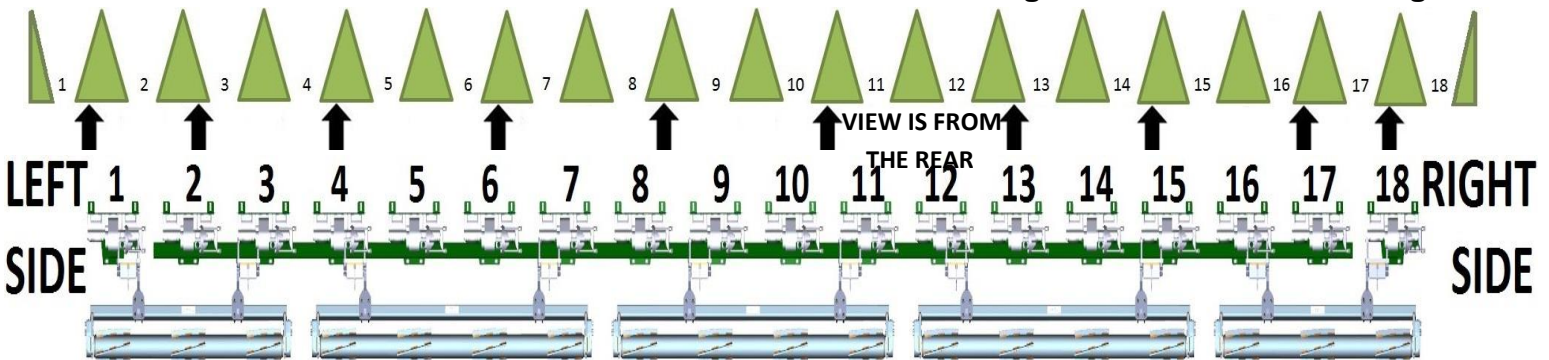

5000-048 JD 8R30" FOLDING

Arrows indicate 5000-187 Torsion Pivot locations – Most mount brackets must use a gearbox

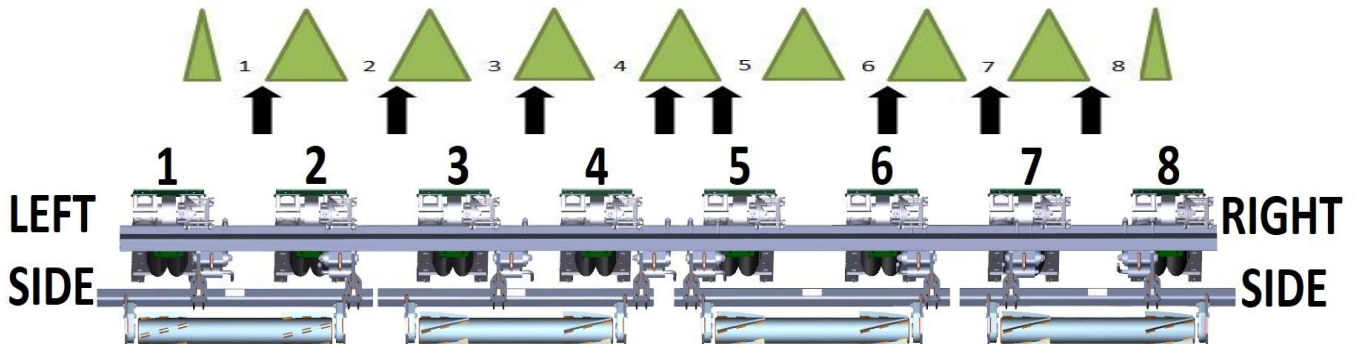

ASSEMBLY INSTRUCTIONS – CASE & NEW HOLLAND

Step 1: Attach the 5000-187 torsion mount bracket to the frame using 2) ½ X 4 ½" bolts w/ torque patch & 2) 9/16ID X 1 ¾OD X ¼ thick washers on the front side & 2) ½ X 6 ½ bolts with torque patch & 2) 9/16ID X 1 ¾OD X ¼ thick washers on the back side. Thread bolts into the gear boxes by hand & tighten with impact wrench & ¾ socket.

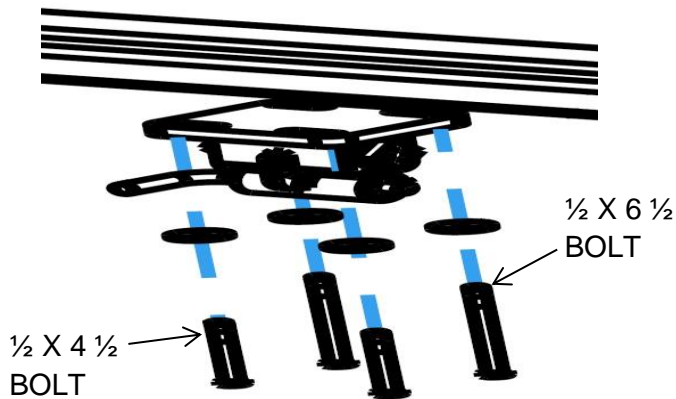

ASSEMBLY INSTRUCTIONS – JOHN DEERE

Step 1: Attach the 5000-187 torsion mount bracket to the frame using 4) M16 X 110 flange head bolts & 2) 5000-420 clamp straps. Thread bolts into the clamp straps by hand & tighten to torque specifications. **Note: Torque the M16 bolts @ 236 ft. /lbs.**

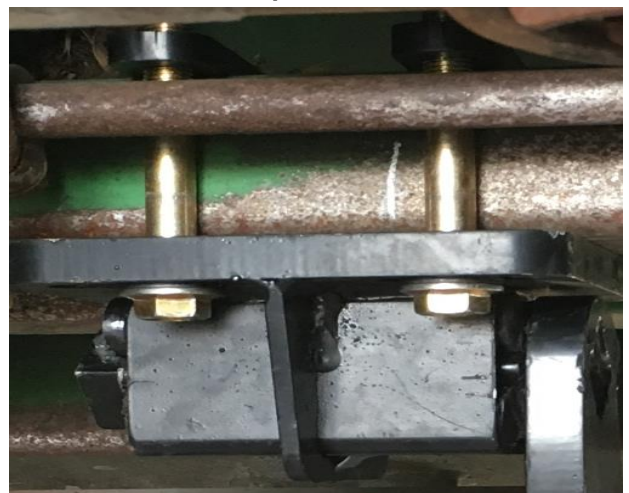
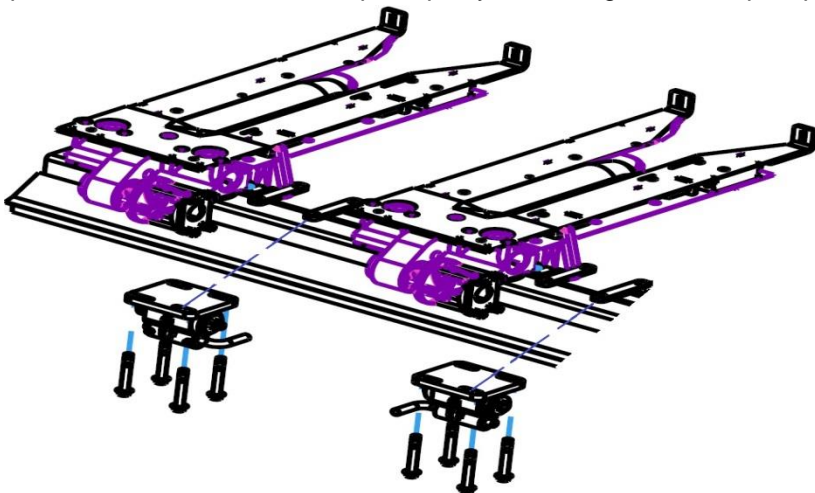

Alternative Step 1: (20"-22" row spacing) Remove (1) toolbar strap from gear box, then attach the 5000-168 torsion mount brackets to frame & gear box using 2) M16 X 120 flange head bolts & (1) 5000-420 clamp & 2) M16 X 110 flange head bolts. Some situations may require 1 side of the gear box to install a mounting bracket. Mounting locations may vary. The photo below on the left illustrates the gear box bolt & clamp that need removed. The photo below on the right illustrates: **Arrow A** – Using 1 side of gear box to mount 5000-158 torsion mount bracket using 2) M16 X 120 flange head bolts. **Arrow B** – Using 1) 5000-420 clamp & 2) M16 X 110 flange head bolts. **Note: Torque M16 bolts @ 236 ft./lbs.**

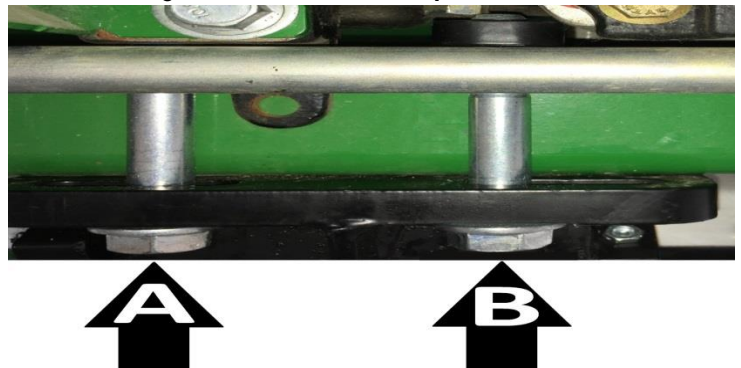
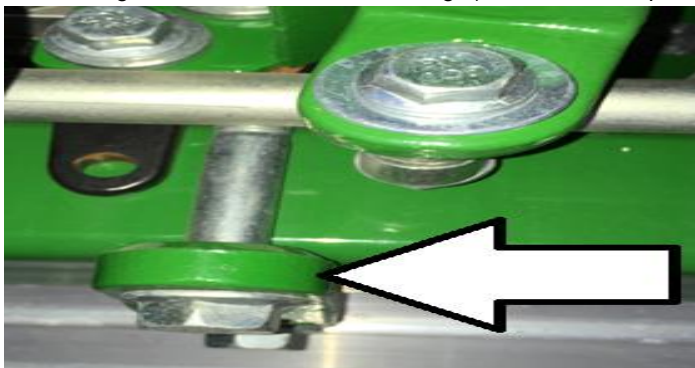

NOTE: Each roller has 2 Locking Torsion Assemblies & it is best to have the 2 Lock Handles facing each other (for easier accessibility) **UNLESS** that puts the handle directly under the snapping rolls. In this case, flip the Locking Torsion Assembly around to keep the handle between the rows.

ASSEMBLY INSTRUCTIONS

Step 2: Install the 5000-292 Torsion Arm onto the Locking Torsion Assembly & secure with $\frac{3}{4}$ " x 8" bolts & $\frac{3}{4}$ " lock nuts.

NOTE: Torsion Assemblies shown with handle in locked up position. Turn handle vertical for this assembly process.

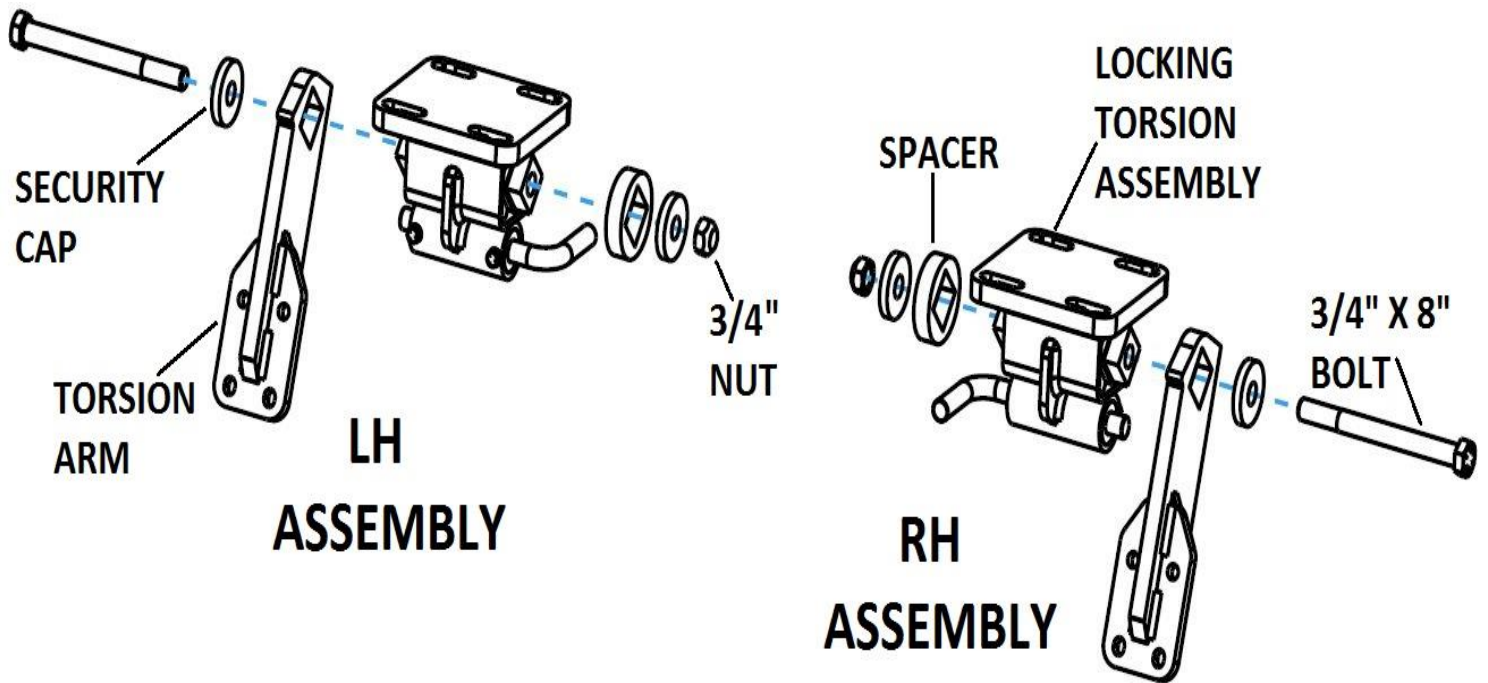

Step 3: Attach the roller mount to pivot arms using $\frac{1}{2}$ " x 2-1/2" x 3-1/2" U-bolts & lock nuts. **DO NOT** tighten U-bolts until the roller & bearing are mounted.

NOTE: The bearing support tab on the roller mount tube should be on the backside of the bearing mount plate.

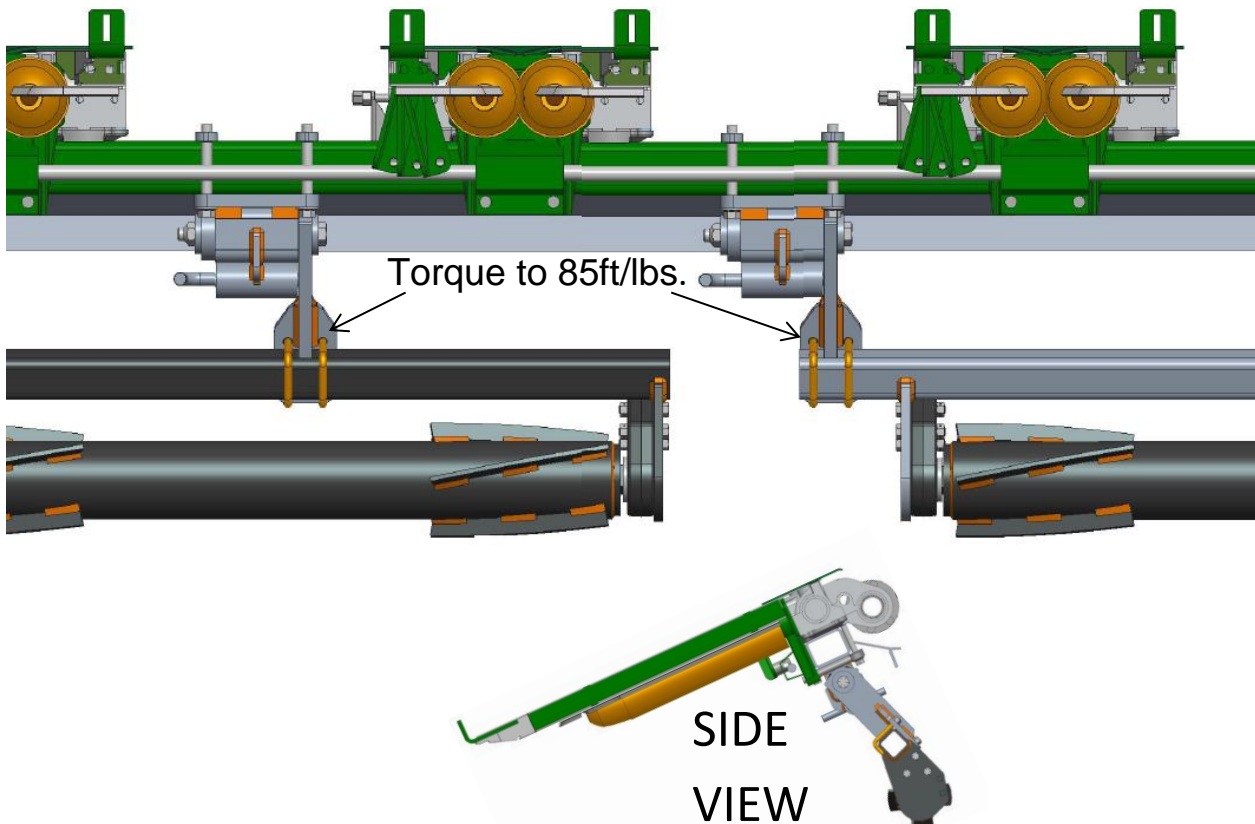

ASSEMBLY INSTRUCTIONS

Step 4: Insert the shim washer over the shaft on each end of the roller. Install the bearing over the shaft on each end of the roller so that the side of the casting that has the bearing protruding past the housing surface is towards the roller barrel & shim washer. Lift each roller into place so that the bolt holes on the cast line up with the mounting tabs on the roller arm mount tube. Install the 1/2" X 2 1/2" bolts and tighten the 1/2" lock nuts. Once the roller & bearing hardware is fastened, spin the roller to ensure the bearing was installed correctly. If the roller was installed incorrectly, the roller will not spin or will have drag. Slide the roller mount tube to gain clearance on each end of the corn head, center the traction bar under the row as much as possible, & then tighten the hardware from **Step 3**. In some circumstances, the traction bar may have to be off-center of the row some.

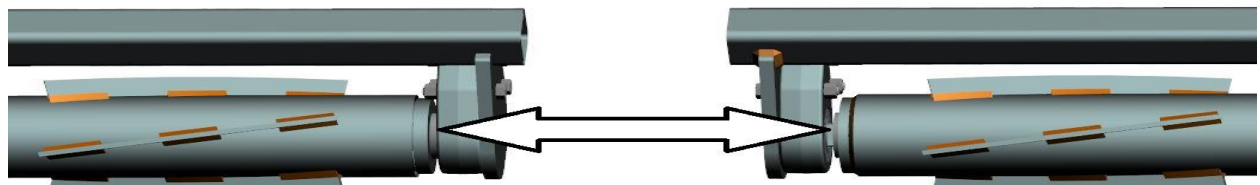
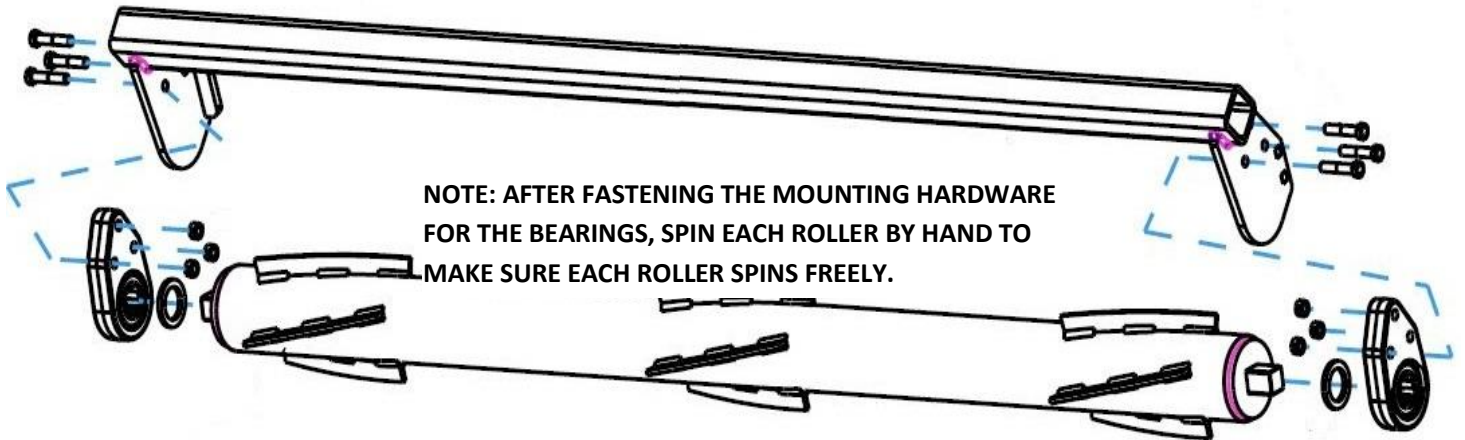

NOTE: WOBBLE BEARING HOUSING SHOULD BE LUBRICATED WITH POLYUREA GREASE BEFORE USE AND THEN EVERY 100 HOURS OF OPERATION

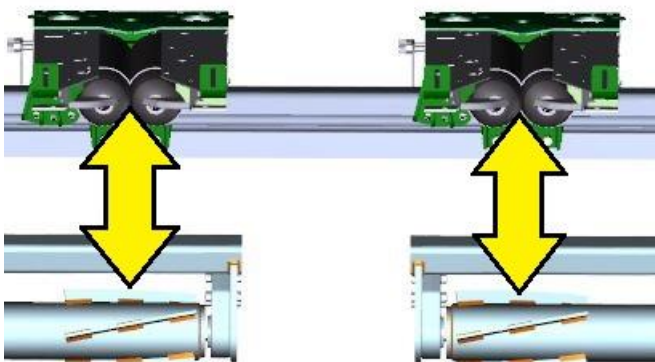

Step 5: (If Applicable) On chopping corn heads, trim 3 inches off the bottom of the back curtain to keep roller from contacting curtain & allow better residue flow. The center divider curtain will also have to be trimmed for clearance.

NOTE: Make sure the chopping blades are sharp enough to size the residue into smaller pieces for better flow between the back curtain & roller mount tube.

LOCK UP

To "lock up" Devastator rollers, lower head down & rotate the locking handle 90 degrees. If the handle is vertical, the devastator will be in operation mode. If the handle is horizontal & is in front of the pivot arm (see yellow circle below), the devastator is locked up. On torsion style devastators without the lock up feature, a 5000-430 Lock Pin can be ordered separately to lock up devastator rollers. 6 row heads require 1 lock pin, 8/12 row heads require 2, 18 row heads require 3.

Operating Position

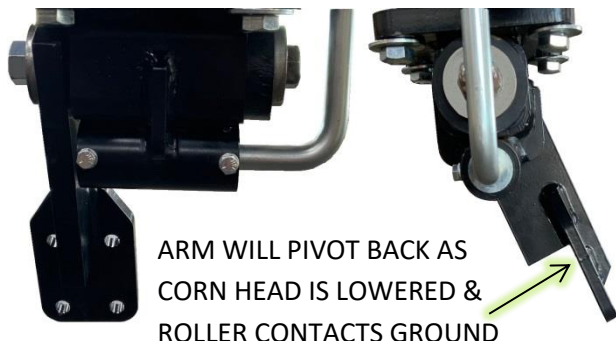

Locked Up Position



OPERATION

CORN HEAD ANGLE NEEDS TO BE ADJUSTED BETWEEN 22 – 25° FOR OPTIMUM DEVASTATOR PERFORMANCE.

USE THE 5000-455 TO CHECK CORN HEAD ANGLE:

- Put the combine on a level surface. Lower the Corn head to your normal working head height.
- Place the magnetic protractor on the stripper plate to get the angle. Adjust the feeder house as needed, fore or aft, to achieve 22 – 25 degrees.
- Adjust the snouts to raise/lower head to preferred head height.

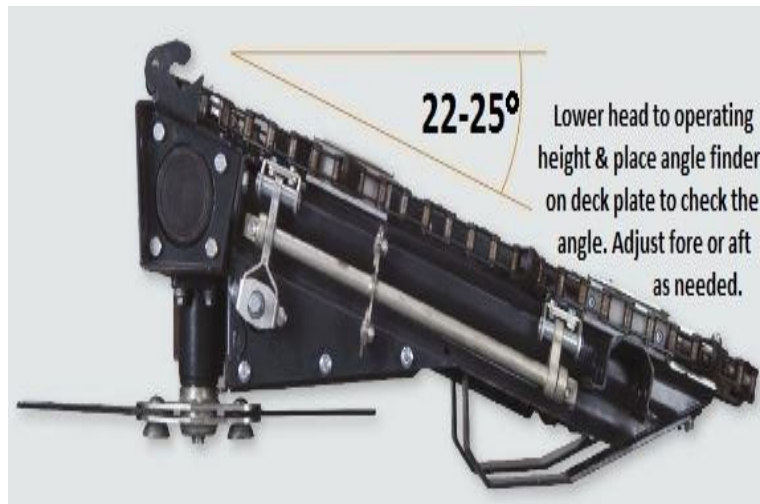

1. Raise point (A) and lock latch (B).
2. Pull spring locking pin (C) and adjust height using location holes (D).
3. The points can be fine adjusted by loosening jam nut (E) and adjusting cap screw (F) up or down.

- A-Point
- B-Latch
- C-Locking Pin
- D-Location Hole
- E-Jam Nut
- F-Cap Screw

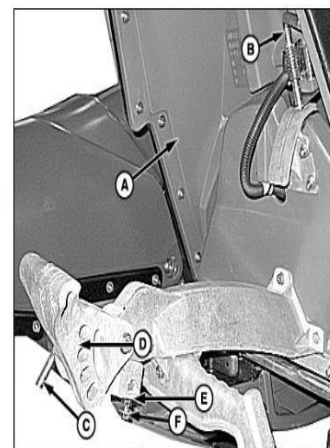

ADJUST SNOOT AS NEEDED WHEN SETTING THE CORRECT HEAD ANGLE

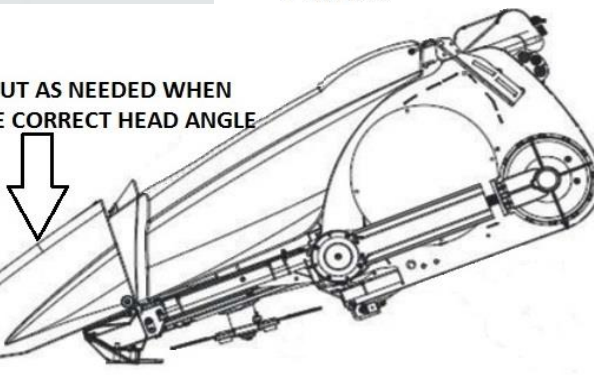

STORAGE/TRANSPORT

- Head cart may need adjusted to fit the head with devastator correctly. E.g. raising or fore/aft adjustment of saddles/top rail on the head cart.
- If head cart does not have these adjustments, adding a tube extension to top rail or adding extension to saddle/corn head may be required.
- Side to side tilt may need used to clear taller head cart tires or locking the devastator up.
- When disconnecting from the head, leaving pressure on the torsion pivot of the devastator will not damage the devastator.

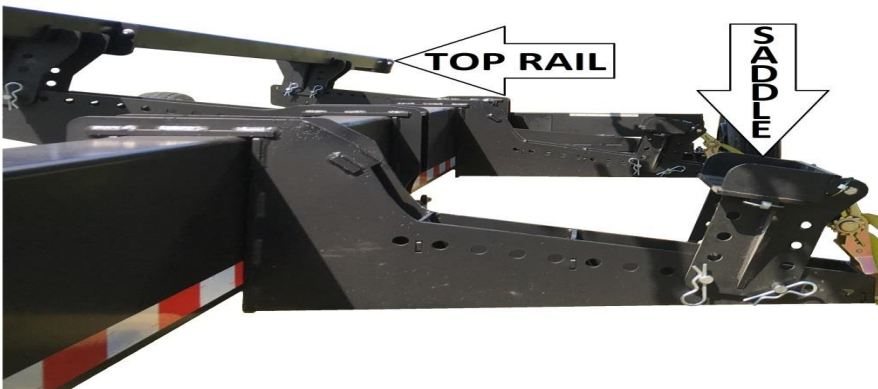

BEARING REPLACEMENT / MAINTENANCE



NOTE: WOBBLE BEARING HOUSING SHOULD BE LUBRICATED WITH POLYUREA GREASE BEFORE USE AND THEN EVERY 100 HOURS OF OPERATION

Put bearing housing in a vice, use a pry bar to turn bearing in the housing parallel with the slots, remove old bearing, (for older non-greaseable housing apply anti-seize lubricant to the interior of the bearing housing) , insert the new bearing in the slots, & use a pry bar to move back to position. Wobble bearing around to help work the lubricant into the outer race of the bearing.



5000-040C & 5000-040A-GER PART IDENTIFICATION

JD 606C/706C/C6R & GERINGHOFF 6R30 MODELS

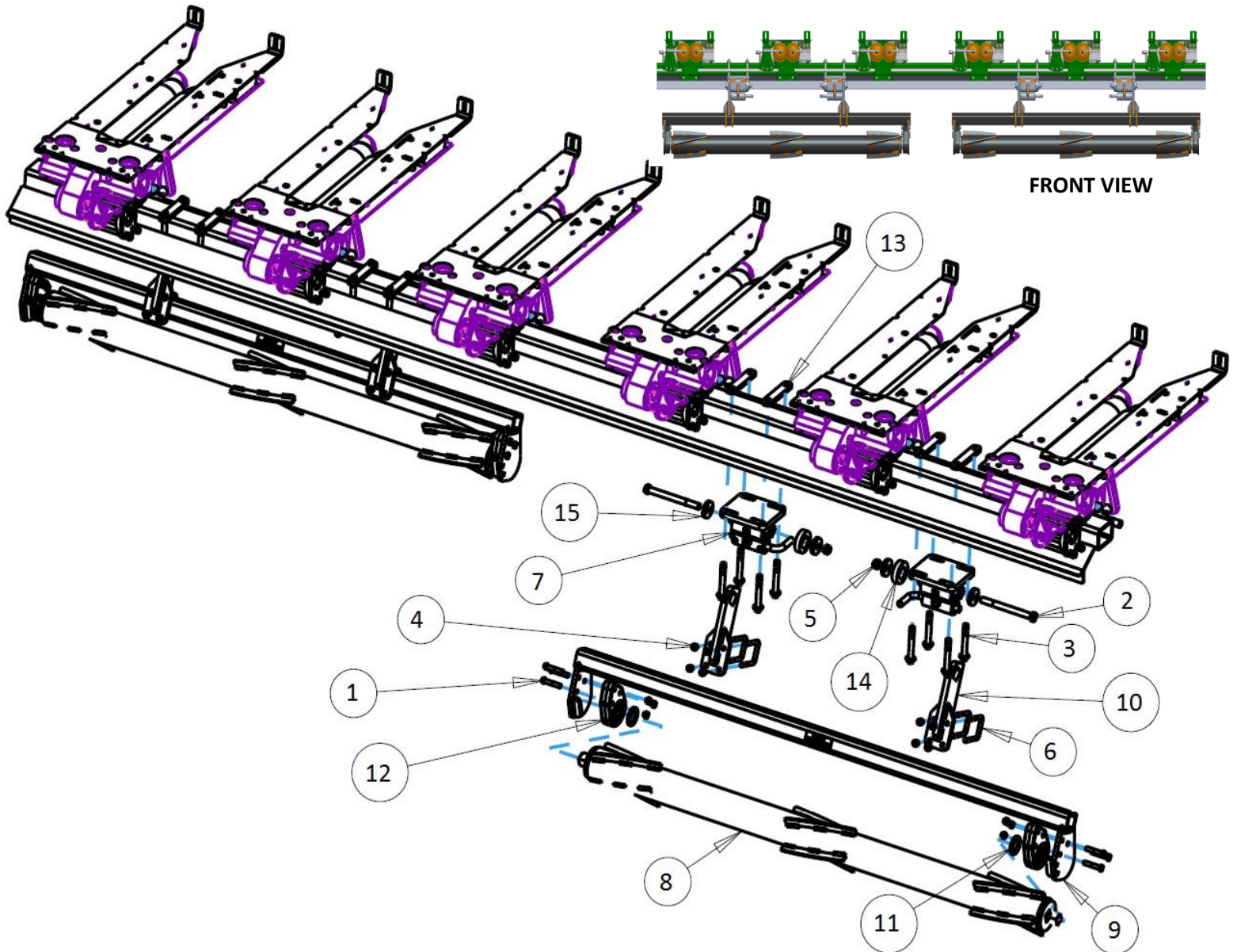

ITEM	PART #	DESCRIPTION	QUANTITY
1	2502-353	1/2 - 13 X 2 1/2 HHCS GR 8 ZP	12
2	2502-430	3/4 - 10 X 8 HHCS GR 8 ZP	4
3	2502-805	M16 X 2 X 120 HEX FLANGE BOLT, THREADLOCK, ZP (USED ONLY IN GEAR BOXES)	16
	2502-806	M16 X 2 X 110 HEX FLANGE BOLT, THREADLOCK, ZP (USED ONLY IN 4" CLAMP STRAPS)	16
4	2520-357	1/2-13 LOCK HEX NUT, GR A, ZP	28
5	2520-604	3/4 - 10 HEX TOP LOCK NUT	4
6	2570-568	1/2 X 2 1/2 X 3 1/2 U-BOLT	8
7	5000-187	LOCKING TORSION ASSEMBLY (USED ONLY IN 5000-040C)	4
	5000-184	LOCKING TORSION ASSEMBLY (USED ONLY IN 5000-040A-GER)	4
8	5000-272	3R30 ROLLER W.A.	2
9	5000-275A	4R20/3R30 ROLLER MOUNT W.A.	2
10	5000-292	TORSION ARM W.A.	4
11	5000-322	SHIM WASHER W.A.	4
12	5000-355	BEARING ASSEMBLY	4
	2550-059	DEVASTATOR BEARING (NO CAST HOUSING)	4
13	5000-420	4" CLAMP STRAP, TAPPED	8
14	5000-468	SPACER	4
15	5000-469	SECURITY CAP	8
	5000-072	GERINGHOFF ADAPTOR KIT (NOT SHOWN, USED ONLY IN 5000-040A-GER)	4

5000-041C & 5000-041A-GER PART IDENTIFICATION

JD 608C/708C/C8R & GERINGHOFF 8R30 MODELS

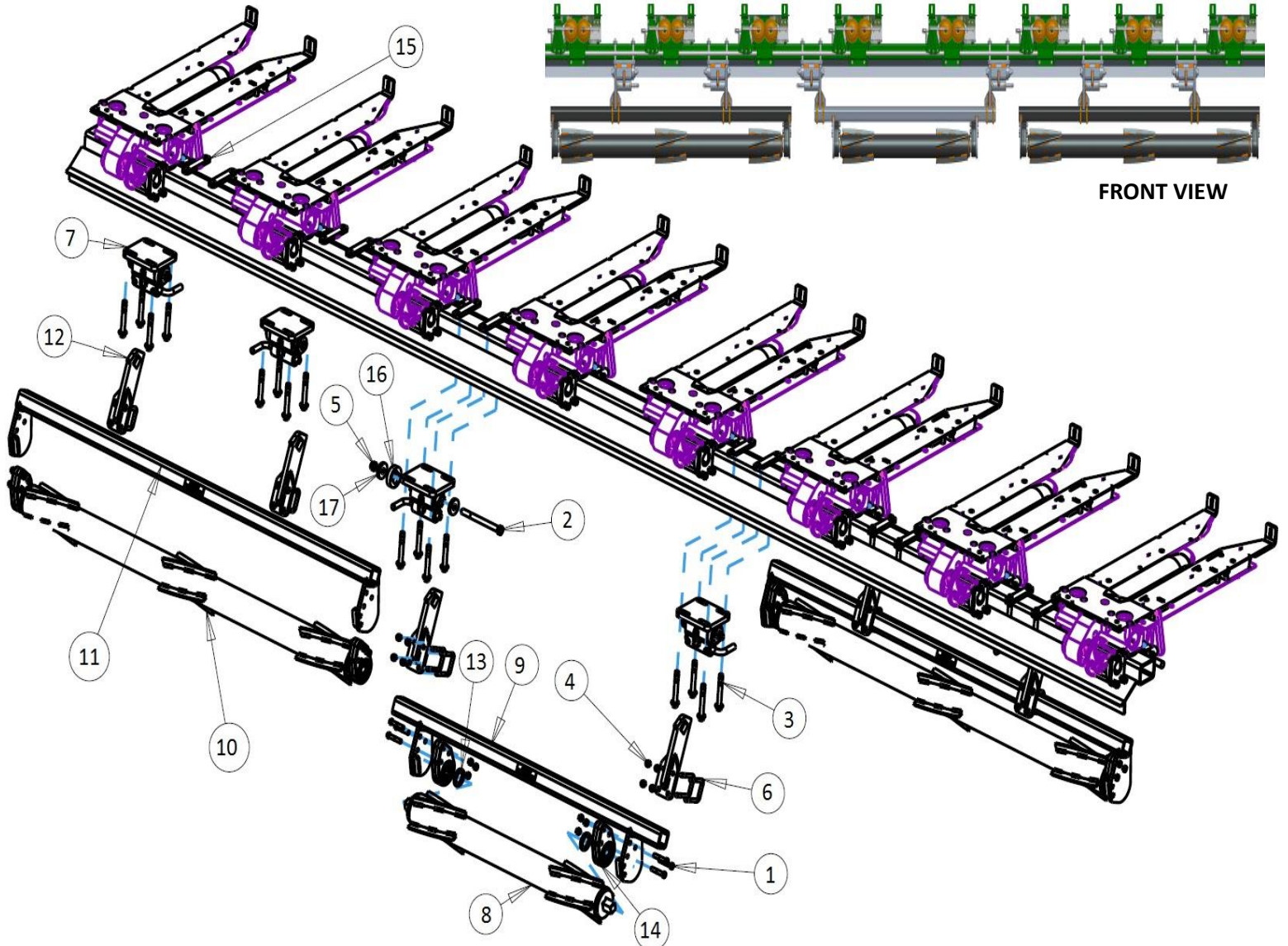

FRONT VIEW

ITEM	PART #	DESCRIPTION	QUANTITY
1	2502-353	½ - 13 X 2 ½ HHCS GR 8 ZP	18
2	2502-430	¾ - 10 X 8 HHCS GR 8 ZP	6
3	2502-805	M16 X 2 X 120 HEX FLANGE BOLT, THREADLOCK, ZP (USED ONLY IN GEAR BOXES)	24
	2502-806	M16 X 2 X 110 HEX FLANGE BOLT, THREADLOCK, ZP (USED ONLY IN 4" CLAMP STRAPS)	24
4	2520-357	1/2-13 LOCK HEX NUT, GR A, ZP	42
5	2520-604	¾ - 10 HEX TOP LOCK NUT	6
6	2570-568	½ X 2 ½ X 3 ½ U-BOLT	12
7	5000-187	LOCKING TORSION ASSEMBLY (USED ONLY IN 5000-041C)	6
	5000-184	LOCKING TORSION ASSEMBLY (USED ONLY IN 5000-041A-GER)	6
8	5000-268	2R30 ROLLER W.A.	1
9	5000-269A	2R30 ROLLER MOUNT W.A.	1
10	5000-272	3R30 ROLLER W.A.	2
11	5000-275A	4R20/3R30 ROLLER MOUNT W.A.	2
12	5000-292	TORSION ARM W.A.	6
13	5000-322	SHIM WASHER ZP	6
14	5000-355	BEARING ASSEMBLY	6
	2550-059	DEVASTATOR BEARING (NO CAST HOUSING)	6
15	5000-420	4" CLAMP STRAP, TAPPED	12
16	5000-468	SPACER	6
17	5000-469	SECURITY CAP	12
N/A	5000-072	GERINGHOFF ADAPTOR KIT (NOT SHOWN, USED ONLY IN 5000-041A-GER)	6

5000-042C & 5000-042A-GER PART IDENTIFICATION

JD 1290/612C/712C/C12R & GERINGHOFF 12R20 MODELS

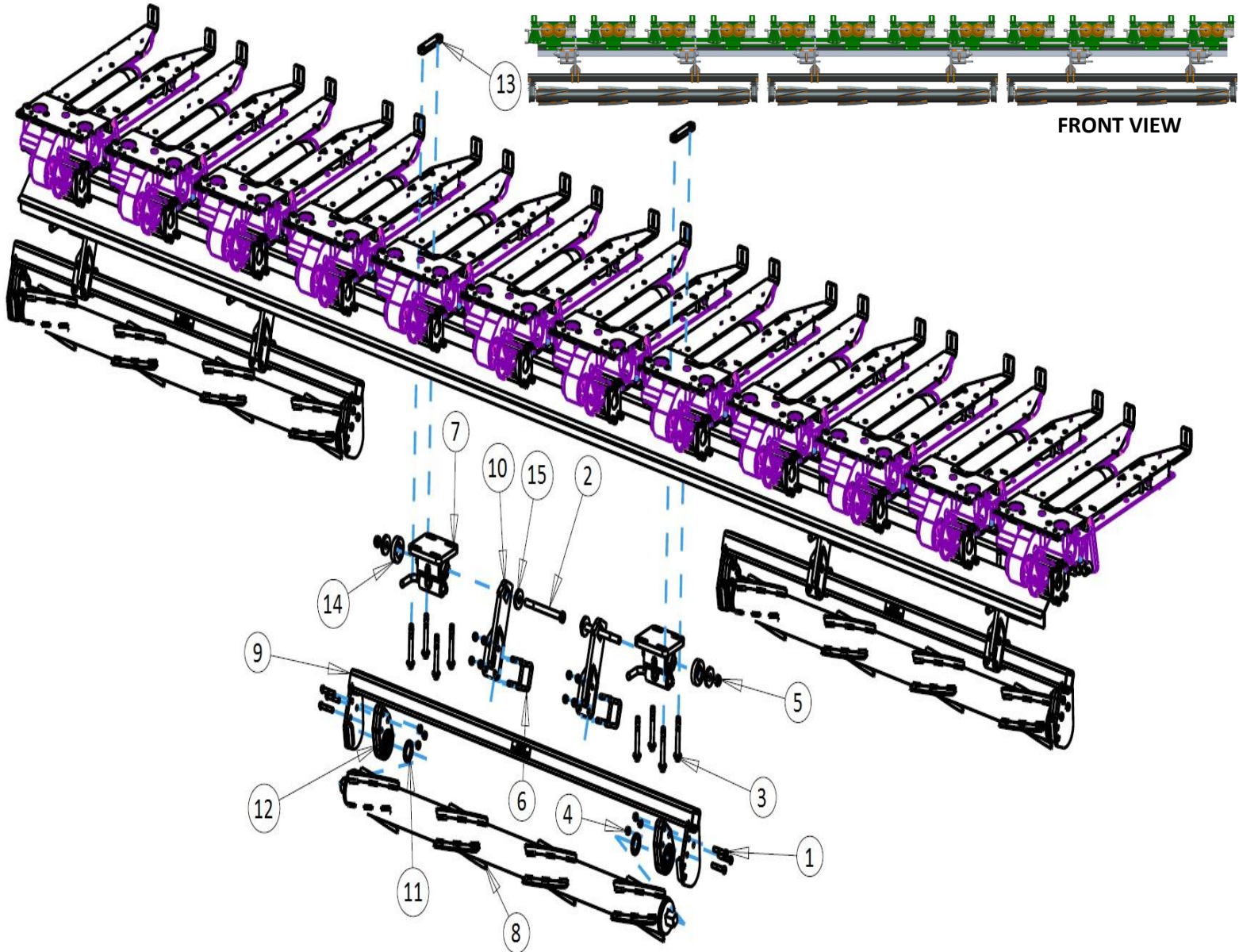

ITEM	PART #	DESCRIPTION	QUANTITY
1	2502-353	½ - 13 X 2 ½ HHCS GR 8 ZP	18
2	2502-430	¾ - 10 X 8 HHCS GR 8 ZP	6
3	2502-805	M16 X 2 X 120 HEX FLANGE BOLT, THREADLOCK, ZP (USED ONLY IN GEAR BOXES)	24
	2502-806	M16 X 2 X 110 HEX FLANGE BOLT, THREADLOCK, ZP (USED ONLY IN 4" CLAMP STRAPS)	24
4	2520-357	1/2-13 LOCK HEX NUT, GR A, ZP	42
5	2520-604	¾ - 10 HEX TOP LOCK NUT	6
6	2570-568	½ X 2 ½ X 3 ½ U-BOLT	12
7	5000-187	LOCKING TORSION ASSEMBLY (USED ONLY IN 5000-042C)	6
	5000-184	LOCKING TORSION ASSEMBLY (USED ONLY IN 5000-042A-GER)	6
8	5000-267	4R20 ROLLER W.A.	3
9	5000-275A	4R20/3R30 ROLLER MOUNT W.A.	3
10	5000-292	TORSION ARM W.A.	6
11	5000-322	SHIM WASHER ZP	6
12	5000-355	BEARING ASSEMBLY	6
	2550-059	DEVASTATOR BEARING (NO CAST HOUSING)	6
13	5000-420	4" CLAMP STRAP, TAPPED	6
14	5000-468	SPACER	6
15	5000-469	SECURITY CAP	12
	5000-072	GERINGHOFF ADAPTOR KIT (NOT SHOWN, USED ONLY IN 5000-042A-GER)	6

5000-042B-CNH PART IDENTIFICATION

CNH 2212, 2412, 3412 & NH 96C, 996, & NH98D 12R20 MODELS

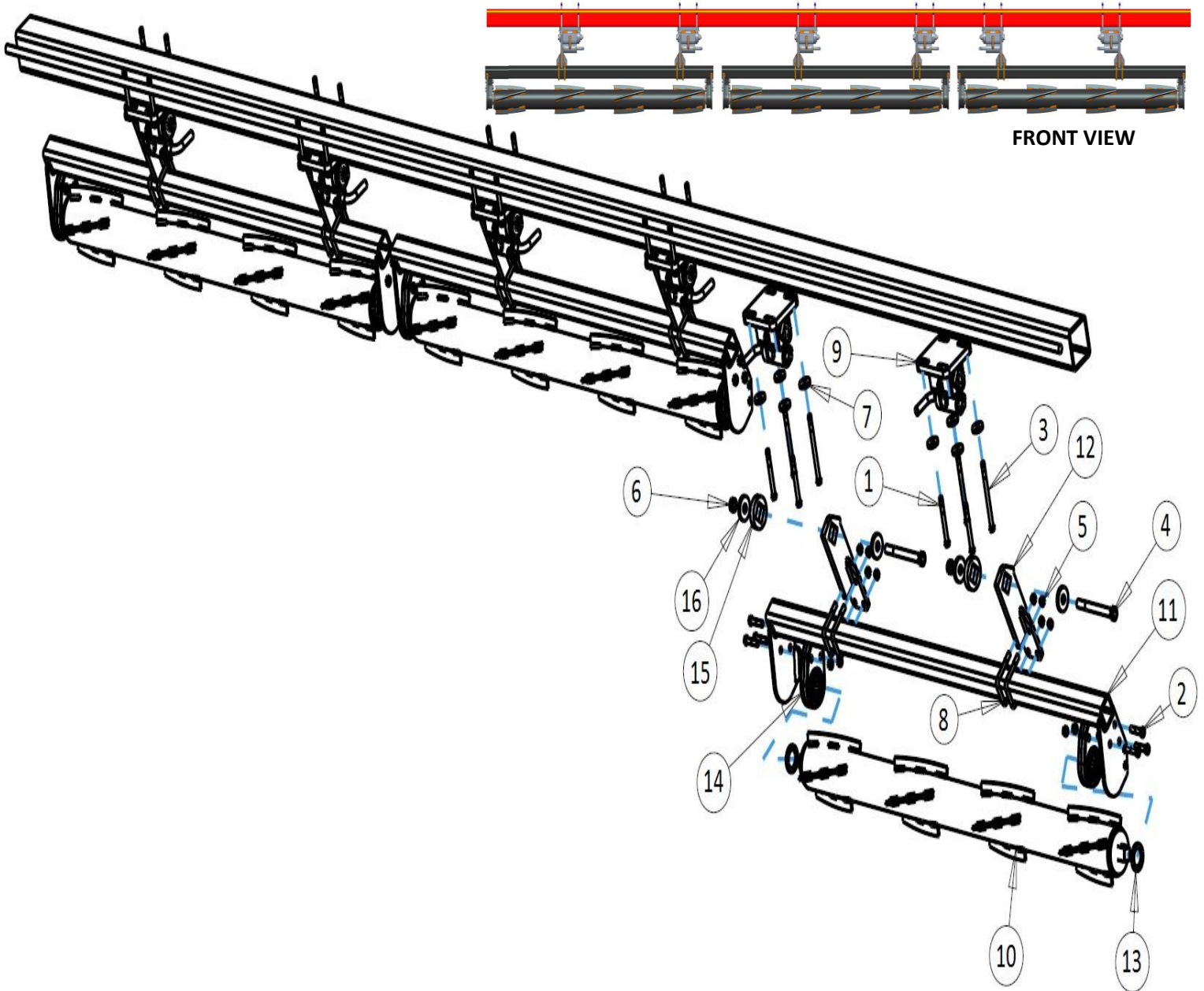

ITEM	PART #	DESCRIPTION	QUANTITY
1	2502-279	1/2 - 13 X 4 1/2 GR 5 ZN, TORQ-PATCH	12
2	2502-353	1/2 - 13 X 2 1/2 HHCS GR 8 ZP	18
3	2502-359	1/2 - 13 X 6 1/2 HHCS GR 5 ZN, TORQ-PART	12
4	2502-430	3/4 - 10 X 8 HHCS GR 8 ZP	6
5	2520-357	1/2-13 LOCK HEX NUT, GR A, ZP	42
6	2520-604	3/4 - 10 HEX TOP LOCK NUT	6
7	2526-402	9/16ID X 1 3/4OD Z 1/4MB ZP	24
8	2570-568	1/2 X 2 1/2 X 3 1/2 U-BOLT	12
9	5000-187	LOCKING TORSION ASSEMBLY	6
10	5000-267	4R20 ROLLER W.A.	3
11	5000-275A	4R20/3R30 ROLLER MOUNT W.A.	3
12	5000-292	TORSION ARM W.A.	6
13	5000-322	SHIM WASHER ZP	6
14	5000-355	BEARING ASSEMBLY	6
	2550-059	DEVASTATOR BEARING (NO CAST HOUSING)	6
15	5000-468	SPACER	6
16	5000-469	SECURITY CAP	12

5000-044C & 5000-044A-GER PART IDENTIFICATION

JD 1293/612C/712C/C12F/C12R & GERINGHOFF 12R30 MODELS

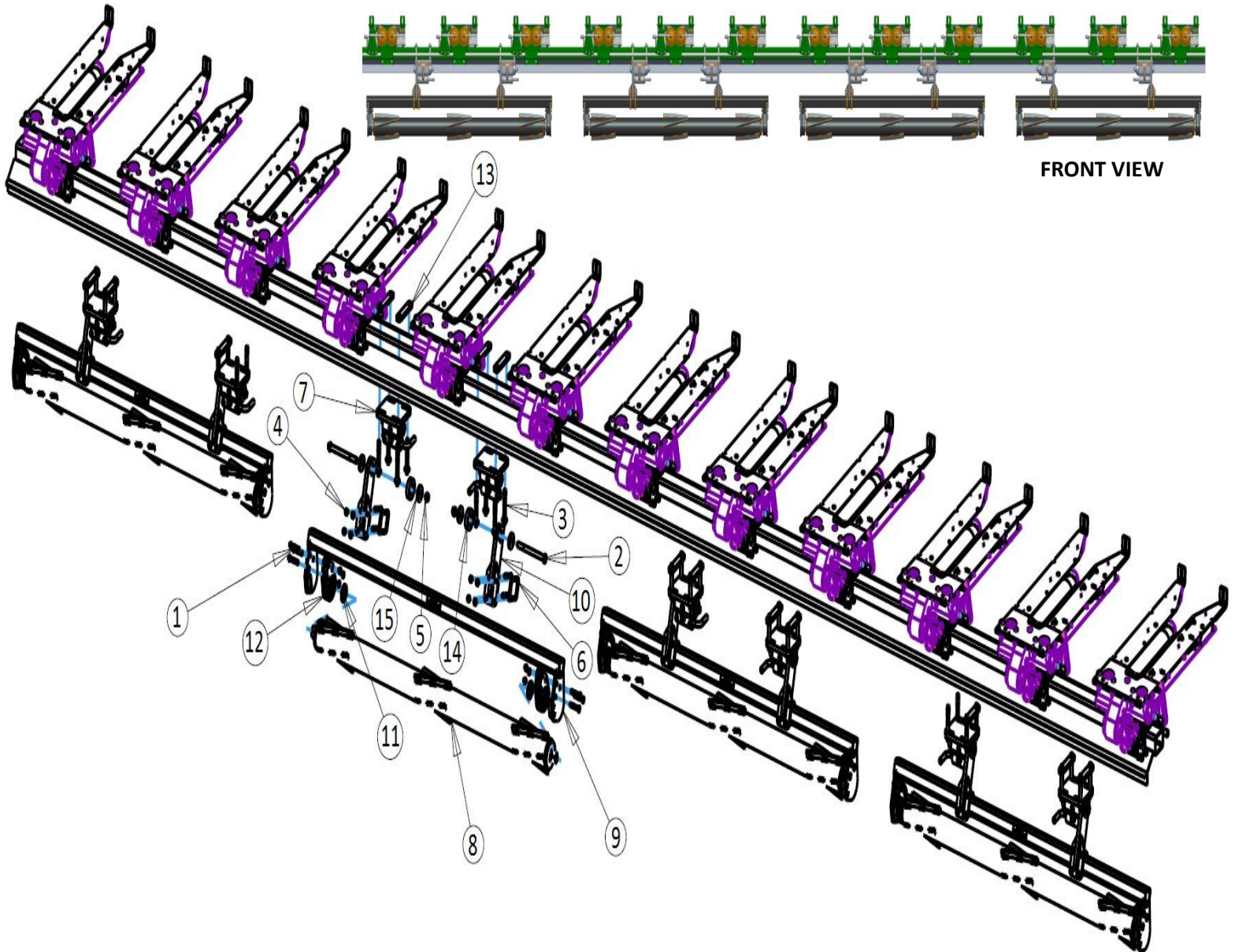

FRONT VIEW

ITEM	PART #	DESCRIPTION	QUANTITY
1	2502-353	1/2 - 13 X 2 1/2 HHCS GR 8 ZP	24
2	2502-430	3/4 - 10 X 8 HHCS GR 8 ZP	8
3	2502-805	M16 X 2 X 120 HEX FLANGE BOLT, THREADLOCK, ZP (USED ONLY IN GEAR BOXES)	32
	2502-806	M16 X 2 X 110 HEX FLANGE BOLT, THREADLOCK, ZP (USED ONLY IN 4" CLAMP STRAPS)	32
4	2520-357	1/2-13 LOCK HEX NUT, GR A, ZP	56
5	2520-604	3/4 - 10 HEX TOP LOCK NUT	8
6	2570-568	1/2 X 2 1/2 X 3 1/2 U-BOLT	16
7	5000-187	LOCKING TORSION ASSEMBLY (USED ONLY IN 5000-044C)	8
	5000-184	LOCKING TORSION ASSEMBLY (USED ONLY IN 5000-044A-GER)	8
8	5000-272	3R30 ROLLER W.A.	4
9	5000-275A	4R20/3R30 ROLLER MOUNT W.A.	4
10	5000-292	TORSION ARM W.A.	8
11	5000-322	SHIM WASHER ZP	8
12	5000-355	BEARING ASSEMBLY	8
	2550-059	DEVASTATOR BEARING (NO CAST HOUSING)	8
13	5000-420	4" CLAMP STRAP, TAPPED	14
14	5000-468	SPACER	8
15	5000-469	SECURITY CAP	16
	5000-072	GERINGHOFF ADAPTOR KIT (NOT SHOWN, USED ONLY IN 5000-044A-GER)	8

5000-045C & 5000-045A-GER PART IDENTIFICATION

JD 618C/718C/C18F/C18R & GERINGHOFF 18R20 MODELS

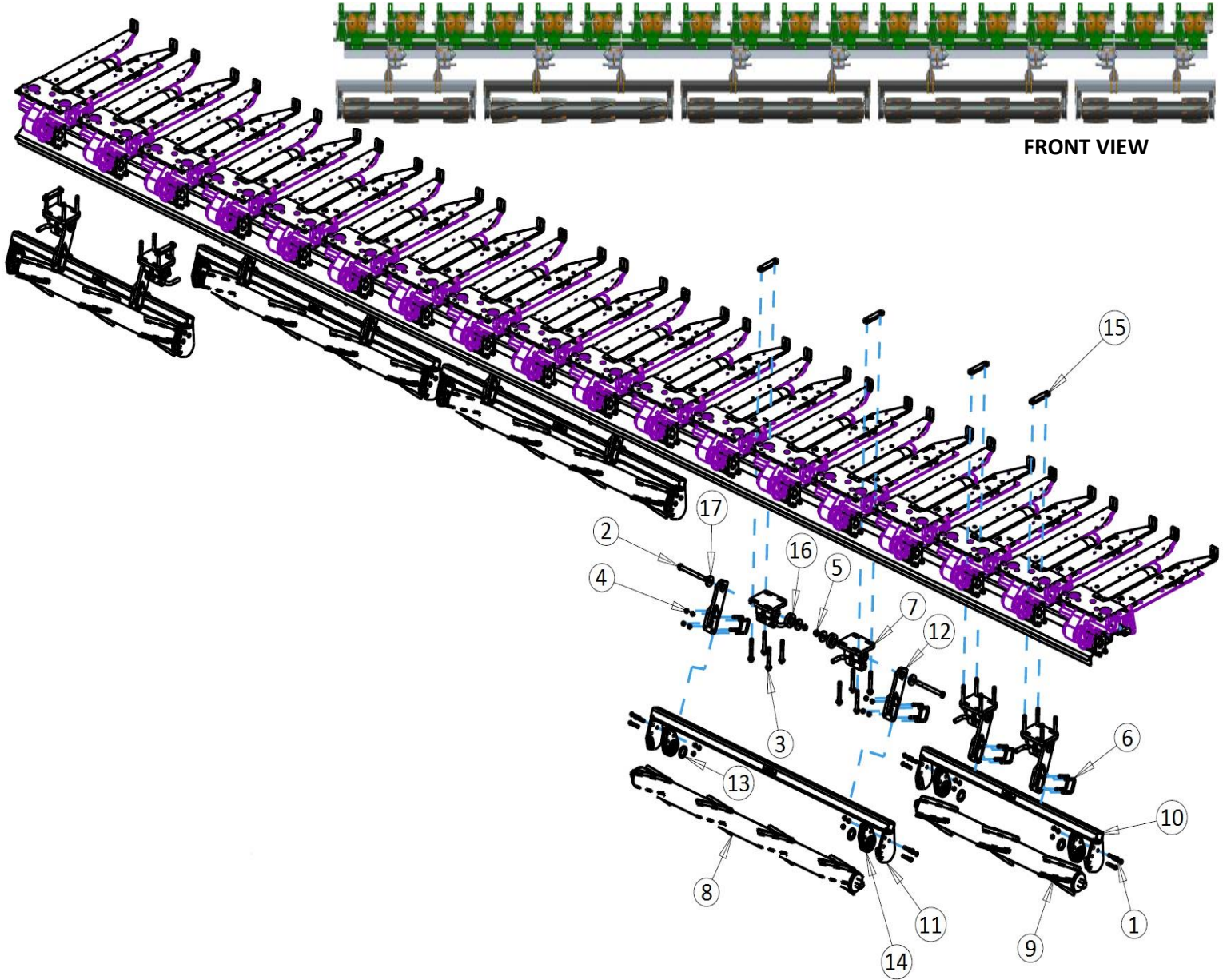

ITEM	PART #	DESCRIPTION	QUANTITY
1	2502-353	½ - 13 X 2 ½ HHCS GR 8 ZP	30
2	2502-430	¾ - 10 X 8 HHCS GR 8, ZP	10
3	2502-805	M16 X 2 X 120 HEX FLANGE BOLT, THREADLOCK, ZP (USED ONLY IN GEAR BOXES)	40
	2520-806	M16 X 2 X 110 HEX FLANGE BOLT, THREADLOCK, ZP (USED ONLY IN 4" CLAMP STRAPS)	40
4	2520-357	1/2-13 LOCK HEX NUT, GR A, ZP	70
5	2520-604	¾ - 12 HEX TOP LOCK	10
6	2570-568	½ X 2 ½ X 3 ½ U-BOLT	20
7	5000-187	LOCKING TORSION ASSEMBLY (USED ONLY IN 5000-045C)	10
	5000-184	LOCKING TORSION ASSEMBLY (USED ONLY IN 5000-045A-GER)	10
8	5000-267	4R20 ROLLER W.A.	3
9	5000-273	3R20 ROLLER W.A.	2
10	5000-274A	3R20 ROLLER MOUNT W.A.	2
11	5000-275A	4R20/3R30 ROLLER MOUNT W.A.	3
12	5000-292	TORSION ARM W.A.	10
13	5000-322	SHIM WASHER ZP	10
14	5000-355	BEARING ASSEMBLY	10
	2550-059	DEVASTATOR BEARING (NO CAST HOUSING)	10
15	5000-420	4" CLAMP STRAP, TAPPED	10
16	5000-468	SPACER	10
17	5000-469	SECURITY CAP	20
	5000-072	GERINGHOFF ADAPTOR KIT (NOT SHOWN, USED ONLY IN 5000-045A-GER)	10

5000-046C & 5000-046A-GER PART IDENTIFICATION

JD 612C/712C/C12R & GERINGHOFF 12R22 MODELS

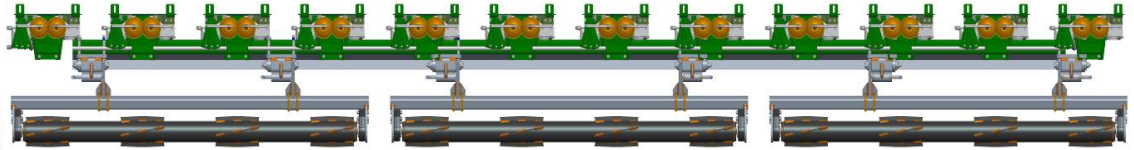

FRONT VIEW

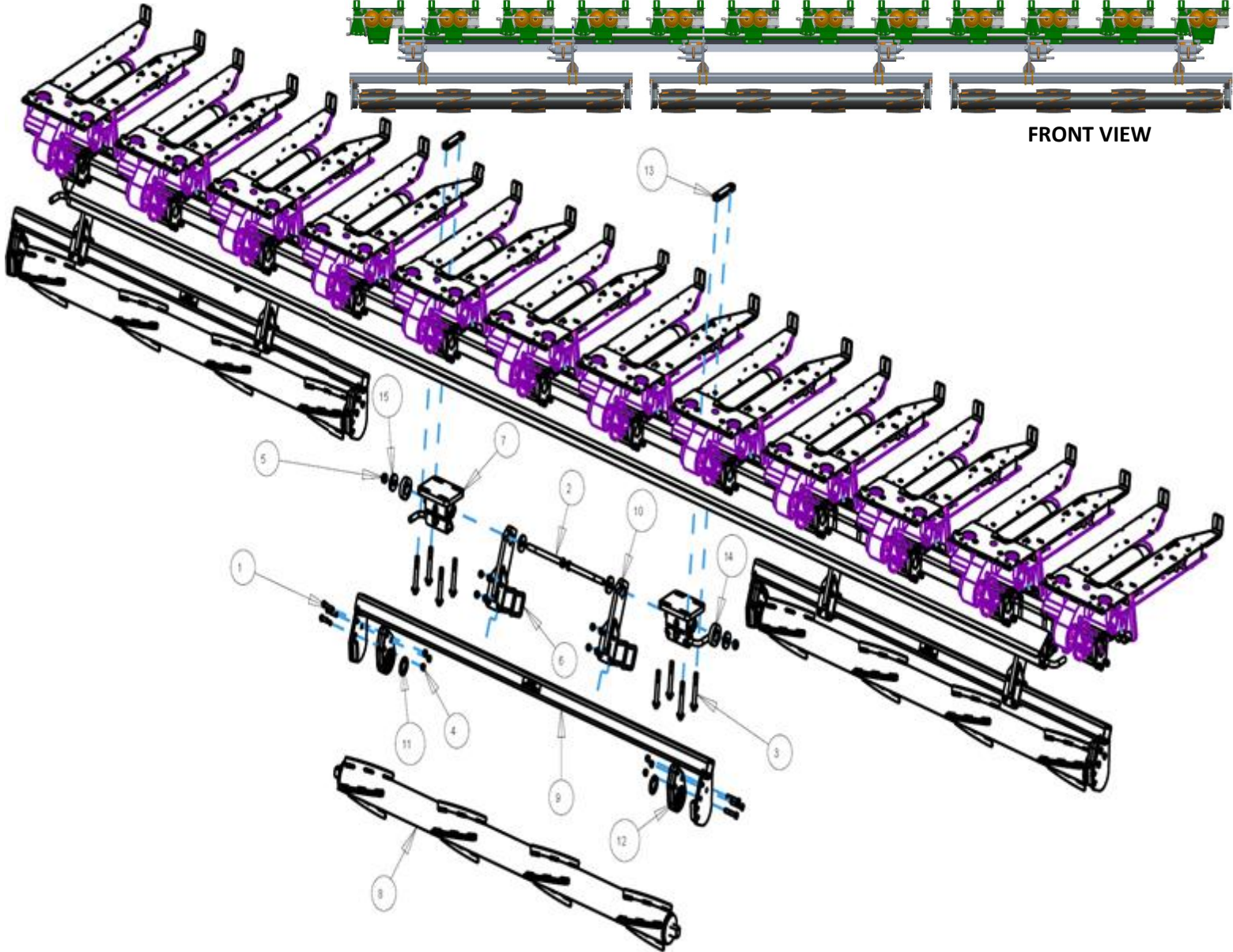

ITEM	PART #	DESCRIPTION	QUANTITY
1	2502-353	1/2 - 20 X 2 1/2"	18
2	2502-430	3/4 - 10 X 8 HHCS GR 8 ZP	6
3	2502-805	M16 X 2 X 120 HEX FLANGE BOLT, THREADLOCK, ZP (USED ONLY IN GEAR BOXES)	24
	2502-806	M16 X 2 X 110 HEX FLANGE BOLT, THREADLOCK, ZP (USED ONLY IN 4" CLAMP STRAPS)	24
4	2520-357	1/2-13 LOCK HEX NUT, GR A, ZP	42
5	2520-604	3/4 - 10 HEX TOP LOCK NUT	6
6	2570-568	1/2 X 2 1/2 X 3 1/2 U-BOLT	12
7	5000-187	LOCKING TORSION ASSEMBLY (USED ONLY IN 5000-046C)	6
	5000-184	LOCKING TORSION ASSEMBLY (USED ONLY IN 5000-046A-GER)	6
8	5000-282	4R22 ROLLER W.A.	3
9	5000-283A	4R22 ROLLER MOUNT W.A.	3
10	5000-292	TORSION ARM W.A.	6
11	5000-322	SHIM WASHER ZP	6
12	5000-355	BEARING ASSEMBLY	6
	2550-059	DEVASTATOR BEARING (NO CAST HOUSING)	6
13	5000-420	4" CLAMP STRAP, TAPPED	6
14	5000-468	SPACER	6
15	5000-469	SECURITY CAP	12
	5000-072	GERINGHOFF ADAPTOR KIT (NOT SHOWN, USED ONLY IN 5000-046A-GER)	6

5000-046B-CNH PART IDENTIFICATION

CNH 2212, 2412, 3412 & NH 96C, 996, & NH98D 12R22 MODELS

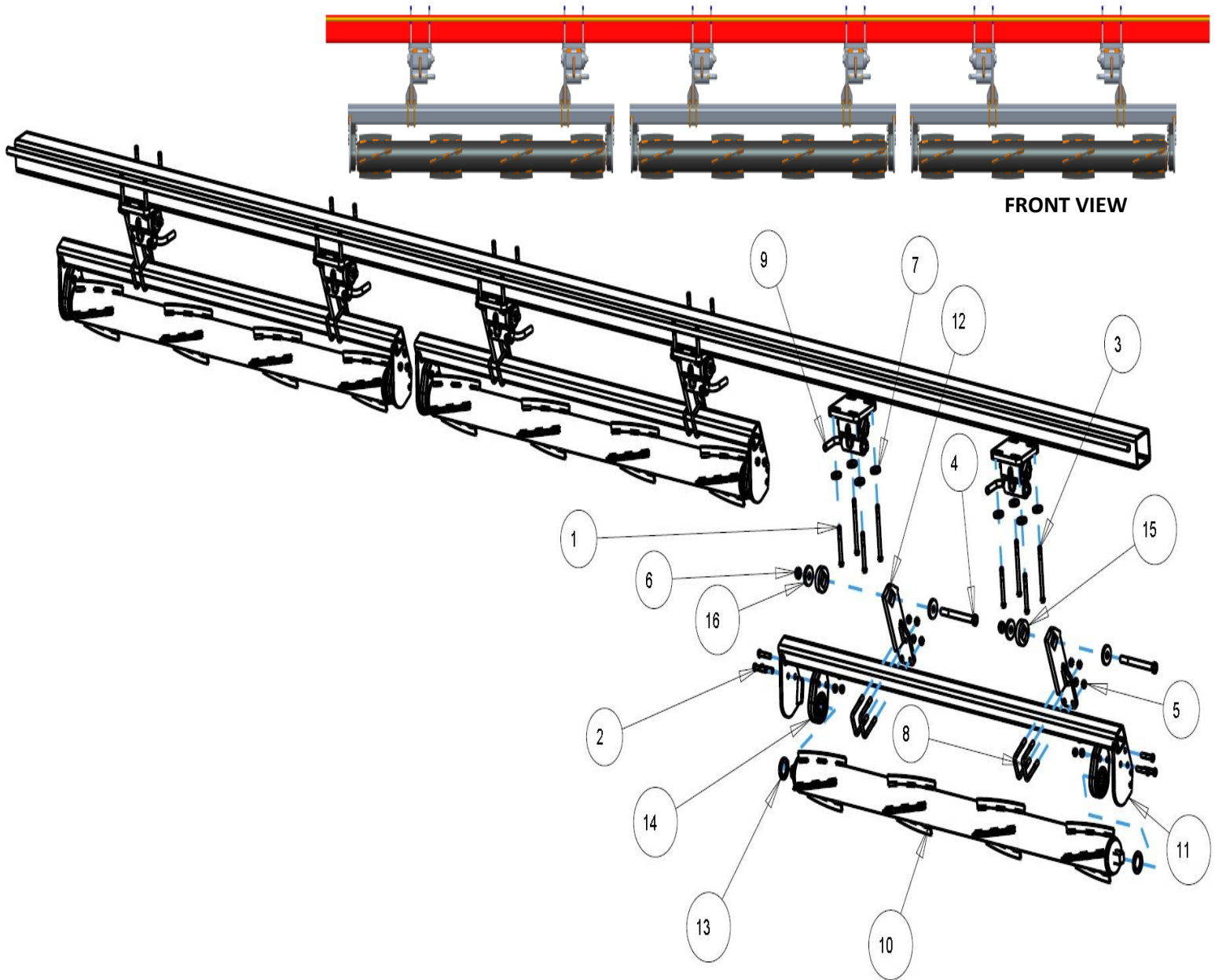

ITEM	PART #	DESCRIPTION	QUANTITY
1	2502-279	½ - 13 X 4 ½ GR 5 ZN, TORQ-PATCH	12
2	2502-353	½ - 13 X 2 ½ HHCS GR 8 ZP	18
3	2502-359	½ - 13 X 6 ½ HHCS GR 5 ZN, TORQ-PART	12
4	2502-430	¾ - 10 X 8 HHCS GR 8 ZP	6
5	2520-357	1/2-13 LOCK HEX NUT, GR A, ZP	42
6	2520-604	¾ - 10 HEX TOP LOCK NUT	6
7	2526-402	9/16ID X 1 3/4OD Z 1/4MB ZP	24
8	2570-568	½ X 2 ½ X 3 ½ U-BOLT	12
9	5000-187	LOCKING TORSION ASSEMBLY	6
10	5000-282	4R22 ROLLER W.A.	3
11	5000-283A	4R22ROLLER MOUNT W.A.	3
12	5000-292	TORSION ARM W.A.	6
13	5000-322	SHIM WASHER ZP	6
14	5000-355	BEARING ASSEMBLY	6
	2550-059	DEVASTATOR BEARING (NO CAST HOUSING)	6
15	5000-468	SPACER	6
16	5000-469	SECURITY CAP	12

5000-047C & 5000-047A-GER PART IDENTIFICATION

JD 618C/718C/C18F/C18R & GERINGHOFF 18R22 MODELS

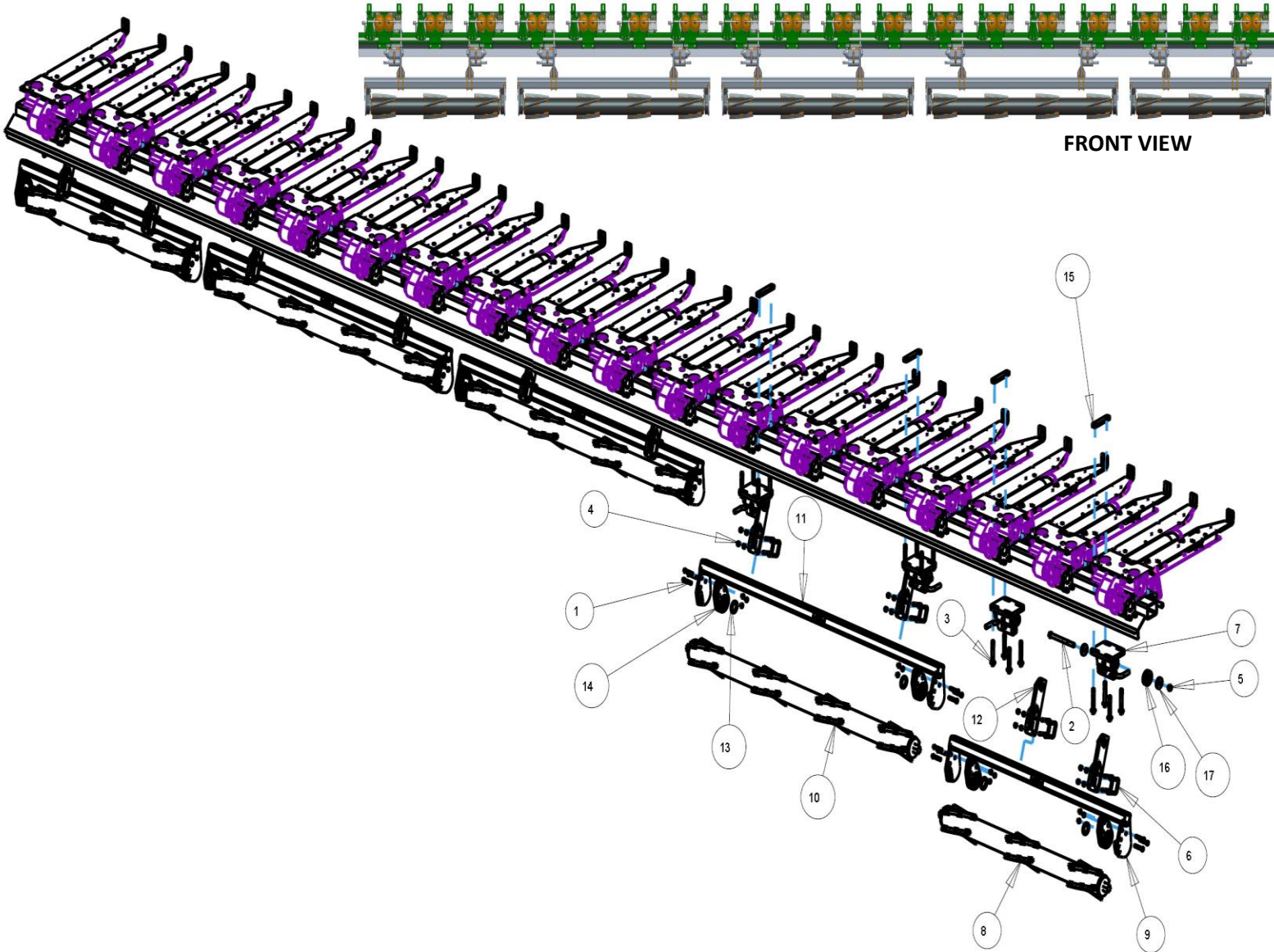

ITEM	PART #	DESCRIPTION	QUANTITY
1	2502-353	1/2" - 13 x 2 1/2 HHCS GR 8 ZP	30
2	2502-430	3/4 - 10 X 8 HHCS GR 8 ZP	10
3	2502-805	M16 X 2 X 120 HEX FLANGE BOLT, THREADLOCK, ZP (USED ONLY IN GEAR BOXES)	40
	2502-806	M16 X 2 X 110 HEX FLANGE BOLT, THREADLOCK, ZP (USED ONLY IN 4" CLAMP STRAPS)	40
4	2520-357	1/2-13 LOCK HEX NUT, GR A, ZP	70
5	2520-604	3/4 - 10 HEX TOP LOCK NUT	10
6	2570-568	1/2 X 2 1/2 X 3 1/2 U-BOLT	20
7	5000-187	LOCKING TORSION ASSEMBLY (USED ONLY IN 5000-047C)	10
	5000-184	LOCKING TORSION ASSEMBLY, GERINGHOFF (USED ONLY IN 5000-047A-GER)	10
8	5000-280	3R22 ROLLER W.A.	2
9	5000-281A	3R22 ROLLER MOUNT W.A.	2
10	5000-282	4R22 ROLLER W.A.	3
11	5000-283A	4R22 ROLLER MOUNT W.A.	3
12	5000-292	TORSION ARM W.A.	10
13	5000-322	SHIM WASHER ZP	10
14	5000-355	BEARING ASSEMBLY	10
	2550-059	DEVASTATOR BEARING (NO CAST HOUSING)	10
15	5000-420	4" CLAMP STRAP, TAPPED	10
16	5000-468	SPACER	10
17	5000-469	SECURITY CAP	20
	5000-072	GERINGHOFF ADAPTOR KIT (NOT SHOWN, USED ONLY IN 5000-047A-GER)	10

5000-048 PART IDENTIFICATION

JD 8R30 FOLDING – 708F/C8F

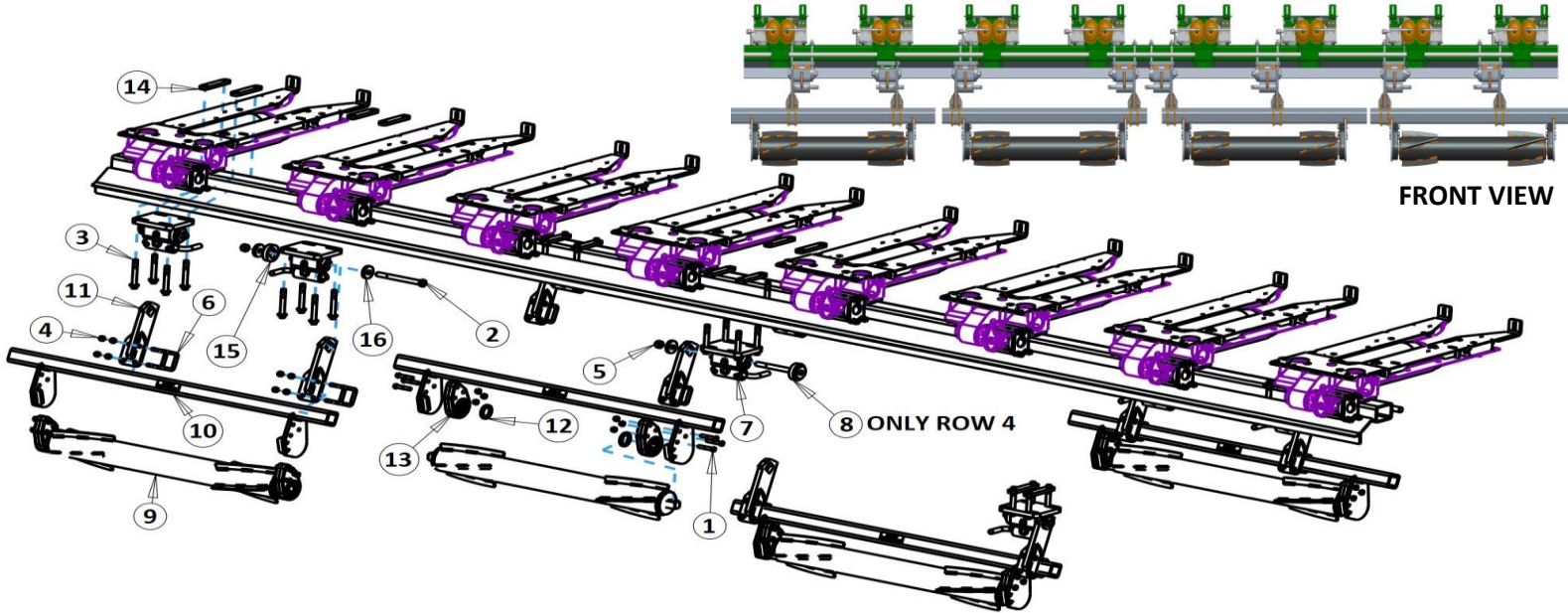

ITEM	PART #	DESCRIPTION	QTY
1	2502-353	½ - 13 X 2 ½ HHCS GR 8 ZP	24
2	2502-430	¾ - 10 X 8 HHCS GR 8 ZP	8
3	2502-805	M16 X 2 X 120 HEX FLANGE SCREW, THREAD LOCK, ZP	32
4	2520-357	½ - 13 LOCK HEX NUT GR A ZP	56
5	2520-604	¾ - 10 HEX TOP LOCK GR C ZP	8
6	2570-568	½ X 2 ½ X 3 ½ U BOLT	16
7	5000-187	LOCKING TORSION PIVOT ASSEMBLY	8
8	5000-2006	SPECIAL CAP BOLT W.A.	1

9	5000-268	2R30 ROLLER W.A.	
10	5000-269A	2R30 ROLLER MOUNT W.A.	4
11	5000-292	TORSION ARM W.A.	4
12	5000-322	SHIM WASHER ZP	8
13	5000-355	BEARING ASSEMBLY	8
	2550-059	BEARING ONLY (NO CAST HOUSING)	8
14	5000-420	4" CLAMP STRAP, TAPPED	16
15	5000-468	SPACER	8
16	5000-469	SECURITY CAP	16

5000-070 PART IDENTIFICATION

JD 90/40 SERIES / CALMER – ADAPTOR

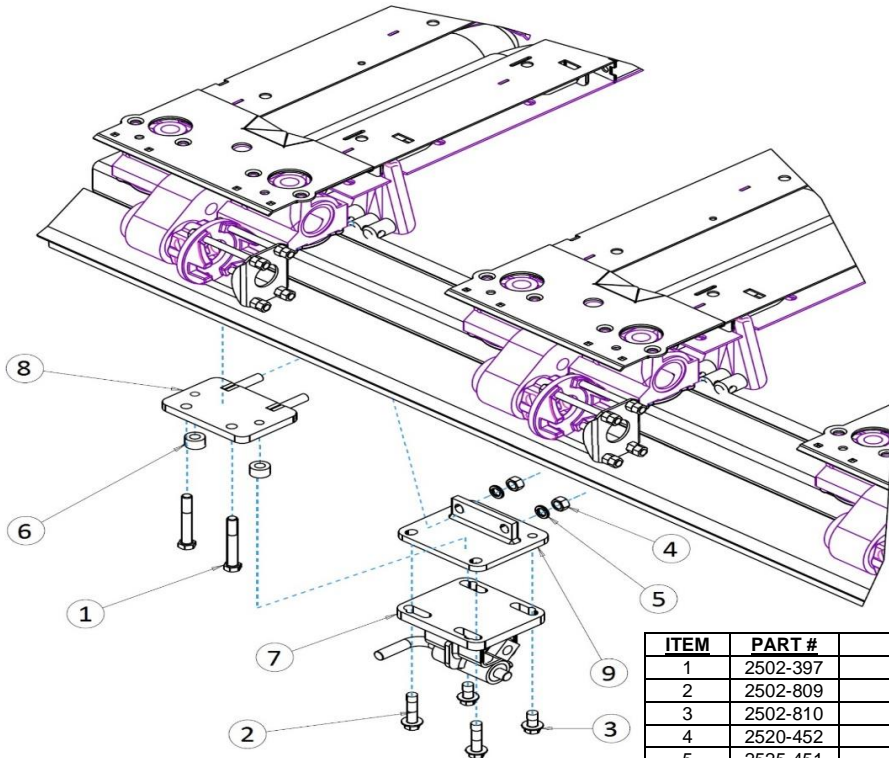

ITEM	PART #	DESCRIPTION	QTY
1	2502-397	5/8 - 11 X 5 ½ HHCS GR 5 ZP	2
2	2502-809	M16 X 2 X 65 HEX FLANGE SCREW, THREAD LOCK, ZP	2
3	2502-810	M16 X 2 X 30 HEX FLANGE SCREW, THREAD LOCK, ZP	2
4	2520-452	5/8 - 11 HEX NUT ZP, GR 8	2
5	2525-451	5/8 MEDIUM LOCK WASHER ZP	4
6	2967-302	¾" PLATE SPACER	2
7	5000-167	TORSION PIVOT ASSEMBLY (NOT INCLUDED IN THE 5000-070)	1
8	5000-284	CALMER ADAPTER BRACKET W.A.	1
9	5000-285	ADAPTER W.A.	1

5000-071 PART IDENTIFICATION

LEXION & CAPELLO – ADAPTOR

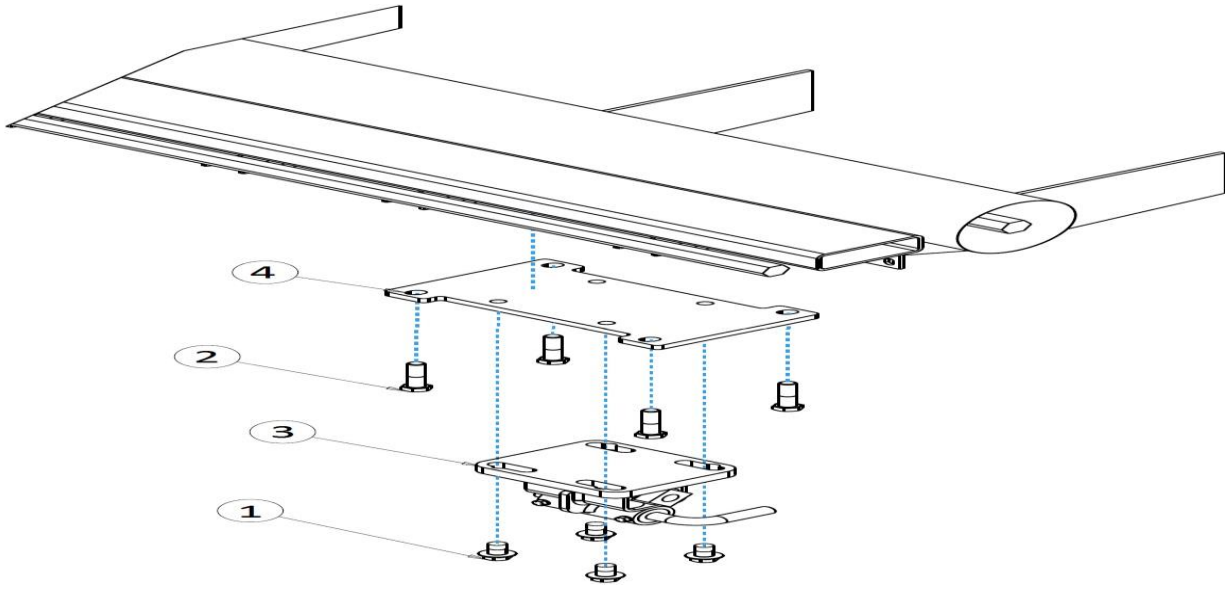

ITEM	PART #	DESCRIPTION	QUANTITY
1	2502-810	M16 X 2 X 30 HEX FLANGE SCREW, THREAD LOCK, ZP	4
2	2502-813	M16 X 2 X 70 8.8 HHCS ZP	4
3	5000-187	LOCKING TORSION ASSEMBLY (NOT INCLUDED IN 5000-071 KIT)	1
4	5000-452	CAPELLO/LEXION ADAPTER PLATE	1

5000-072 PART IDENTIFICATION

GERINGHOFF ADAPTOR

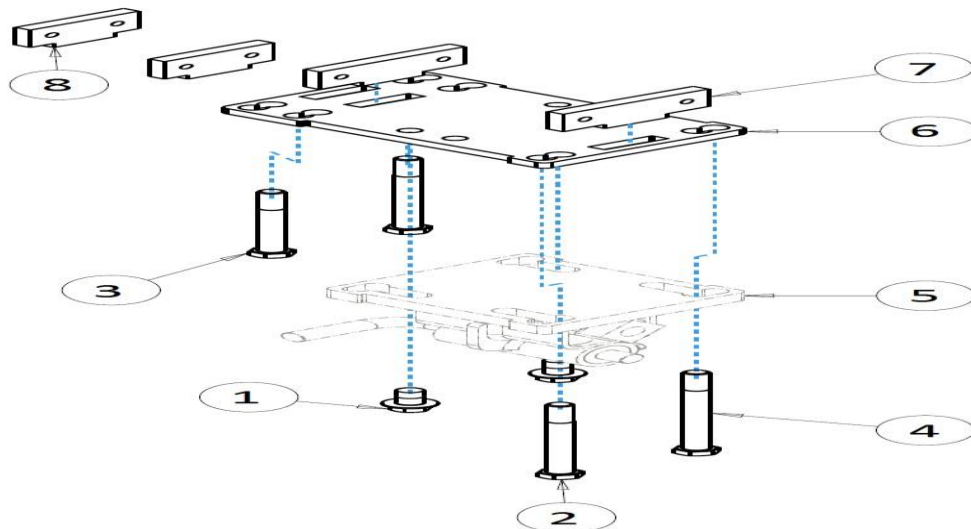

ITEM	PART #	DESCRIPTION	QUANTITY
1	2502-810	M16 X 2 X 30 HEX FLANGE SCREW, THREAD LOCK, ZP	2
2	2502-814	M16 X 2 X 160 8.8 HHCS ZP	2
3	2502-815	M16 X 2 X 140 8.8 HHCS ZP	1
4	2502-817	M16 X 2 X 180 8.8 HHCS ZP	1
5	5000-184	TORSION UNIT, GERINGHOFF (NOT INCLUDED IN THE 5000-072 KIT)	2
6	5000-453	GERINGHOFF ADAPTER PLATE	1
7	5000-454	SPACER (USED ON NON-HORIZON MODELS)	2
8	5000-472	SPACER (USED ONLY ON HORIZON MODELS)	2

PART IDENTIFICATION

5000-073

MAINERO ADAPTOR KIT

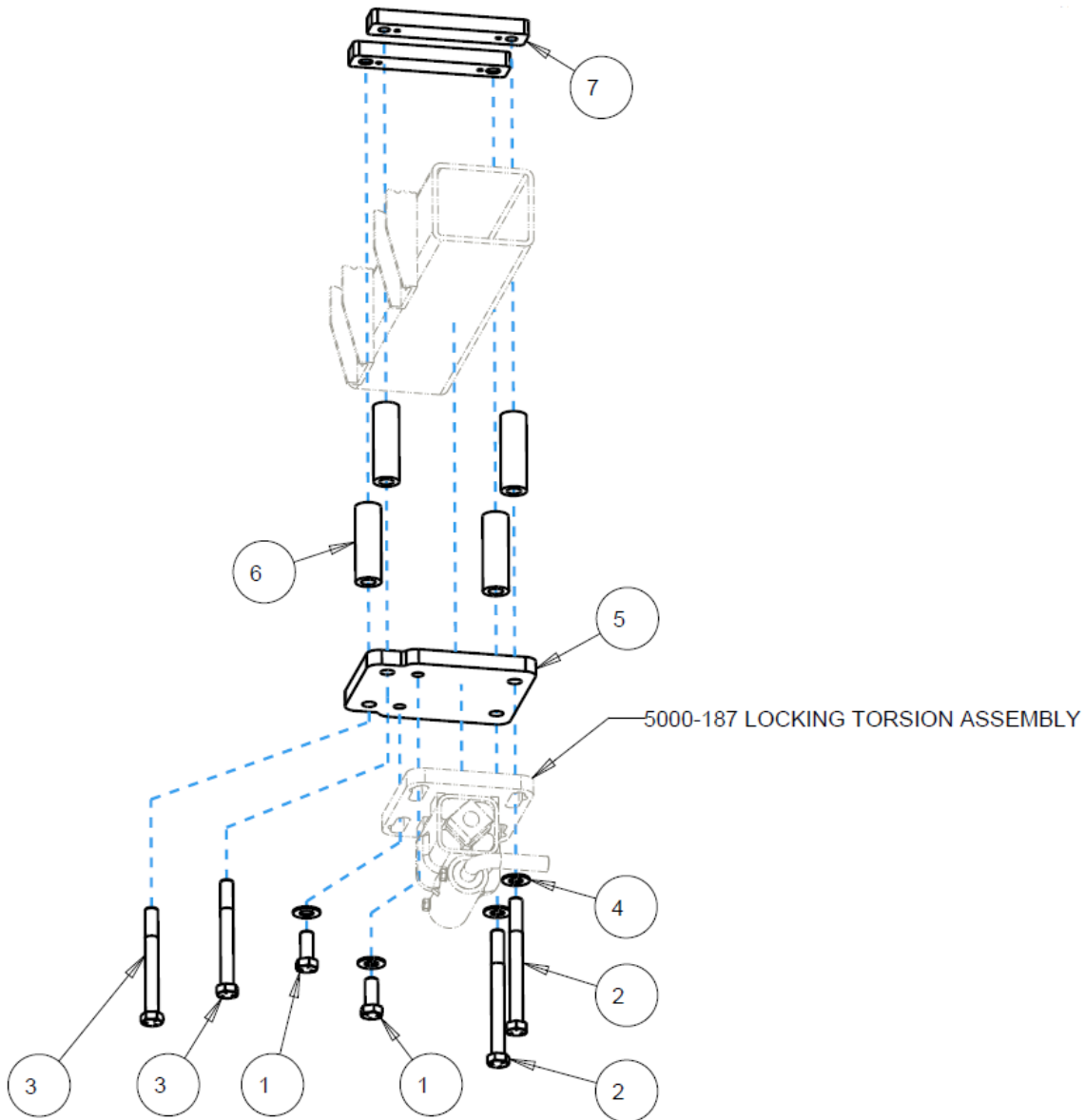

ITEM	PART #	DESCRIPTION	QUANTITY
1	2502-319	5/8-11 X 1-1/2 CAP SCREW GRADE 5	2
2	2502-395	5/8-11 X 6-1/2 CAP SCREW GRADE 5	2
3	2502-397	5/8-11 X 5-1/2 CAP SCREW GRADE 5	2
4	2526-453	5/8 SAE FLATWASHER	4
5	5000-509	MAINERO ADAPTER PLATE	1
6	5000-510	SLEEVE-MAINERO	4
7	5000-511	MOUNT STRAP-MAINERO	4

TROUBLESHOOTING

ISSUE	CAUSE	CORRECTIVE ACTION
Residue Plugging or wrapping	<ol style="list-style-type: none"> 1. Incorrect Head Angle 2. Roller Mount Tube incorrectly installed 3. Pivot arm orientation incorrect 4. Bearing installed incorrectly 5. Devastator bottomed out 	<ol style="list-style-type: none"> 1. Adjust head angle to 22 – 25 degrees (see page 15) 2. Make sure the Bearing Support Tab is on the backside of the Roller Arm Mount Tube 3. Reposition the pivot arm so that it offsets under the snout & not directly under the row 4. Make sure the side of the bearing that protrudes outside of the cast housing is facing away from the bearing plate. (each roller should spin freely by hand) 5. Raise head to allow travel, make sure angle is correct
Stalk aren't "devastated"	<ol style="list-style-type: none"> 1. Operating corn head too high 2. Traction Bar isn't over row 	<ol style="list-style-type: none"> 1. Lower head until the rollers engage, if roller is engaged, lowering head will apply more pressure to rollers 2. Add 5000-472 Traction Bar extensions Reposition Mount brackets/pivot arms to have more side to side adjustment
Corn Head won't fit on head cart	<ol style="list-style-type: none"> 1. Devastators bottom out 2. Roller won't clear cart tire 3. Storage stands don't rest in the saddles on the cart 	<ol style="list-style-type: none"> 1. Adjust top rail & saddles higher on cart 2. Use side tilt to clear tires (if using a dual rear axle cart) Pin Devastators Up 3. Order 5000-081 Head Extensions (JD 600 & 700 series only)
Bearing makes a clunking sound when barrel spins	<ol style="list-style-type: none"> 1. Slop in square shaft on the end of roller & the bearing allows the roller to drop 	<ol style="list-style-type: none"> 1. This is normal, no corrective action needed









A Tradition of Solutions since 1930

Yetter Farm Equipment Co

PO BOX 358 109 S. McDonough

Colchester, IL 62326-0358

Phone: 309-776-4111

Toll Free: 800-447-5777

Email: info@yetterco.com

For updated models and manuals visit the Yetter website:

www.yetterco.com

© Yetter Farm Equipment Co. All Rights Reserved

2565-965_REV_C – 06/2024