



**GENERATION III COULTER**  
**MODEL 2995**  
**SET-UP & PARTS MANUAL**

2565-490\_REV\_G • 08/2024

**YETTER MANUFACTURING CO.**  
*FOUNDED 1930*

Colchester, IL 62326-0358  
Toll free: 800/447-5777  
309/776-3222 (Fax)

Website: [www.yetterco.com](http://www.yetterco.com)  
E-mail: [info@yetterco.com](mailto:info@yetterco.com)

**YETTER**

# FOREWORD

You've just joined an exclusive but rapidly growing club.

For our part, we want to welcome you to the group and thank you for buying a Yetter product.

We hope your new Yetter products will help you achieve both goals-increase your productivity and increase your efficiency so that you may generate more profit.

This operator's manual has been designed into four major sections: Foreword, Safety Precautions, Installation Instructions and Parts Breakdown.

This **SAFETY ALERT SYMBOL** indicates important safety messages in the manual. When you see this symbol, be alert to the possibility of **PERSONAL INJURY** and carefully read the message that follows.

 **DANGER:** Indicates an imminently hazardous situation which, if not avoided "will" result in death or serious injury. This signal word is to be limited to the most extreme situations

 **WARNING:** Indicates a potentially hazardous situation which, if not avoided, "could" result in death or serious injury.

 **CAUTION:** Indicates a potentially hazardous situation, which if not avoided, "may" result in minor or moderate injury. It may also be used to alert against unsafe practices.

 **NOTICE:** Indicates information considered important, but not hazard related (e.g., messages relating to property damage).

It is the responsibility of the user to read the operator's manual and comply with the safe and correct operating procedure and to lubricate and maintain the product according to the maintenance schedule in the operator's manual.

The user is responsible for inspecting his machine and for having parts repaired or replaced when continued use of the product would cause damage or excessive wear to the other parts.

It is the user's responsibility to deliver his machine to the Yetter dealer who sold him the product for service or replacement of defective parts, which are covered by the warranty policy.

If you are unable to understand or follow the instructions provided in this publication, consult your local Yetter dealer or contact:

## YETTER MANUFACTURING CO.

309/776-4111

800/447-5777

309/776-3222 (FAX)

Website: [www.yetterco.com](http://www.yetterco.com)

E-mail: [info@yetterco.com](mailto:info@yetterco.com)

## WARRANTY

Yetter Manufacturing warrants all products manufactured and sold by it against defects in material. This warranty being expressly limited to replacement at the factory of such parts or products as shall appear to be defective after inspection. This warranty does not obligate the Company to bear cost of labor in replacement of parts. It is the policy of the Company to make improvements without incurring obligations to add them to any unit already sold. No warranty is made or authorized to be made, other than herein set forth. This warranty is in effect for one year after purchase.

DEALER: \_\_\_\_\_

**Yetter Manufacturing warrants its own products only and cannot be responsible for damages to equipment on which mounted.**



## SAFETY PRECAUTIONS



A brief description of signal words that may be used in this manual:

**DANGER**: Indicates an imminently hazardous situation which, if not avoided “will” result in death or serious injury. This signal word is to be limited to the most extreme situations.

**WARNING**: Indicates a potentially hazardous situation which, if not avoided, “could” result in death or serious injury.

**CAUTION**: Indicates a potentially hazardous situation, which if not avoided, “may” result in minor or moderate injury. It may also be used to alert against unsafe practices.

**NOTICE**: Indicates information considered important, but not hazard related (e.g., messages relating to property damage).

Consult your implement and tractor operator’s manual for correct and safe operating practices. Be aware of towed implement width and allow safe clearance.

Safety decals are placed on the implement to alert the operator and others to the risk of personal injury or unsafe operation during normal operations and servicing.

1. The safety decals must be kept clean and in good condition to ensure that they are legible.
2. Safety decals must be replaced if they are missing or illegible.
3. When components are replaced during repair or servicing, check that the new components include the necessary safety signs.
4. Replacement safety decals may be obtained from your local dealer.



### WARNING

Read these instructions carefully to acquaint yourself with the Equipment. Working with unfamiliar equipment can lead to accidents.

Never park the equipment on a steep incline or leave the equipment running unattended.

Never clean, lubricate or adjust a machine that is in motion.

Always check that straps are secure.

Make sure latches are in pinned position when moving equipment.

Do not allow children to operate this equipment.

Do not allow riders on the equipment, trailer and/or pick-up.

Use speed and caution dictated by the terrain being traversed. Do not operate on any slope steep enough to cause tipping or loss of control.

Read and understand the operator’s manual and require all other persons who will operate the equipment to do the same.

If operating on public roadways, where legal, be certain all lighting is operating properly and observe all traffic laws.

Beware of increased stopping distances and control effort when operating with implements attached.

Be familiar with all controls and be prepared to stop equipment quickly in an emergency.

**FAILURE TO HEED MAY RESULT IN PERSONAL INJURY OR DEATH.**

# YETTER MODEL 2995 GENERATION III COULTER

- 2995-012 – FERTILIZER COULTER ASSEMBLY, RH**  
**2995-012-L – FERTILIZER COULTER ASSEMBLY, LH**  
**2995-140 – COULTER ASSEMBLY, RH**  
**2995-140-L – COULTER ASSEMBLY, LH**

## CLAMPS

(DIMENSIONS ARE INCHES HORIZONTAL X VERTICAL)

<i>Part No.</i>	<i>Description</i>
2975-151	Clamp Kit, 3 X 6 Bar
2990-153	Clamp Kit, 2" Sq. Bar
2990-154	Clamp Kit, 2 1/2" Sq. Bar
2990-155	Clamp Kit, 2 x 6 Bar
2990-156	Clamp Kit, 4 x 4 Bar
2990-157	Clamp Kit, 5 x 7 Bar
2990-158	Clamp Kit, 7 x 7 Bar
2990-159	Clamp Kit, 3" Dmd Bar
2990-160	Clamp Kit, 3 1/2" Dmd Bar
2990-161	Clamp Kit, 3 x 7 Bar
2990-162	Clamp Kit, 2 1/2" Sq., 1/2" Spacer
2990-163	Clamp Kit, 3" Sq. Bar
2990-166	Clamp Kit, 2 1/4", 2 1/2" Dmd Bar
2990-171	Clamp Kit, 3 x 4 Bar
2990-172	Clamp Kit, 4 x 6 Bar
2990-173	Clamp Kit, 6 x 4 Bar
2990-174	Clamp Kit, 7 x 5 Bar
2990-175	Clamp Kit, 7 x 4 Bar
2990-181	Clamp Kit, 4 x 10 Special
2990-182	Clamp Kit, 4 x 7 Bar
2999-120	Clamp, Air Seeder
6300-105	Clamp Kit, 5 x 5 Bar

## SHANKS

(TOTAL LENGTH OF SHANK IN INCHES)

<i>Part No.</i>	<i>Description</i>
2990-208	Shank, 12 5/8" Long, 3" Offset
2990-221	Shank, 27" Long, 3" Offset
2990-310	Shank, 12 5/8"
2990-318	Shank, 16"
2990-328	Shank, 26"
2990-342	Shank, 18" Long, 3/4" Offset
2990-350	Shank, 27 1/8"
2990-353	Shank, 22" Long, 3/4" Offset
2990-354	Shank, 18" Long, 5 1/2" Offset
2990-370	Shank, 30" Long, Straight
2990-377	Shank, 15" Long, 5 1/2" Offset
3010-303	Shank, 22", Straight
3011-302	Shank, 22" Long, 5 1/2" Offset
6300-331	Shank, 19" Long, 3/4" Offset

## FERTILIZER KNIVES

### 17" BLADE

Dry Fertilizer Knife	2975-116
Liquid Fertilizer Knife	2975-220
Suspension Rear Fertilizer Knife	2975-219
Seeder Knife	2977-203
Liquid Side Knife, Left	2995-122
Liquid Side Knife, Right	2995-123
Dry Side Knife, Left	2995-124
Dry Side Knife, Right	2995-125

### 20" BLADE

2996-201	Dry Knife
2996-200	Liquid Knife
2996-203	Liquid Suspension Knife
2996-114	Liquid Side Knife, Left
2996-115	Liquid Side Knife, Right
2996-116	Dry Side Knife, Left
2996-117	Dry Side Knife, Right

Spring Mount Liquid Fertilizer Injection Kit – 2995-109 – For 17" and 20"

Spring Mount Dry Fertilizer Injection Kit – 2995-130 – For 17" and 20"

## BLADES

PART NO.	DESCRIPTION	PART NO.	DESCRIPTION
2571-164	14-5/8" Wave Blade (8 Wave)	2571-156	18" Wavy Blade (8 Wave)
2571-166	14-5/8" 25 Multi-Wave Blade	2571-155	18" 13 Wave Blade
2571-153	16" Bubble Flute Blade	2571-179	18" Multi-Wave Blade (25 Wave)
2571-161	16" Ripple Blade	2571-169	18" Smooth Blade
2571-156	16" Wavy Blade (8 Wave)	2571-076	20" Ripple Blade
2571-162	16" 13 Wave Blade	2571-178	20" Smooth Blade
2571-172	16" Multi-Wave Blade (25 Wave)	2571-198	20" Notched Blade
2571-206	16" Smooth Blade	2571-201	20" Notched Bubble Blade
2571-158	17" Ripple Blade	2571-202	20" Multi-Wave Blade (25 Wave)
2571-165	17" Notched Smooth Blade	2571-196	22" Smooth Blade-(Cutting Coulter Only)

## OPTIONAL EQUIPMENT

2975-120	Gauge Wheel Kit	6200-107	V-Close Wheel Kit
2970-133	Knife Scraper 17"	2920-022	Press Wheel Kit
2976-133	Knife Scraper 20"	2920-021	16" Disc Sealer

# SINGLE ARM COULTERS

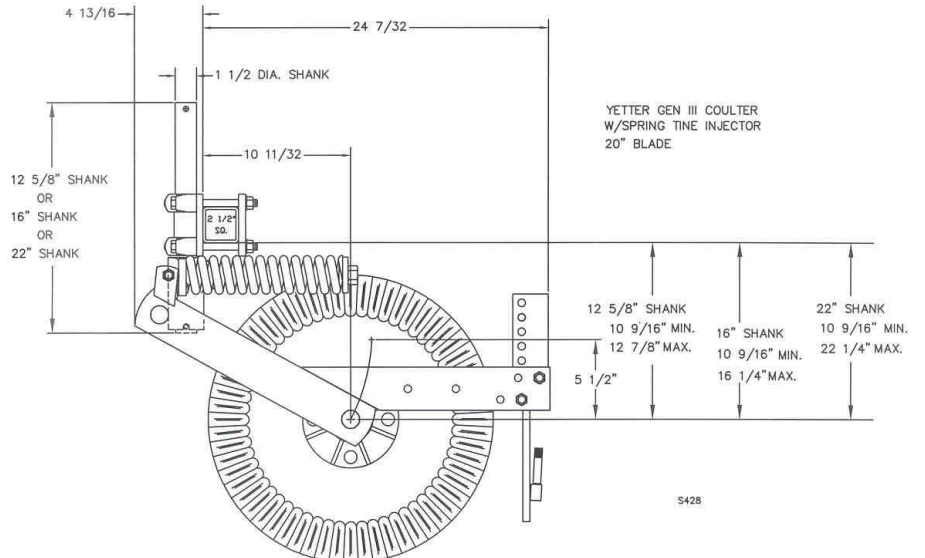
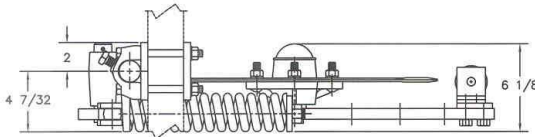
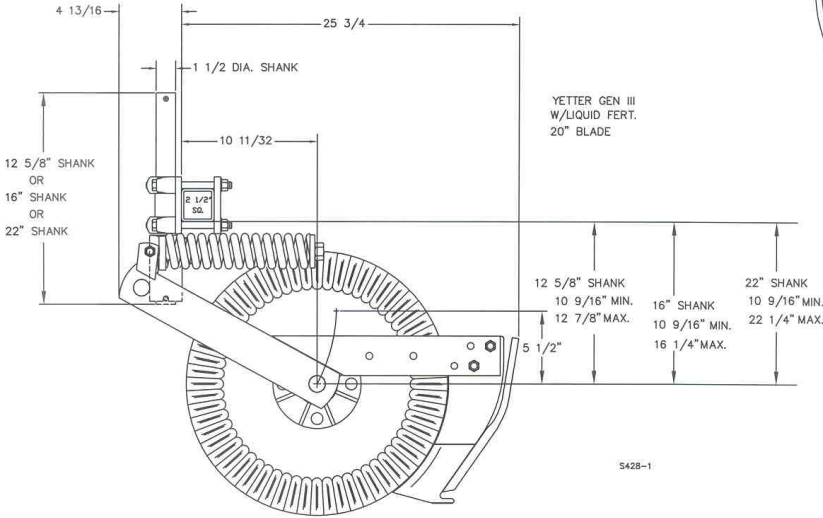
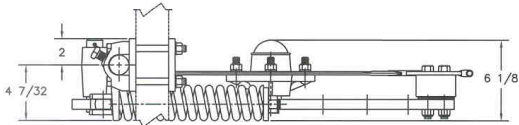
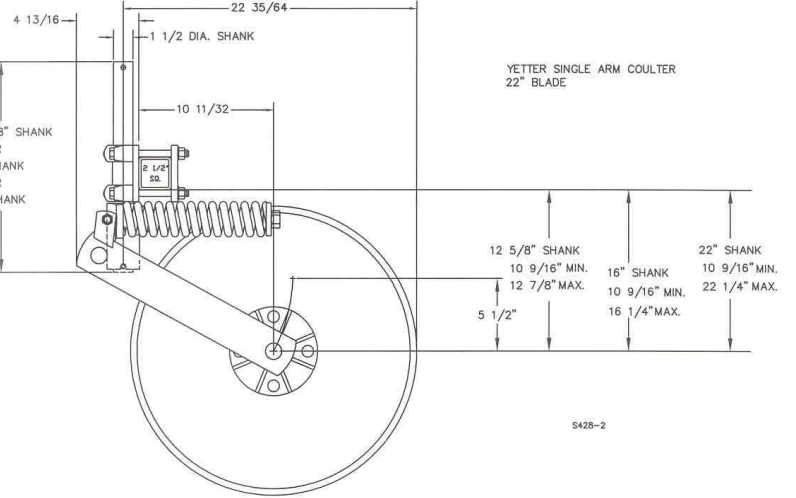
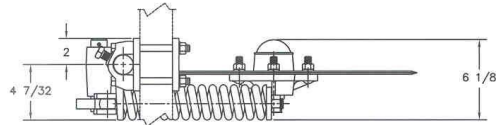

## INSTALLATION

1. Assembly 3/8 x 2-1/2" roll pin into hole closest to end of 1-1/2" diameter shank, leaving approximately equal amount protruding out each side. Note: offset shanks require that you perform step 2 first then step 1.
2. Insert lock collar into pivot casting and slide shank up through casting and lock collar. If you wish to lock coulters from pivoting, slide roll pin into slots in casting. If you wish to let coulters pivot, do not align roll pin with casting slots, but slide shank up till roll pin contacts casting surface. Install and tighten 5/8 x 1" setscrew in lock collar to 110 ft. lb. torque maximum.
3. Mount 17" blade loosely to hub using four 1/2 x 1-1/2" carriage bolts, lock washers and nuts.
4. Mount fertilizer knife and spacer block to rear support arm using two 1/2 bolts lock nuts. Place shims between 2995-309 – Spacer Block and support arm as required to align knife point with blade.
5. **Center blade on hub** by rotating blade and watching clearance between knife and blade. Slide blade on hub as required until clearance varies no more than 1/8" when blade is rotated one complete revolution. Tighten four 1/2" nuts. If blade-wobble is excessive, check for burrs on hub mounting surface and remove if necessary.
6. Adjust knife clearance to blade **as close as possible**. The high point of the blade should **just** clear the knife as blade is rotated. Be sure blade rotates freely then tighten two 1/2" locknuts to 120 ft. lb. Re-check clearance, by rotating blade one full revolution, after all bolts are tightened.
7. Assemble clamp components loosely to planter front bar as shown in parts view of appropriate clamp.
8. Position coulters clamps either toward the inside or outside of the planter openers on each side of the planter to equalize draft. Tighten four 1/2" nuts to secure the clamps.
9. Install coulters on planter by inserting shank up through clamps and tightening 5/8 x 1" setscrews.
10. Install 5/16 x 2-1/2" cotter pins in all vertical 1-1/2" diameter shanks. This cotter pin prevents loss of coulters should the clamp setscrews work loose. Cotter pin can be installed between clamp castings or on top, above top casting depending on the shank.
11. Set coulters depth by loosening setscrews in clamp castings. For John Deere 7000 front fold planters there may not be enough up adjustment to operate coulters at proper depth, not more than hub deep. Not all toolbars on John Deere planters operate at the same height. If necessary, cut off top of 1/12" diameter shank to allow proper adjustment.

## INSTALLATION

12. On John Deere 7000 front fold planters there are two hoses that may interfere with coulter operation. Loosen hydraulic fittings and swivel hoses up out of the way to provide clearance when coulter flexes up.
13. If you have elected to let coulter swivel, set lock collar to allow swivel in one or both directions as required. If you have elected to hold coulter rigid, set coulter straight with the direction of travel. Tighten set screw to 110 ft. lb. torque maximum.
14. Set spring tension by adjusting 3/4" lock nut until 1/8" of threads are exposed above the nut. Tighten 3/4" locknut if greater spring pre-load is required. NOTE: This will reduce vertical movement of coulter.
15. **NEVER** mount coulters under planter drive shaft to allow coulter blades to contact shaft when an obstacle is struck. Coulters must be mounted so blade can always flex up and clear drive shaft.

**Dry fertilizer must be free of chunks greater than 1/4" in size to prevent plugging. Yetter recommends using screened fertilizer or running fertilizer through screen when hoppers are filled. Clean hoppers thoroughly at the beginning of season to prevent plugging problems.**

**The rubber dry fertilizer tube may appear to be 'stretched' when the planter is in the transport position. This does not affect operation of the planter and should not be detrimental to the fertilizer tube.**

## OPERATION

Yetter Model Generation III fertilizer coulters are designed to apply fertilizer 3" to 5" deep. See your fertilizer dealer for recommended depth and distance away from row for your particular fertilizer. A popular placement setting is 2" below and 2" away from the seed. High deposit rates require the fertilizer to be placed farther away from the row to avoid crop "burn".

The coulter can be set up to swivel or not swivel as required. By not allowing the coulter to swivel, the distance between seed and fertilizer varies less when planting on contour.

When mounting Model Generation III coulters on 3-point or 2-point hitch planters, the coulters should be set up to swivel, particularly if a 4-wheel drive tractor is used. This reduces the side load on the coulter during operation. It is preferable to allow the coulter to swivel.



**NOTICE: For proper operation, the planter frame must operate level and at the correct height, usually 20" – 22" while in operation.**

In hard no-till conditions the desired operating depth may not be possible. Tighten spring nut to maintain depth if spring is flexing rather than lower coulter to obtain maximum depth.

Planter weight may limit operating depth in hard conditions, particularly with mounted or semi-mounted planters. Be sure planter has enough weight to keep drive wheels on the ground during operation or plant populations can be drastically affected.

# OPERATION

1. Set coulters blades to run vertical to ground. Operation depth and blade wear can be affected if coulter is mounted crooked. If coulters are set-up to not swivel be sure they run straight with the direction of travel.
2. After a few hours use, check all bolts and setscrews for tightness.
3. After a few days use, check coulter hubs for loose bearings. There should be no end play in the hub bearings to allow it to wobble. If necessary, remove hub cap and cotter pin, adjust slotted nut to remove wobble, re-insert cotter pin and replace hub cap.
4. **KNIFE ADJUSTMENT IS CRITICAL.** Adjust knife-blade clearance regularly, see page 9.

An optional knife scraper, Part #2970-133 or 2976-133 is available to reduce the frequency of adjustment on the fertilizer coulter knife. In addition this allows better operation in tough conditions such as freshly disked soils with abundant trash in the top four inches of loose soil.

A 'bump' will appear behind knife scraper, on blade where protected, this must be ground off periodically to maintain correct knife-blade clearance.

5. **BLADE WEAR** can affect operation in loose trash conditions. If knife adjustment does not stop plugging problems, it may be necessary to replace blade.
6. **Dry fertilizer must be free of chunks greater that 1/4" in size to prevent plugging. Yetter recommends using screened fertilizer or running fertilizer through screen when hoppers are filled. Clean hoppers thoroughly at the beginning of season to prevent plugging problems.**

**The rubber dry fertilizer tube may appear to be 'stretched' when the planter is in the transport position. This does not affect operation of the planter and should not be detrimental to the fertilizer tube.**

**2970-133 17" Knife Scraper**

Key	Qty.	Part No.	Description
1	1	2970-353	Double Edge Knife Scraper
2	1	2502-199	5/16-18 x 3/4 HHCS Gr. 5 ZP
3	1	2526-201	5/16 Std. Flat washer ZP
4	1	2520-205	5/16-18 Lock Hex Nut ZP

**2976-133 20" Knife Scraper**

Key	Qty.	Part No.	Description
1	1	2976-353	Double Edge Knife Scraper
2	1	2502-199	5/16-18 x 3/4 HHCS Gr. 5 ZP
3	1	2526-201	5/16 Std. Flat washer ZP
4	1	2520-205	5/16-18 Lock Hex Nut ZP

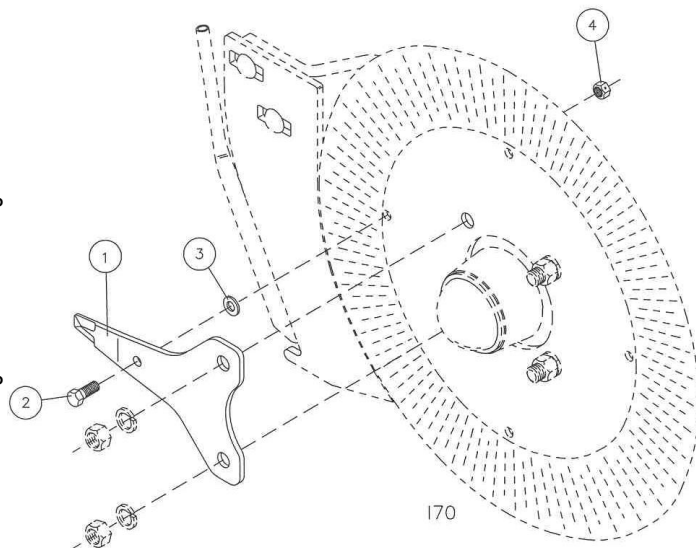



# MAINTENANCE

## LUBRICATION



**DANGER:** Always install safety lock-ups or lower the planter to the ground before working on the machine. Lubricate at frequency indicated with a multi-purpose type grease.

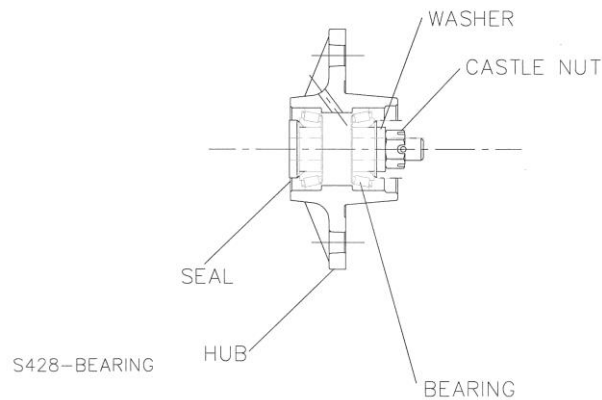
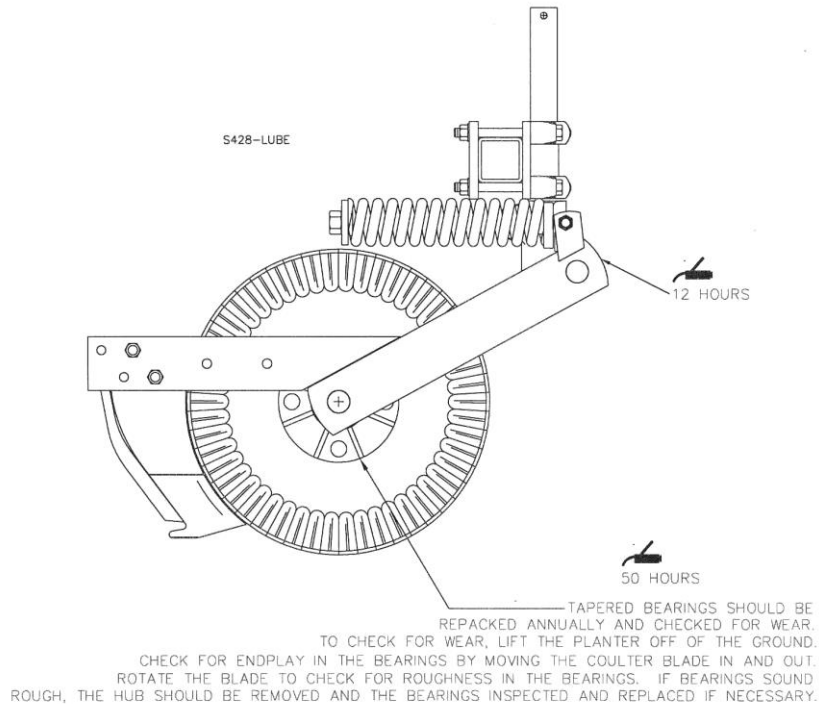

**DANGER:** Always install all safety lock-ups and safety lock pins before working under the toolbar.

1. Raise the toolbar until it is clear off the ground. Remove the gauge wheel and the blade. Remove the hubcap, cotter pin, slotted nut and washer from the spindle shaft assembly.
2. Pull the coultter spindle shaft assembly from the hub. Remove bearing cones and cups and discard if bearings are being replaced. Clean hub and dry. Remove bearings only and not cups of re-packing.
3. Wash the old grease from the hub, bearing cups, coultter spindle shaft, seal, and bearing cones. Inspect the condition of bearing cups and cones.
4. Apply #2 multi-purpose lithium grease on each bearing. Make sure the space around each roller is filled. Lubricate the bearing cups.
5. Position the bearing in the cup and install the seal. Lubricate the seal lips and proceed with re-assembly of the removed parts including the blade. Blade bolt torque is 90 to 96 ft. lbs.
6. Install outer bearing, washer, and slotted nut. Tighten the slotted nut to 150 in. lbs. while rotating the blade or until a definite drag is felt when the blade is turned by hand. Tighten the nut one slot position to line up the cotter pin hole with a slot. Secure the nut with a new cotter pin.

## KNIFE ADJUSTMENT

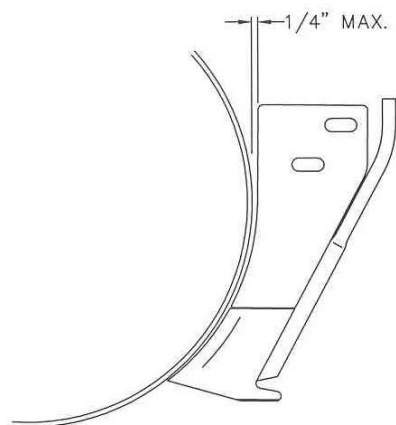

CORRECT

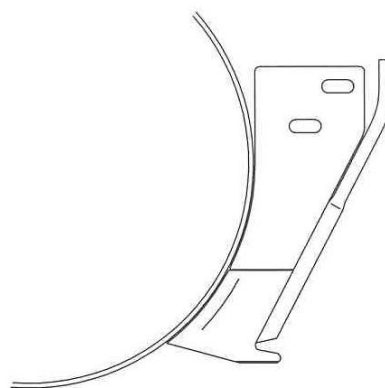

CORRECT

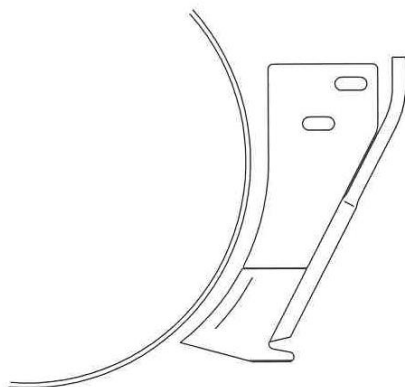

INCORRECT

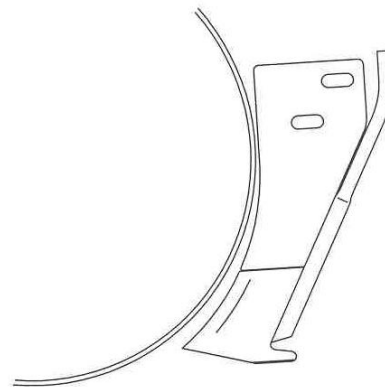

INCORRECT

S 286

The adjustment of knife clearance to the blade is critical to trouble free operation of the fertilizer coupler, in certain conditions the coupler can "plug" in just a few feet if not correctly adjusted.

1. The disc blade **must** run concentric. Adjust by loosening four hub nuts and centering the blade.
2. Set knife to rub slightly on blade, especially at bottom of knife. See illustrations above. Tighten lock nuts securely.

# PARTS IDENTIFICATION

2995-020 - GEN III KNIFE ARM COULTER, 20"  
 2995-017 - GEN III KNIFE ARM COULTER, 17"

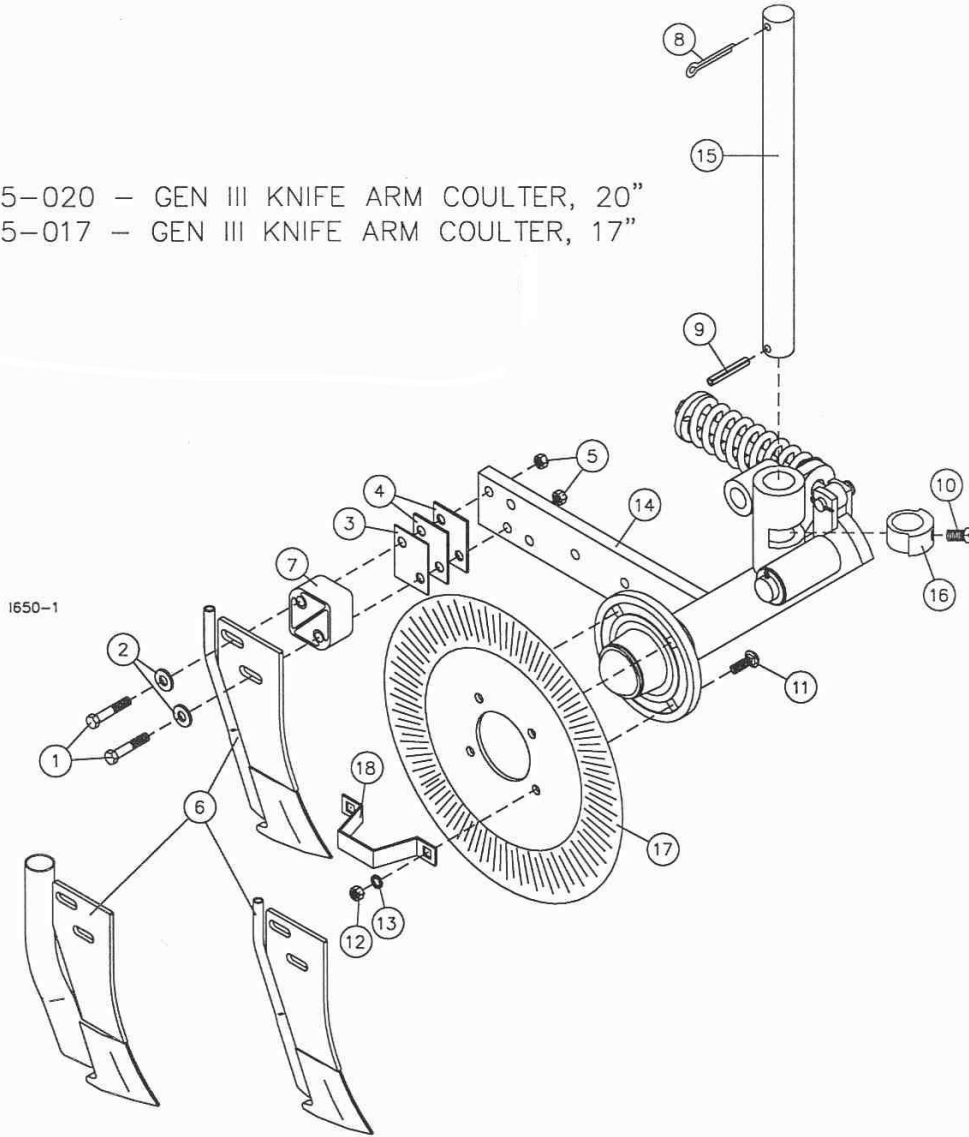

DET.	QTY.	PART NO.	DESCRIPTION	DET.	QTY.	PART NO.	DESCRIPTION
1	2	2502-358	1/2-13 X 3 1/2 HHCS GR 8, Z	9	1	2530-208	3/8 X 2-1/2 ROLL PIN ZP
2	2	2526-355	1/2 FLAT WASHER, HARD'ND, P	10	1	2503-379	5/8-11 X 1 SQ. HCPSS GR.5 Z
3	1	2970-320	KNIFE SHIM, 16 GA., ZP.	11	4	2505-337	1/2-13 X 1-1/4 CAR BLT GR 5
4	2	2970-319	KNIFE SHIM, 1/8", ZP.	12	4	2520-352	1/2-13 HEX NUT ZP
5	2	2520-362	1/2-13 HEX NIF-LOK NUT, ZP	13	4	2525-352	1/2 MED LOCKWASHER ZP
6	1	2975-220	LIQUID FERTILIZER KNIFE W.A.	14	1	2995-012	GEN III CLTR W/KNIFE ARM ASS'Y
	1	2975-116	DRY FERTILIZER KNIFE ASSEMBLY	15	1	2990-350	SHANK, 1-1/2 X 27-1/8 INCH
	1	2975-219	SUSPENSION KNIFE W.A.	16	1	2975-303	2975 LOCKING COLLAR
	1	2977-203	SEEDER KNIFE W.A.	17	1	2571-165	.157 X 17" NOTCH COULT. BLADE
	1	2996-201	20" DRY FERTILIZER KNIFE,W.A.		1	2571-158	.157 X 17" RIPPLE BLADE
	1	2996-200	20" LIQUID FERT KNIFE W.A.		1	2571-179	.157 X 17.63" 25 FLUTE BLADE
	1	2996-203	20" SUSPENSION FERT KNIFE W.A.		1	2571-169	.25 X 18 STRAIGHT BLADE W/SQHOLE
7	1	2995-309	SPACER BLOCK, 1.531"		1	2571-076	.157 X 20" RIPPLE BLADE
8	1	2531-161	5/16 X 2-1/2 COTTER PIN ZP		1	2571-178	.25 X 20 STRAIGHT BLADE W/SQHOLE
					1	2571-198	.157 X 20" MULTI HOLE NOTCH BLADE
				18	1	2987-301	HUB CAP RETAINER

# PARTS IDENTIFICATION

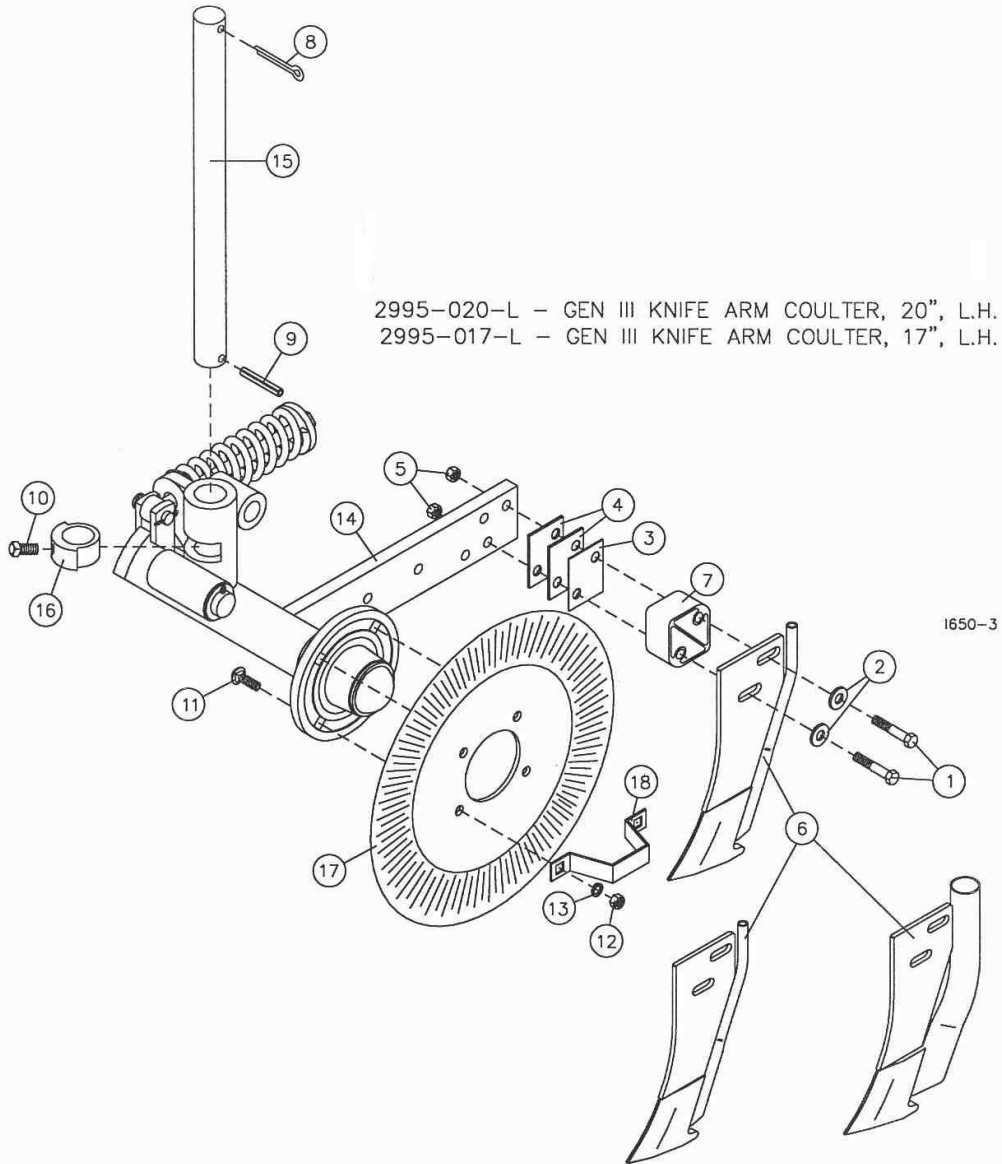

DET.	QTY.	PART NO.	DESCRIPTION	DET.	QTY.	PART NO.	DESCRIPTION
1	2	2502-358	1/2-13 X 3 1/2 HHCS GR 8, Z	9	1	2530-208	3/8 X 2-1/2 ROLL PIN ZP
2	2	2526-355	1/2 FLAT WASHER, HARD'ND, P	10	1	2503-379	5/8-11 X 1 SQ. HCPSS GR.5 Z
3	1	2970-320	KNIFE SHIM, 16 GA., ZP.	11	4	2505-337	1/2-13 X 1-1/4 CAR BLT GR 5
4	2	2970-319	KNIFE SHIM, 1/8", ZP.	12	4	2520-352	1/2-13 HEX NUT ZP
5	2	2520-362	1/2-13 HEX NIF-LOK NUT, ZP	13	4	2525-352	1/2 MED LOCKWASHER ZP
6	1	2975-220	LIQUID FERTILIZER KNIFE W.A.	14	1	2995-012-L	GEN III CLTR W/KNIFE ARM ASS'Y, L.H.
	1	2975-116	DRY FERTILIZER KNIFE ASSEMBLY	15	1	2990-350	SHANK, 1-1/2 X 27-1/8 INCH
	1	2975-219	SUSPENSION KNIFE W.A.	16	1	2975-303	2975 LOCKING COLLAR
	1	2977-203	SEEDER KNIFE W.A.	17	1	2571-165	.157 X 17" NOTCH COULT. BLADE
	1	2996-201	20" DRY FERTILIZER KNIFE W.A.		1	2571-158	.157 X 17" RIPPLE BLADE
	1	2996-200	20" LIQUID FERT KNIFE W.A.		1	2571-179	.157 X 17.63" 25 FLUTE BLADE
	1	2996-203	20" SUSPENSION FERT KNIFE W.A.		1	2571-169	.25 X 18 STRAIGHT BLADE W/SQHOLE
7	1	2995-309	SPACER BLOCK, 1.531"		1	2571-076	.157 X 20" RIPPLE BLADE
8	1	2531-161	5/16 X 2-1/2 COTTER PIN ZP		1	2571-178	.25 X 20 STRAIGHT BLADE W/SQHOLE
					1	2571-198	.157 X 20" MULTI HOLE NOTCH BLADE
				18	1	2987-301	HUB CAP RETAINER

# PARTS IDENTIFICATION

2995-018 GEN III COULTER W/INJ., 17"/20"

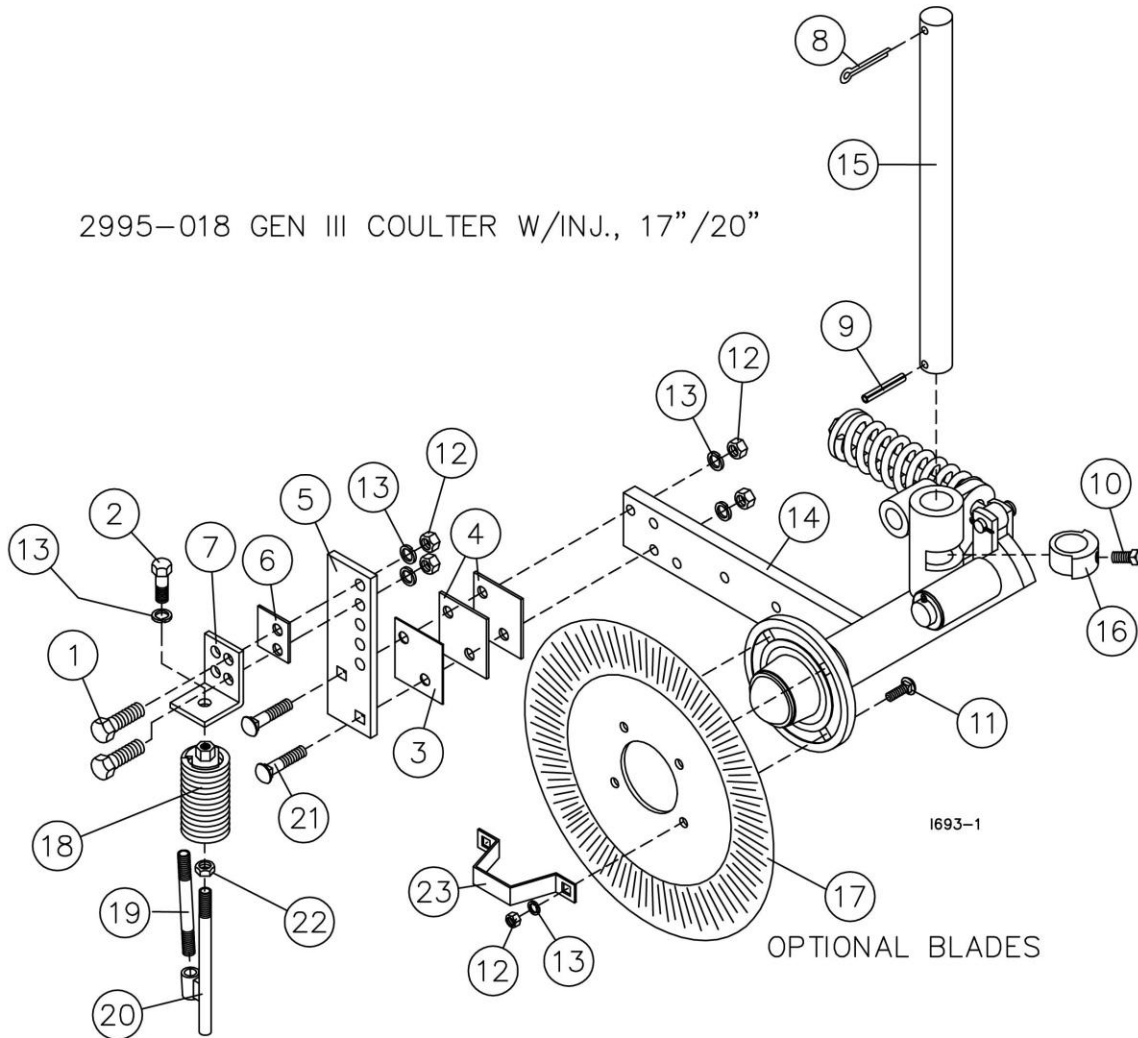

DET.	QTY.	PART NO.	DESCRIPTION	DET.	QTY.	PART NO.	DESCRIPTION
1	2	2502-294	1/2-13 X 1-1/2 HHCS GR5 YD	15	1	2990-350	SHANK, 1-1/2 X 27-1/8 INCH
2	1	2502-292	1/2-13 X 1 HHCS GR. 5 ZP	16	1	2975-303	2975 LOCKING COLLAR
3	1	2970-320	KNIFE SHIM, 16 GA., ZP.	17	1	2571-158	.157 X 17" RIPPLE BLADE
4	2	2970-319	KNIFE SHIM, 1/8", ZP.	1	1	2571-179	.157 X 17.63" 25 FLUTE BLADE
5	2	2975-389	ADJUSTMENT PLATE, INJECTOR	1	1	2571-076	.157 X 20" RIPPLE BLADE
6	1	2995-320	SPACER, INJECTOR	1	1	2571-202	.157 X 19.94" 25 WAVE BLADE
7	1	2995-301	INJECTOR MOUNT PLATE	18	1	2995-131	SPRING INJECTOR ASSEMBLY
8	1	2531-161	5/16 X 2-1/2 COTTER PIN ZP	19	1	2515-311	3" NIPPLE, 1/4 NPT STAINLESS STL
9	1	2530-208	3/8 X 2-1/2 ROLL PIN ZP	20	1	2995-212	INJECTOR ROD W.A., 1/2-13
10	1	2503-379	5/8-11 X 1 SQ. HCPSS GR.5 Z	21	2	2505-345	1/2-13 X 2 CAR BLT GR5 ZP
11	4	2505-337	1/2-13 X 1-1/4 CAR BLT GR 5	22	1	2520-356	1/2-13 JAM HEX NUT ZP
12	8	2520-352	1/2-13 HEX NUT ZP	23	1	2987-301	HUB CAP RETAINER
13	9	2525-352	1/2 MED LOCKWASHER ZP				
14	1	2995-012	GEN III CLTR W/KNIFE ARM ASS'Y				

**PARTS IDENTIFICATION**  
**2995-012 GEN III FERTILIZER COULTER RIGHT HAND (SHOWN)**  
**2995-012-L GEN III FERTILIZER COULTER LEFT HAND**

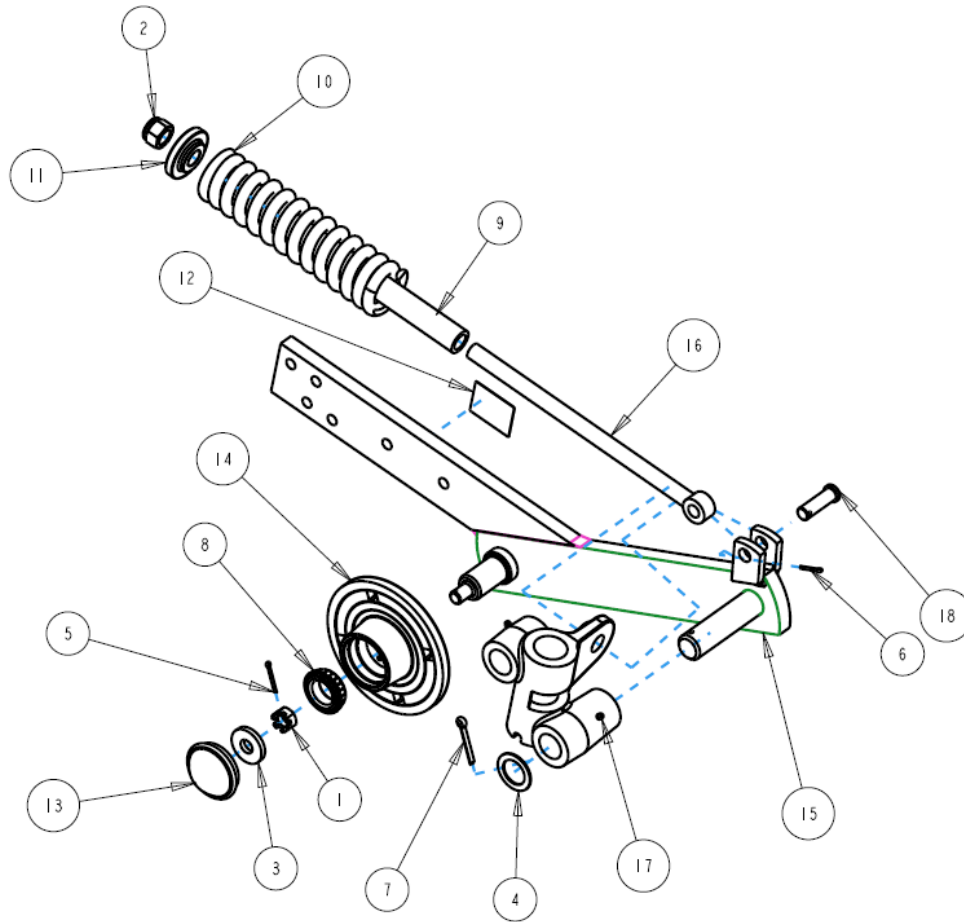

DET	PART NO.	DESCRIPTION	QTY
1	2520-469	5/8-18 SLOTTED HEX NUT	1
2	2520-516	3/4-10 NYLON LOCKNUT	1
3	2526-449	5/8" FLATWASHER 1/4" THICK	1
4	2526-561	1-17/64" ID X 1-7/8" OD WASHER	1
5	2531-102	1/8" X 1-1/4" COTTER PIN	1
6	2531-107	1/8" X 1" COTTER PIN	1
7	2531-125	1/4" X 1-3/4" COTTER PIN	1
8	2550-027	BEARING CONE LM67048	1
9	2550-771	HELPER SPRING	1
10	2550-795	SPRING	1
11	2975-302	SPRING BUSHING	1
12	2565-682	DECAL	1
13	2570-375	CAP	1
14	2900-102	HUB ASSEMBLY	1
	2550-027	BEARING CONE LM67048	1
	2550-066	TRIPLE LIP SEAL	1
	2900-105	HUB WITH BEARING CUPS	1
	2533-110	1/4-28 GREASE FITTING	1
	2550-029	BEARING CUPS LM67010	2
15	2995-214	FERTILIZER ARM RIGHT HAND (SHOWN)	1
	2995-224	FERTILIZER ARM LEFT HAND	1
16	2995-304	SPRING ROD	1
17	2995-307	COULTER PIVOT RIGHT HAND (SHOWN)	1
	2995-306	COULTER PIVOT LEFT HAND	1
18	2995-308	PIN	1

**PARTS IDENTIFICATION**  
**2995-140 COULTER ASSEMBLY RIGHT HAND (SHOWN)**  
**2995-140-L COULTER ASSEMBLY LEFT HAND**

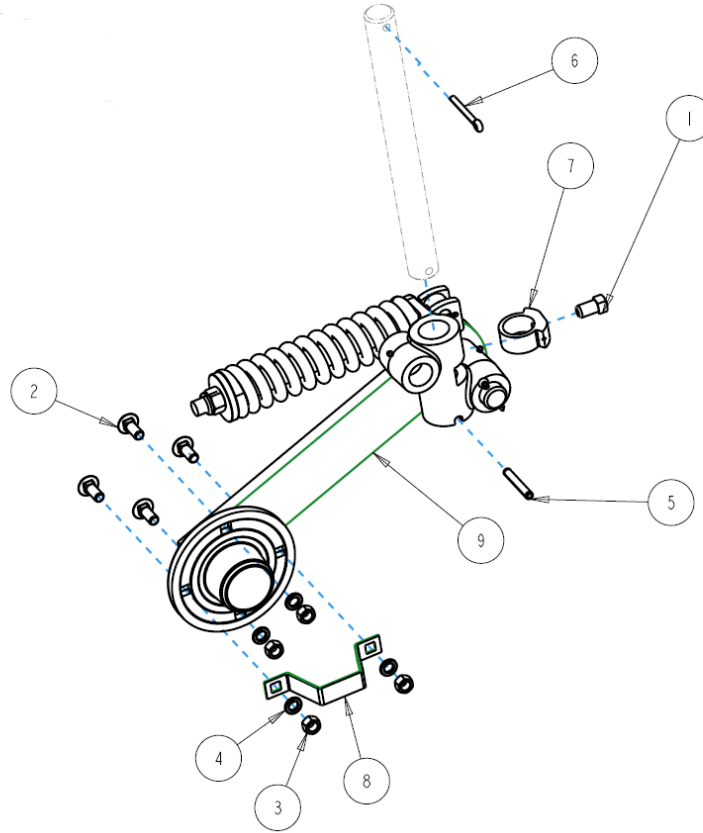

DET	PART NO.	DESCRIPTION	QTY
1	2503-379	5/8-11 X 1" SET SCREW GR 5	1
2	2505-337	1/2-13 X 1-1/4" CARRIAGE BOLT GR 5	4
3	2520-352	1/2-13 HEX NUT	4
4	2525-352	1/2" LOCKWASHER	4
5	2530-208	3/8" X 2-1/2" ROLL PIN	1
6	2531-161	5/16" X 2-1/2" COTTER PIN	1
7	2975-303	LOCKING COLLAR	1
8	2987-301	HUB CAP RETAINER	1
9	2995-142	COULTER ASSEMBLY RIGHT HAND (SHOWN)	1
	2995-143	COULTER ASSEMBLY LEFT HAND	1

**BLADE OPTIONS**

PART NO.	DESCRIPTION
2571-155	18" 13 WAVE
2571-156	16" 8 WAVE
2571-158	17" RIPPLE
2571-161	16" RIPPLE
2571-162	16" 13 WAVE
2571-165	17" NOTCHED SMOOTH
2571-169	18" SMOOTH
2571-172	16" 25 WAVE
2571-178	20" SMOOTH
2571-179	18" 25 WAVE
2571-198	20" NOTCHED SMOOTH
2571-278	20" 25 WAVE

**PARTS IDENTIFICATION**  
**2995-142 COULTER ASSEMBLY RIGHT HAND (SHOWN)**  
**2995-143 COULTER ASSEMBLY LEFT HAND**

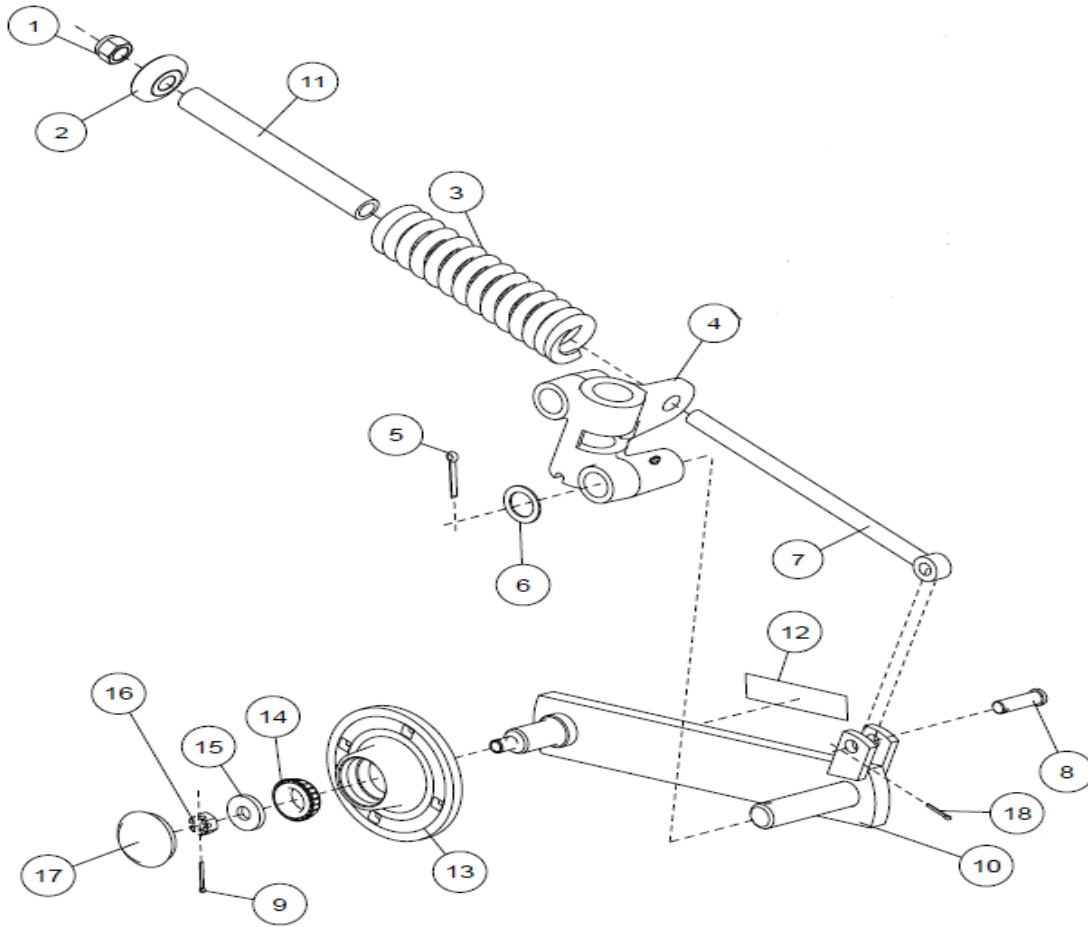

DET	PART NO.	DESCRIPTION	QTY
1	2520-516	¾-10 NYLON LOCKNUT	1
2	2975-302	SPRING BUSHING	1
3	2550-795	SPRING	1
4	2995-307	COULTER PIVOT RIGHT HAND (SHOWN)	1
	2995-306	COULTER PIVOT LEFT HAND	1
5	2531-125	¼ X 1-3/4" COTTER PIN	1
6	2526-561	1-17/64" ID X 1-7/8" OD WASHER	1
7	2995-304	SPRING ROD	1
8	2995-308	PIN	1
9	2531-102	1/8" X 1-1/4" COTTER PIN	1
10	2995-210	ARM RIGHT HAND (SHOWN)	1
	2995-222	ARM LEFT HAND	1
11	2550-771	HELPER SPRING	1
12	2565-162	DECAL	1
13	2900-102	HUB ASSEMBLY	1
	2550-027	BEARING CONE LM 67048	1
	2550-066	TRIPLE LIP SEAL	1
	2550-029	BEARING CUP LM 67010	2
	2900-105	HUB INCLUDES CUPS	1
14	2550-027	BEARING CONE LM 67048	1
15	2526-449	5/8" FLAT WASHER ¼" THICK	1
16	2520-469	5/8"-18 SLOTTED HEX NUT	1
17	2570-375	CAP	1
18	2531-107	1/8" X 1" COTTER PIN	1



## PARTS IDENTIFICATION

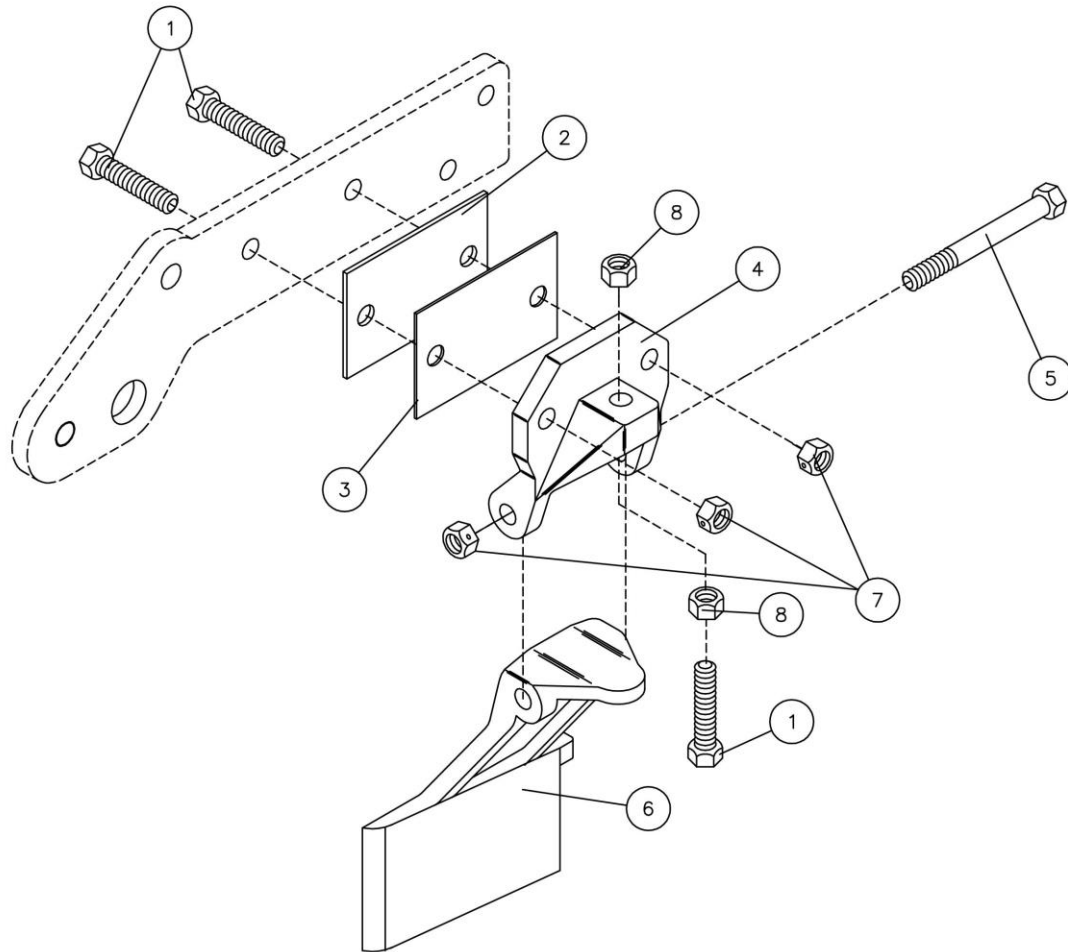

## SIDE KNIFE KITS

2995-122 Liquid Side Knife Assy., L.H.      2995-124 Dry Side Knife Assy., L.H.  
 2995-123 Liquid Side Knife Assy., R.H.      2995-125 Dry Side Knife Assy., R.H.  
 To be used with 2571-165 or 2571-169 blades only.

2996-114 LH 5-1/2" Liq Side Knife Assy.      2996-116 LH 5-1/2" Dry Side Knife Assy.  
 2996-115 RH 5-1/2" Liq Side Knife Assy.      2996-117 RH 5-1/2" Dry Side Knife Assy.  
 To be used with 2571-178 blade only.

Key	Qty.	Part No.	Description
1	3	2502-351	1/2-13 x 2 HHCS Gr. 5 ZP
2	1	2995-316	Side Knife Shim, 1/8", ZP
3	3	2995-315	Side Knife Shim, 16 Ga., ZP
4	1	2995-314	Side Knife Brkt., 2995
5	1	2502-362	1/2-13 x 5 HHCS Gr. 5 ZP
6	1	2995-121	Liquid Side Knife Assy., R.H. (Shown)
	1	2995-120	Liquid Side Knife Assy., L.H.
	1	2995-200	Dry Side Knife W.A., L.H.
	1	2995-201	Dry Side Knife W.A., R.H.
	1	3000-123	LH 5-1/2" Liq Side Knife S.A.
	1	3000-124	RH 5-1/2" Liq Side Knife S.A.
	1	3000-234	LH 5-1/2" Dry Side Knife W.A.
	1	3000-235	RH 5-1/2" Dry Side Knife W.A.
7	3	2520-357	1/2-13 Lock Hex Nut ZP

### PARTS IDENTIFICATION

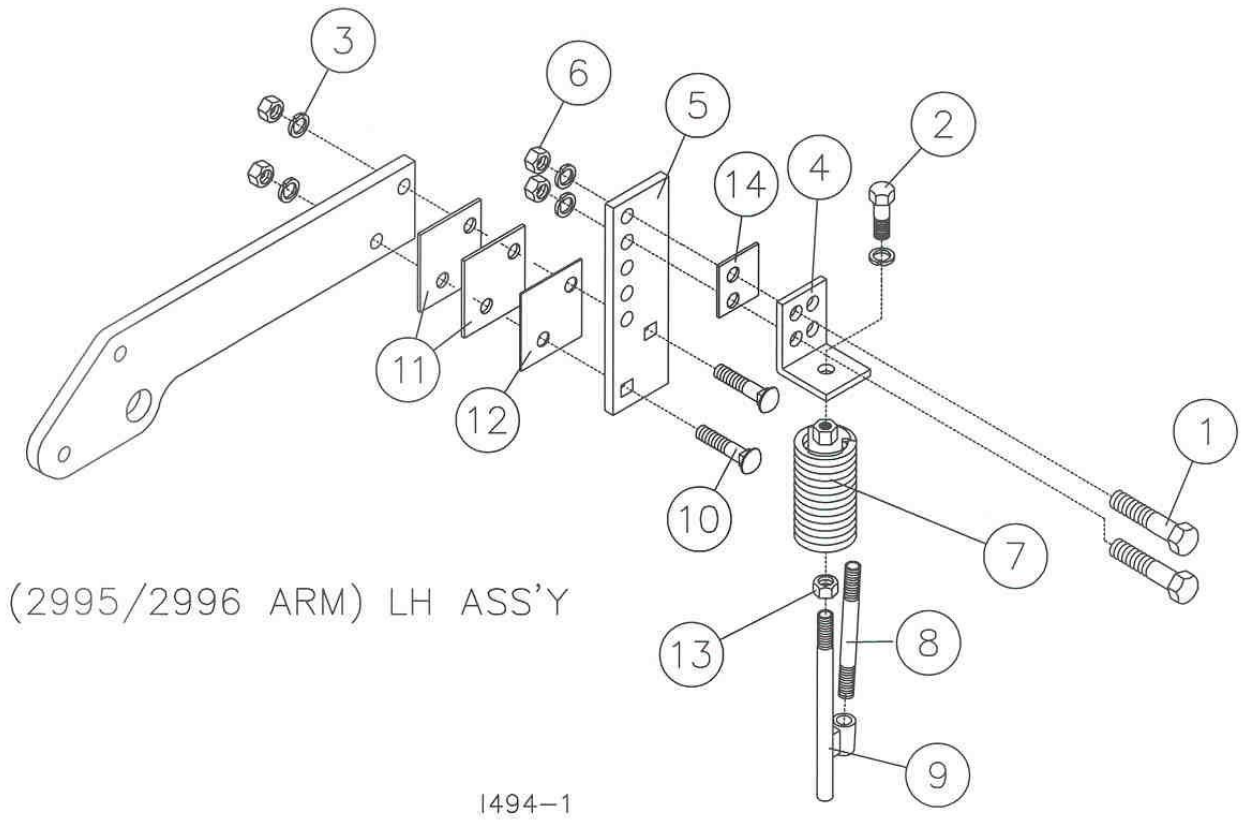

### 2995-109 SPRING MOUNT LIQ. FERT. INJECTOR KIT

Key	Qty.	Part No.	Description
1	2	2502-294	1/2-13 x 1-1/2 HHCS Gr. 5 ZP
2	1	2502-292	1/2-13 x 1 HHCS Gr. 5 ZP
3	5	2525-352	1/2 Med. Lock washer ZP
4	1	2995-301	Injector Mount Plate
5	1	2975-389	Adjustment Plate, Injector
6	4	2520-352	1/2-13 Hex Nut ZP
7	1	2995-131	Spring Injector Assembly
8	1	2515-311	3" Nipple, 1/4 NPT Stainless Steel
9	1	2995-212	Injector Rod W.A., 1/2-13
10	2	2505-344	1/2-13 x 1-3/4 Car. Bolt Gr. 5 ZP
11	2	2970-319	Knife Shim, 1/8", ZP
12	1	2970-320	Knife Shim, 16 GA., ZP
13	1	2520-356	1/2-13 Jam Hex Nut ZP
14	1	2995-320	Spacer, Injector

## PARTS IDENTIFICATION

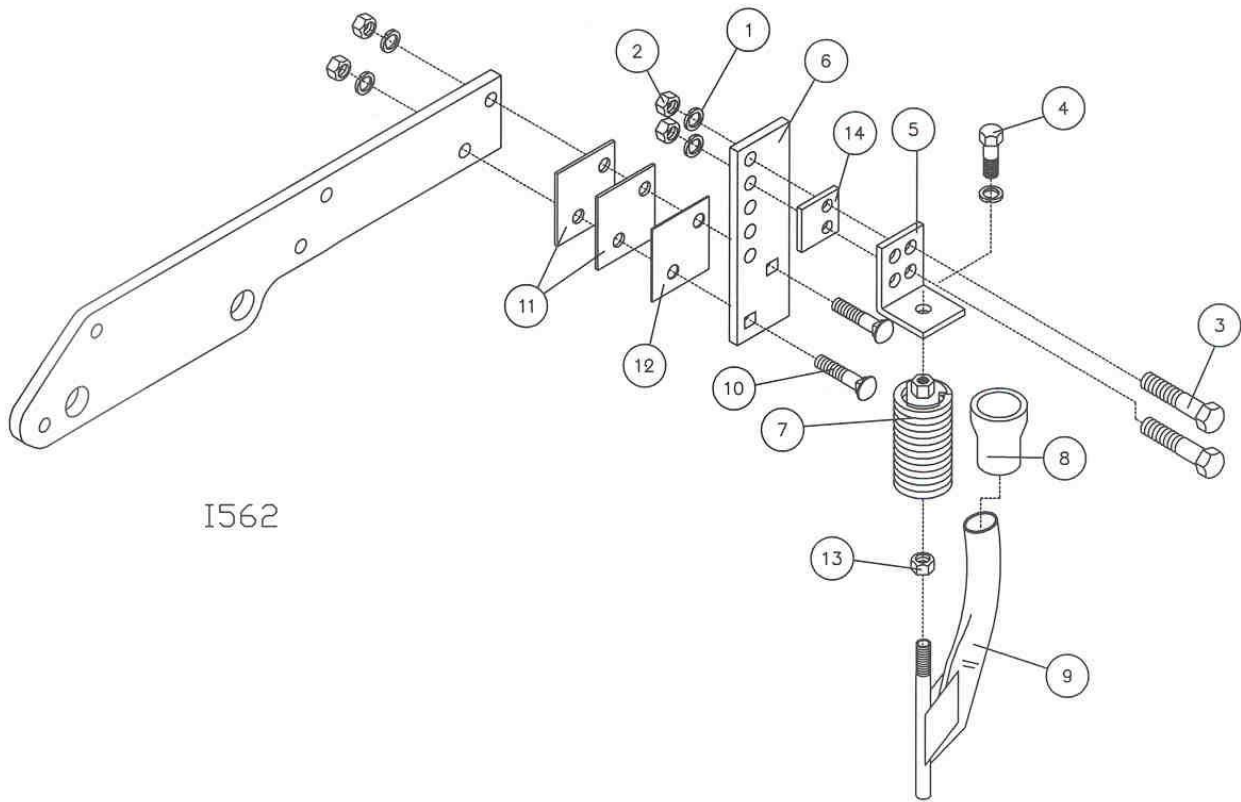

I562

### 2995-130 SPRING MOUNT DRY INJECTOR KIT

Key	Qty.	Part No.	Description
1	5	2525-352	1/2 Med. Lock washer ZP
2	4	2520-352	1/2-13 Hex Nut ZP
3	2	2502-294	1/2-13 x 1 1/2 HHCS Gr. 5 ZP
4	1	2502-292	1/2-13 x 1 HHCS Gr. 5 ZP
5	1	2995-301	Injector Mount Plate
6	1	2975-389	Adjustment Plate, Injector
7	1	2995-131	Injector Spring Assembly
8	1	2515-547	Dry Fertilizer Adapter, PVC
9	1	2995-213	Spring Tine Dry Injector W.A.
10	2	2505-344	1/2-13 x 1-3/4 Car. Bolt Gr. 5 ZP
11	2	2970-319	Knife Shim, 1/8", ZP
12	1	2970-320	Knife Shim, 16 Ga., ZP
13	1	2520-356	1/2-13 Jam Hex Nut
14	1	2995-320	Spacer, Injector

## PARTS IDENTIFICATION

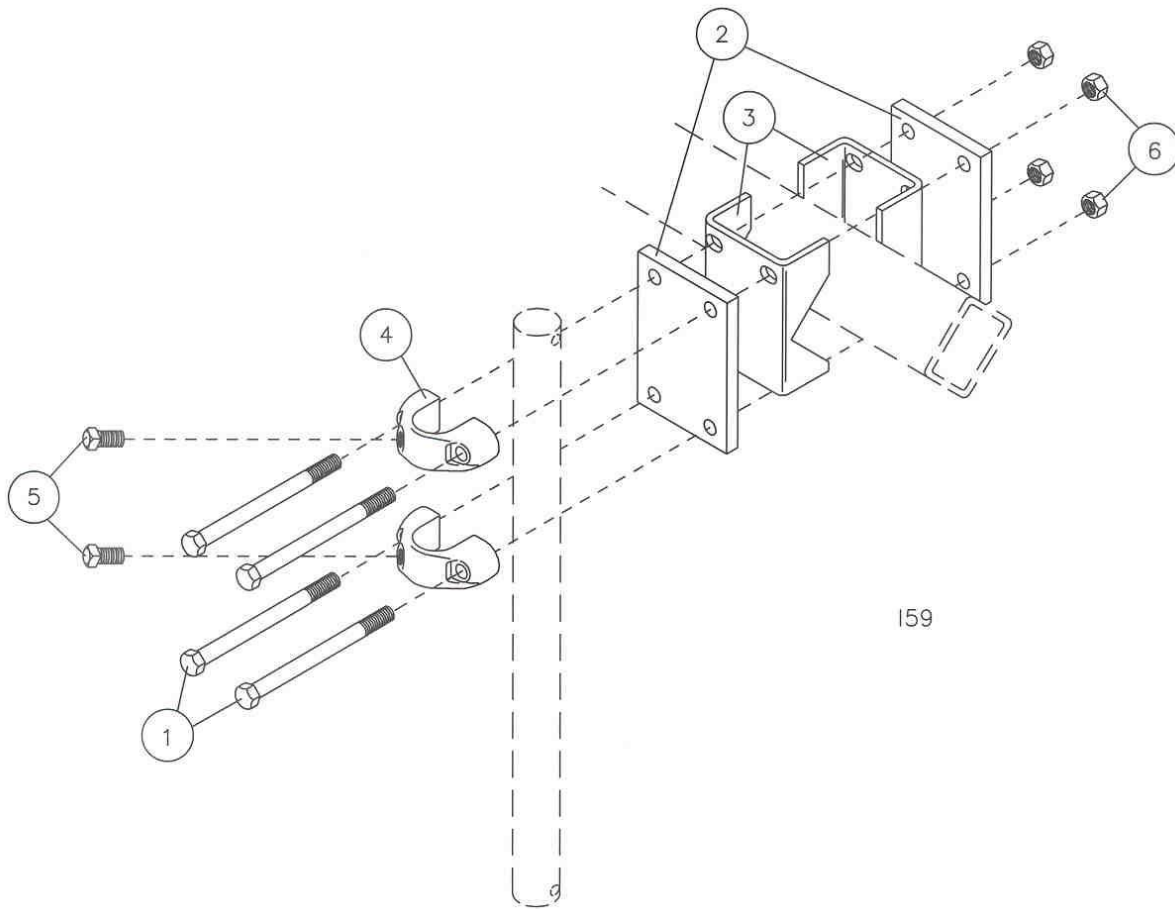

159

### 2990-159 Clamp Kit, 3" Diamond Bar

Key	Qty.	Part No.	Description
1	4	2502-369	1/2-13 x 8" HHCS Gr. 5 ZP
2	2	2990-314	Clamp Plate, 4" Sq. or 3" Diamond
3	2	2970-326	Adaptor, 3" Sq. Diamond Bar
4	2	2990-360	Clamp Casting, Drilled
5	2	2503-379	5/8-11 x 1" Sq. HCPSS Gr. 5 ZP
6	4	2520-357	1/2-13 Lock Hex Nut ZP

### 2990-160 Clamp Kit, 3-1/2" Diamond Bar

Key	Qty.	Part No.	Description
1	4	2502-374	1/2-13 x 9" HHCS Gr. 5 ZP
2	2	2990-316	Clamp Plate, 3-1/2" Diamond Bar
3	2	2970-327	Adaptor, 3-1/2" Sq. Diamond Bar
4	2	2990-360	Clamp Casting, Drilled
5	2	2503-379	5/8-11 x 1" Sq. HCPSS Gr. 5 ZP
6	4	2520-357	1/2-13 Lock Hex Nut ZP

### 2990-166 Clamp Kit, 2-1/4, 2-1/2 Diamond Bar

Key	Qty.	Part No.	Description
1	4	2502-371	1/2-13 x 7" HHCS Gr. 5 ZP
2	2	2990-348	Clamp Plate, 2-1/4, 2-1/2 Diamond Bar
3	2	2990-349	Adaptor, 2-1/4, 2-1/2 Diamond Bar
4	2	2990-360	Clamp Casting, Drilled
5	2	2503-379	5/8-11 x 1" Sq. HCPSS Gr. 5 ZP
6	4	2520-357	1/2-13 Lock Hex Nut ZP

# PARTS IDENTIFICATION

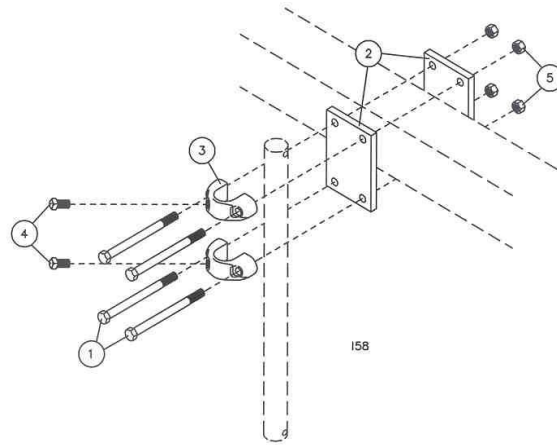

## 2990-154 Clamp Kit, 2-1/2" Sq. Bar

Key	Qty.	Part No.	Description
1	4	2502-368	1/2-13 x 5-1/2" HHCS GR. 5 ZP
2	2	2990-313	Clamp Plate, 2-1/2 Square Bar
3	2	2990-360	Clamp Casting, Drilled
4	2	2503-379	5/8-11 x 1 Sq. HCPSS Gr. 5 ZP
5	4	2520-357	1/2-13 Hex Lock Nut ZP

## 2990-155 Clamp Kit, 2 x 6 Bar

Key	Qty.	Part No.	Description
1	4	2502-362	1/2-13 X 5" HHCS GR. 5 ZP
2	2	2975-363	Clamp Plate, Universal
3	2	2990-360	Clamp Casting, Drilled
4	2	2503-379	5/8-11 x 1 Sq. HCPSS Gr. 5 ZP
5	4	2520-357	1/2-13 Hex Lock Nut ZP

## 2990-156 Clamp Kit, 4 x 4 Bar

Key	Qty.	Part No.	Description
1	4	2502-371	1/2-13 x 7" HHCS GR. 5 ZP
2	2	2990-314	Clamp Plate, 4" Sq. & 3" Diamond Bar
3	2	2990-360	Clamp Casting, Drilled
4	2	2503-379	5/8-11 x 1 Sq. HCPSS Gr. 5 ZP
5	4	2520-357	1/2-13 Hex Lock Nut ZP

## 2990-157 Clamp Kit, 5 x 7 Bar

Key	Qty.	Part No.	Description
1	4	2502-369	1/2-13 X 8" HHCS GR. 5 ZP
2	2	2990-315	Clamp Plate, 5 x 7 or 7 x 7 Bar
3	2	2990-360	Clamp Casting, Drilled
4	2	2503-379	5/8-11 x 1 Sq. HCPSS Gr. 5 ZP
5	4	2520-357	1/2-13 Hex Lock Nut ZP

## 2990-158 Clamp Kit, 7 x 7 Bar

Key	Qty.	Part No.	Description
1	4	2502-376	1/2-13 x 10" HHCS GR. 5 ZP
2	2	2990-315	Clamp Plate, 5 x 7 or 7 x 7 Bar
3	2	2990-360	Clamp Casting, Drilled
4	2	2503-379	5/8-11 x 1 Sq. HCPSS Gr. 5 ZP
5	4	2520-357	1/2-13 Hex Lock Nut ZP

## 2990-161 Clamp Kit, 3 x 7 Bar

Key	Qty.	Part No.	Description
1	4	2502-373	1/2-13 X 6" HHCS GR. 5 ZP
2	2	2990-315	Clamp Plate, 5 x 7 or 7 x 7 Bar
3	2	2990-360	Clamp Casting, Drilled
4	2	2503-379	5/8-11 x 1 Sq. HCPSS Gr. 5 ZP
5	4	2520-357	1/2-13 Hex Lock Nut ZP

## 2990-163 Clamp Kit, 3 x 3 Bar

Key	Qty.	Part No.	Description
1	4	2502-373	1/2-13 x 6" HHCS GR. 5 ZP
2	2	2990-339	Clamp Plate, 3" Square Bar
3	2	2990-360	Clamp Casting, Drilled
4	2	2503-379	5/8-11 x 1 Sq. HCPSS Gr. 5 ZP
5	4	2520-357	1/2-13 Hex Lock Nut ZP

## 2990-171 Clamp Kit, 3 x 4 Bar

Key	Qty.	Part No.	Description
1	4	2502-373	1/2-13 X 6" HHCS GR. 5 ZP
2	2	2990-314	Clamp Plate, 4" Sq. & 3" Dmd
3	2	2990-360	Clamp Casting, Drilled
4	2	2503-379	5/8-11 x 1 Sq. HCPSS Gr. 5 ZP
5	4	2520-357	1/2-13 Hex Lock Nut ZP

## 2975-151 Clamp Kit, 3 x 6 Bar

Key	Qty.	Part No.	Description
1	4	2502-373	1/2-13 x 6" HHCS GR. 5 ZP
2	2	2975-363	Clamp Plate, Universal
3	2	2990-360	Clamp Casting, Drilled
4	2	2503-379	5/8-11 x 1 Sq. HCPSS Gr. 5 ZP
5	4	2520-357	1/2-13 Hex Lock Nut ZP

## 2990-172 Clamp Kit, 4 x 6 Bar

Key	Qty.	Part No.	Description
1	4	2502-371	1/2-13 X 7" HHCS GR. 5 Zp
2	2	2975-363	Clamp Plate, Universal
3	2	2990-360	Clamp Casting, Drilled
4	2	2503-379	5/8-11 x 1 Sq. HCPSS Gr. 5 ZP
5	4	2520-357	1/2-13 Hex Lock Nut ZP

## 2990-173 Clamp Kit, 6 x 4 Bar

Key	Qty.	Part No.	Description
1	4	2502-374	1/2-13 x 9" HHCS GR. 5 ZP
2	2	2990-314	Clamp Plate, 4" Sq. & 3" Diamond Bar
3	2	2990-360	Clamp Casting, Drilled
4	2	2503-379	5/8-11 x 1 Sq. HCPSS Gr. 5 ZP
5	4	2520-357	1/2-13 Hex Lock Nut ZP

## 2990-174 Clamp Kit, 7 x 5 Bar

Key	Qty.	Part No.	Description
1	4	2502-376	1/2-13 X 10" HHCS GR. 5 ZP
2	2	2975-367	Clamp Plate, 5 Sq. Bar
3	2	2990-360	Clamp Casting, Drilled
4	2	2503-379	5/8-11 x 1 Sq. HCPSS Gr. 5 ZP
5	4	2520-357	1/2-13 Hex Lock Nut ZP

## 2990-175 Clamp Kit, 7 x 4 Bar

Key	Qty.	Part No.	Description
1	4	2502-376	1/2-13 x 10" HHCS GR. 5 ZP
2	2	2990-314	Clamp Plate, 4" Sq. 3" Diamond Bar
3	2	2990-360	Clamp Casting, Drilled
4	2	2503-379	5/8-11 x 1 Sq. HCPSS Gr. 5 ZP
4	2520-357	1/2-13 Hex Lock Nut ZP	

## 2990-182 Clamp Kit, 4 x 7 Bar

Key	Qty.	Part No.	Description
1	4	2502-371	1/2-13 X 7" HHCS GR. 5 ZP
2	2	2990-315	Clamp Plate, 5 x 7 or 7 x 7 Bar
3	2	2990-360	Clamp Casting, Drilled
4	2	2503-379	5/8-11 x 1 Sq. HCPSS Gr. 5 ZP 5
5	4	2520-357	1/2-13 Hex Lock Nut ZP

## PARTS IDENTIFICATION

### 2910-147-RH RIGHT HAND HIGH CLEARANCE INJECTOR KIT

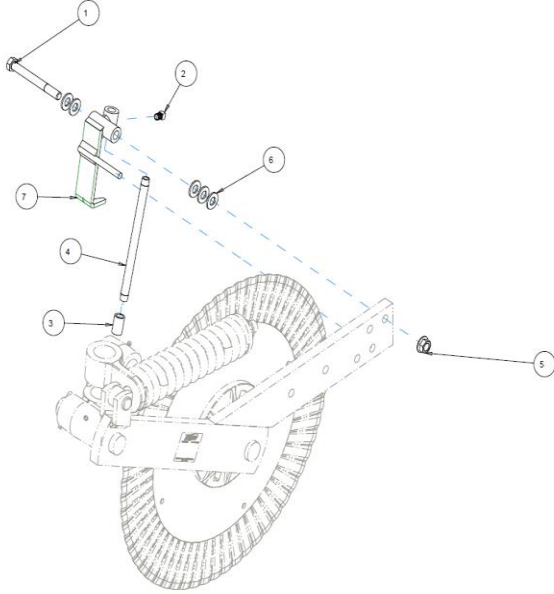

ITEM	PART NO.	DESCRIPTION	QTY
1	2502-297	1/2-13 X 4.5 HHCS 304 STAINLESS	1
2	2503-256	3/8-16X1/2SQHCPSS GR5 STAINLSS	1
3	2515-312	1/4 NPT X 1 1/16 COUPLER SS	1
4	2515-318	8"NIPPLE 1/4 NPT STAINLESS	1
5	2520-366	1/2"-13 SERRATED FLANGE LOCK NUT, 316 STAINLESS	1
6	2526-357	1/2" SAE FLATWASHER SS	5
7	2910-218	INJECTOR HOLDER W.A., RH	1

### 2910-147-LH LEFT HAND HIGH CLEARANCE INJECTOR KIT

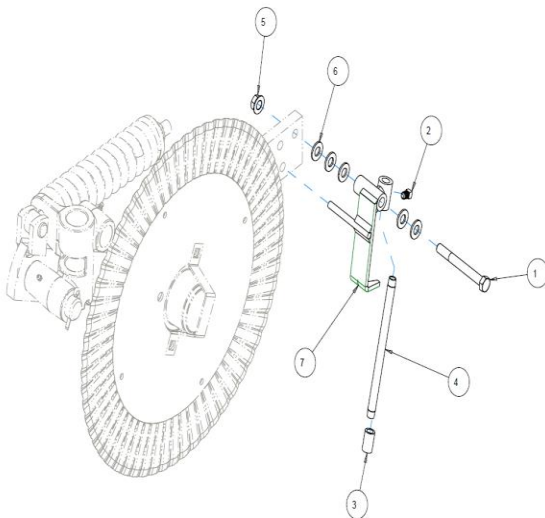

ITEM	PART NO.	DESCRIPTION	QTY
1	2502-297	1/2-13 X 4.5 HHCS 304 STAINLESS	1
2	2503-256	3/8-16X1/2SQHCPSS GR5 STAINLSS	1
3	2515-312	1/4 NPT X 1 1/16 COUPLER SS	1
4	2515-318	8"NIPPLE 1/4 NPT STAINLESS	1
5	2520-366	1/2"-13 SERRATED FLANGE LOCK NUT, 316 STAINLESS	1
6	2526-357	1/2" SAE FLATWASHER SS	5
7	2910-219	INJECTION HOLDER W.A., LH	1

## TROUBLESHOOTING

<u>Problem</u>	<u>Cause</u>	<u>Solution</u>
Setting coulter	Planter not set correctly	Ensure that in operation the planter frame is at correct height (20"-22") and level the toolbar. See opposite page.
Trash plugging	Excessive knife-blade clearance	Check and adjust knife-blade clearance. See page 9.
	Knife not correctly aligned behind blade	Use shims to align knife behind blade
Blade not penetrating	Insufficient coulter spring pressure	Tighten coulter spring locknut down 1" further
	Coulter incorrectly installed	Adjust height of coulter by sliding shank down
Spring not deflecting	Excessive spring pressure	Back off coulter spring locknut to 1/8" of thread exposed
Fertilizer too deep	Spring not deflecting	Back off coulter spring locknut to 1/8" of thread exposed
	Coulter incorrectly installed	Adjust height of coulter by sliding shank up
	Lack of depth control	Install gauge wheel kit, part no. 2975-120
	Planter frame too low	Raise planter frame to correct height
Fertilizer too shallow	Blade not penetrating	Tighten coulter spring locknut down 1" further
	Coulter incorrectly installed	Adjust height of coulter by sliding shank down
Fertilizer will not flow	Plugged fertilizer tubes	Check for plugged fertilizer tube openings on knife
		Check for plugged fertilizer delivery tubes on planter
Blade not rotating properly	Loose soil	Coulter works best in firmer soil conditions



A Tradition of Solutions since 1930

Yetter Farm Equipment Co

PO BOX 358 109 S. McDonough

Colchester, IL 62326-0358

Phone: 309-776-4111

Toll Free: 800-447-5777

Email: [info@yetterco.com](mailto:info@yetterco.com)

For updated models and manuals visit the Yetter website:

[www.yetterco.com](http://www.yetterco.com)

© Yetter Farm Equipment Co. All Rights Reserved

2565-490\_REV\_G  08/2024