



2987 NH3 MAGNUM

2565-758_REV_R • 08/2024



YETTER MANUFACTURING CO.

FOUNDED 1930

Colchester, IL 62326-0358

Toll free: 800/447-5777

309/776-3222 (Fax)

Website: www.yetterco.com

E-mail: info@yetterco.com

YETTER

FOREWORD

You've just joined an exclusive but rapidly growing club.

For our part, we want to welcome you to the group and thank you for buying a Yetter product.

We hope your new Yetter products will help you achieve both goals-increase your productivity and increase your efficiency so that you may generate more profit.

This operator's manual has been designed into four major sections: Foreword, Safety Precautions, Installation Instructions and Parts Breakdown.

This **SAFETY ALERT SYMBOL** indicates important safety messages in the manual. When you see this symbol, be alert to the possibility of **PERSONAL INJURY** and carefully read the message that follows.



DANGER: Indicates an imminently hazardous situation which, if not avoided "will" result in death or serious injury. This signal word is to be limited to the most extreme situations



WARNING: Indicates a potentially hazardous situation which, if not avoided, "could" result in death or serious injury.



CAUTION: Indicates a potentially hazardous situation, which if not avoided, "may" result in minor or moderate injury. It may also be used to alert against unsafe practices.



NOTICE: Indicates information considered important, but not hazard related (e.g., messages relating to property damage).

It is the responsibility of the user to read the operator's manual and comply with the safe and correct operating procedure and to lubricate and maintain the product according to the maintenance schedule in the operator's manual.

The user is responsible for inspecting his machine and for having parts repaired or replaced when continued use of the product would cause damage or excessive wear to the other parts.

It is the user's responsibility to deliver his machine to the Yetter dealer who sold him the product for service or replacement of defective parts, which are covered by the warranty policy.

If you are unable to understand or follow the instructions provided in this publication, consult your local Yetter dealer or contact:

YETTER MANUFACTURING CO.

309/776-4111

800/447-5777

309/776-3222 (FAX)

Website: www.yetterco.com

E-mail: info@yetterco.com

WARRANTY

Yetter Manufacturing warrants all products manufactured and sold by it against defects in material. This warranty being expressly limited to replacement at the factory of such parts or products as shall appear to be defective after inspection. This warranty does not obligate the Company to bear cost of labor in replacement of parts. It is the policy of the Company to make improvements without incurring obligations to add them to any unit already sold. No warranty is made or authorized to be made, other than herein set forth. This warranty is in effect for one year after purchase.

DEALER: _____

Yetter Manufacturing warrants its own products only and cannot be responsible for damages to equipment on which mounted.



SAFETY PRECAUTIONS



A brief description of signal words that may be used in this manual:

DANGER: Indicates an imminently hazardous situation which, if not avoided “will” result in death or serious injury. This signal word is to be limited to the most extreme situations.

WARNING: Indicates a potentially hazardous situation which, if not avoided, “could” result in death or serious injury.

CAUTION: Indicates a potentially hazardous situation, which if not avoided, “may” result in minor or moderate injury. It may also be used to alert against unsafe practices.

NOTICE: Indicates information considered important, but not hazard related (e.g., messages relating to property damage).

Consult your implement and tractor operator’s manual for correct and safe operating practices. Be aware of towed implement width and allow safe clearance.

Safety decals are placed on the implement to alert the operator and others to the risk of personal injury or unsafe operation during normal operations and servicing.

1. The safety decals must be kept clean and in good condition to ensure that they are legible.
2. Safety decals must be replaced if they are missing or illegible.
3. When components are replaced during repair or servicing, check that the new components include the necessary safety signs.
4. Replacement safety decals may be obtained from your local dealer.



WARNING

Read these instructions carefully to acquaint yourself with the Equipment. Working with unfamiliar equipment can lead to accidents.

Never park the equipment on a steep incline or leave the equipment running unattended.

Never clean, lubricate or adjust a machine that is in motion.

Always check that straps are secure.

Make sure latches are in pinned position when moving equipment.

Do not allow children to operate this equipment.

Do not allow riders on the equipment, trailer and/or pick-up.

Use speed and caution dictated by the terrain being traversed. Do not operate on any slope steep enough to cause tipping or loss of control.

Read and understand the operator’s manual and require all other persons who will operate the equipment to do the same.

If operating on public roadways, where legal, be certain all lighting is operating properly and observe all traffic laws.

Beware of increased stopping distances and control effort when operating with implements attached.

Be familiar with all controls and be prepared to stop equipment quickly in an emergency.

FAILURE TO HEED MAY RESULT IN PERSONAL INJURY OR DEATH.



BOLT TORQUE



NOTICE READ THESE INSTRUCTIONS FIRST:

1. **Improperly tightened bolts will result in damage, breakage, expense, and down time.**
2. **Always replace bolts with the specified grade and type.**
3. **Torque properly before first use of the machine and every 2-4 hours of use until you are sure bolts are staying tight.**
4. **The chart below is a guide for proper torque. Use it unless a specified torque is called out elsewhere in the manual.**
5. **Torque is the force you apply to the wrench handle or the cheater bar, times the length of the handle or bar.**
6. **Use a torque wrench whenever possible.**

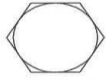
The following table shows torque in ft. lbs.

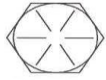
BOLT DIA. AND THREADS PER INCH		 OR 	
	GRADE 2	GRADE 5 A-325	GRADE 8
3/8-16	25	35	50
7/16-14	35	55	80
1/2-13	55	85	125
9/16-12	75	125	175
5/8-11	105	170	235
3/4-10	185	305	425
7/8-9	170	445	690
1-8	260	670	1030
1 1/8-7	365	900	1460
1 1/4-7	515	1275	2060
1 3/8-6	675	1675	2700
1 1/2-6	900	2150	3500
1 3/4-5	1410	3500	5600



WARNING: Never work around the toolbar / implement while in a raised position without using safety lockups.

Model No.	Description	Est. Wt.
2987-150-L	LH NH3 Magnum™ w/ Wheel and Knife	260 lbs.
2987-150-R	RH NH3 Magnum™ w/ Wheel and Knife	260 lbs.

Model No.	Description	Est. Wt.
2987-040-L	LH NH3 (3/8")Tube Kit	.395 lbs.
2987-040-R	RH NH3 (3/8") Tube Kit	.395 lbs.
2987-041-L	LH NH3 w/ Liquid (3/8" Dual) Tube Kit	.697 lbs.
2987-041-R	RH NH3 w/ Liquid (3/8" Dual) Tube Kit	.697 lbs.
2987-042-L	LH NH3 w/ Vapor (3/8" & 3/4") Tube Kit	.954 lbs.
2987-042-R	RH NH3 w/ Vapor (3/8" & 3/4") Tube Kit	.954 lbs.
2987-043-L	LH NH3 w/ Liquid & Vapor (3/8" Dual & 3/4" Single) Tube Kit	1.044 lbs.
2987-043-R	RH NH3 w/ Liquid & Vapor (3/8" Dual & 3/4" Single) Tube Kit	1.044 lbs.
2987-044-L	LH Vapor Only (3/4")Tube Kit	.455 lbs.
2987-044-R	RH Vapor Only (3/4") Tube Kit	.455 lbs.
2987-046	Liquid (1/2" Single) Tube Kit	.850 lbs.
2987-047	Liquid (1/2" Dual) Tube Kit	1.159 lbs.
2987-050	Dry (1-1/2")Tube Kit	1.404 lbs.
2987-051	Dry w/ NH3 (1-1/2" & 3/8") Tube Kit	1.987 lbs.
2987-052	Dry w/ NH3 & Vapor (1-1/2" & 3/8" & 3/4") Tube Kit	2.55 lbs.

Model No.	Description	Est Wt.
2987-135	6" x 6" & 6" x 4" clamp kit	10 lbs.
2987-136	4" x 6" & 4" x 4" clamp kit	10 lbs.
2987-140	7" x 7" clamp kit	10 lbs.
2987-141	5" x 7" clamp kit	10 lbs.

Closing wheels:

2987-027-L-ST	LH Sealer Kit with shark tooth® wheels	53 lbs.
2987-027-R-ST	RH Sealer Kit with shark tooth® wheels	53 lbs.

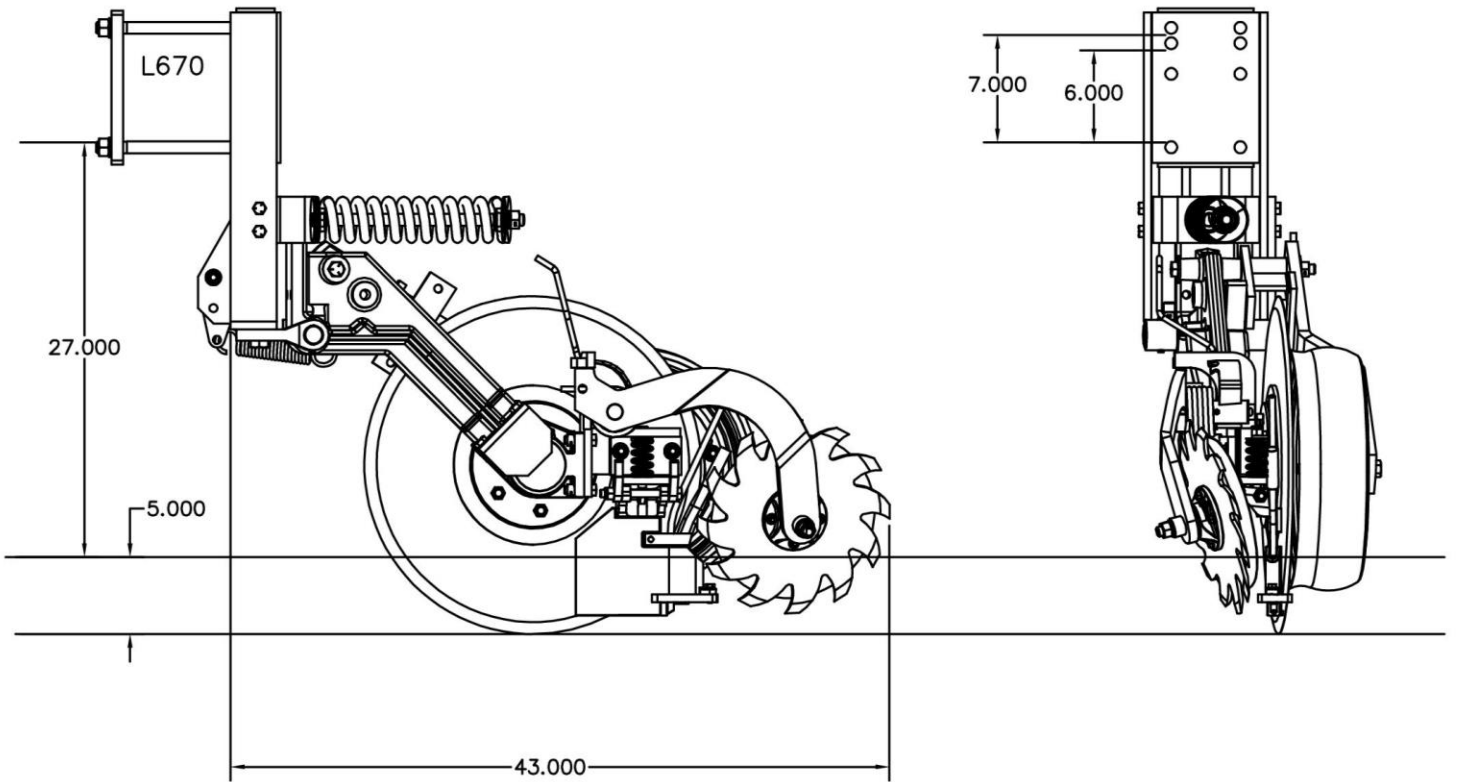
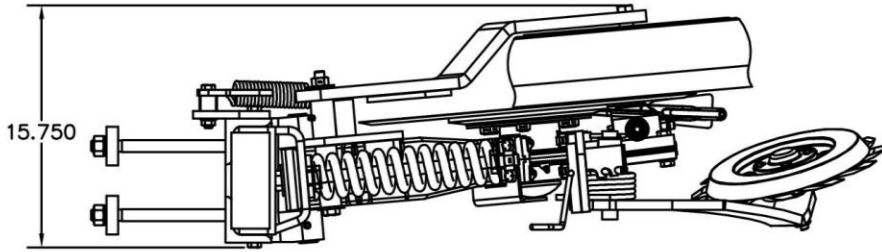

ASSEMBLY INSTRUCTIONS

The 2987 NH3 Magnum couler is designed to mount to rectangular toolbars in three sizes: 5" x 7", 6" x 6" or 7" x 7".



WARNING: Never work under the toolbar while in a raised position without using safety lockups.



WARNING: Use extreme caution, the blade is sharp and may cause bodily injury.

The couler can be mounted to the toolbar using different techniques. One way is to mount the main arm assembly to the toolbar and then attach the components one at a time. Another way is to completely assemble the avenger couler before attaching to the toolbar frame. To aid the assembly of the opener, it is recommended that a stand be constructed to temporarily attach the opener and hold it in an upright position.



CAUTION: The 2987 NH3 Magnum couler and its components are very heavy. Extra attention to lifting techniques while handling and or maneuvering the couler during assembly is very important. **Failure to do so may lead to personal injury or death.**

STEP 1.

Mark the toolbar frame as to the location that each couler is to be mounted.

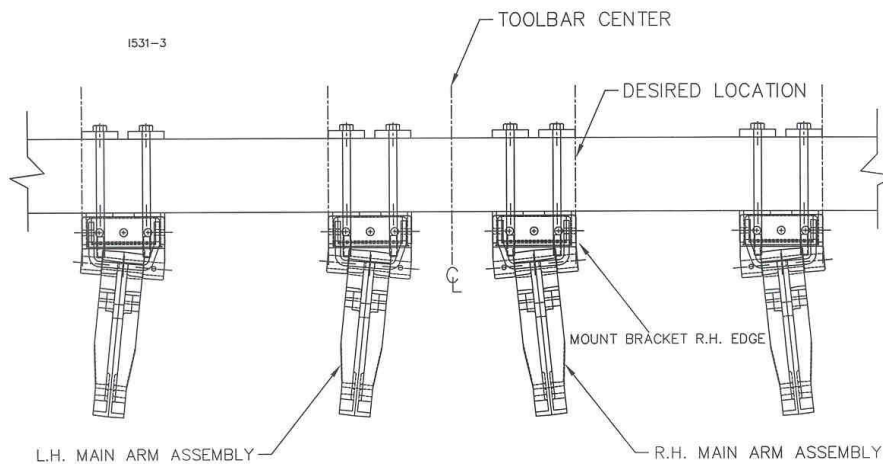

NOTE: The couler blade is in line with the edge of the mount bracket, for a reference use the edge of the mounting bracket (right hand edge for a right hand and left hand edge for a left hand) to align with the mark on the toolbar so that the coulers are mounted at the desired spacing.

STEP 2.

Attach the main arm assembly to the toolbar using 2) 2986-306 mounting straps, 4) hex head bolts, $\frac{3}{4}$ " lock washers and $\frac{3}{4}$ " hex nuts.

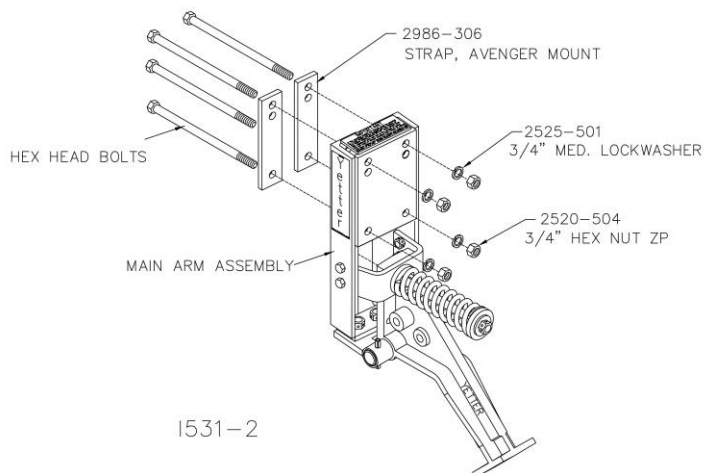

TOOLBAR FRAME HEIGHT ADJUSTMENT

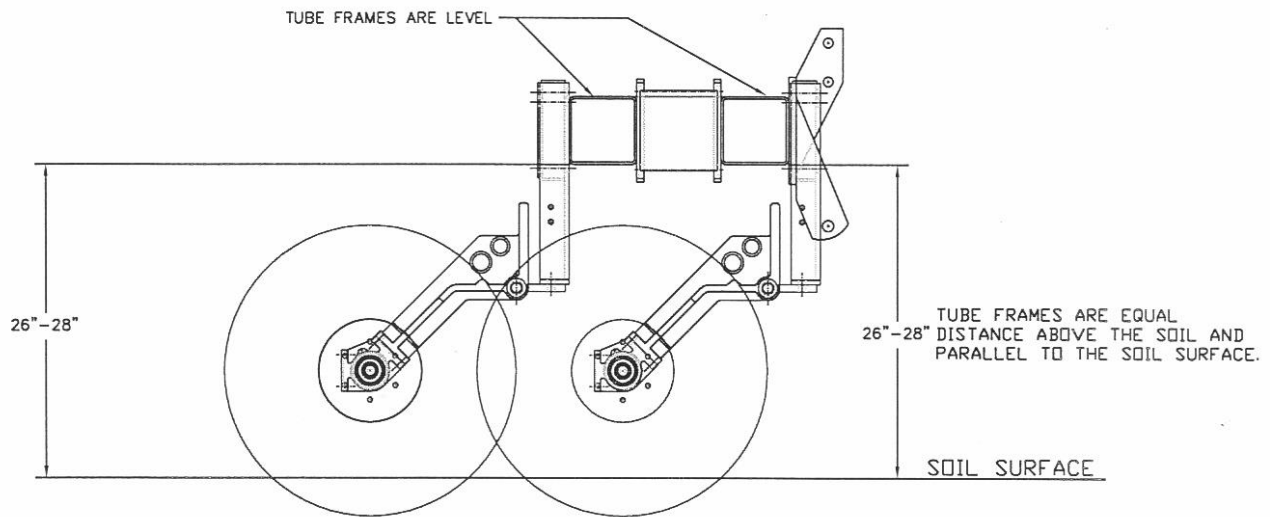

FIGURE A. (CORRECT)

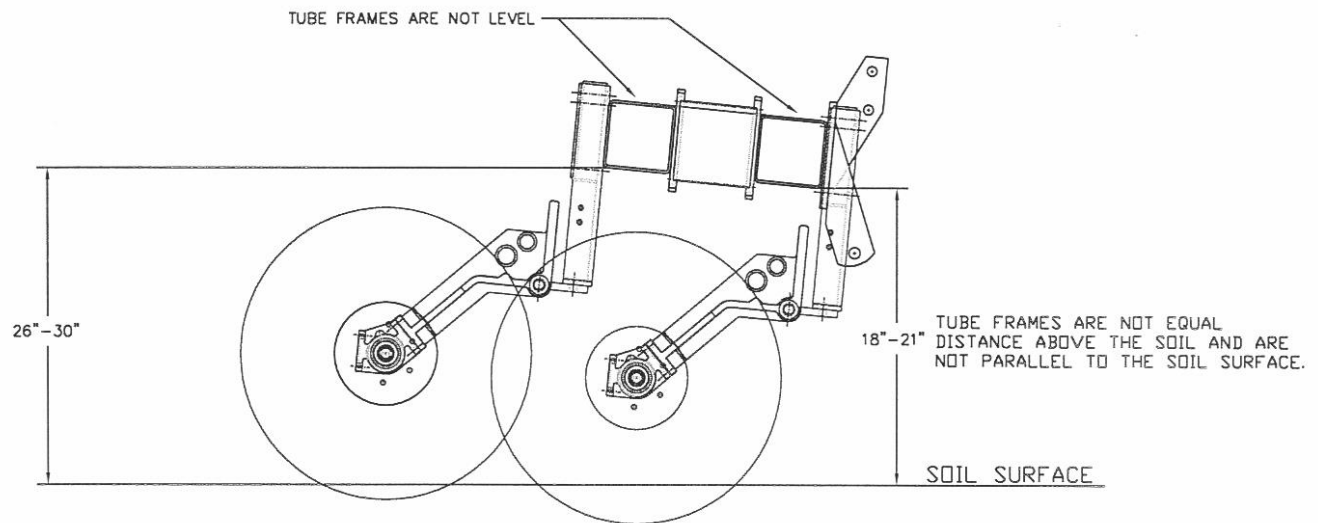

FIGURE B. (INCORRECT)

L374-3

Figure A. The toolbar frames are equally 26"-28" off the ground. To ensure that frame heights are equal, it is important that measurements are taken. The tube frames should be parallel with the soil surface.

Figure B. The hitch is set too low while the toolbar frames are not equal distance from the soil surface.

The illustrations are intended to show that the settings are critical. **Tool frame levelness and height adjustment are very important settings for correct performance of the coulters.**

OPERATION INSTRUCTIONS

RIGHT HAND ASSEMBLY DIRECTION OF TRAVEL

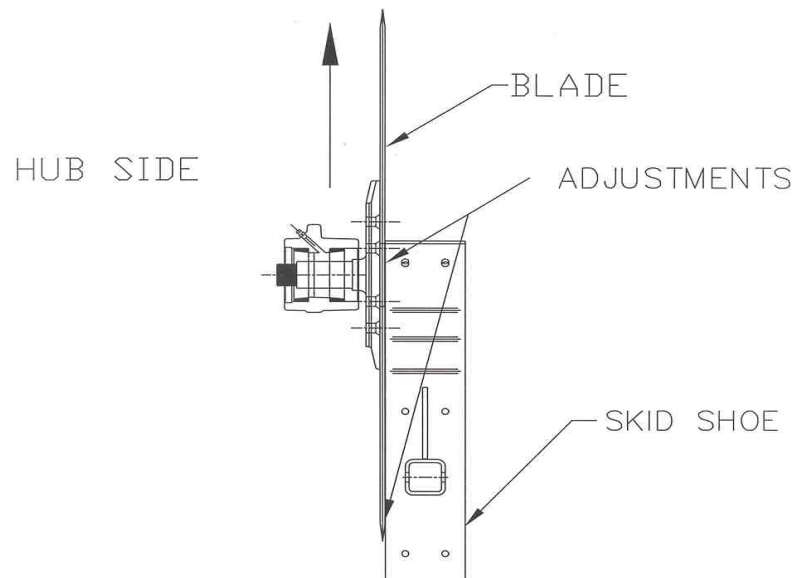

1. Adjust the shoe the same front and back.
2. Start with no gap between the blade and shoe.
3. Set the shoe just touching the blade.

OPERATION MAINTENANCE

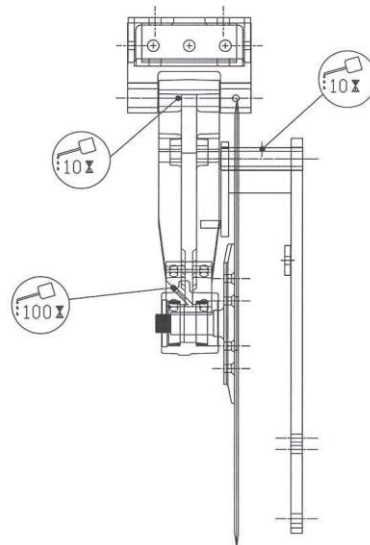

LUBRICATION: Each coulter is equipped with (3) grease zerks. To ensure longevity and reliability of the coulter, the recommended lubrication schedule should be followed using general purpose grease at hourly intervals indicated on symbol.

MAINTENANCE

Lubrication



CAUTION: To help prevent serious injury or death to you or others caused by unexpected movement, service machine on a level surface. Lower machine to ground or sufficiently lock or block raised machine before servicing. If machine is connected to tractor, engage parking brake and place transmission in "PARK", shut off engine and remove key. If machine is detached from tractor, block wheels and use shop stands to prevent movement.



CAUTION: Do not clean, lubricate, or adjust machine while in motion.

Use grease based on NLGI consistency numbers and the expected air temperature range during the service interval.

Use a **multi-purpose polyurea, water resistant, moderate speed, and NLGI grade #2** grease.

Other greases may be used if they meet the following **NLGI Performance Classification: GC-LB**

IMPORTANT: Some types of grease thickener are not compatible with others. Consult your grease supplier before mixing different types of grease.

Alternative Lubricants

Conditions in certain geographical areas may require special lubricants and lubrication practices which do not appear in the operator's manual. If there are any questions, consult Yetter Manufacturing Co. to obtain latest information and recommendation.

Storing Lubricants

Your machine can operate at top efficiency only if clean lubricants are used.

Use clean containers to handle all lubricants.

Store them in an area protected from dust, moisture and other contaminants.

MAINTENANCE

Storing the Equipment

Store the machine in an area away from human activity

Store machine in RAISED position.

Install service locks on all wheel cylinders.

At the end of the season, the machine should be thoroughly inspected and prepared for storage. Repair or replace any worn or damaged components to prevent down time at the start of the next season. Store machine under cover with all parts in operating condition.

- Clean machine thoroughly to remove all dirt, debris and crop residue, which would hold moisture and cause rusting.
- Inspect machine for worn or broken parts. See your Yetter Farm Equipment dealer during the off-season so that parts or service can be acquired when machine is not needed in the field.
- Lubricate bearings as outlined in the Lubrication section
- Paint all parts which are chipped or worn and require repainting.
- Store machine in a clean, dry place with the planting unit out of the sun.
- If the machine cannot be stored inside, cover with a waterproof tarpaulin and tie securely in place.
- Do not allow children to play on or around the machine

OPERATION MAINTENANCE

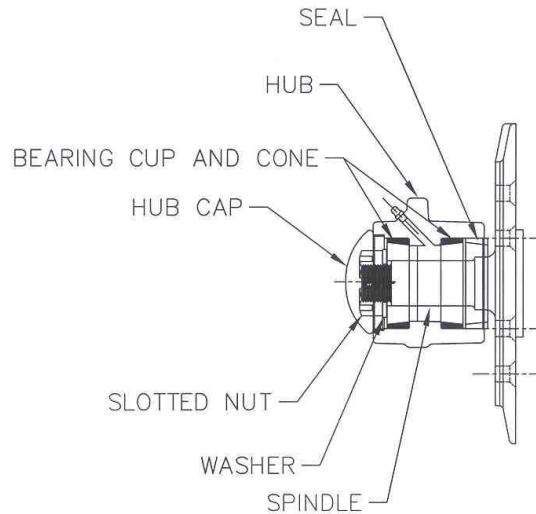

BEARING ADJUSTMENT:

1. Raise the toolbar until the blade is clear of the ground. Place a safety stand under the toolbar. Remove the blade. Remove the hub cap, cotter pin, slotted nut, washer and spacer from the spindle shaft assembly.
2. Pull the coulter spindle shaft assembly from the hub. Remove bearing cones and seal.
3. Wash the old grease from the hub, bearing cups, coulter spindle shaft, seal and bearing cones. Inspect the condition of bearing cups, cones and seal. Replace if necessary.
4. Apply #2 multi-purpose lithium grease on each bearing. Make sure the space around each roller is filled. Lubricate the bearing cups.
5. Position the bearing in the cup and install the seal. Lubricate the seal lips and proceed with re-assembly of the removed parts including the blade. Blade bolt torque is 90 to 96 ft/lbs.
6. Tighten the slotted nut to 10 to 15 ft/lbs. or until a definite drag is felt when the blade is turned by hand. Back off the nut one slot position to line up the cotter pin hole with a slot. Secure the nut with a new cotter pin.

KNIFE WEAR:

The lower portion of the scraper and tube are subject to wear during operation. The rate of wear will depend on a variety of factors and in abrasive hard soil conditions the wear will be more rapid.

NOTE: In certain areas, replacement knives should be kept in stock, replacing worn knives as needed.

ADJUST KNIFE TO BLADE CONTACT on each opener so the blade will turn by hand with slight resistance, but will not coast or freewheel. In loose soil the knife adjustment is critical. If adjustment is not maintained, soil or residue may wedge between knife and blade, resulting in the blade not turning. Because of blade run out, rotate the blade one full revolution after adjustment. Re-adjust knife as needed. Never strike the knife with a heavy object or damage may occur. To adjust use shims or to adjust knife mounting out make adjustment to the nut on top of spring for tension on blades.

PARTS IDENTIFICATION

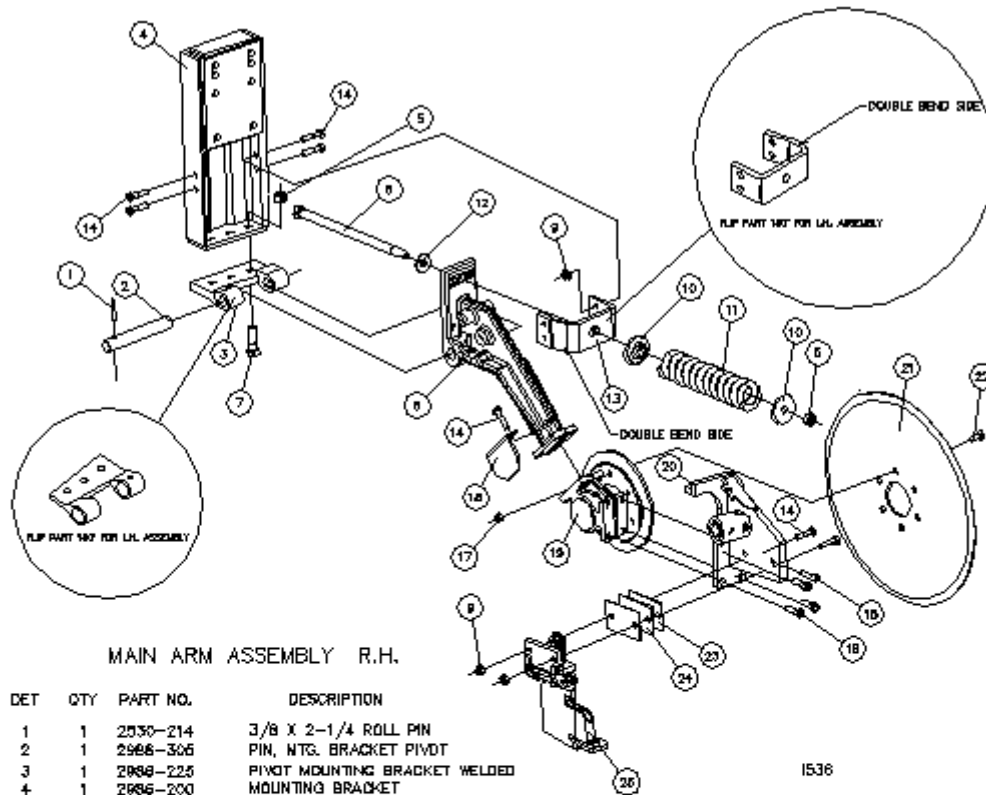

MAIN ARM ASSEMBLY R.H.

DET	QTY	PART NO.	DESCRIPTION
1	1	2530-214	3/8 X 2-1/4 ROLL PIN
2	1	2966-306	PIN, MTC. BRACKET PIVOT
3	1	2968-225	PIVOT MOUNTING BRACKET WELDED
4	1	2966-200	MOUNTING BRACKET
5	4	2520-515	3/4-10 HEX LOCK NUT
6	1	2502-503	3/4-10 X 15-1/2 HHCS GR. 5
7	3	2502-503	3/4-10 X 2 HHCS GR. 5
8	1	2968-401	MOUNTING ARM
9	1	2533-110	1/4-28 ZERK STRAIGHT SELF-TAP
9	6	2520-361	1/2-13 FLANGE WHZLCK NUT
10	2	2966-406	BUSHING, SPRING
11	1	2968-342	COMPRESSION SPRING, AVENGER
12	1	2526-501	3/4 STANDARD FLATWASHER
13	1	2966-315	SPRING MTC. BRACKET
14	10	2502-351	1/2-13 X 2 HHCS GR. 5
15	1	2510-176	1/2-13 X 1.75" SHCS
16	3	2502-317	1/2-13 X 1-3/4 HHCS GR5
17	6	2520-357	1/2-13 LOCK HEX NUT
18	1	2968-316	BRACKET, HUB CAP RETAINER
19	1	2968-111	HUB & SPINDLE ASSEMBLY
20	1	2967-270	RH KNIFE MOUNT (SHOWN)
20	1	2967-267	LH KNIFE MOUNT
21	1	2971-279	.250 X 22" COLLTER BLADE
22	6	2506-306	1/2-13 X 1-1/2#3PLWELT GR.5
23	1	2965-315	SIDE KNIFE SHIM,16 GA.
24	2	2965-316	SIDE KNIFE SHIM, 1/8"
25	1	2967-045-R	MAGNUM SIDE KNIFE ASSY, RH (SHOWN)
25	1	2967-045-L	MAGNUM SIDE KNIFE ASSY, LH

1536

RIGHT HAND ASSEMBLY SHOWN

UPDATED 06/25/2022

PARTS IDENTIFICATION

2986-111 HUB & SPINDLE ASSY.

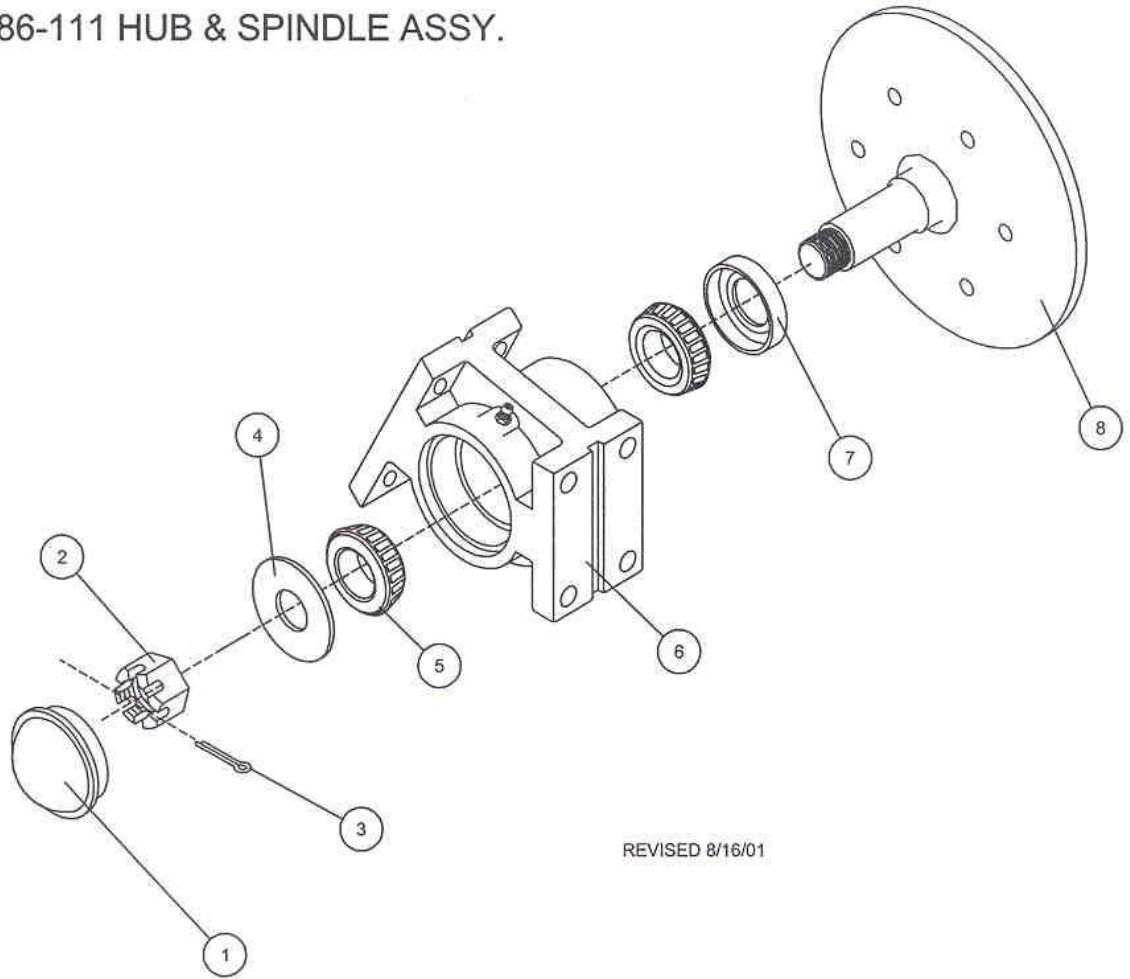

REVISED 8/16/01

I532

KEY	QTY.	PART NUMBER	DESCRIPTION
1	1	2550-065	HUB CAP, WILTON #909912-1
2	1	2986-329	MACH. CASTLE NUT 1 1/4-12
3	1	2531-124	3/16 X 2 COTTER PIN
4	1	2526-562	1 17/64 ID X 2 1/4 OD X 10 GA. MB BLK
5	2	2550-057	BEARING, KOYO #2788R
6	1	2986-403	MOUNTING HUB
	1	2533-110	1/4-28 ZERK STRAIGHT SELF-TAP
	2	2550-056	CUP, KOYO #2729
7	1	2550-058	SEAL, CR #17699
8	1	2986-402	25" COULTER SPINDLE

NOTE: Detail #2 is to be torqued to between 10 and 15 ft/lbs.

PARTS IDENTIFICATION

2987-040-R

NH3 FERT KIT, RH

DET	QTY	PART NO.	DESCRIPTION
1	1	2520-206	5/16-18 FLANGE LOCK NUT
2	1	2987-248-R	RH FERT TUBE W.A., L / N
3	1	2505-205	5/16-18 X 3/4 CARBOLT G5 ZP
4	1	2987-412	FULL PLUG

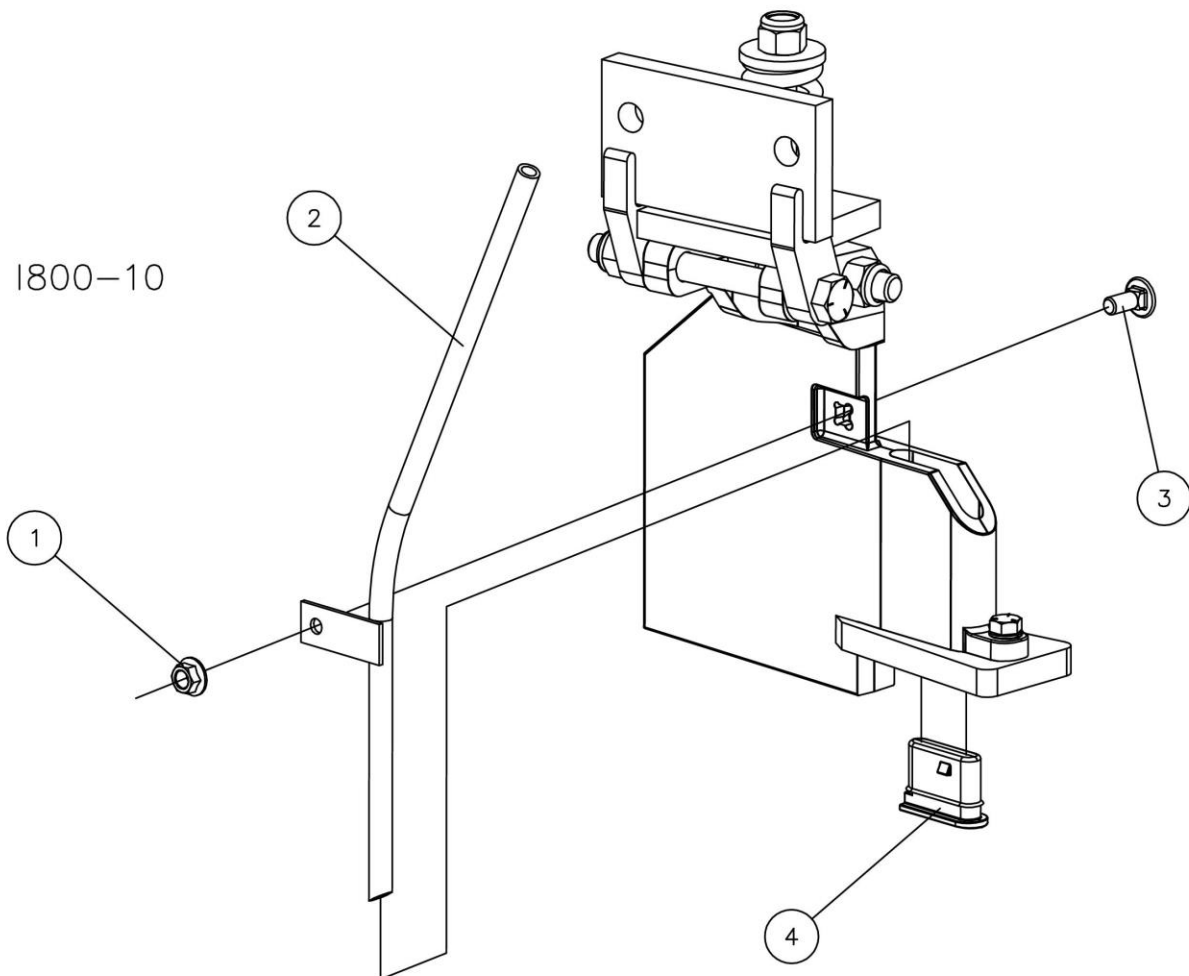

PARTS IDENTIFICATION

2987-041-R

NH3 W/ LIQ FERT KIT, RH

DET	QTY	PART NO.	DESCRIPTION
1	1	2520-206	5/16-18 FLANGE LOCK NUT
2	1	2987-247-R	RH FERT TUBE W.A., NH3 W/ LIQ.
3	1	2505-205	5/16-18 X 3/4 CARBOLT G5 ZP
4	1	2987-414	3/4 PLUG

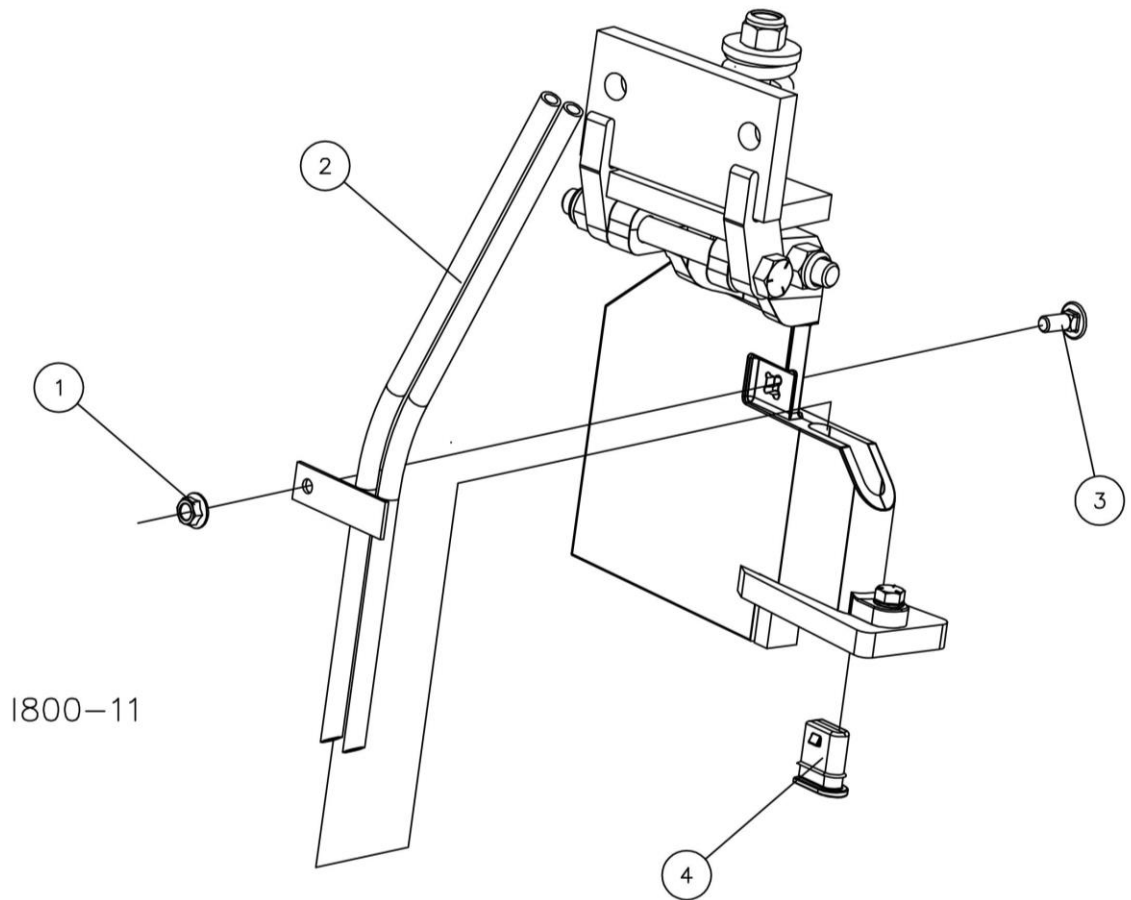

PARTS IDENTIFICATION

2987-042-R

NH3 W/ VAPOR FERT KIT, RH

DET	QTY	PART NO.	DESCRIPTION
1	1	2520-206	5/16-18 FLANGE LOCK NUT
2	1	2987-246-R	RH FERT TUBE W.A., NH3 W/ V
3	1	2505-205	5/16-18 X 3/4 CARBOLT G5 ZP
4	1	2987-413	1/2 PLUG

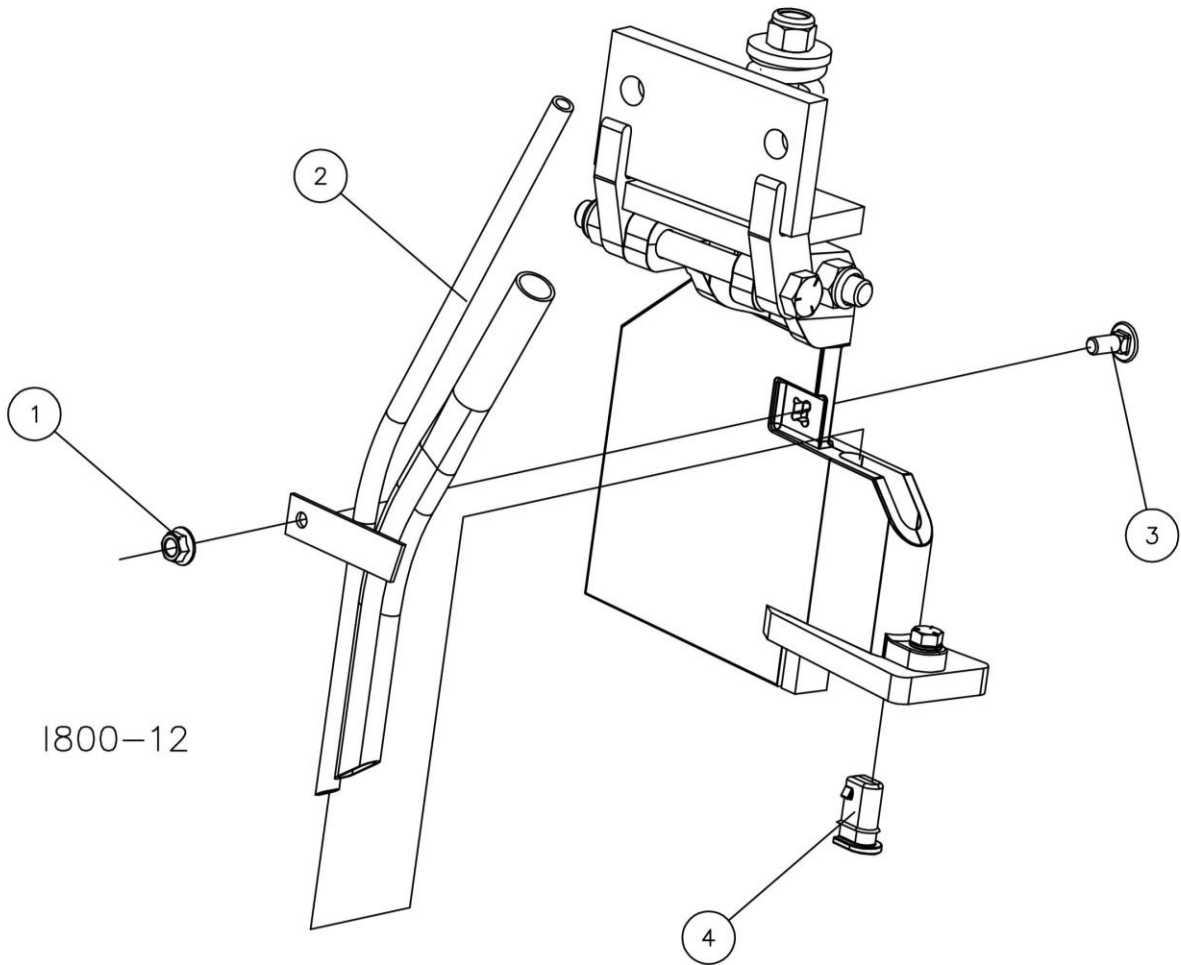

PARTS IDENTIFICATION

2987-043-R

NH3 W/ L & V FERT KIT, RH

DET	QTY	PART NO.	DESCRIPTION
1	1	2520-206	5/16-18 FLANGE LOCK NUT
2	1	2987-249-R	RH FERT TUBE W.A., NH3, LIQ., & VAPOR
3	1	2505-205	5/16-18 X 3/4 CARBOLT G5 ZP

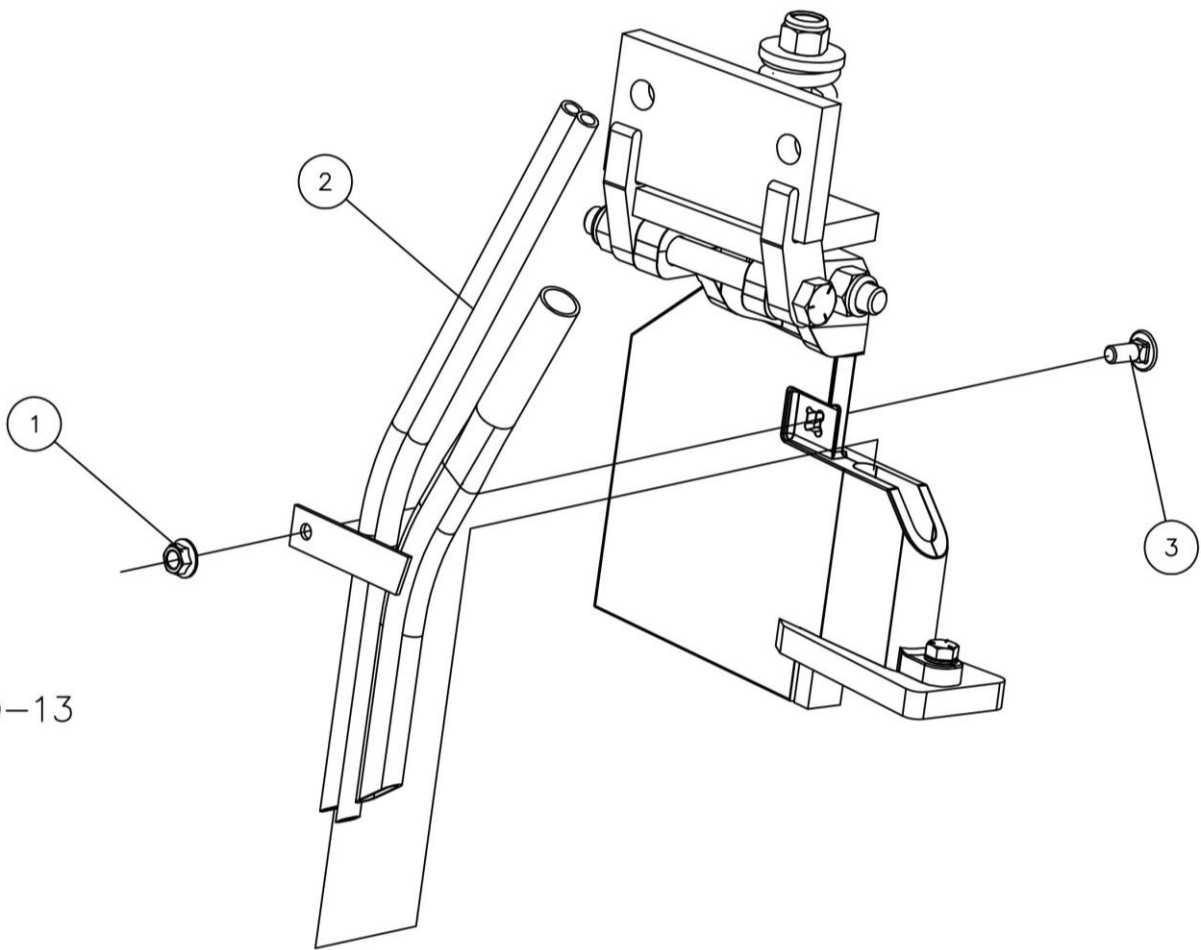

1800-13

PARTS IDENTIFICATION

2987-044-R

RH FERT KIT, VAPOR ONLY

DET	QTY	PART NO.	DESCRIPTION
1	1	2520-206	5/16-18 FLANGE LOCK NUT
2	1	2987-251-R	RH FERT TUBE W.A., VAPOR ONLY
3	1	2505-205	5/16-18 X 3/4 CARBOLT G5 ZP
4	1	2987-414	3/4 PLUG

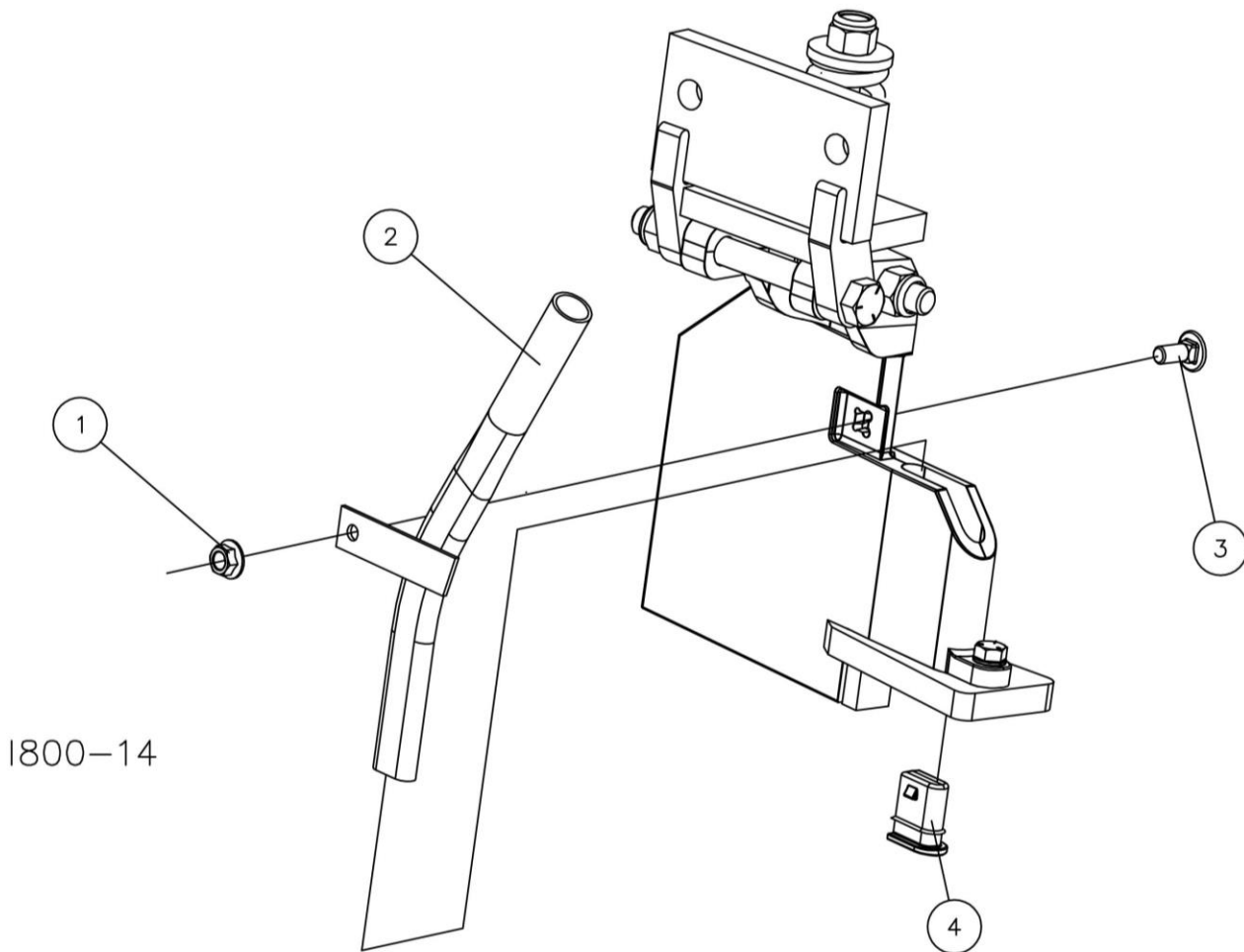

PARTS IDENTIFICATION

2987-046
1/2" LIQ. MAGNUM KIT

DET	QTY	PART NO.	DESCRIPTION
1	1	2520-206	5/16-18 FLANGE LOCK NUT
2	1	2987-252	1/2" LIQ TUBE W.A
3	1	2505-206	5/16-18 X 1 CARBLT GR5 ZP
4	1	2987-412	FULL PLUG

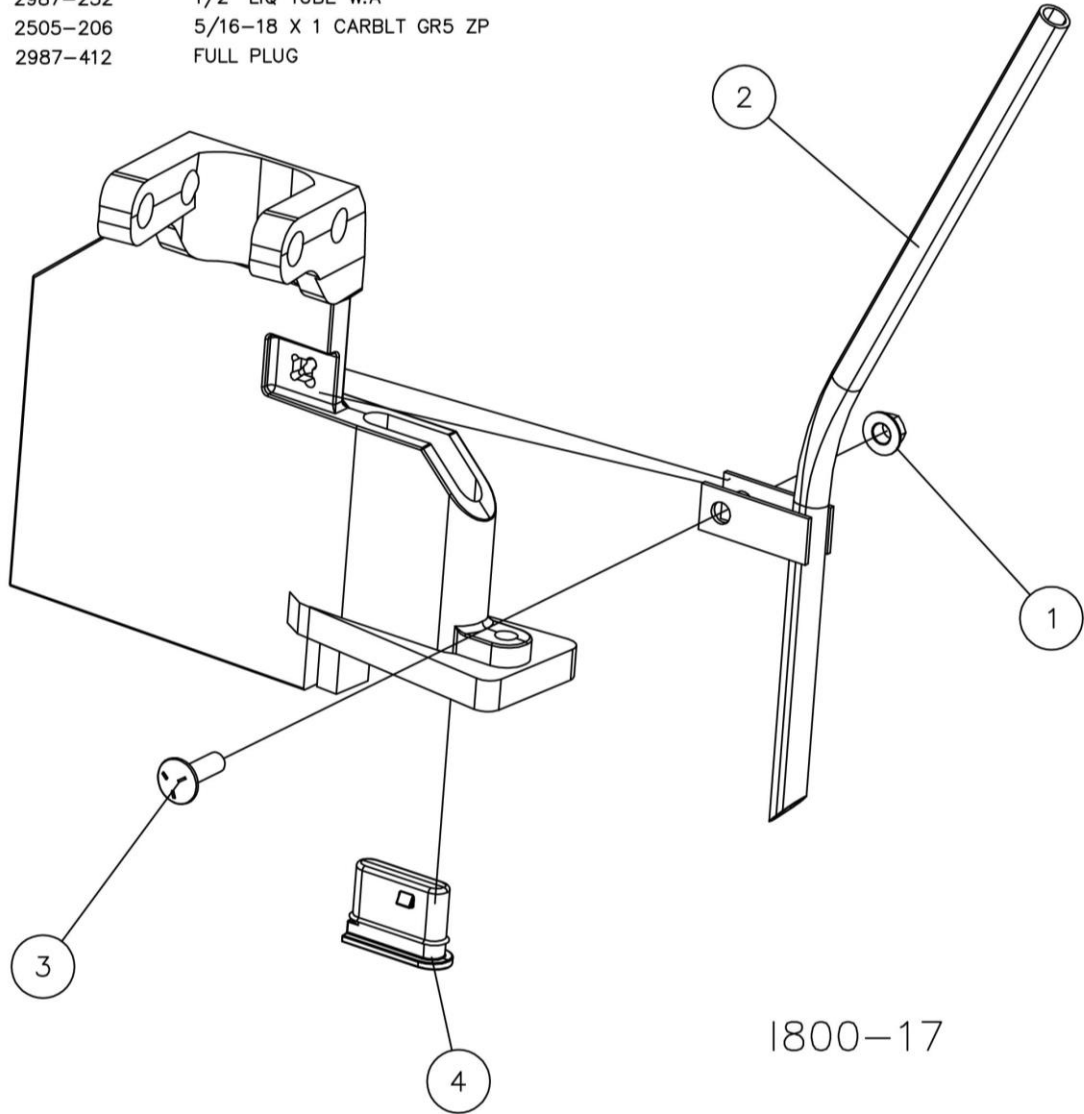

1800-17

PARTS IDENTIFICATION

2987-047 1/2" DUAL LIQ. MAGNUM KIT

DET	QTY	PART NO.	DESCRIPTION
1	1	2520-206	5/16-18 FLANGE LOCK NUT
2	1	2987-253	1/2" DUAL LIQ TUBE W.A
3	1	2505-206	5/16-18 X 1 CARBLT GR5 ZP
4	1	2987-414	3/4 PLUG

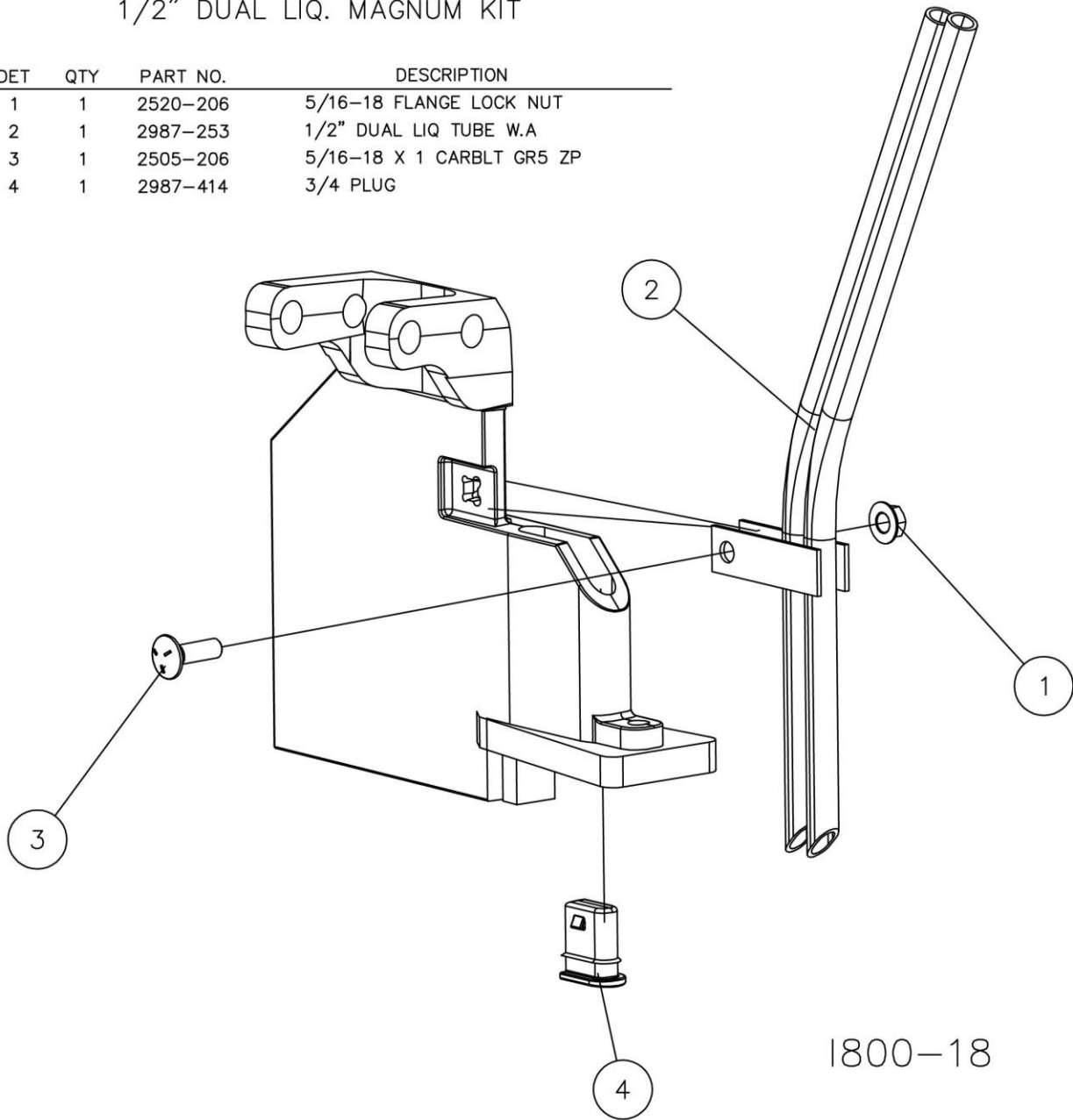

PARTS IDENTIFICATION

2987-050
DRY FERT. KIT, MAGNUM

DET	QTY	PART NO.	DESCRIPTION
1	1	2520-206	5/16-18 FLANGE LOCK NUT
2	1	2987-260	DRY TUBE W.A., MAGNUM
3	1	2505-206	5/16-18 X 1 CARBLT GR5 ZP

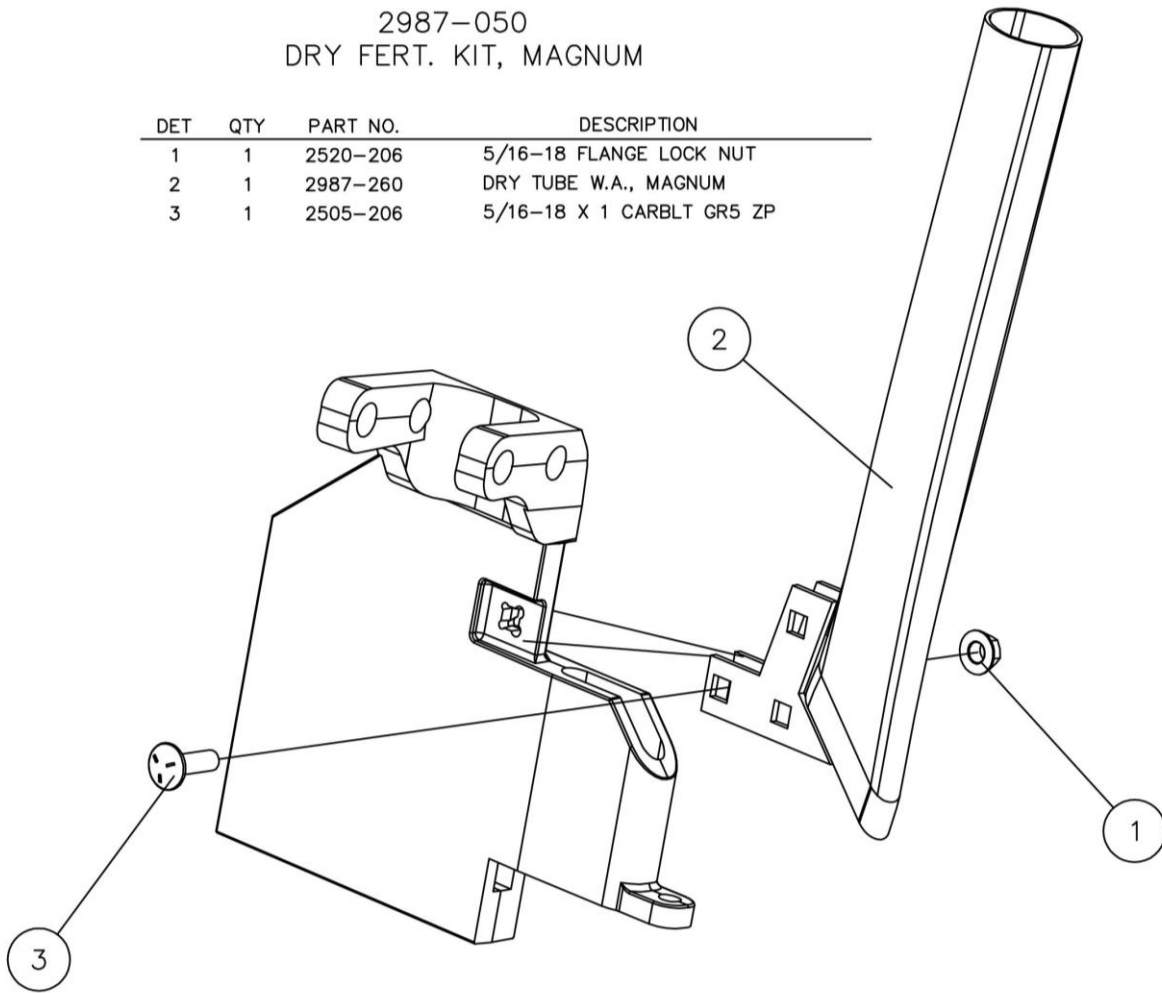

1800-19

PARTS IDENTIFICATION

2987-051
DRY/NH3 FERT. KIT, MAGNUM

DET	QTY	PART NO.	DESCRIPTION
1	1	2520-206	5/16-18 FLANGE LOCK NUT
2	1	2987-261	DRY/NH3 TUBE W.A., MAGNUM
3	1	2505-206	5/16-18 X 1 CARBLT GR5 ZP
4	1	2987-412	FULL PLUG

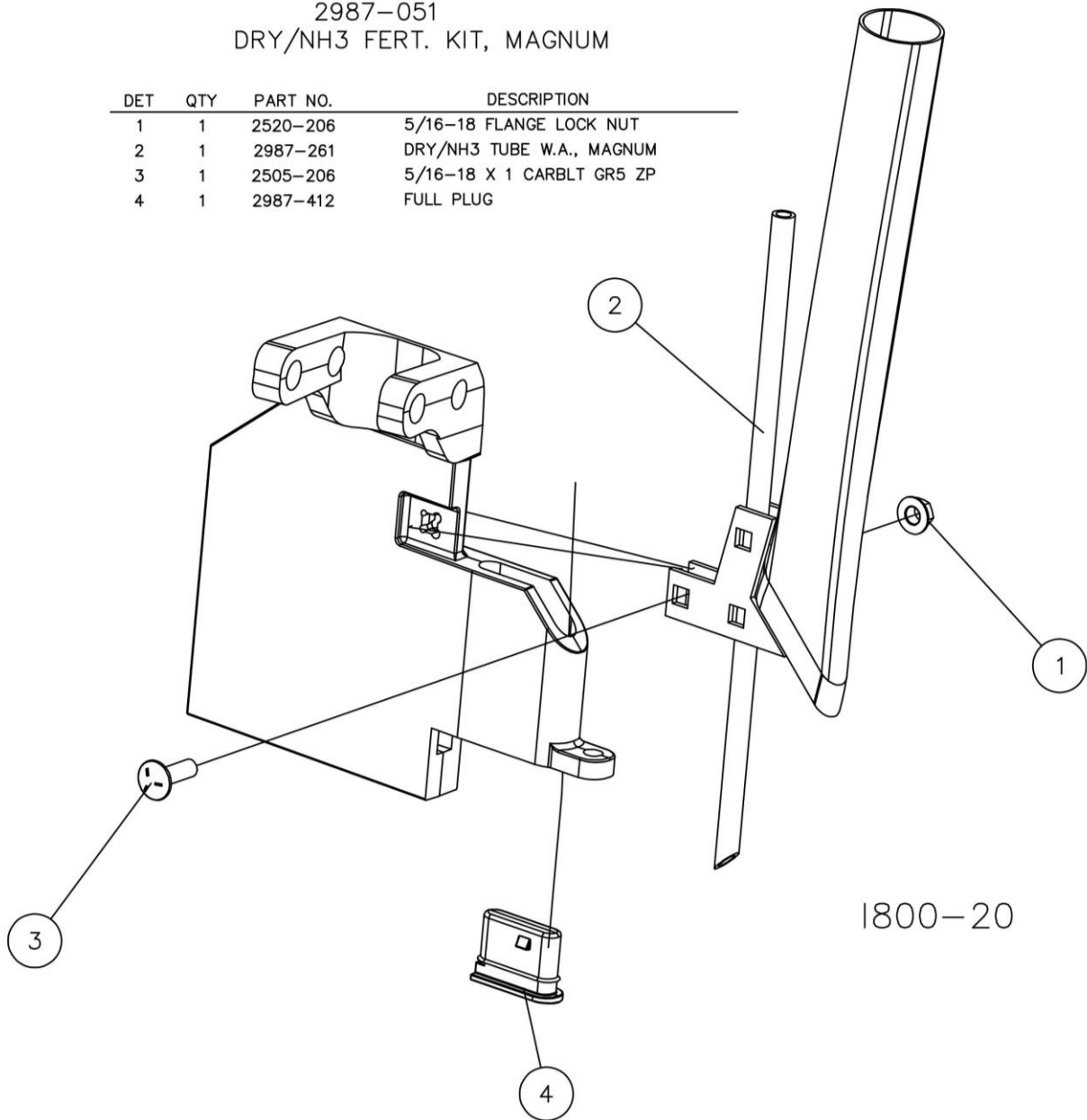

PARTS IDENTIFICATION

2987-052
DRY/NH3/VAPOR FERT. KIT, MAGNUM

DET	QTY	PART NO.	DESCRIPTION
1	1	2520-206	5/16-18 FLANGE LOCK NUT
2	1	2987-262	DRY/NH3/VAPOR TUBE W.A., MAGNUM
3	1	2505-206	5/16-18 X 1 CARBLT GR5 ZP
4	1	2987-412	FULL PLUG

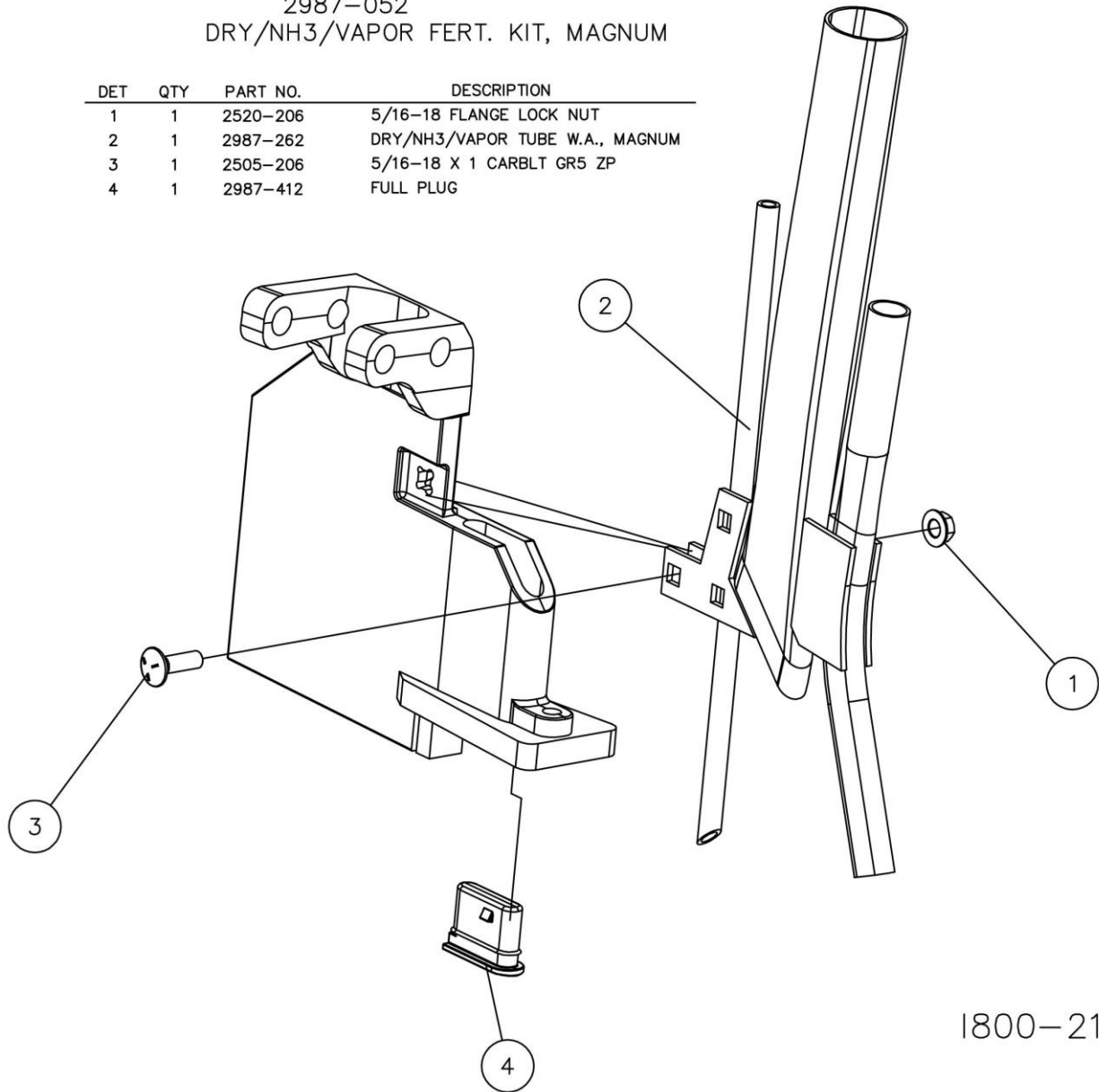

1800-21

PARTS IDENTIFICATION

2987-045-R

2987-045-L

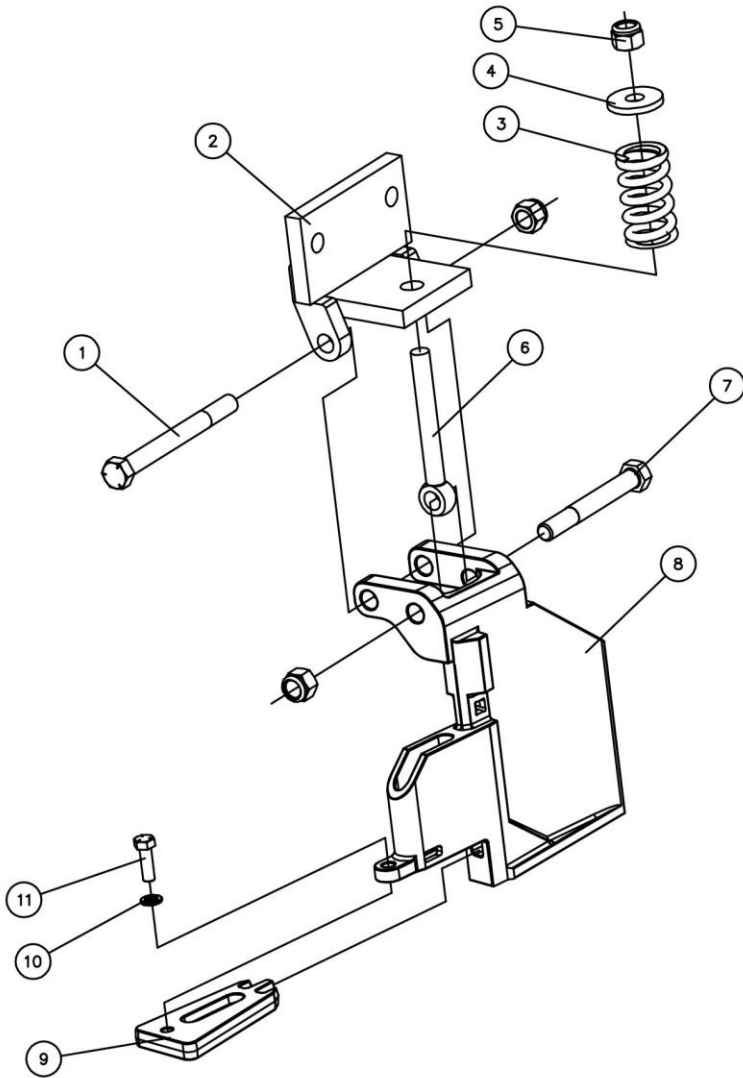

DET	QTY	PART NO.	DESCRIPTION
1	1	2502-362	1/2-13 X 5 HHCS GR. 5 Z
2	1	3000-251	SIDE KNIFE MOUNT W.A.
3	1	3000-344	2-1/2" SPRING#LHL-1500B-2,B
4	1	2527-330	1/2IDX1 1/2 OD X 7 GA MA BU
5	3	2520-363	1/2-13 NYL INSERT LOCKNUT Z
6	1	2570-447	EYEBOLT, 1/2-13 X 4-1/4
7	1	2502-364	1/2-13 X 4 HHCS GR. 5 ZP
8	1	2987-406	RH SIDE KNIFE CASTING, W/ CARBIDE (SHOWN)
	1	2987-407	LH SIDE KNIFE CASTING, W/ CARBIDE
9	1	2987-250-R	RH BEAVERTAIL W.A. (SHOWN)
	1	2987-250-L	LH BEAVERTAIL W.A.
10	1	2525-201	5/16 MED. LOCKWASHER ZP
11	1	2502-198	5/16-18 X 1 HHCS GR.5 ZP

1800-15

PARTS IDENTIFICATION

2987-144

TRI-SPOKE WHEEL ASSEMBLY

DET	QTY	PART NO.	DESCRIPTION
1	1	2520-452	5/8-11 HEXNUT ZP
2	1	2525-451	5/8 MED LOCKWASHER ZP
3	1	2987-145	TRI SPOKE WHEEL ASS'Y
4	3	2526-453	5/8 SAE FLATWASHER ZP
5	1	2987-401	GAUGE WHEEL SPACER
6	1	2502-327	5/8-11 X 5 HHCS GR.5 ZP
7	1	2987-244	NH3 MAGNUM GAUGE WHEEL ARM W.A.
8	1	2565-366	AVENGER COULTER DECAL
9	1	2502-333	5/8-11 X 9 HHCS GR. 5 ZP (NOT INCLUDED IN -144 KIT)
10	1	2987-392	3.763" INNER BUSHING (NOT INCLUDED IN -144 KIT)
11	1	2526-451	5/8 STD FLATWASHER ZP (NOT INCLUDED IN -144 KIT)
12	1	2520-459	5/8-11 LOCK HEX NUT, GR A, ZP (NOT INCLUDED IN -144 KIT)
13	1	2502-294	1/2-13 X 1-1/2 HHCS GR5 ZP (NOT INCLUDED IN -144 KIT)
14	1	2526-351	1/2 STANDARD FLATWASHER ZP (NOT INCLUDED IN -144 KIT)
15	1	2986-332	5/16 CHAIN 2 LINKS (NOT INCLUDED IN -144 KIT)
16	1	2520-357	1/2-13 LOCK HEX NUT, GR A, ZP (NOT INCLUDED IN -144 KIT)

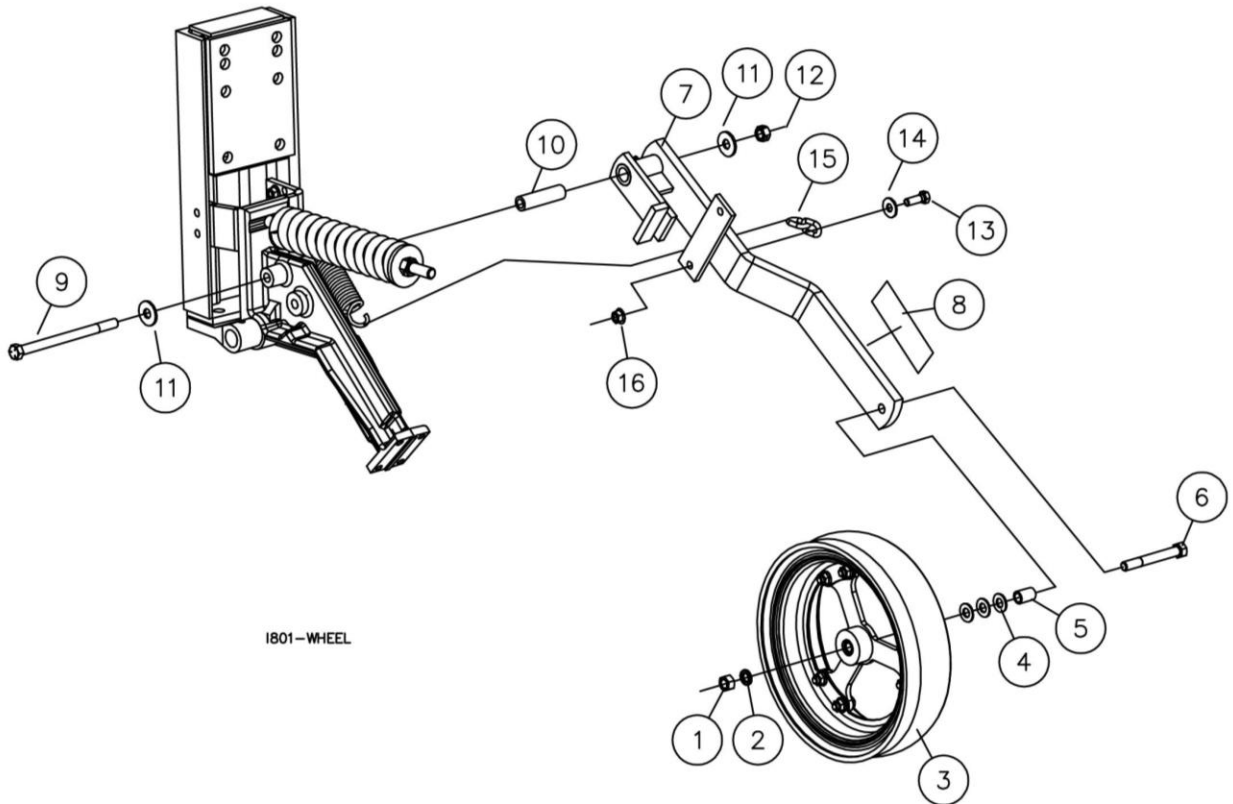

PARTS IDENTIFICATION

1801-WHEEL ASSEMBLY

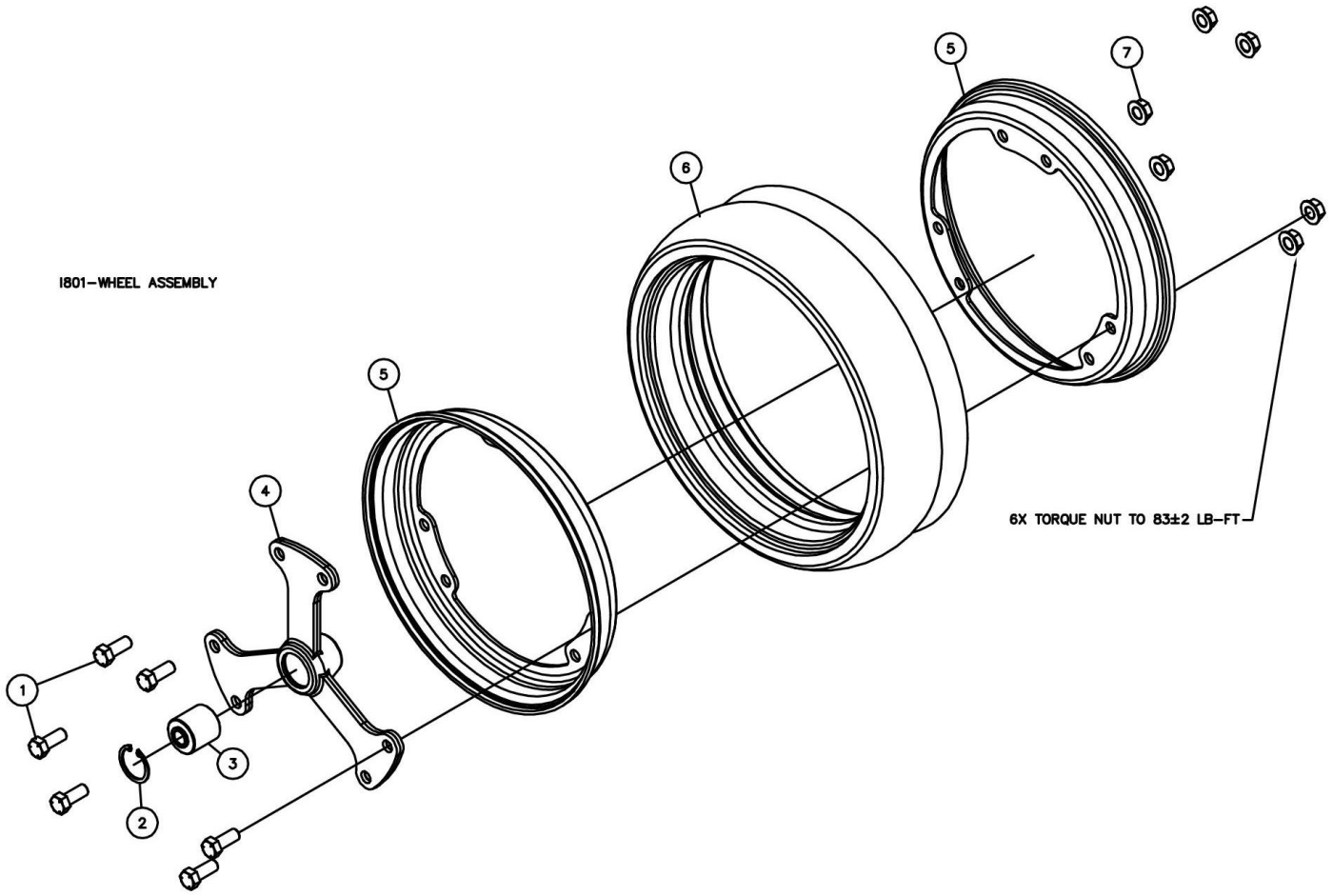

2987-145 TRI-SPOKE WHEEL ASSEMBLY

DET	QTY	PART NO.	DESCRIPTION
1	6	2502-293	1/2"-13 X 1-1/4" HHCS GR5
2	1	2550-526	SNAP RING, 40MM
3	1	2570-069	40MM BEARING
4	1	2987-380	TRI-SPOKE HUB
5	2	2570-087	TRI-SPOKE WHEEL HALF
6	1	2987-399	4.5" X 16" OFFSET SMOOTH CROWN TIRE
7	6	2520-361	1/2" FLANGE NUT

UPDATED 01/07/16

PARTS IDENTIFICATION

NOTE: REMOVE THE EXISTING 2" BOLTS OUT OF MOUNTING BRACKET AND INSTALL DETAIL #3 ON THE RIGHT SIDE OF COULTER MOUNTING BRACKET FOR A RIGHT HAND ASSEMBLY AS SHOWN.

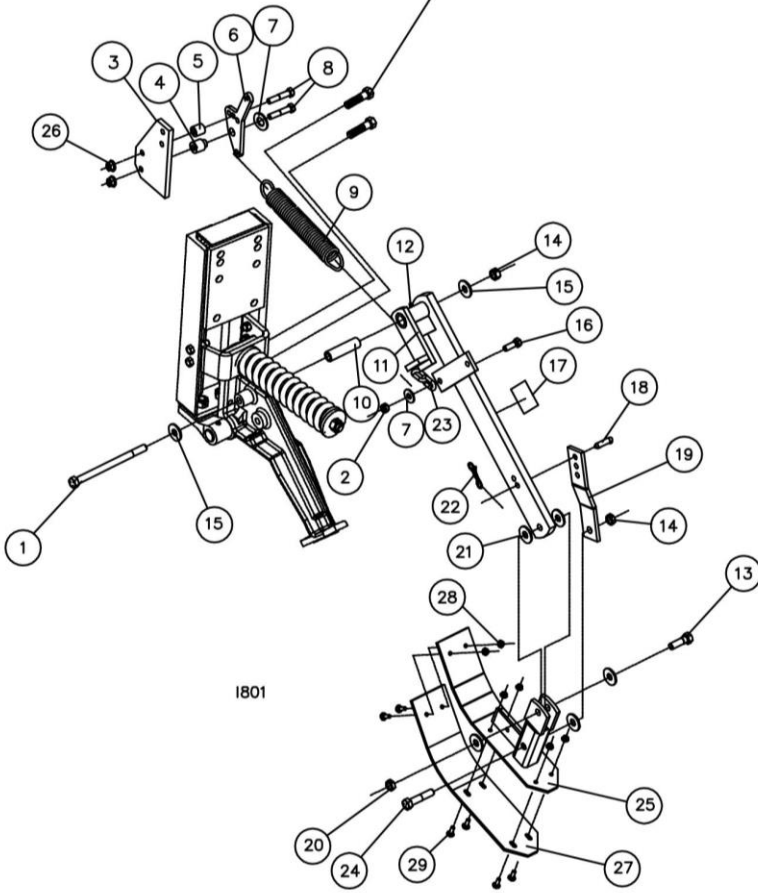

SKID SHOE ASSEMBLY, 22"

KEY	QTY	PART NO.	DESCRIPTION
1	1	2502-333	5/8-11 X 9 HHCS GR. 5 ZP
2	1	2520-357	1/2-13 LOCK HEX NUT ZP
3	1	2986-327	LEVER MOUNTING PLATE
4	1	2986-324	LEVER PIVOT BUSHING
5	1	2960-372	SPRING STOP, ZYD.
6	1	2986-326	SPRING ADJUSTING LEVER
7	2	2526-351	1/2 STANDARD FLATWASHER ZP
8	2	2502-296	1/2-13 X 2-1/2 HHCS GR. 5 ZP
9	1	6000-525	CLOSE WHEEL SPRING, PAINTED
10	1	2987-392	3.763" INNER BUSHING
11	1	2987-238	NH3 MAGNUM SKID ARM W.A.
12	1	2533-110	1/4-28 ZERK, STRAIGHT SELF-TAP
13	1	2502-393	5/8-11 X 2 1/2HHCS GR 5 ZP
14	2	2520-459	5/8-11 LOCK HEX NUT ZP
15	2	2526-451	5/8 STANDARD FLATWASHER ZP
16	1	2502-294	1/2-13 X 1-1/2 HHCS GR. 5 ZP
17	1	2565-366	AVENGER COULTER DECAL
18	1	2967-381	COMBO ADJUSTMENT PIN ZP
19	1	2987-391	SKID SHOE ADJUSTMENT PLATE
20	1	2520-467	5/8-11 HEX LOCK NUT, JAM ZP
21	4	2527-563	5/8ID X1"OD X14GA MACH BUSH ZP
22	1	2570-448	1/8 BOWTIE LOCKING COTTER ZYD
23	1	2986-332	5/16 CHAIN 2 LINKS
24	1	2502-324	5/8-11 X 3-1/2 HHCS GR5 ZP
25	1	2987-239	22" MAGNUM SKID SHOE W.A.
26	2	2520-361	1/2-13FLANGE WHZLCK HXNT ZP
27	1	2987-384	4 1/4" POLY SKID SHOE, SHORT
28	6	2520-206	5/16-18 FLANGE LOCK NUT
29	6	2505-206	5/16-18 X 1" CAR BOLT GR 5 ZYD

PARTS IDENTIFICATION

2987-027A-L-ST-A

LH Sealer Kit Sharktooth

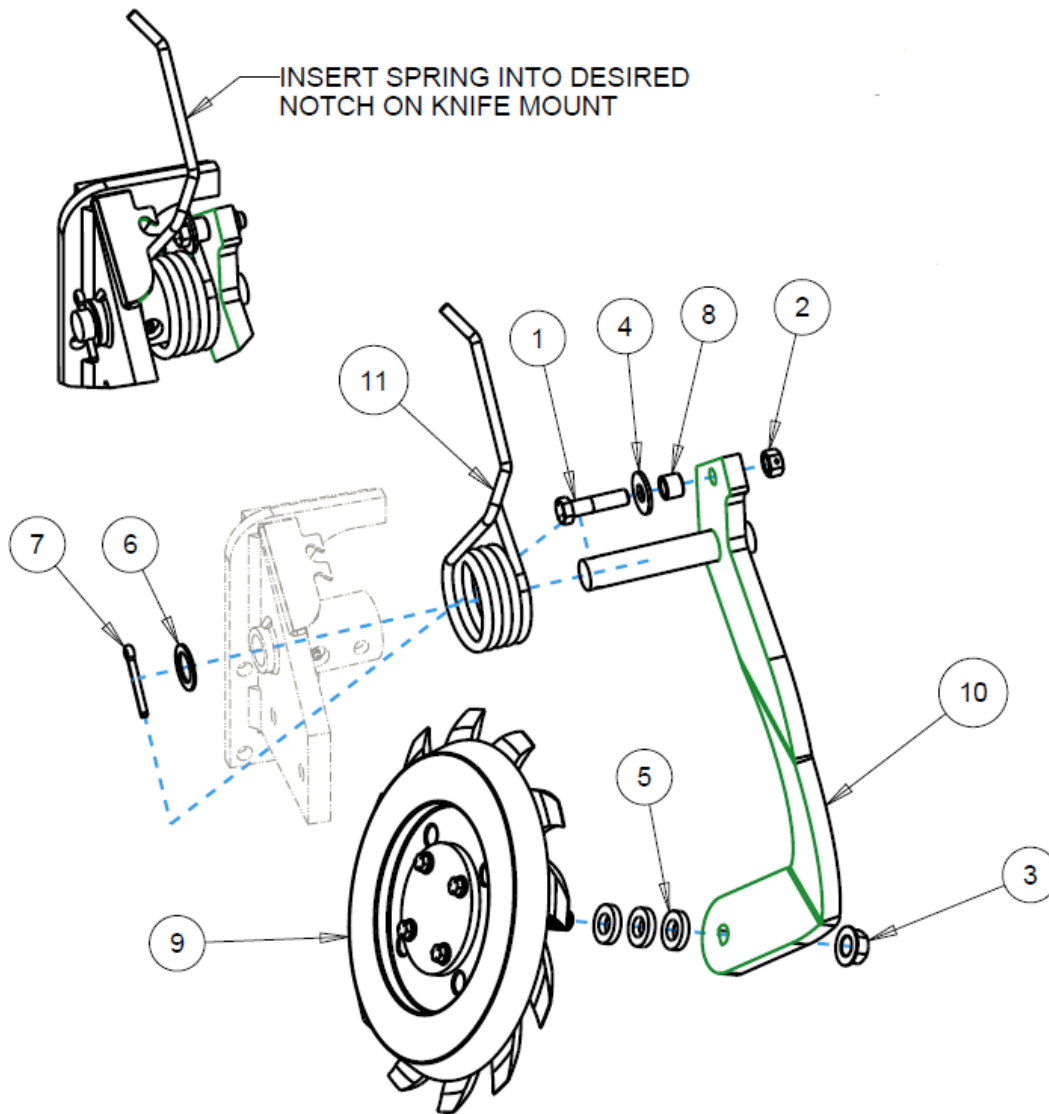

ITEM	PART NO	DESCRIPTION	QTY
1	2502-351	1/2 -13 X 2 HHCS GRADE 5	1
2	2520-357	1/2-13 LOCK HEX NUT GRADE A	1
3	2520-465	5/8-11 FLANGE NUT GRADE 8	1
4	2526-351	1/2 STANDARD FLAT WASHER	1
5	2526-455	WASHER 21/32" X 1-1/4" X 1/4"	3
6	2527-564	1" ID X 1-1/2" OD X 14 GA MACHINE WASHER	1
7	2531-125	1/4 X 1-3/4" COTTER PIN	1
8	2967-622	9/16" SPACER	1
9	2987-142-L	LEFT HAND CLOSER WHEEL ASSEMBLY	1
	2502-225	5/16-18 X 1-1/2 FLANGE HEAD BOLT GRADE 5	4
	2571-286	SHARK TOOTH WHEEL	1
	2965-501	HUB ASSEMBLY 2.406 SPINDLE	1
	2965-503	HUB CAP	1
	2987-396	CAST PRESS WHEEL	1
10	2987-242	LEFT HAND ARM	1
11	2987-395-L	LEFT HAND TORSION SPRING	1

PARTS IDENTIFICATION

2987-027A-R-ST-A

RH Sealer Kit Sharktooth

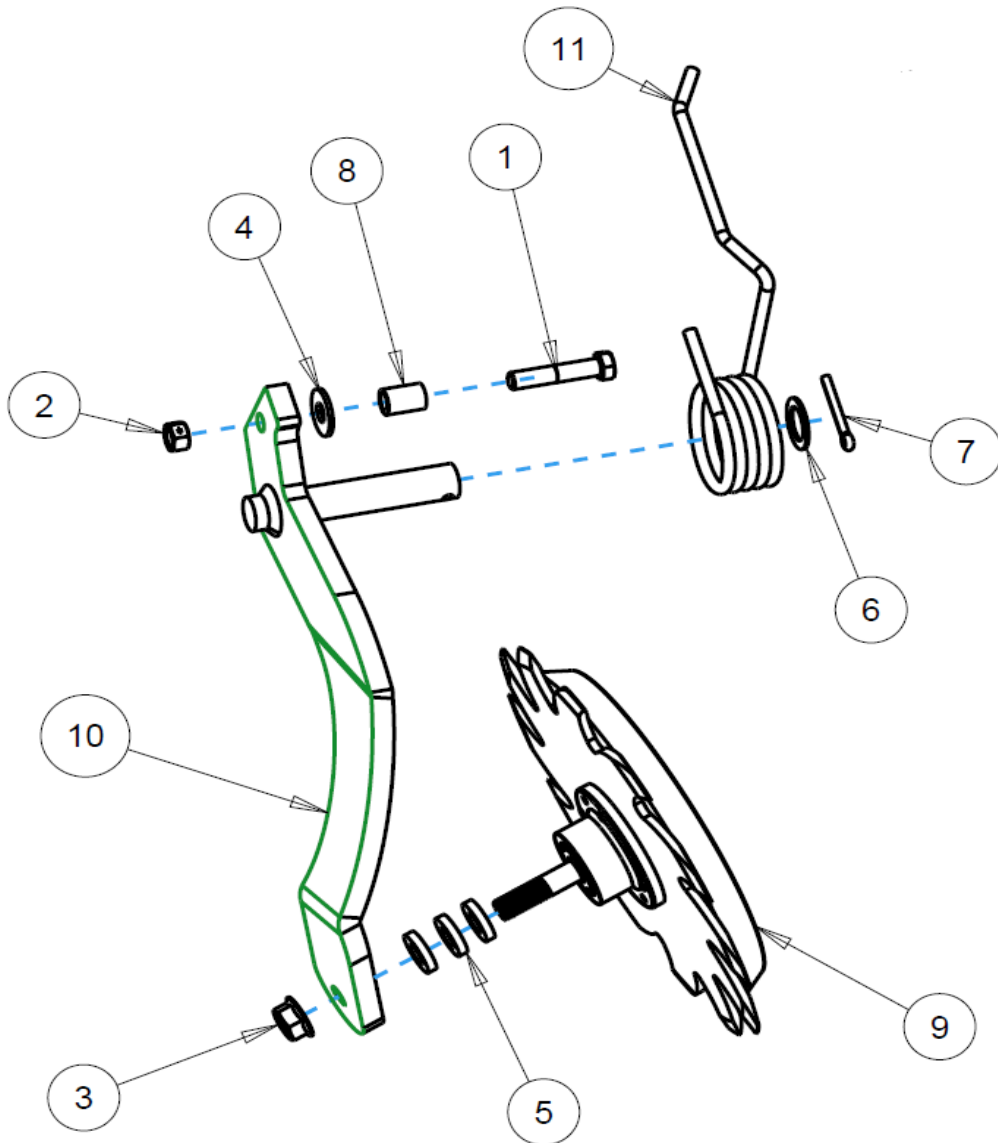

ITEM	PART NO	DESCRIPTION	QTY
1	2502-351	1/2 -13 X 2 HHCS GRADE 5	1
2	2520-357	1/2-13 LOCK HEX NUT GRADE A	1
3	2520-465	5/8-11 FLANGE NUT GRADE 8	1
4	2526-351	1/2 STANDARD FLAT WASHER	1
5	2526-455	WASHER 21/32" X 1-1/4" X 1/4"	3
6	2527-564	1" ID X 1-1/2" OD X 14 GA MACHINE WASHER	1
7	2531-125	1/4 X 1-3/4" COTTER PIN	1
8	2967-622	9/16" SPACER	1
9	2987-142-R	RIGHT HAND CLOSER WHEEL ASSEMBLY	1
	2502-225	5/16-18 X 1-1/2 FLANGE HEAD BOLT GRADE 5	4
	2571-286	SHARK TOOTH WHEEL	1
	2965-501	HUB ASSEMBLY 2.406 SPINDLE	1
	2965-503	HUB CAP	1
	2987-396	CAST PRESS WHEEL	1
10	2987-241	RIGHT HAND ARM	1
11	2987-395-R	RIGHT HAND TORSION SPRING	1

PART IDENTIFICATION

2987-142-L (SHOWN) & 2987-142-R CLOSING WHEEL ASSEMBLY

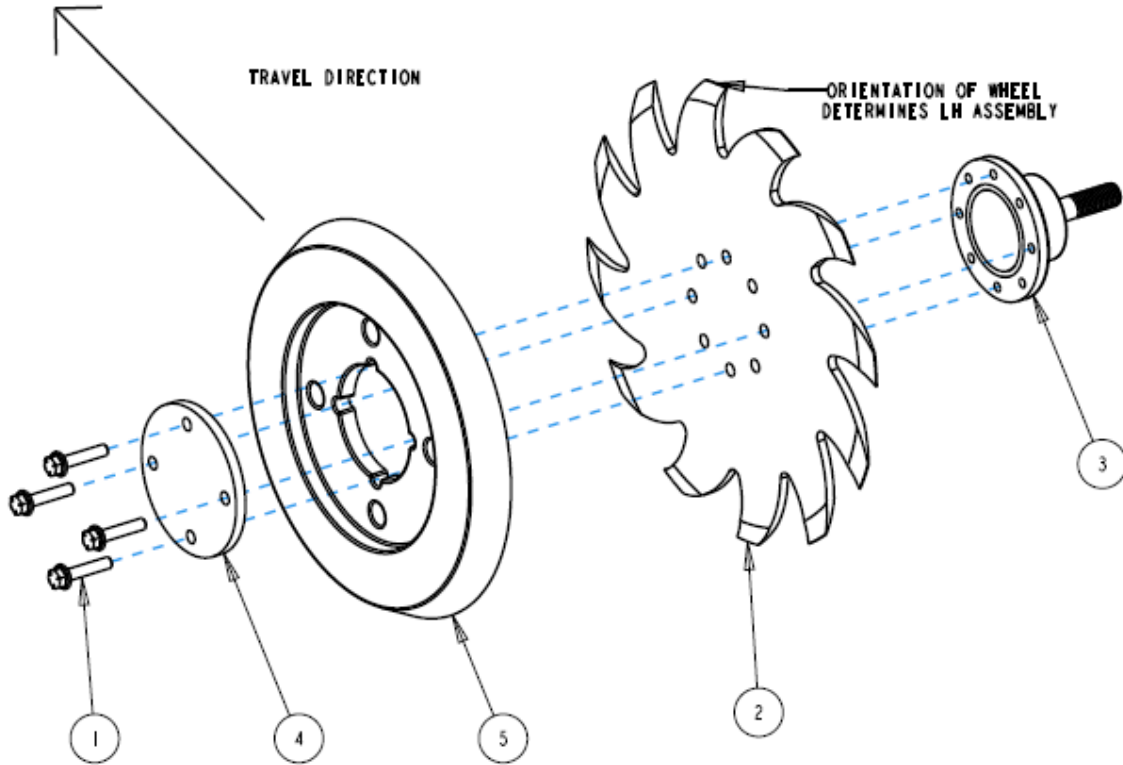

ITEM	PART NO.	DESCRIPTION	QTY.
1	2502-225	5/16-18 X 1-1/2 HHFS GR. 5	4
2	2571-286	SHARKTOOTH WHEEL	1
3	2965-501	HUB ASSEMBLY 2.406" SPINDLE	1
4	2965-503	HUB CAP	1
5	2987-396	CAST PRESS WHEEL	1

MANUFACTURED 06/2021 – PRESENT

PART IDENTIFICATION

2987-142-L (SHOWN) & 2987-142-R
CLOSING WHEEL ASSEMBLY

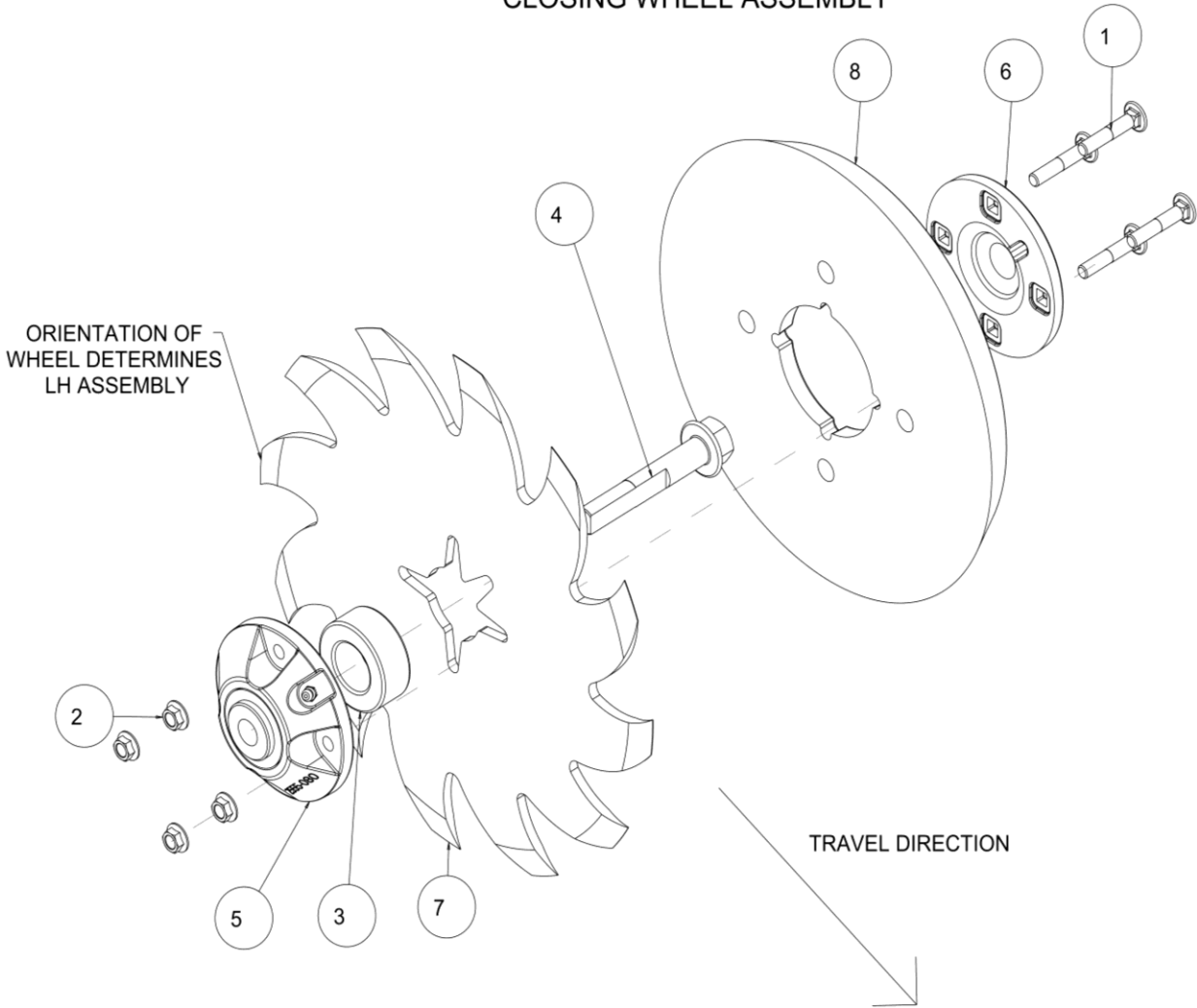

ITEM	PART NO.	DESCRIPTION	QTY.
1	2502-209	5/16-18 X 1-13/4 GR. 5	4
2	2520-206	5/16-18 FLANGE LOCK NUT	4
3	2570-594	BEARING	1
4	2570-742	D-BOLT FLANGED 5/8-11 X 3.812" GR. 8	1
5	2965-128	HUB ASSEMBLY	1
	2550-069	SEAL	1
	2570-594	BEARING	1
	2570-715	INSERT	1
	2965-351	HUB	1
6	2965-352	HUB CAP	1
7	2967-602	13" SHARK TOOTH	1
8	2987-396	PRESS WHEEL	1

MANUFACTURED 02/2010 – 06/2021

PARTS IDENTIFICATION
2965-120
HUB UPDATE KIT

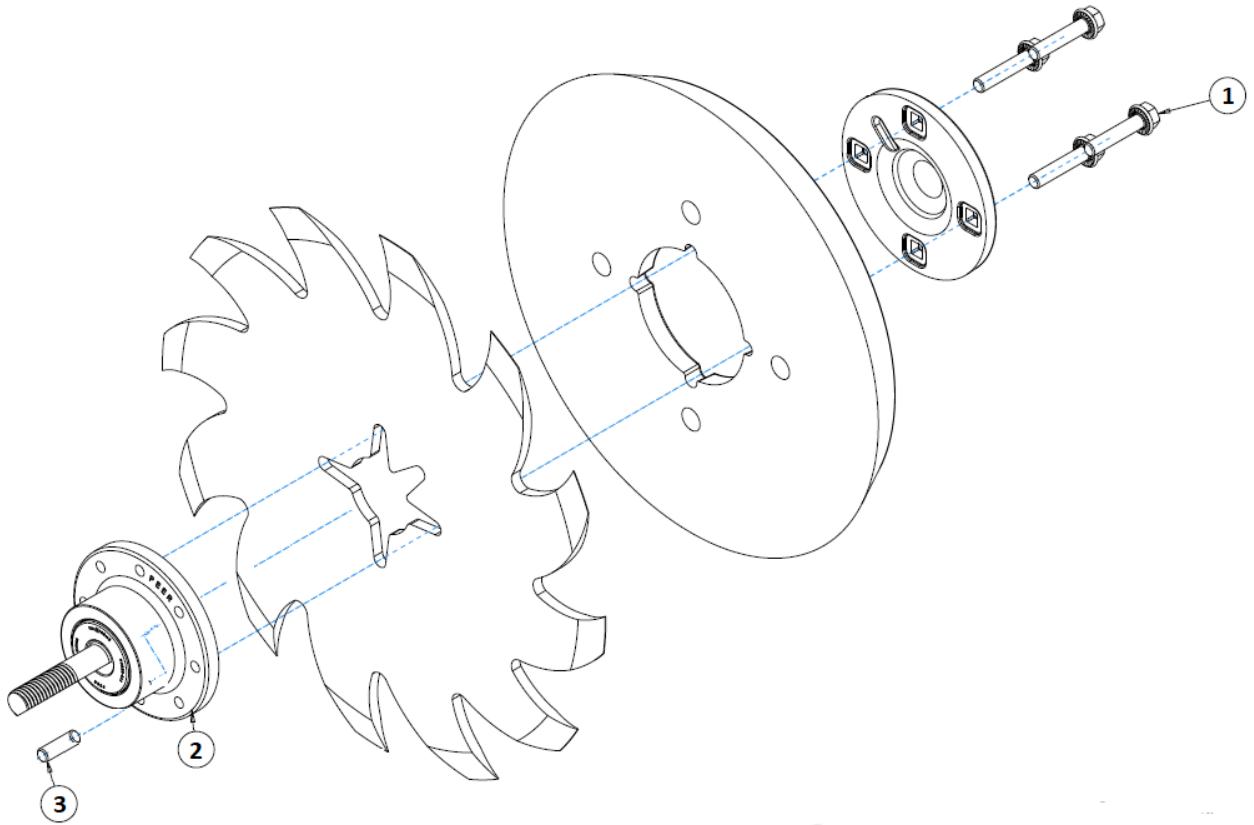

ITEM	PART NO.	DESCRIPTION	QTY.
1	2502-225	5/16-18 X 1-1/2 HHFS GR. 5	4
2	2965-501	HUB ASSEMBLY 2.406" SPINDLE	1
3	2940-560	SET SCREW .313-18 X .75	1

NOTES

NOTES



A Tradition of Solutions since 1930

Yetter Farm Equipment Co

PO BOX 358 109 S. McDonough

Colchester, IL 62326-0358

Phone: 309-776-4111

Toll Free: 800-447-5777

Email: info@yetterco.com

For updated models and manuals visit the Yetter website:

www.yetterco.com

© Yetter Farm Equipment Co. All Rights Reserved

2565-758_REV_R  08/2024