



2982-001

V.T.A.™

VERTICAL TILLAGE ATTACHMENT
SET-UP AND PARTS MANUAL

2565-732_REV_D 08/2024



YETTER MANUFACTURING CO.
FOUNDED 1930

Colchester, IL 62326-0358
Toll free: 800/447-5777
309/776-3222 (Fax)
Website: www.yetterco.com
E-mail: info@yetterco.com

YETTER

FOREWORD

You've just joined an exclusive but rapidly growing club.
For our part, we want to welcome you to the group and thank you for buying a Yetter product.

We hope your new Yetter products will help you achieve both goals-increase your productivity and increase your efficiency so that you may generate more profit.

This operator's manual has been designed into four major sections: Foreword, Safety Precautions, Installation Instructions and Parts Breakdown.

This **SAFETY ALERT SYMBOL** indicates important safety messages in the manual. When you see this symbol, be alert to the possibility of **PERSONAL INJURY** and carefully read the message that follows.



DANGER: Indicates an imminently hazardous situation which, if not avoided "will" result in death or serious injury. This signal word is to be limited to the most extreme situations



WARNING: Indicates a potentially hazardous situation which, if not avoided, "could" result in death or serious injury.



CAUTION: Indicates a potentially hazardous situation, which if not avoided, "may" result in minor or moderate injury. It may also be used to alert against unsafe practices.



NOTICE: Indicates information considered important, but not hazard related (e.g., messages relating to property damage).

It is the responsibility of the user to read the operator's manual and comply with the safe and correct operating procedure and to lubricate and maintain the product according to the maintenance schedule in the operator's manual.

The user is responsible for inspecting his machine and for having parts repaired or replaced when continued use of the product would cause damage or excessive wear to the other parts.

It is the user's responsibility to deliver his machine to the Yetter dealer who sold him the product for service or replacement of defective parts, which are covered by the warranty policy.

If you are unable to understand or follow the instructions provided in this publication, consult your local Yetter dealer or contact:

YETTER MANUFACTURING CO.
309/776-4111
800/447-5777
309/776-3222 (FAX)
Website: www.yetterco.com
E-mail: info@yetterco.com

WARRANTY

Yetter Manufacturing warrants all products manufactured and sold by it against defects in material. This warranty being expressly limited to replacement at the factory of such parts or products as shall appear to be defective after inspection. This warranty does not obligate the Company to bear cost of labor in replacement of parts. It is the policy of the Company to make improvements without incurring obligations to add them to any unit already sold. No warranty is made or authorized to be made, other than herein set forth. This warranty is in effect for one year after purchase.

DEALER: _____

Yetter Manufacturing warrants its own products only and cannot be responsible for damages to equipment on which mounted.



SAFETY PRECAUTIONS



A brief description of signal words that may be used in this manual:

DANGER: Indicates an imminently hazardous situation which, if not avoided “will” result in death or serious injury. This signal word is to be limited to the most extreme situations.

WARNING: Indicates a potentially hazardous situation which, if not avoided, “could” result in death or serious injury.

CAUTION: Indicates a potentially hazardous situation, which if not avoided, “may” result in minor or moderate injury. It may also be used to alert against unsafe practices.

NOTICE: Indicates information considered important, but not hazard related (e.g., messages relating to property damage).

Consult your implement and tractor operator’s manual for correct and safe operating practices. Be aware of towed implement width and allow safe clearance.

Safety decals are placed on the implement to alert the operator and others to the risk of personal injury or unsafe operation during normal operations and servicing.

1. The safety decals must be kept clean and in good condition to ensure that they are legible.
2. Safety decals must be replaced if they are missing or illegible.
3. When components are replaced during repair or servicing, check that the new components include the necessary safety signs.
4. Replacement safety decals may be obtained from your local dealer.



WARNING

Read these instructions carefully to acquaint yourself with the Equipment. Working with unfamiliar equipment can lead to accidents.

Never park the equipment on a steep incline or leave the equipment running unattended.

Never clean, lubricate or adjust a machine that is in motion.

Always check that straps are secure.

Make sure latches are in pinned position when moving equipment.

Do not allow children to operate this equipment.

Do not allow riders on the equipment, trailer and/or pick-up.

Use speed and caution dictated by the terrain being traversed. Do not operate on any slope steep enough to cause tipping or loss of control.

Read and understand the operator’s manual and require all other persons who will operate the equipment to do the same.

If operating on public roadways, where legal, be certain all lighting is operating properly and observe all traffic laws.

Beware of increased stopping distances and control effort when operating with implements attached.

Be familiar with all controls and be prepared to stop equipment quickly in an emergency.

FAILURE TO HEED MAY RESULT IN PERSONAL INJURY OR DEATH.

TABLE OF CONTENTS



Forward.....	pg. 2
Warranty.....	pg. 2
Safety Information.....	pg. 2-3
Table of Contents.....	pg. 3
Torque Recommendations.....	pg. 4
Machine Application Guide.....	pg. 5
General Information.....	pg. 5
Installation Instruction.....	pg. 6-7
Operation.....	pg. 8
Maintenance.....	pg. 9
Parts Identification.....	pg. 10

BOLT TORQUE

READ THESE INSTRUCTIONS FIRST:

1. Improperly tightened bolts will result in damage, breakage, expense, and down time.
2. Always replace bolts with the specified grade and type.
3. Torque properly before first use of the machine and every 2-4 hours of use until you are sure bolts are staying tight.
4. The chart below is a guide for proper torque. Use it unless a specified torque is called out elsewhere in the manual.
5. Torque is the force you apply to the wrench handle or the cheater bar, times the length of the handle or bar.
6. Use a torque wrench whenever possible.

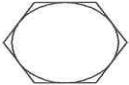
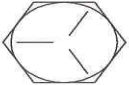
The following table shows torque in ft. lbs.

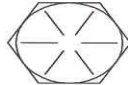
BOLT DIA. AND THREADS PER INCH	 GRADE 2	 OR  GRADE 5 A-325	 GRADE 8
3/8-16	25	35	50
7/16-14	35	55	80
1/2-13	55	85	125
9/16-12	75	125	175
5/8-11	105	170	235
3/4-10	185	305	425
7/8-9	170	445	690
1-8	260	670	1030
1 1/8-7	365	900	1460
1 1/4-7	515	1275	2060
1 3/8-6	675	1675	2700
1 1/2-6	900	2150	3500
1 3/4-5	1410	3500	5600

Lubricate all bearings and moving parts as assembled and make certain that they work freely.



WARNING: Never work around the toolbar / implement while in a raised position without using safety lockups.



CAUTION: The 2982 V.T.A.™ Vertical Tillage Attachment unit has sharp blades. Extra attention should be paid to lifting techniques while handling and or maneuvering the units during assembly. Failure to do so may lead to personal injury. Use heavy gloves while handling the blades during assembly and any time adjustments or maintenance operations are made to the units.

VERTICAL TILLAGE ATTACHMENT MACHINE APPLICATION GUIDE

The VTA is designed to be a universal fit for **most** all tillage shanks: 1-5/8" & 1-3/4" hole spacing with 7/16" holes and 2" & 2-1/4" hole spacing with 1/2" holes.

Here is a partial listing of manufacturers:

Allis-Chalmers, Amco, Anderson, Armstrong, Athens-Rhino, Baker, Bourgault, Brady, Brillion, Bush Hog, Calkins, Case, Case-IH, CCIL, CO-OP, Cockshutt, Crown, Crustbuster, Degelman, Deutz-Allis, DMI, Edwards, Fallow King, Fallow-Master, Farmhand, Flexi-Coil, Ford, Friggstad, Forrest City Do-All, Glencoe, Graham, Hesston, Hiniker, IHC, Ingram, Jeffery, John Deere, Kasco, Kelly, Kent, Kewanee, Krause, Landoll, Lely, M & W, Massey-Ferguson, Massey-Harris, McKee, Mel-Cam, Melroe-Clark, Minn-Toba, Mohawk, Morris, New Holland, Noble, Oliver, Renn, Rhino, Robin Nodwell, Roll-O-Cone, Roll-O-Flex, Schultz, Steiger, Sunflower, Taylor, Versatile, Victory, White, Wilbeck, Wil-Rich, Win-Power.

The Vertical Tillage Attachment has a wide variety of capabilities, making it ideal for use in the spring and the fall.

In the fall, it can be used to lightly till the soil and incorporate and size residue, setting the stage for the spring planting season. It is also a practical way to dry out wet soils. The Vertical Tillage Attachment works well in no-till conservation tillage, as well as conventional tillage operations, extending the growing season and creating better planting conditions. Vertical tillage prepares the soil to warm more quickly in early spring, energizing the seedbed for maximum growth and yield potential. In addition, the Vertical Tillage Attachment allows for shallow seedbed preparation, which decreases the risk of excess soil density below the root zone.

The Vertical Tillage Attachment is also an excellent addition to spring residue management. It increases planting efficiency, offers maximum yield potential, and performs well in all residue conditions. When wet cool fields delay spring planting, the Vertical Tillage Attachment is the perfect tool to use to dry and warm them. Fluffing and sizing the residue along with fracturing the soil speeds the drying process. The Vertical Tillage Attachment can be used as a surface crust breaker following heavy rains. Like all Yetter products, it is built tough to last, and even in high residue crops, such as wheat, corn, and soybeans, the Vertical Tillage Attachment delivers optimal performance, cutting heavy residue to enhance planter operation. In addition, it offers improved insect and disease control through residue sizing and disturbance.

Overall, the Vertical Tillage Attachment is a smart investment in that it has multiple uses, which will ultimately produce savings in terms of time and money. It also has a low operating cost per acre and can be used in a wider range of conditions than most tillage tools. It operates at a relatively high speed of 6 to 10 MPH, which saves time. Additionally, the Vertical Tillage Attachment allows for quick mixing of manure and soil to prevent loss of nutrients and control odor. It can also be used for very shallow incorporation of fertilizer and select herbicides.

The Vertical Tillage Attachment can be equipped with a wide selection of coulter blades. Spaced on 6" centers, the coulter blades can be matched to achieve the desired amount of tillage and residue sizing.

INSTALLATION INSTRUCTIONS

STEP 1. Install the hub/bracket assembly to the shank using the 2) 7/16" x 2-1/4" or 1/2" x 2-1/2" Plow bolts and 7/16" or 1/2" flange lock hex nuts.

STEP 2. Torque the bolts so that the mount plate will conform to curvature of the shank.

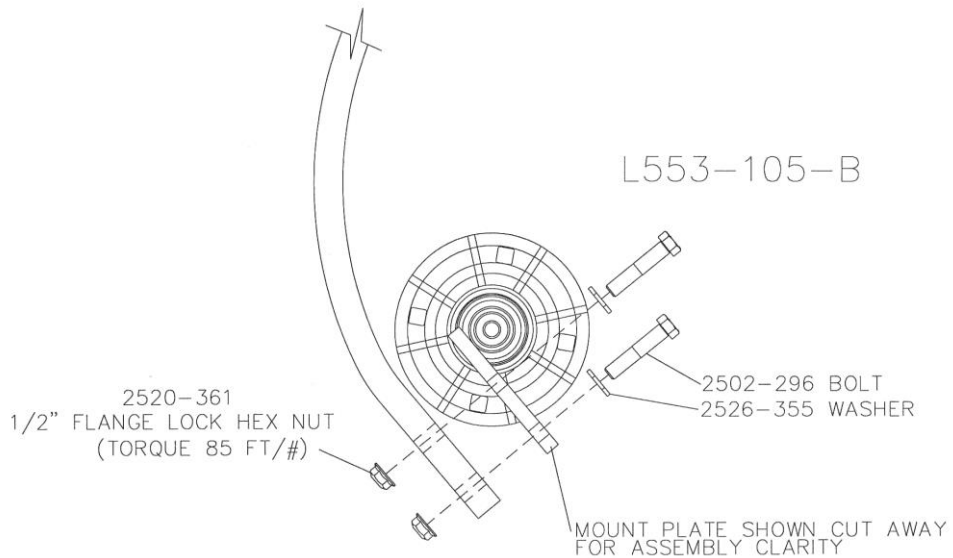
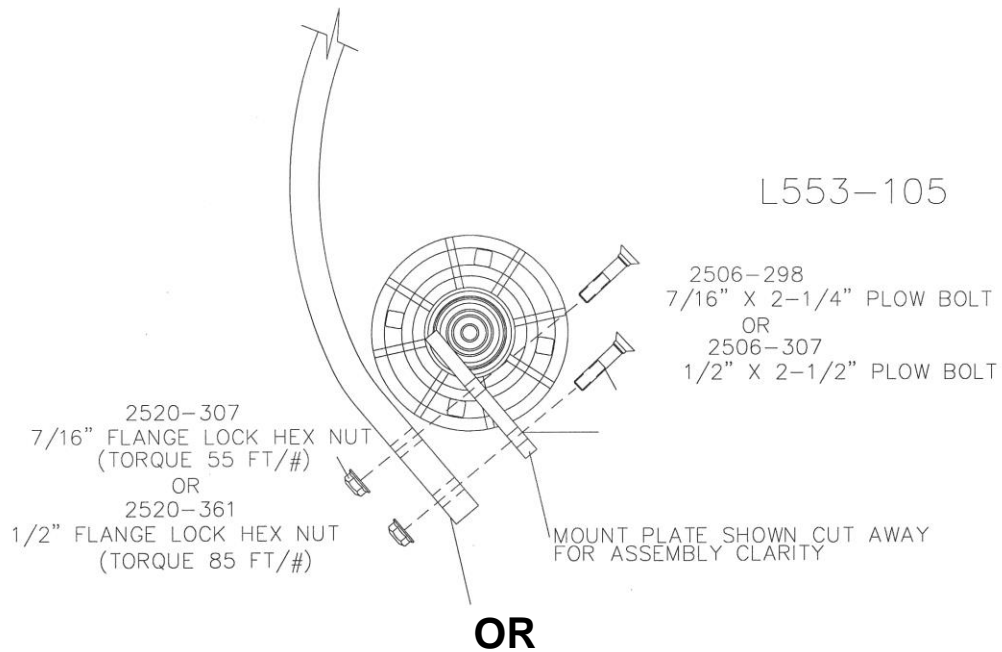

UPDATED 11/20/09

INSTALLATION INSTRUCTIONS

STEP 3. Attach the coultter blades and 2987-301 hubcap retainer to the hub/bracket assembly using the 8) 1/2" x 1-1/4" carriage bolts, lock washers and hex nuts.

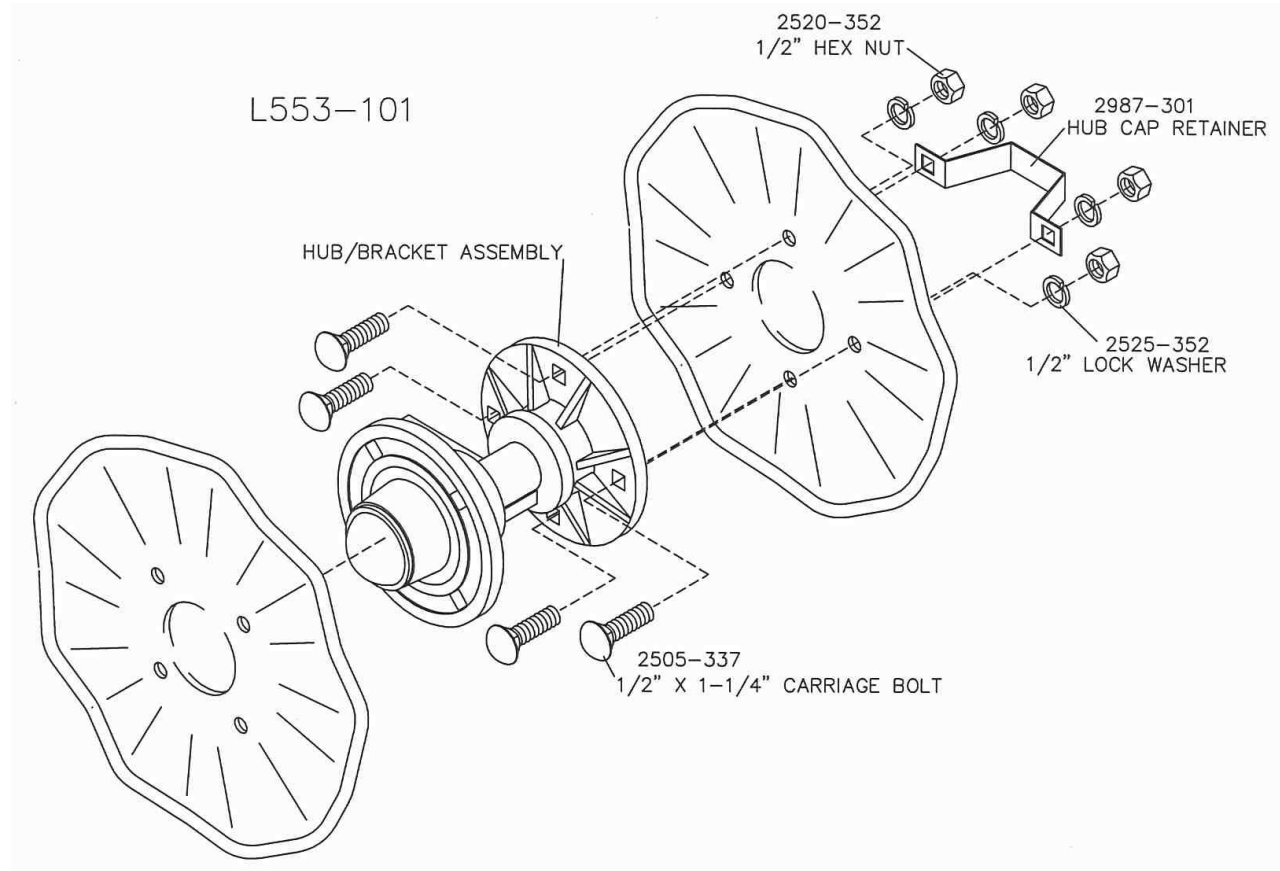

OPERATION

- The V.T.A.™ should be operated 6-10 mph.
- Level the toolbar frame so that the coultter blades are the same depth front to back and side to side.
- Operate the coultter blades at 3" +/-1" in the soil.
- If needed, add ballast or weight to maintain coultter blade depth.

1. Set/mount coultter blades to run perpendicular to the soil. Operation depth and blade wear can be affected if the shank is mounted crooked or if the toolbar is not level side to side.
2. **After a few hours of use, check all bolts for tightness and proper torque.**
3. After a day of use (10-12 hours) check coultter hubs for loose bearings. There should be no endplay in the hub bearings allowing the blade to wobble. If necessary, remove hubcap and cotter pin and adjust the slotted nut to remove wobble, recommended torque of 15 ft. lbs. and re-insert cotter pin. If the wobble or looseness cannot be corrected, the bearings, cups and seals will need to be replaced.

DO NOT USE WORN OR DAMAGED PARTS.

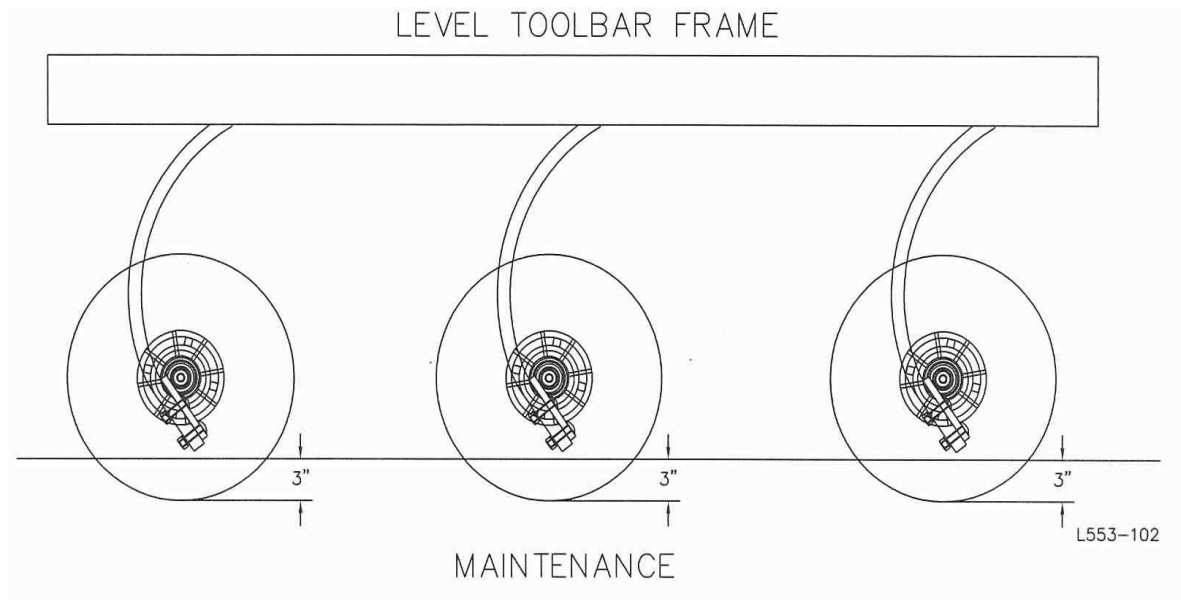

MAINTENANCE

LUBRICATION: USE #2 MULTI-PURPOSE LITHIUM GREASE

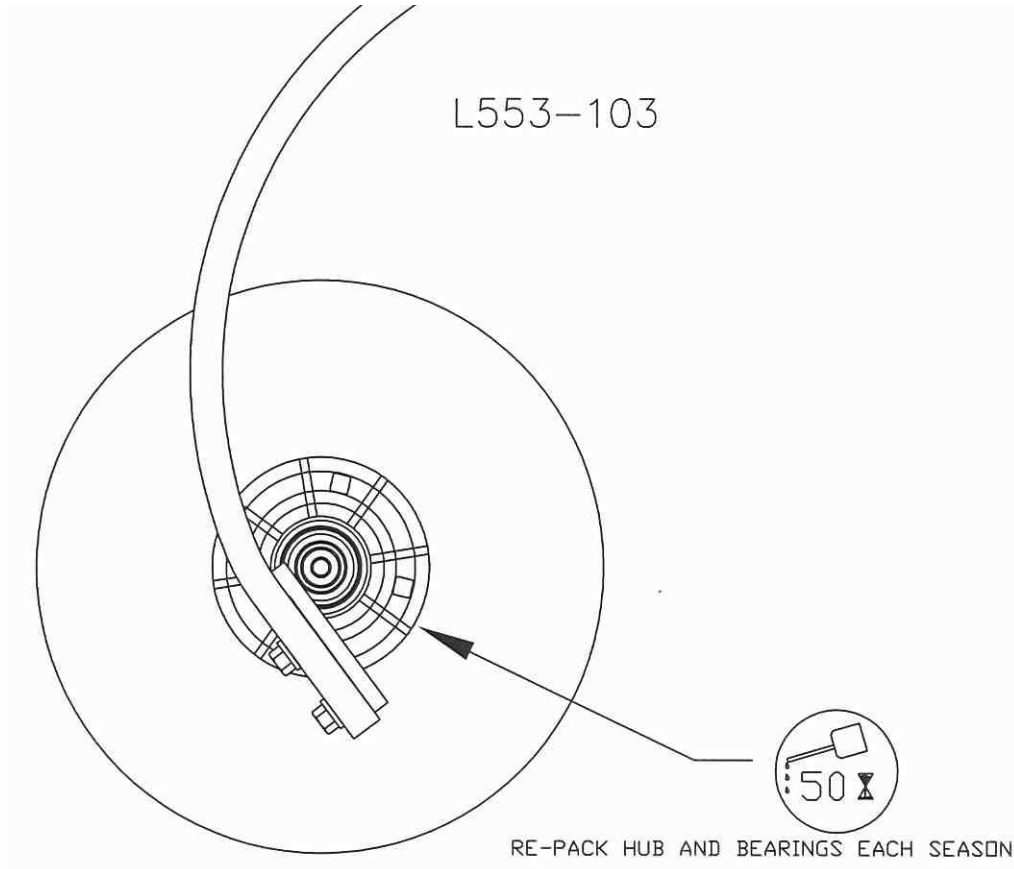

To ensure longevity and reliability of the V.T.A.™ Coulters, the recommended lubrication schedule should be followed using multi-purpose grease at hourly intervals as indicated.

BEARING ADJUSTMENT:

1. Raise the toolbar until the blade is clear of the ground. Place a safety stand under the toolbar. Remove the hubcap, cotter pin, slotted nut and washer from the hub assembly. Remove the blade from the hub assembly.
2. Remove bearing cones and seals from hub.
3. Wash the old grease from the hub, bearing cups, spindle spacers, seals and bearing cones. Inspect the condition of the bearing cups, cones and seals. Replace if necessary.
4. Apply #2 multi-purpose lithium grease on each bearing. Make sure the space around each roller is filled. Lubricate the bearing cups.
5. Position the bearing in the cup and install the seal. Lubricate the seal lips and proceed with re-assembly of the removed parts including the blade. Blade bolt torque is 90 to 96 ft. lbs.
6. Tighten the slotted nut to 15 ft. lbs. or until a definite drag is felt when the blade is turned by hand. Tighten the nut one-slot position to line up the cotter pin hole with a slot. Secure the nut with a new cotter pin, replace hubcap.

PARTS IDENTIFICATION

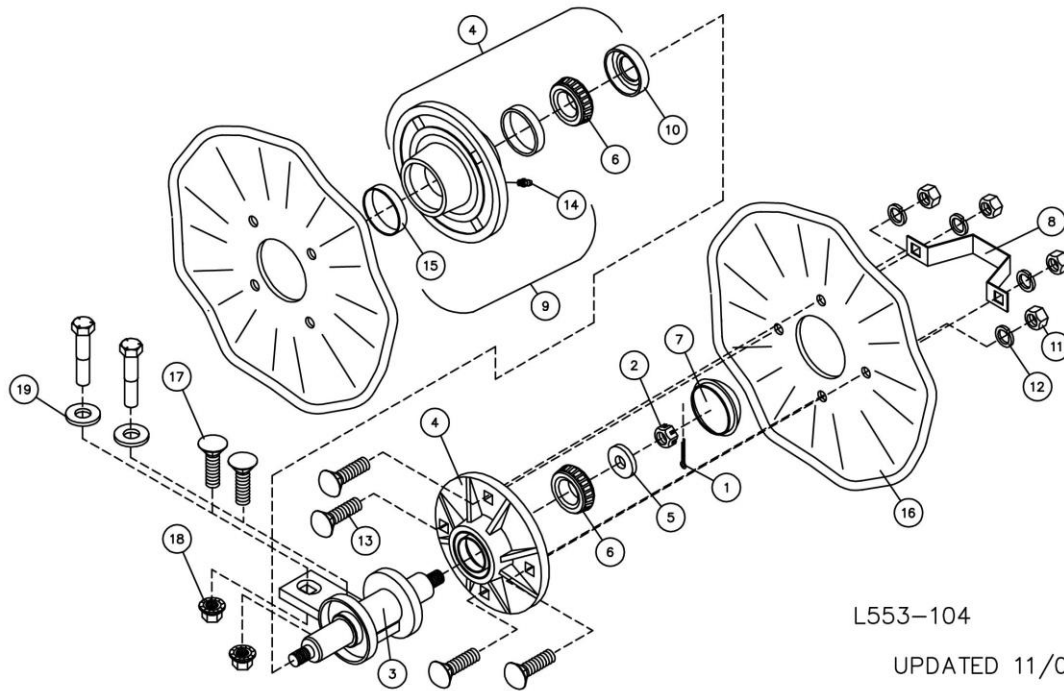

DET	QTY	PART NO.	DESCRIPTION
1	2	2531-102	1/8 X 1-1/4 COTTER PIN BLACK
2	2	2520-469	5/8-18 SLOTTED HEX NUT, BLACK
3	1	2982-200	V.T.A. SPINDLE W.A.
4	2	2900-102	HUB SUB-ASSEMBLY (INCLUDES #6, #9, #10)
5	2	2526-449	5/8 FLATWASHER, 1/4 +- .010 THK
6	4	2550-027	CONE, LM67048
7	2	2570-375	HUB CAP, WILTON #909902
8	2	2987-301	HUB CAP RETAINER
9	2	2900-105	HUB PRESSED ASSEMBLY (INCLUDES #14 & #15)
10	2	2550-066	TRIPLE LIP SEAL, NTI #1812-4
11	8	2520-352	1/2-13 HEX NUT ZYD.
12	8	2525-352	1/2 MED LOCK WASHER ZYD.
13	8	2505-337	1/2-13 X 1-1/4 CAR BLT GR 5 ZYD.
14	2	2533-110	1/4-28 ZERK, STRAIGHT SELF-TAP
15	4	2550-029	CUP, EWC #LM67010
16	2	2571-154	.157 X 17.6 X 1", 8 FLUTE
	2	2571-155	.157 X 17.656" 13 FLUTE BLADE
	2	2571-179	.157 X 17.63" 25 FLUTE BLADE
	2	2571-169	.25X18 STRAIGHT BLADE W/SQHOLE
	2	2571-168	.157 X 20" MULTI-HOLE FLUTTED
	2	2571-178	.25X20 STRAIGHT BLADE W/SQHOLES
	2	2571-201	.20 X 20 V-NOTCH BUBBLE BLADE
	2	2571-202	.157 X 19.94" 25 WAVE BLADE
	2	2571-196	.236 X 22" COULTER BLADE
17	2	2506-298	7/16-14X2 1/4 #3 PLOW BLT SPEC
	2	2506-307	1/2-13 X 2 1/2 #3 PLOW BLOT
	2	2502-296	1/2-13 X 2-1/2 HHCS GR5 ZP
18	2	2520-307	7/16-14 FLANGE WHZLOCK HEXNUT
	2	2520-361	1/2-13 FLANGE WHZLOCK HEXNUT
19	2	2526-355	1/2 FLAT WASHER HARD'ND ZYD

PARTS IDENTIFICATION

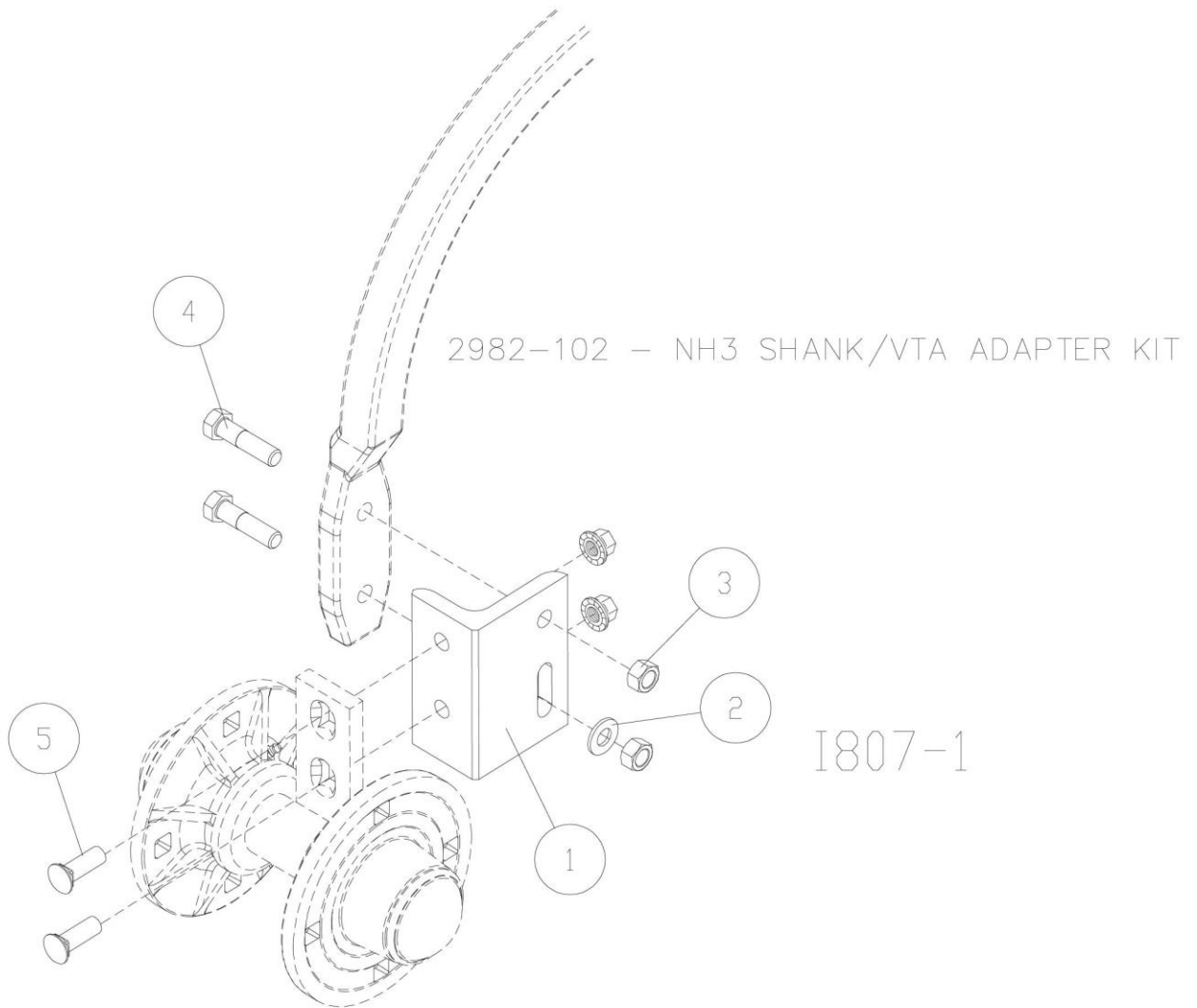

DET	QTY	PART NO.	DESCRIPTION
1	1	2982-305	VTA ADAPTER ANGLE
2	1	2526-355	1/2 FLAT WASHER HARDENED
3	2	2520-357	1/2-13 HEX LOCK NUT ZYD.
4	2	2502-317	1/2-13 X 1-3/4 HHCS GR 5 ZYD
5	2	2505-339	1/2-13 X 1-1/2 CAR BLT GR 5 ZYD

Our name Is getting known

Just a few years ago, Yetter products were sold primarily to the Midwest only. Then we embarked on a program of expansion and moved into the East, the South, the West and now north into Canada. We're even getting orders from as far away as Australia and Africa.

So, when you buy Yetter products . . .you're buying a name that's recognized. A name that's known and respected. A name that's become a part of American agriculture and has become synonymous with quality and satisfaction in the field of conservation tillage.

Thank you.

YETTER MANUFACTURING CO.
Colchester, IL 62326-0358 • 309/776-4111
Toll Free 800/447-5777
Fax 309/776-3222
Website: WWW.YETTERCO.COM
E-MAIL: INFO@YETTERCO.COM

2565-732_REV_D • 08/2024