



**ROW UNIT MID-MOUNT
FERTILIZER INJECTION OPENER
MODELS 2968-020A, 2968-021A SINGLE WHEEL
MODELS 2968-040, 2968-041 DUAL WHEEL
SET UP & PARTS MANUAL
2565-951_REV_B1 – 08/2024**



YETTER MANUFACTURING CO.
FOUNDED 1930

Colchester, IL 62326-0358
Toll free: 800/447-5777
309/776-3222 (Fax)
Website: www.yetterco.com
E-mail: info@yetterco.com

FOREWORD

You've just joined an exclusive but rapidly growing club.
For our part, we want to welcome you to the group and thank you for buying a Yetter product.

We hope your new Yetter products will help you achieve both goals-increase your productivity and increase your efficiency so that you may generate more profit.

This operator's manual has been designed into four major sections: Foreword, Safety Precautions, Installation Instructions and Parts Breakdown.

This **SAFETY ALERT SYMBOL** indicates important safety messages in the manual. When you see this symbol, be alert to the possibility of **PERSONAL INJURY** and carefully read the message that follows.

 **DANGER:** Indicates an imminently hazardous situation which, if not avoided "will" result in death or serious injury. This signal word is to be limited to the most extreme situations

 **WARNING:** Indicates a potentially hazardous situation which, if not avoided, "could" result in death or serious injury.

 **CAUTION:** Indicates a potentially hazardous situation, which if not avoided, "may" result in minor or moderate injury. It may also be used to alert against unsafe practices.

 **NOTICE:** Indicates information considered important, but not hazard related (e.g., messages relating to property damage).

It is the responsibility of the user to read the operator's manual and comply with the safe and correct operating procedure and to lubricate and maintain the product according to the maintenance schedule in the operator's manual.

The user is responsible for inspecting his machine and for having parts repaired or replaced when continued use of the product would cause damage or excessive wear to the other parts.

It is the user's responsibility to deliver his machine to the Yetter dealer who sold him the product for service or replacement of defective parts, which are covered by the warranty policy.

If you are unable to understand or follow the instructions provided in this publication, consult your local Yetter dealer or contact:

YETTER MANUFACTURING CO.

309/776-4111

800/447-5777

309/776-3222 (FAX)

Website: www.yetterco.com

E-mail: info@yetterco.com

WARRANTY

Yetter Manufacturing warrants all products manufactured and sold by it against defects in material. This warranty being expressly limited to replacement at the factory of such parts or products as shall appear to be defective after inspection. This warranty does not obligate the Company to bear cost of labor in replacement of parts. It is the policy of the Company to make improvements without incurring obligations to add them to any unit already sold. No warranty is made or authorized to be made, other than herein set forth. This warranty is in effect for one year after purchase.

DEALER: _____

Yetter Manufacturing warrants its own products only and cannot be responsible for damages to equipment on which mounted.

SAFETY PRECAUTIONS

A brief description of signal words that may be used in this manual:

DANGER: Indicates an imminently hazardous situation which, if not avoided “will” result in death or serious injury. This signal word is to be limited to the most extreme situations.

WARNING: Indicates a potentially hazardous situation which, if not avoided, “could” result in death or serious injury.

CAUTION: Indicates a potentially hazardous situation, which if not avoided, “may” result in minor or moderate injury. It may also be used to alert against unsafe practices.

NOTICE: Indicates information considered important, but not hazard related (e.g., messages relating to property damage).

Consult your implement and tractor operator’s manual for correct and safe operating practices. Be aware of towed implement width and allow safe clearance.

Safety decals are placed on the implement to alert the operator and others to the risk of personal injury or unsafe operation during normal operations and servicing.

1. The safety decals must be kept clean and in good condition to ensure that they are legible.
2. Safety decals must be replaced if they are missing or illegible.
3. When components are replaced during repair or servicing, check that the new components include the necessary safety signs.
4. Replacement safety decals may be obtained from your local dealer.

WARNING

Read these instructions carefully to acquaint yourself with the Equipment. Working with unfamiliar equipment can lead to accidents.

Never park the equipment on a steep incline or leave the equipment running unattended.

Never clean, lubricate or adjust a machine that is in motion.

Always check that straps are secure.

Make sure latches are in pinned position when moving equipment.

Do not allow children to operate this equipment.

Do not allow riders on the equipment, trailer and/or pick-up.

Use speed and caution dictated by the terrain being traversed. Do not operate on any slope steep enough to cause tipping or loss of control.

Read and understand the operator’s manual and require all other persons who will operate the equipment to do the same.

If operating on public roadways, where legal, be certain all lighting is operating properly and observe all traffic laws.

Beware of increased stopping distances and control effort when operating with implements attached.

Be familiar with all controls and be prepared to stop equipment quickly in an emergency.

FAILURE TO HEED MAY RESULT IN PERSONAL INJURY OR DEATH.

TABLE OF CONTENTS

FOREWORD.....	2
SAFETY.....	2-3
INSTALLATION.....	17-21
OPERATION.....	22
MAINTENANCE.....	25-30
ADJUSTMENTS.....	23
LIQUID FERTILIZER APP. RATE AND PRESSURE CHART.....	24
PARTS IDENTIFICATION.....	31-40

Pictorial Parts List 2968-020A



2968-140 QTY 1



2968-222 – QTY 1



2968-359-RH – QTY 1



2968-359-LH – QTY 1



2968-361 – QTY 2

Pictorial Parts List 2968-021A



2968-148 QTY 1



2968-223 QTY 1



2968-359-LH QTY 1



2968-359-RH QTY 1



2968-361 QTY 1

Pictorial Parts List 2968-040-LB



2968-145 QTY 1



2968-222 – QTY 1



2968-359-RH – QTY 1



2968-360 – QTY 1



2968-361 – QTY 2

Pictorial Parts List 2968-041-LB



2968-147 QTY 1



2968-223 QTY 1



2968-359-RH QTY 1

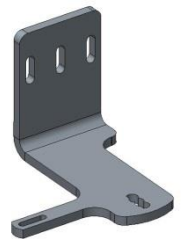

2968-360 QTY 1



2968-361 QTY 1

Pictorial Parts List 2968-132



2505-207 – QTY 4

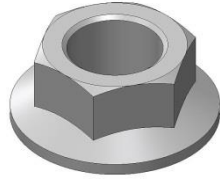

2520-206 – QTY 4

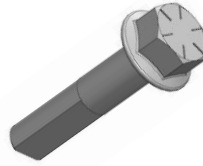

2570-740 – QTY 1



2965-128 – QTY 1



2965-352 – QTY 2



2968-320 – QTY 1

Pictorial Parts List 2968-133



2505-207 – QTY 4

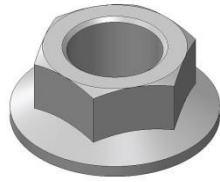

2520-206 – QTY 4

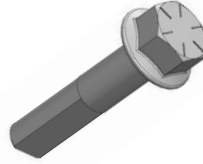

2570-740 – QTY 1



2965-128 – QTY 1



2965-352 – QTY 2



2968-364 – QTY 1

Pictorial Parts List 2968-140



← 2502-104 -1/4-20 X 1/2 HHCS GR. 5 ZYD.– QTY 2

2502-351 -1/2-13 X 2 HHCS GR.5 ZP– QTY 5 →



← 2502-379 -M12 X 1.75 X 35 GRD 10.9 ZYD– QTY 2

2515-846 -MALE CONNECTOR - 3/8 X 1/4 NPTF– QTY 1 →

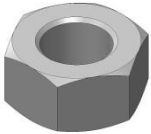
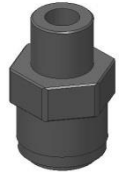

← 2520-151 -1/4-20 HEX NUT, GR 2, ZP– QTY 2

2520-253 -3/8-16 JAM HEX NUT, GR 2, ZP– QTY 2 →

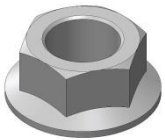
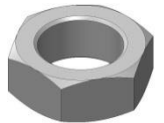

← 2520-361 -1/2-13FLANGE WHZLCK HXNT, GR 5, ZP – QTY 2

2520-464 -5/8-11 WHIZLOCK ZP, GR 8– QTY 1 →

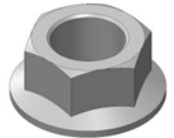

← 2525-151 - 1/4 MED. LOCKWASHER ZP – QTY 2

2525-251 -3/8 MED. LOCKWASHER ZP – QTY 1 →



← 2525-352 - 1/2 MED LOCKWASHER ZP – QTY 5



← 2526-253 - 3/8 SAE FLATWASHER ZP – QTY 2

Continued

Pictorial Parts List 2968-140



2526-454 - 5/8SAE FLATWASHER HRD'ND ZP – QTY 1



2570-724 - 3/8 HOSE P-CLIP W/ VINYL CUSHION – QTY 1



2968-218 - INJECTOR HOLDER W.A. – QTY 1



2968-363 - HOSE HOLDER, FORMED – QTY 1

Pictorial Parts List 2968-145



← 2502-104 -1/4-20 X 1/2 HHCS GR. 5 ZYD.– QTY 2

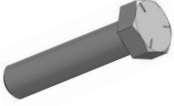

←2502-314 -1/2-13 X 2-1/4" GRADE 5 HHCS ZYD – QTY 3

2502-351 -1/2-13 X 2 HHCS GR.5 ZP– QTY 2

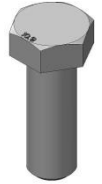

←2502-379 -M12 X 1.75 X 35 GRD 10.9 ZYD– QTY 2

2515-846 -MALE CONNECTOR - 3/8 X 1/4 NPTF– QTY 2

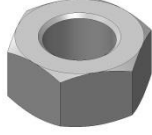
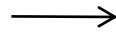

← 2520-151 -1/4-20 HEX NUT, GR 2, ZP– QTY 2

2520-253 -3/8-16 JAM HEX NUT, GR 2, ZP– QTY 4

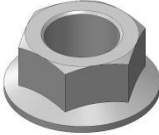
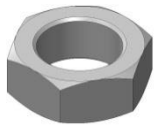

← 2520-361 -1/2-13FLANGE WHZLCK HXNT, GR 5, ZP – QTY 2

2520-464 -5/8-11 WHIZLOCK ZP, GR 8– QTY 2

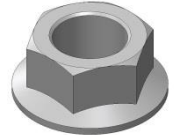
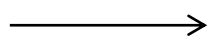

← 2525-151 - 1/4 MED. LOCKWASHER ZP – QTY 2

2525-251 -3/8 MED. LOCKWASHER ZP – QTY 2

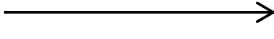

← 2525-352 - 1/2 MED LOCKWASHER ZP – QTY 5

Continued

Pictorial Parts List 2968-145



2526-253 - 3/8 SAE FLATWASHER ZP – QTY 4



2526-454 - 5/8SAE FLATWASHER HRD'ND ZP – QTY 3



2570-724 - 3/8 HOSE P-CLIP W/ VINYL CUSHION – QTY 2



2968-218 - INJECTOR HOLDER W.A. – QTY 2



2968-363 - HOSE HOLDER, FORMED – QTY 1

Pictorial Parts List 2968-147



← 2502-104 -1/4-20 X 1/2 HHCS GR. 5 ZYD.– QTY 2

2502-245 - 3/8-16 X 1-3/4 HHCS GR 5 ZP – QTY 1 →

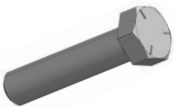

← 2502-314 -1/2-13 X 2-1/4" GRADE 5 HHCS ZYD – QTY 3



← 2502-362 -1/2-13 X 5 HHCS GR. 5 ZP – QTY 1

2502-368 -1/2-13 X 5-1/2 HHCS GR5 ZP – QTY 1 →



← 2502-372 -1/2-13 X 6-1/2 HHCS GR5 ZP – QTY 1

2515-846 -MALE CONNECTOR - 3/8 X 1/4 NPTF– QTY 2 →

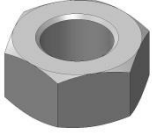

← 2520-151 -1/4-20 HEX NUT, GR 2, ZP– QTY 2

2520-253 3/8 JAM HEX NUT – QTY 4 →



2520-357 1/2-13 LOCK HEX NUT, GR A, ZP– QTY 2 →



2520-464 5/8 WHIZ LOCK– QTY 2 →

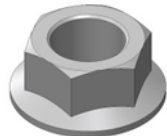

2525-251 -3/8 MED. LOCKWASHER ZP – QTY 2 →



← 2525-352 - 1/2 MED LOCKWASHER ZP – QTY 3

Pictorial Parts List 2968-147



2526-253 - 3/8 SAE FLATWASHER ZP – QTY 8



2526-352 - 1/2 SAE FLATWASHER ZP – QTY 4



2526-454 - 5/8SAE FLATWASHER HRD'ND ZP – QTY 2



2570-724 - 3/8 HOSE P-CLIP W/ VINYL CUSHION – QTY 2



2968-218 - INJECTOR HOLDER W.A. – QTY 2



2968-363 - HOSE HOLDER, FORMED – QTY 1



NO PHOTO

2968-370 – GAUGE WHEEL ARM STOP – QTY 1



NO PHOTO

6000-523 – ECCENTRIC BUSHING CLOSE WHEEL– QTY 2

Pictorial Parts List 2968-148



← 2502-104 -1/4-20 X 1/2 HHCS GR. 5 ZYD.– QTY 2

2502-245 - 3/8-16 X 1-3/4 HHCS GR 5 ZP – QTY 1 →

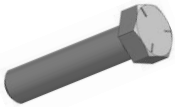

← 2502-351 -1/2-13 X 2" GRADE 5 HHCS – QTY 3



← 2502-362 -1/2-13 X 5 HHCS GR. 5 ZP – QTY 1

2502-368 -1/2-13 X 5-1/2 HHCS GR5 ZP – QTY 1 →



← 2502-372 -1/2-13 X 6-1/2 HHCS GR5 ZP – QTY 1

2515-846 -MALE CONNECTOR - 3/8 X 1/4 NPTF– QTY 2 →

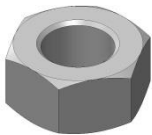

← 2520-151 -1/4-20 HEX NUT, GR 2, ZP– QTY 2

2520-253 3/8 JAM HEX NUT – QTY 2 →



2520-357 1/2-13 LOCK HEX NUT, GR A, ZP– QTY 2 →



2520-464 5/8 WHIZ LOCK– QTY 1 →

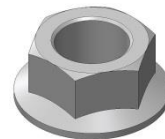

2525-251 -3/8 MED. LOCKWASHER ZP – QTY 2 →



← 2525-352 - 1/2 MED LOCKWASHER ZP – QTY 3

Pictorial Parts List 2968-148



2526-253 - 3/8 SAE FLATWASHER ZP – QTY 5



2526-352 - 1/2 SAE FLATWASHER ZP – QTY 4



2526-454 - 5/8SAE FLATWASHER HRD'ND ZP – QTY 2



2570-724 - 3/8 HOSE P-CLIP W/ VINYL CUSHION – QTY 2



2968-218 - INJECTOR HOLDER W.A. – QTY 2



2968-363 - HOSE HOLDER, FORMED – QTY 1



NO PHOTO

2968-370 – GAUGE WHEEL ARM STOP – QTY 1



NO PHOTO

6000-523 – ECCENTRIC BUSHING CLOSE WHEEL– QTY 2

INSTALLATION

BOLT TORQUE

Mounting bolts and hardware

Before operating the Titan™ Residue Manager for the first time, check to be sure that all hardware is tight. Check all hardware again after approximately 50 hours of operation and at the beginning of each planting season.

All hardware used on the Titan™ Residue Manager is Grade 5 unless otherwise noted. Grade 5 cap screws are marked with three radial lines on the head. If hardware must be replaced, be sure to replace it with hardware of equal size, strength and thread type. Refer to the torque values chart when tightening hardware.







NOTICE: Over tightening hardware can cause as much damage as when under tightening. Tightening hardware beyond the recommended range can reduce its shock load capacity.

The chart below is a guide for proper torque. Use it unless a specified torque is called out elsewhere in the manual.

Torque is the force you apply to the wrench handle or the cheater bar, times the length of the handle or bar.

Use a torque wrench whenever possible.

The following table shows torque in ft. lbs. for coarse thread hardware.

BOLT DIA. AND THREADS PER INCH	 GRADE 2	 OR  GRADE 5 A-325	 GRADE 8
1/4	6	10	14
5/16	12	20	30
3/8 - 16	25	35	50
7/16 - 14	35	55	80
1/2 - 13	55	85	125
9/16 - 12	75	125	175
5/8 - 11	105	170	235
3/4 - 10	185	305	425
7/8 - 9	170	445	690
1-8	260	670	1030
1 1/8 - 7	365	900	1460
1 1/4 - 7	515	1275	2060
1 3/8 - 6	675	1675	2700
1 1/2 - 6	900	2150	3500
1 3/4 - 5	1410	3500	5600

Lubricate all bearings and moving parts as assembled and make certain that they work freely.



WARNING: Never work around the toolbar/implement while in a raised position without using safety lockups.



CAUTION: The Residue manager attachments are very heavy. Pay extra attention to lifting techniques while handling and or maneuvering the opener during assembly. Failure to do so may lead to personal injury.

INSTALLATION

1. Remove the v-closing wheels, arm and support bracket from the row unit.
2. Install the Fertilizer Wheel Mounting plate.
3. Attach the v-closing wheels, arm and support to the Fertilizer Wheel Mounting plate.
4. Attach the L-mount bracket to the wheel mounting plate.
5. Assemble the Fertilizer Wheel by inserting threaded end of 'D' bolt through 'D' hole in Fertilizer Wheel Mount Arm and secure with 5/8" lock washer and nut.
6. Assemble 2968-218 injector holder, hose coupler and nozzle tip (not supplied).
Injector tips can be ordered through fertilizer equipment dealer.
Calibrate the fertilizer pump and tips to maximum recommended pressure of 30 p.s.i. and minimum 20 p.s.i.

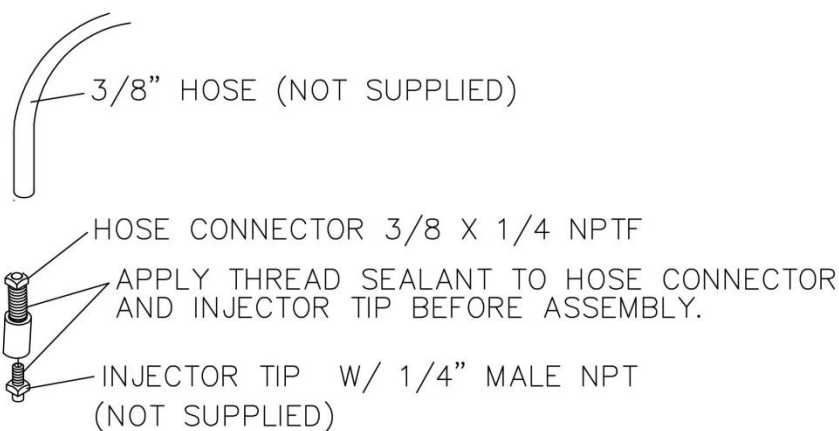

ISO-2968-020A-INJECTOR PLUMBING

7. Thread on 3/8" nut onto 2968-218 Injector Holder and insert the stud through hole of Arm. Install another 3/8" nut onto stud and adjust the nozzle to be directly behind the Fertilizer Wheel. Tighten nuts securely.
8. Plumb your fertilizer lines to the attachment. **Check that hoses do not become pinched as the planter unit and v-close arm bracket moves up and down.**



NOTICE: It is best to consult the fertilizer supplier for optimum placement when placing starter fertilizer in close proximity to the seed.



NOTICE: If there is a buildup of damp soil the planter gauge wheels or opener disks, then conditions are less than "ideal" and some problems may also be encountered with Fertilizer Injection Wheel. In some situations it may be advisable to remove the Fertilizer Injection Wheel from the planter unit, if the problem continues.

INSTALLATION

2968-020A FERTILIZER

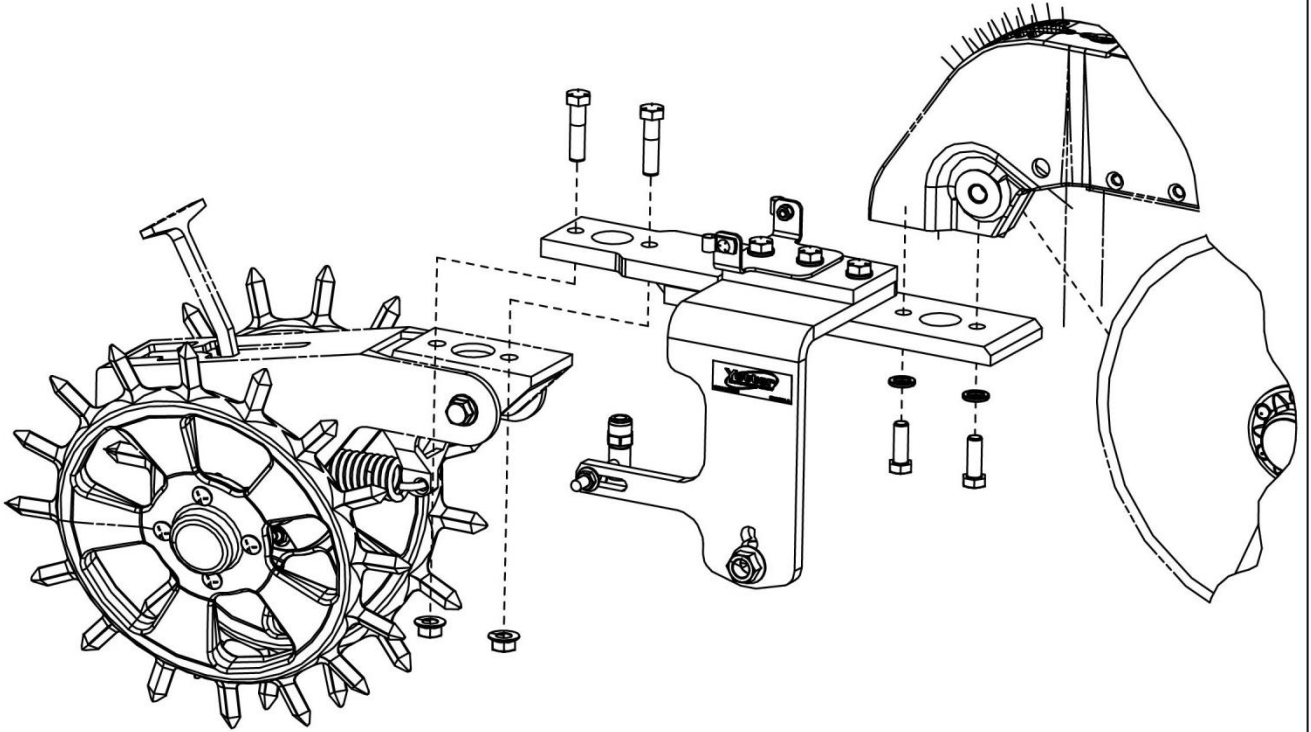

INSTALLATION

2968-020A FERTILIZER

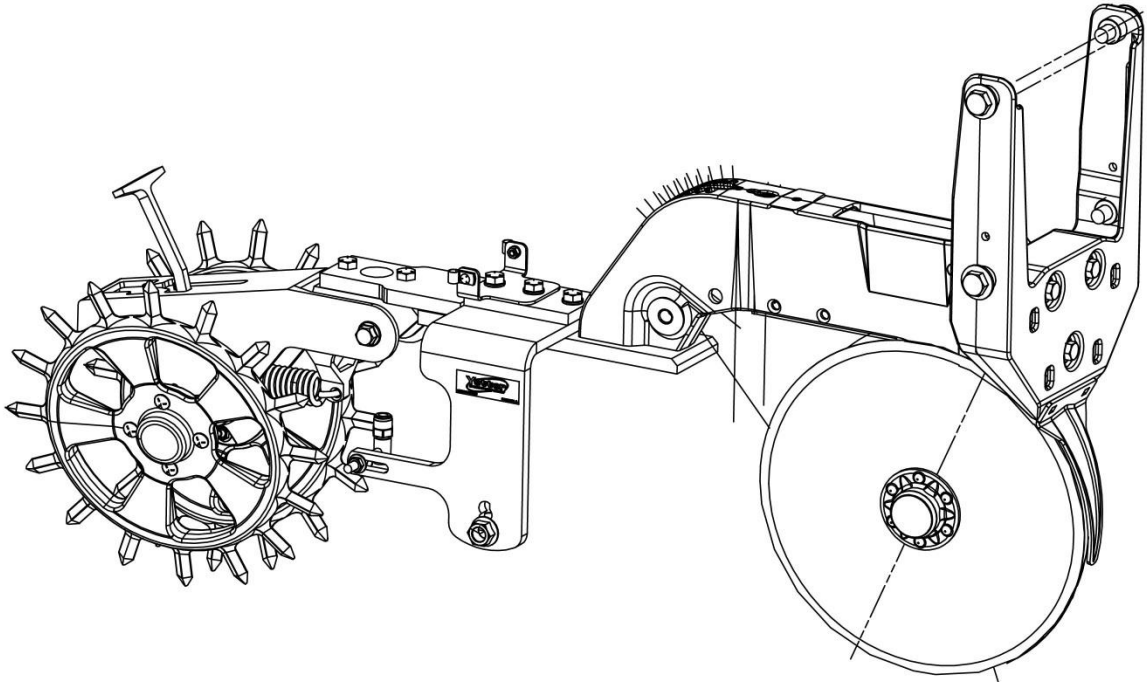

INSTALLATION

2968-020A FERTILIZER

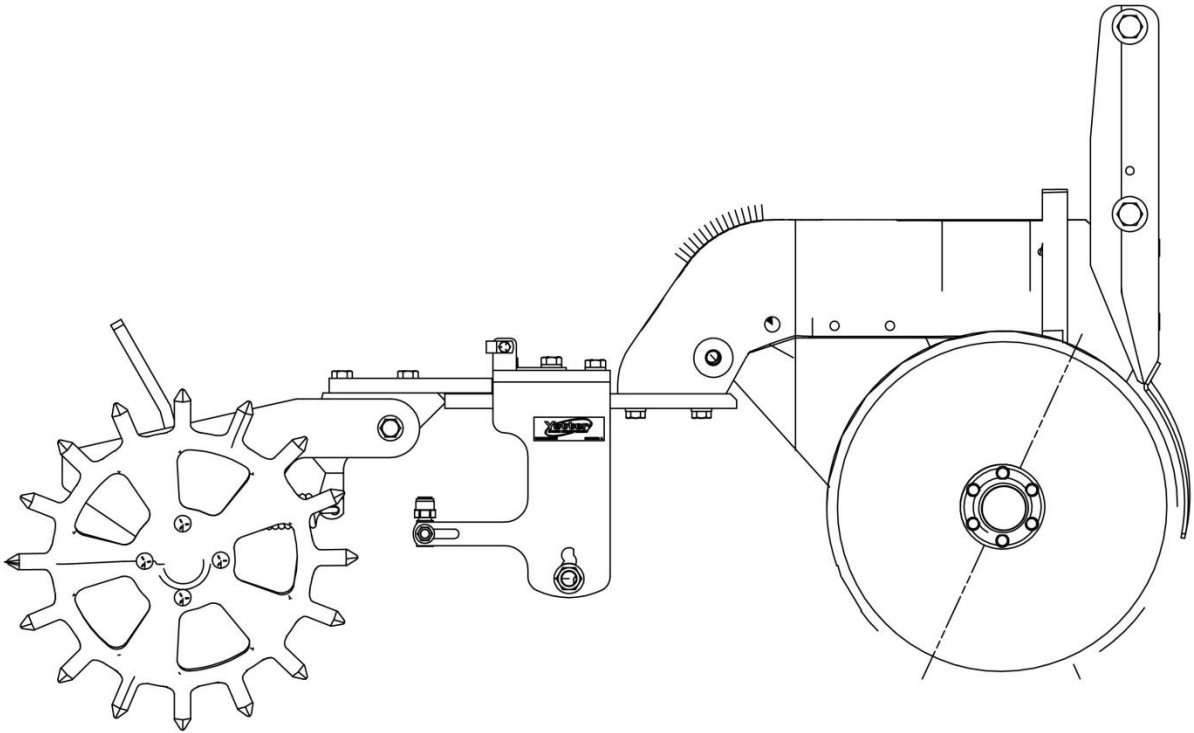

OPERATION

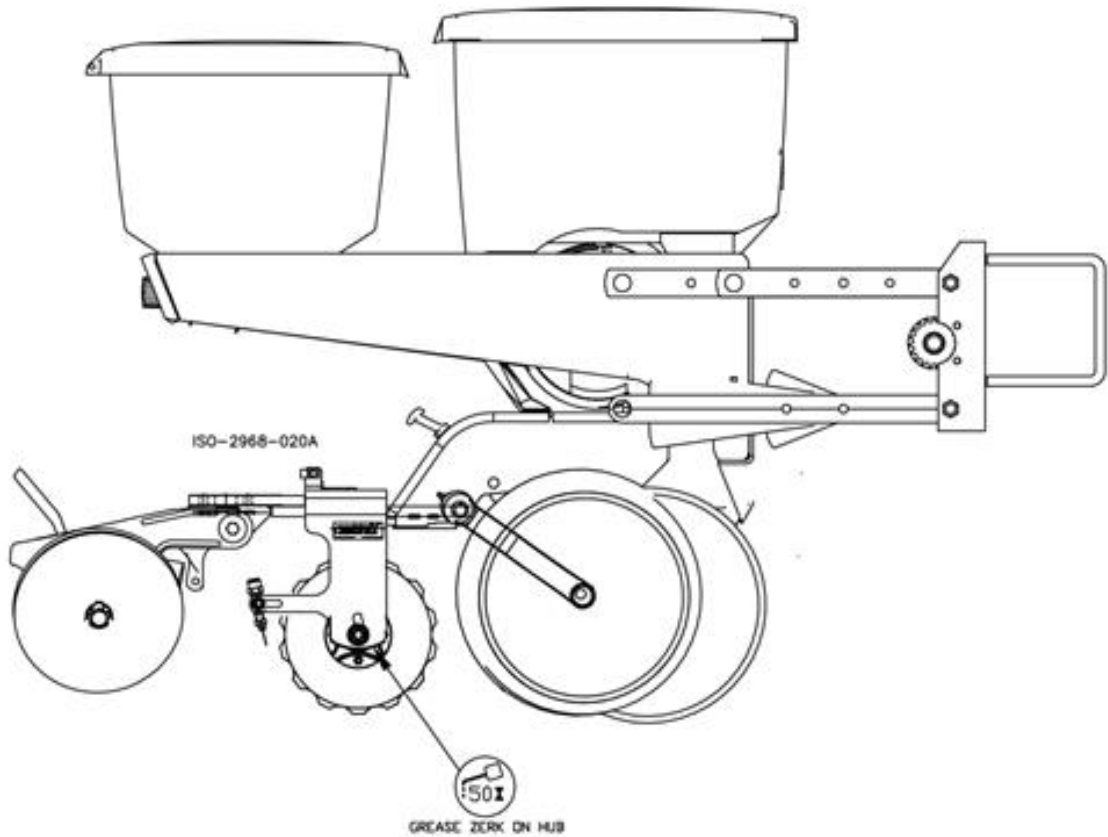

NOTICE: For proper operation, the planter frame must operate level (for, aft and side to side) and at the correct height, typically 20"-22".

ADJUSTMENTS

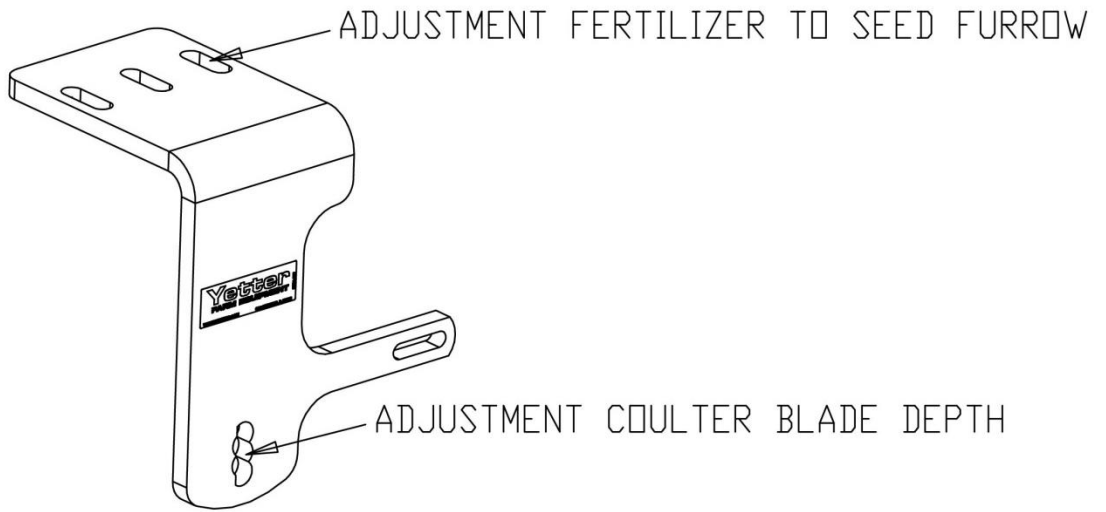

ISD-2968-020A-FERTILIZER PLACEMENT

LIQUID FERTILIZER APPLICATION RATE AND PRESSURE CHART

TABLES ARE BASED ON 30" NOZZLE SPACING

TIP #	LIQUID PRESSURE IN PSI	CAPACITY 1 NOZZLE IN GPM	GALLONS PER ACRE (USING WATER)					
			4 MPH H2O	5 MPH H2O	5.5 MPH H2O	6 MPH H2O	7 MPH H2O	8 MPH H2O
#00015	20	0.11	5.45	4.36	3.96	3.63	3.11	2.72
	25	0.12	5.94	4.75	4.32	3.96	3.39	2.97
	30	0.13	6.44	5.15	4.68	4.29	3.68	3.22
	40	0.15	7.43	5.94	5.40	4.95	4.24	3.71
	50	0.17	8.42	6.73	6.12	5.61	4.81	4.21
	60	0.18	8.91	7.13	6.48	5.94	5.09	4.46
#0002	20	0.14	6.93	5.54	5.04	4.62	3.96	3.47
	25	0.16	7.92	6.34	5.76	5.28	4.53	3.96
	30	0.17	8.42	6.73	6.12	5.61	4.81	4.21
	40	0.20	9.90	7.92	7.20	6.60	5.66	4.95
	50	0.23	11.39	9.11	8.28	7.59	6.51	5.69
	60	0.25	12.38	9.90	9.00	8.25	7.07	6.19
#0003	20	0.21	10.40	8.32	7.56	6.93	5.94	5.20
	25	0.24	11.88	9.50	8.64	7.92	6.79	5.94
	30	0.26	12.87	10.30	9.36	8.58	7.35	6.44
	40	0.30	14.85	11.88	10.80	9.90	8.49	7.43
	50	0.34	16.83	13.46	12.24	11.22	9.62	8.42
	60	0.37	18.32	14.65	13.32	12.21	10.47	9.16
#0004	20	0.28	13.86	11.09	10.08	9.24	7.92	6.93
	25	0.32	15.84	12.67	11.52	10.56	9.05	7.92
	30	0.35	17.33	13.86	12.60	11.55	9.90	8.66
	40	0.40	19.80	15.84	14.40	13.20	11.31	9.90
	50	0.45	22.28	17.82	16.20	14.85	12.73	11.14
	60	0.49	24.26	19.40	17.64	16.17	13.86	12.13
#0005	20	0.35	17.33	13.86	12.60	11.55	9.90	8.66
	25	0.40	19.80	15.84	14.40	13.20	11.31	9.90
	30	0.43	21.29	17.03	15.48	14.19	12.16	10.64
	40	0.50	24.75	19.80	18.00	16.50	14.14	12.38
	50	0.56	27.72	22.18	20.16	18.48	15.84	13.86
	60	0.61	30.20	24.16	21.96	20.13	17.25	15.10
#0006	20	0.42	20.79	16.63	15.12	13.86	11.88	10.40
	25	0.47	23.27	18.61	16.92	15.51	13.29	11.63
	30	0.52	25.74	20.59	18.72	17.16	14.71	12.87
	40	0.60	29.70	23.76	21.60	19.80	16.97	14.85
	50	0.67	33.17	26.53	24.12	22.11	18.95	16.58
	60	0.74	36.63	29.30	26.64	24.42	20.93	18.32
#0008	20	0.57	28.22	22.57	20.52	18.81	16.12	14.11
	25	0.63	31.19	24.95	22.68	20.79	17.82	15.59
	30	0.69	34.16	27.32	24.84	22.77	19.52	17.08
	40	0.80	39.60	31.68	28.80	26.40	22.63	19.80
	50	0.89	44.06	35.24	32.04	29.37	25.17	22.03
	60	0.98	48.51	38.81	35.28	32.34	27.72	24.26
#0010	20	0.71	35.15	28.12	25.56	23.43	20.08	17.57
	25	0.79	39.11	31.28	28.44	26.07	22.35	19.55
	30	0.87	43.07	34.45	31.32	28.71	24.61	21.53
	40	1.00	49.50	39.60	36.00	33.00	28.29	24.75
	50	1.12	55.44	44.35	40.32	36.96	31.68	27.72
	60	1.23	60.89	48.71	44.28	40.59	34.79	30.44
#0015	20	1.06	52.47	41.98	38.16	34.98	29.98	26.24
	25	1.19	58.91	47.12	42.84	39.27	33.66	29.45
	30	1.30	64.35	51.48	46.80	42.90	36.77	32.18
	40	1.50	74.25	59.40	54.00	49.50	42.43	37.13
	50	1.68	83.16	66.53	60.48	55.44	47.52	41.58
	60	1.81	89.60	71.68	65.16	59.73	51.20	44.80
ROW SPACING MULTIPLIER		10" X 3.3	15" X 2.0	18" X 1.66	20" X 1.5	36" X .83	38" X .79	40" X .75

Values in this chart area based on using water. To calculate nozzle size required for your fertilizer application, the weight of the fertilizer solution must be accounted for by using a conversion factor for specific gravity. The Conversion factor for 28% liquid nitrogen is 1.13. Example: desired rate of application is 10 GPA of 28% N multiply 10 gallons per acre of fertilizer you want to apply x the conversion factor for 28% N (1.13) to get an equivalent rate for water. 10 x 1.13 refers to the chart for 11.13 gallons per acre at your desired speed/MPH.

$$\text{GPA (Per Nozzle)} = \frac{5940 \times \text{GPM}}{\text{MPH} \times \text{W}}$$

$$\begin{aligned} \text{H2O} &= \text{WATER} \\ \text{GPA} &= \text{GALLON PER ACRE} \\ \text{GPM} &= \text{GALLON PER MINUTES} \\ \text{MPH} &= \text{MILES PER HOUR} \\ \text{W} &= \text{WIDTH} \end{aligned}$$

$$\begin{aligned} \text{SOLUTION} \\ 28\% &= \text{H2O}/1.13 \\ 32\% &= \text{H2O}/1.15 \end{aligned}$$

This table is a reference only. Please calibrate your equipment to insure proper rate of application.

The information contained in this issue is offered in good faith by Yetter Mfg. Co. to further the understanding of liquid fertilizer application.

However, the use of the information provided is beyond the control of Yetter Mfg. Co. and in no case shall Yetter Mfg. Co. or any seller of its products be responsible for any damages that may occur from the use of this information.

MAINTENANCE

Regularly inspect the residue manager for loose or worn parts. Repair and replace as needed.

BEARING ASSEMBLY AND LUBRICATION

Practice Safety

Understand and practice safe service procedures before doing work. Follow ALL the operating, maintenance and safety information in the equipment operator manual. Clear the area of bystanders, especially small children, when performing any maintenance or adjustments. Keep work area clean and dry. Use adequate lighting for the job. Use only tools, jacks and hoists of sufficient capacity for the job.

Never lubricate, service, or adjust machine while it is moving. Keep hands, feet, and clothing from power-driven moving and rotating parts. Disengage all power and operate controls to relieve pressure. Lower equipment to the ground and stop the engine. Remove the key. Wait for all moving parts to stop before servicing, adjusting, repairing or unplugging.

Securely support any machine elements with blocks or safety stands that must be raised for service work.

Keep all parts in good condition and properly installed. Fix damaged equipment immediately.

Replace worn or broken parts. Remove any buildup of grease, oil, or debris.

Make sure all guards are in place and properly secured when maintenance work is completed.

Assembly

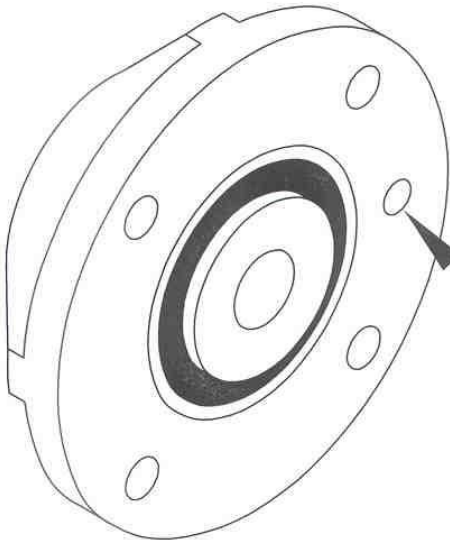

ALIGN GREASE
FITTING HOLES.

I190-1

MAINTENANCE

ALIGN THE HUB CAP GROOVE,
WITH THE WHEEL SLOT AND
GREASE FITTING

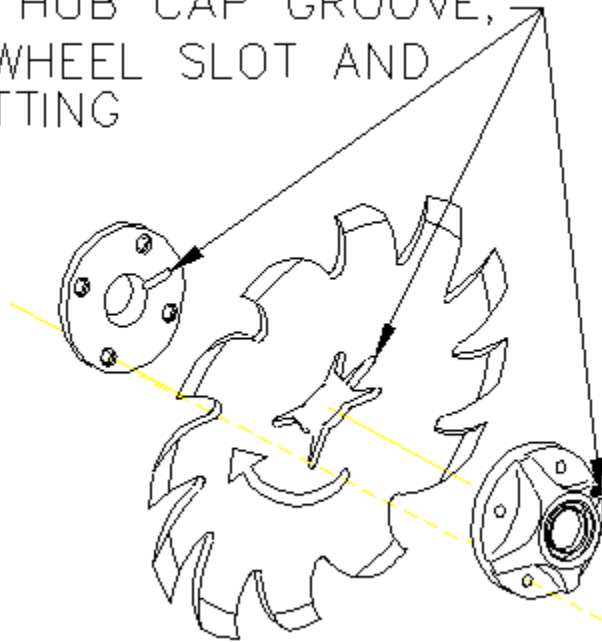

Be certain to align the grease fitting with the slot in the wheel and the hubcap so that the grease can flow freely.

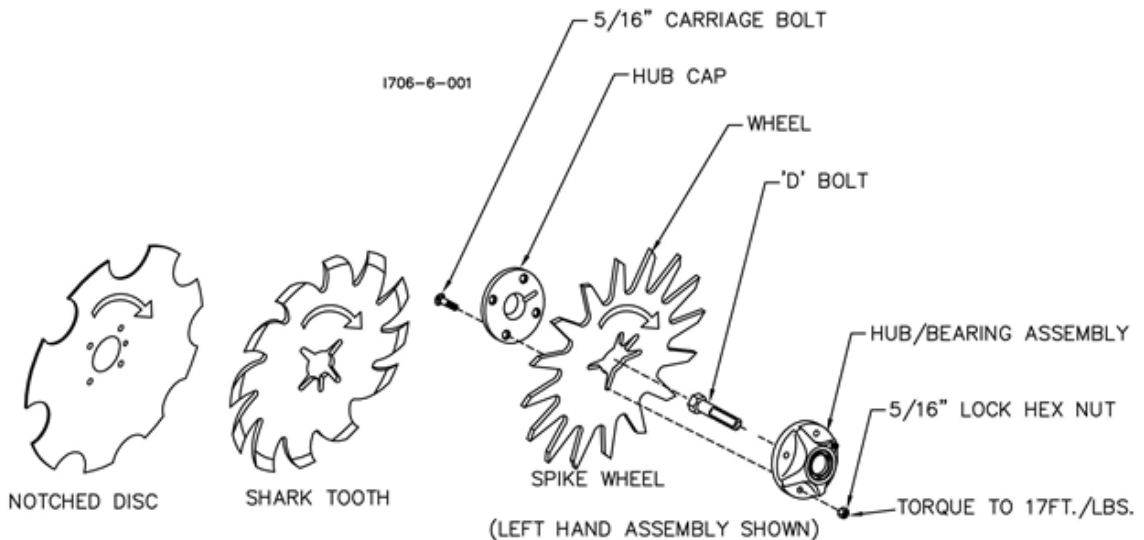

MAINTENANCE

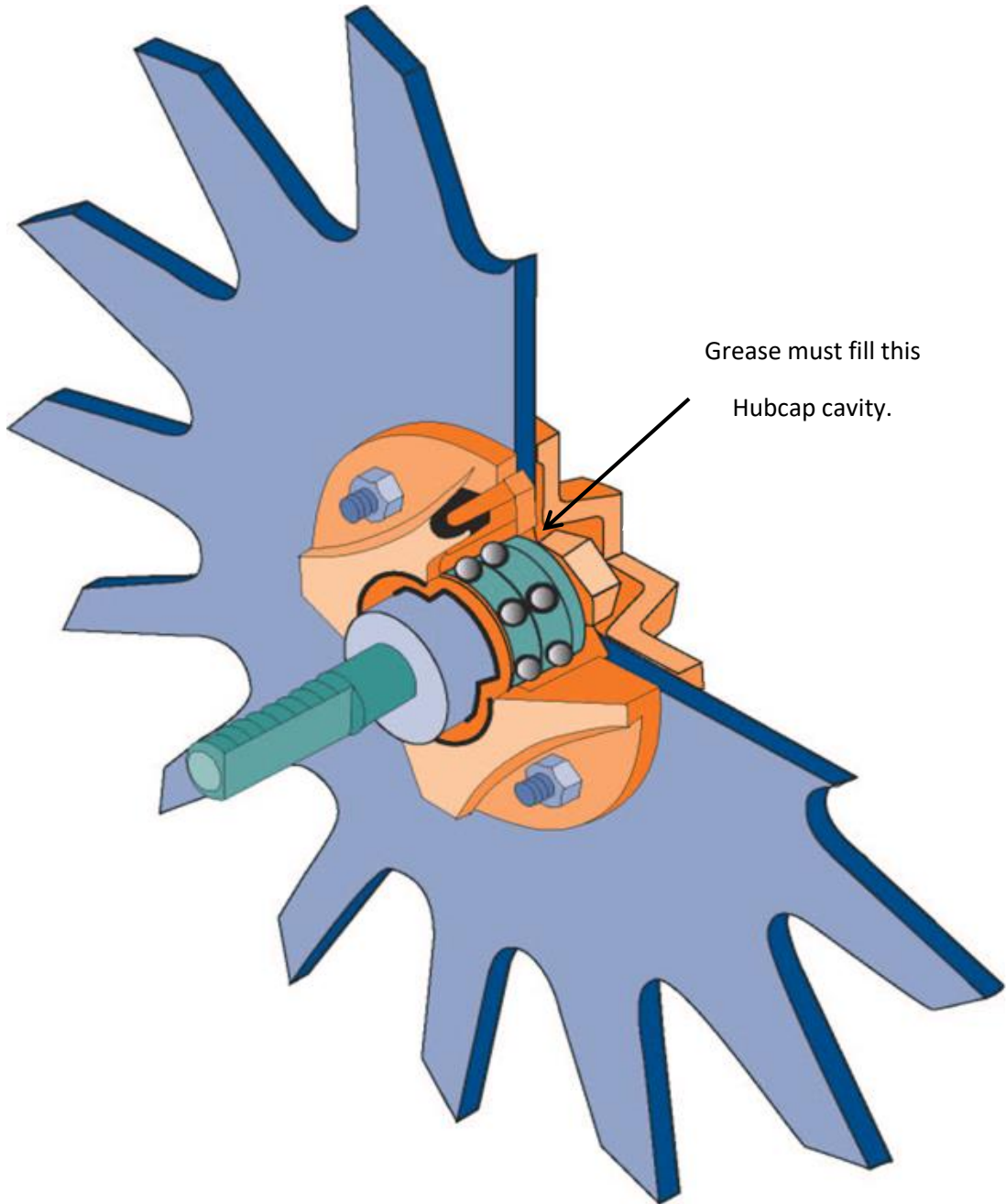

MAINTENANCE

Lubrication

 **CAUTION:** To help prevent serious injury or death to you or others caused by unexpected movement, service machine on a level surface. Lower machine to ground or sufficiently lock or block raised machine before servicing. If machine is connected to tractor, engage parking brake and place transmission in "PARK", shut off engine and remove key. If machine is detached from tractor, block wheels and use shop stands to prevent movement.

 **CAUTION:** Do not clean, lubricate, or adjust machine while in motion.

Use grease based on NLGI consistency numbers and the expected air temperature range during the service interval.

Use a **multi-purpose polyurea, water resistant, moderate speed, and NLGI grade #2** grease. Other greases may be used if they meet the following **NLGI Performance**

IMPORTANT: Some types of grease thickener are not compatible with others. Consult your grease supplier before mixing different types of grease.

Alternative Lubricants

Conditions in certain geographical areas may require special lubricants and lubrication practices which do not appear in the operator's manual. If there are any questions, consult Yetter Manufacturing Co. to obtain latest information and recommendation.

PART #	DESCRIPTION	OUNCES OF GREASE
2968-320	10" FERTILIZER WHEEL	1.12 OZ

Storing Lubricants

Your machine can operate at top efficiency only if clean lubricants are used.

Use clean containers to handle all lubricants.

Store them in an area protected from dust, moisture and other contaminants

MAINTENANCE

Lubrication Symbols

 Lubricate with grease at hourly interval indicated on symbol.

Lubrication Intervals

2968-020A-LUBRICATION

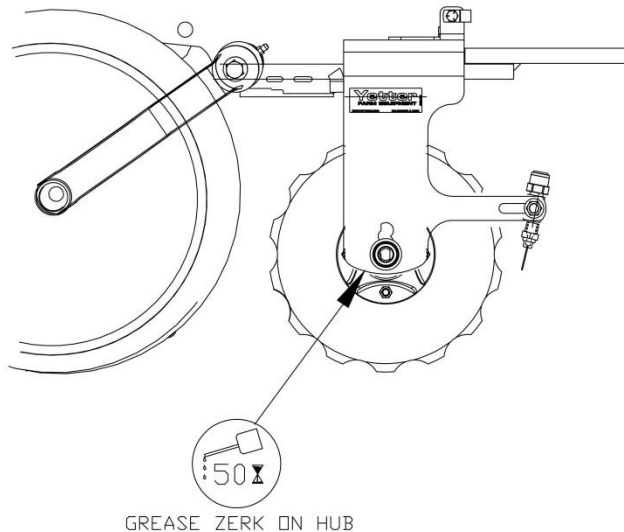

The recommended service intervals are based on normal conditions; severe or unusual conditions may require more frequent lubrication.

Perform each lubrication and service procedure at the beginning and end of each season. Clean grease fittings before using grease gun, to avoid injecting dirt and grit into the bearing. Replace any lost or broken fittings immediately. If a fitting fails to take grease, remove and clean thoroughly, replace fitting if necessary. Also check for failure of adjoining parts.

BEARING REPLACEMENT INSTALLATION

1. When assembling the spoke wheels, bearing assembly and hubcap, be sure to align the grease transfer hole in the spoke wheel with the groove in the hubcap and hole in the hub to allow grease passage.
2. Assemble the wheels, hubs and caps.
3. Grease the wheel/hub/bearing assembly.

MAINTENANCE

Storing the Equipment

Store the machine in an area away from human activity

Store machine in RAISED position.

Install service locks on all wheel cylinders.

At the end of the season, the machine should be thoroughly inspected and prepared for storage.

Repair or replace any worn or damaged components to prevent down time at the start of the next season. Store machine under cover with all parts in operating condition.

- Clean machine thoroughly to remove all dirt, debris and crop residue, which would hold moisture and cause rusting.
- Inspect machine for worn or broken parts. See your Yetter Farm Equipment dealer during the off-season so that parts or service can be acquired when machine is not needed in the field.
- Lubricate bearings as outlined in the Lubrication section
- Paint all parts which are chipped or worn and require repainting.
- Store machine in a clean, dry place with the planting unit out of the sun.
- If the machine cannot be stored inside, cover with a waterproof tarpaulin and tie securely in place.
- Do not allow children to play on or around the machine

PARTS IDENTIFICATION

2968-020A-L-LB

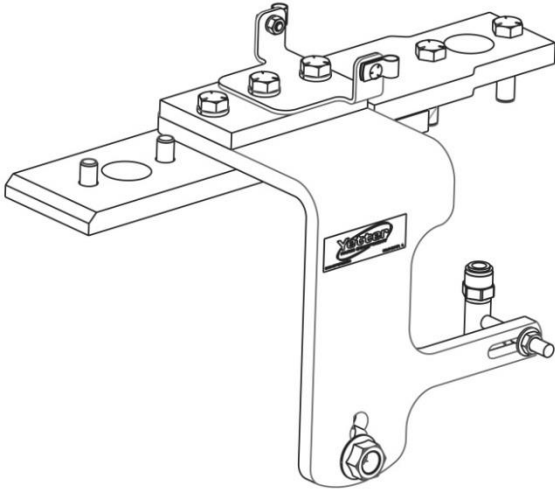

ITEM	PART NO.	DESCRIPTION	QTY
1	2502-104	1/4-20 X 1/2 HHCS GR. 5 ZYD.	2
2	2502-351	1/2-13 X 2 HHCS GR.5 ZP	5
3	2502-379	M12 X 1.75 X 35 GRD 10.9 ZYD	2
4	2515-846	MALE CONNECTOR - 3/8 X 1/4 NPTF	1
5	2520-151	1/4-20 HEX NUT ZP	2
6	2520-253	3/8-16 JAM HEX NUT ZP	2
7	2520-361	1/2-13 FLANGE WHZLCK HXNT, GR 5, ZP	2
8	2520-464	5/8-11 WHIZLOCK HEX NUT, GR 2, ZP	1
9	2525-151	1/4 MED. LOCKWASHER ZP.	2
10	2525-251	3/8 MED. LOCKWASHER ZP.	1
11	2525-352	1/2 MED LOCKWASHER ZP.	5
12	2526-253	3/8 SAE FLATWASHER ZP	2
13	2526-454	5/8 SAE FLATWASHER HRD'ND ZP	1
14	2570-724	3/8 HOSE P-CLIP W/ VINYL CUSHION	2
15	2968-218	INJECTOR HOLDER W.A.	1
16	2968-222	W.A. CLOSE WHEEL MOUNT, DUAL FERT	1
17	2968-361	ARM CLAMP	1
18	2968-363	HOSE HOLDER, FORMED	1
19	2968-359-LH	SHORT FERT. WHEEL MOUNT, LH	1

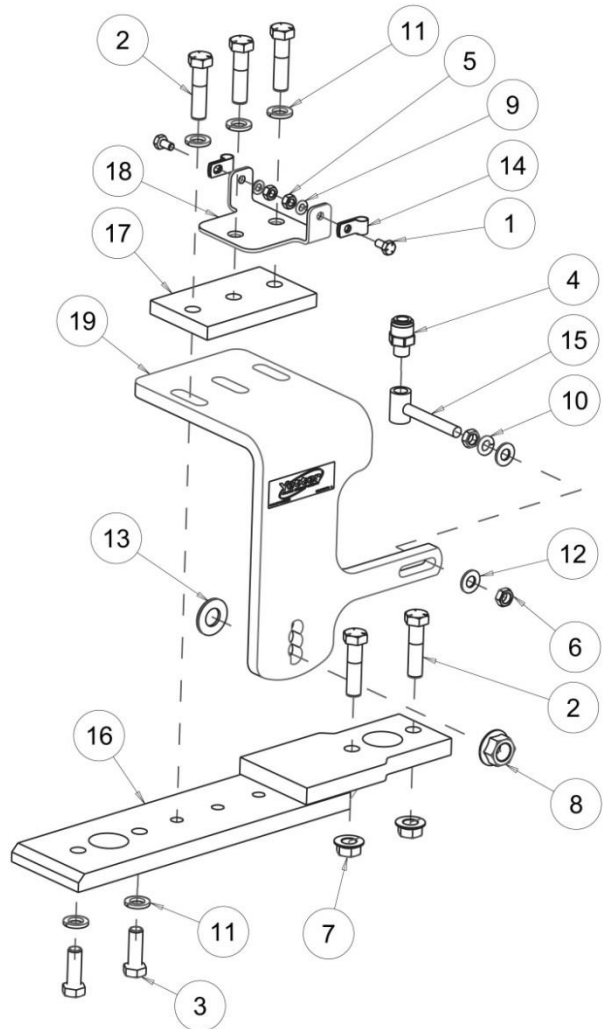

PARTS IDENTIFICATION

2968-020A-R-LB

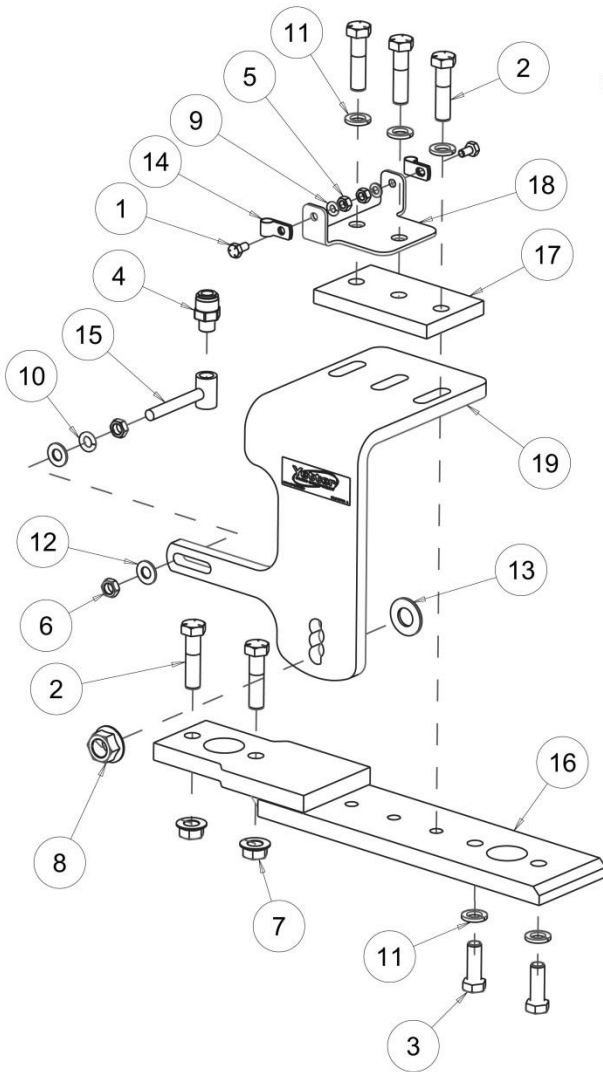
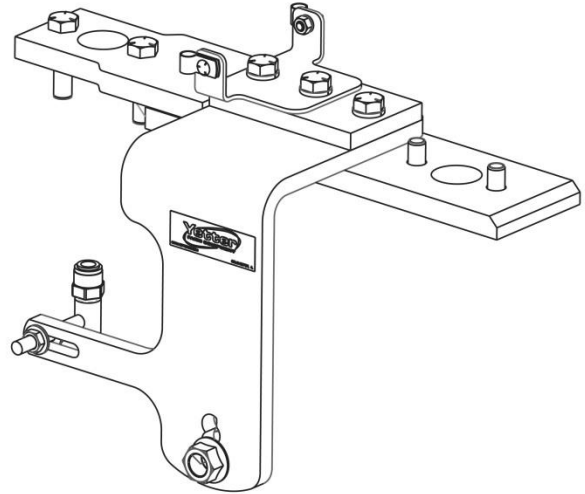

ITEM	PART NO.	DESCRIPTION	QTY
1	2502-104	1/4-20 X 1/2 HHCS GR. 5 ZYD.	2
2	2502-351	1/2-13 X 2 HHCS GR.5 ZP	5
3	2502-379	M12 X 1.75 X 35 GRD 10.9 ZYD	2
4	2515-846	MALE CONNECTOR - 3/8 X 1/4 NPTF	1
5	2520-151	1/4-20 HEX NUT ZP	2
6	2520-253	3/8-16 JAM HEX NUT ZP	2
7	2520-361	1/2-13 FLANGE WHZLCK HXNT, GR 5, ZP	2
8	2520-464	5/8-11 WHIZLOCK HEX NUT, GR 2, ZP	1
9	2525-151	1/4 MED. LOCKWASHER ZP.	2
10	2525-251	3/8 MED. LOCKWASHER ZP.	1
11	2525-352	1/2 MED LOCKWASHER ZP.	5
12	2526-253	3/8 SAE FLATWASHER ZP	2
13	2526-454	5/8 SAE FLATWASHER HRD'ND ZP	1
14	2570-724	3/8 HOSE P-CLIP W/ VINYL CUSHION	2
15	2968-218	INJECTOR HOLDER W.A.	1
16	2968-222	W.A. CLOSE WHEEL MOUNT, DUAL FERT	1
17	2968-361	ARM CLAMP	1
18	2968-363	HOSE HOLDER, FORMED	1
19	2968-359-RH	SHORT FERT. WHEEL MOUNT, RH	1

PARTS IDENTIFICATION

2968-021A

ROW UNIT MT FERT., JD 7000 & KINZE 2000, LESS BLADE ASS'Y

2968-021A-L-LB

(JD 7000 & KINZE 2000)

ITEM	PART NO.	DESCRIPTION	QTY
1	2502-104	1/4-20 X 1/2 HHCS GR. 5 ZYD.	1
2	2502-245	3/8-16 X 1-3/4 HHCS GR 5 ZP	1
3	2502-351	1/2-13 X 2 HHCS GR.5 ZP	3
4	2502-362	1/2-13 X 5 HHCS GR. 5 ZP	1
5	2502-368	1/2-13 X 5-1/2 HHCS GR5 ZP	1
6	2502-372	1/2-13 X 6-1/2 HHCS GR5 ZP	1
7	2515-846	MALE CONNECTOR - 3/8 X 1/4 NPTF	1
8	2520-151	1/4-20 HEX NUT ZP	1
9	2520-253	3/8-16 JAM HEX NUT ZP	2
10	2520-357	1/2-13 LOCK HEX NUT, GR A, ZP	2
11	2520-464	5/8-11 WHIZLOCK HEX NUT, GR 2, ZP	1
12	2525-151	1/4 MED. LOCKWASHER ZP.	1
13	2525-251	3/8 MED. LOCKWASHER ZP.	1
14	2525-352	1/2 MED LOCKWASHER ZP.	3
15	2526-253	3/8 SAE FLATWASHER ZP	3
16	2526-352	1/2 SAE FLATWASHER ZP	4
17	2526-402	9/16ID X 1-3/4 OD X 1/4MBZP	2
18	2526-454	5/8 SAE FLATWASHER HRD'ND ZP	1
19	2570-724	3/8 HOSE P-CLIP W/ VINYL CUSHION	1
20	2968-218	INJECTOR HOLDER W.A.	1
21	2968-223	CLOSE WHEEL MOUNT PLATE W.A.	1
22	2968-359-LH	SHORT FERT. WHEEL MOUNT, LH	1
23	2968-361	ARM CLAMP	1
24	2968-363	HOSE HOLDER, FORMED	1
25	2968-370	GAUGE WHEEL ARM STOP	1
26	2968-373	SPACER	2
27	6000-523	ECCENTRIC BUSHING CLOSE WHEEL	2

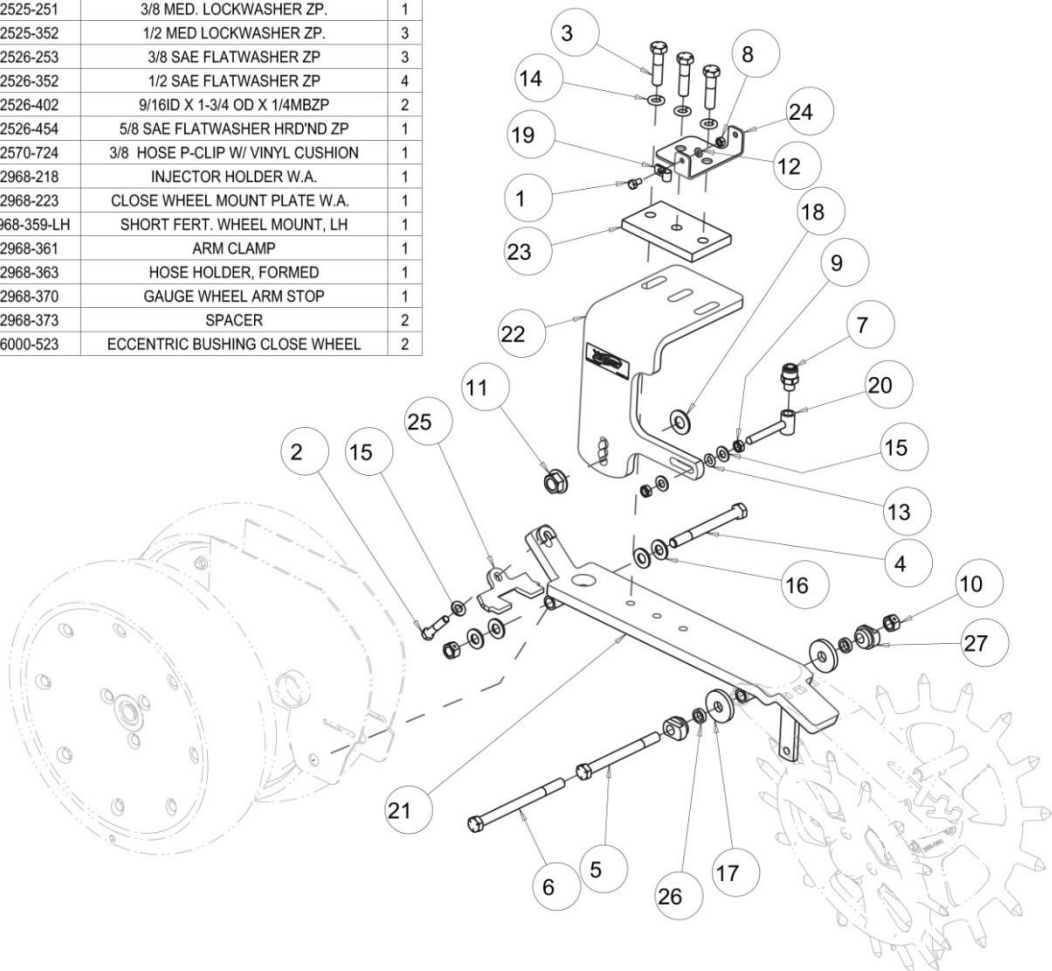
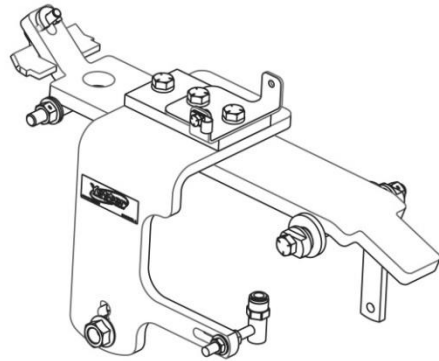

PARTS IDENTIFICATION

2968-021A

ROW UNIT MT FERT., JD 7000 & KINZE 2000, LESS BLADE ASS'Y

2968-021A-R-LB
(JD 7000 & KINZE 2000)

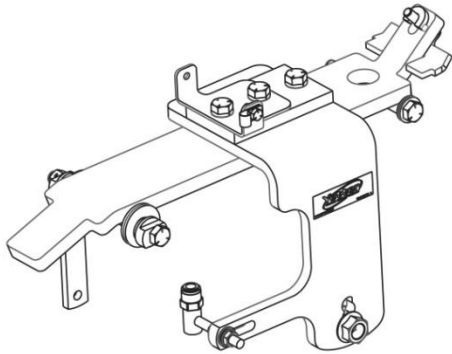

ITEM	PART NO.	DESCRIPTION	QTY
1	2502-104	1/4-20 X 1/2 HHCS GR. 5 ZYD.	1
2	2502-245	3/8-16 X 1-3/4 HHCS GR 5 ZP	1
3	2502-351	1/2-13 X 2 HHCS GR.5 ZP	3
4	2502-362	1/2-13 X 5 HHCS GR. 5 ZP	1
5	2502-368	1/2-13 X 5-1/2 HHCS GR5 ZP	1
6	2502-372	1/2-13 X 6-1/2 HHCS GR5 ZP	1
7	2515-846	MALE CONNECTOR - 3/8 X 1/4 NPTF	1
8	2520-151	1/4-20 HEX NUT ZP	1
9	2520-253	3/8-16 JAM HEX NUT ZP	2
10	2520-357	1/2-13 LOCK HEX NUT, GR A, ZP	2
11	2520-464	5/8-11 WHIZLOCK HEX NUT, GR 2, ZP	1
12	2525-151	1/4 MED. LOCKWASHER ZP.	1
13	2525-251	3/8 MED. LOCKWASHER ZP.	1
14	2525-352	1/2 MED LOCKWASHER ZP.	3
15	2526-253	3/8 SAE FLATWASHER ZP	3
16	2526-352	1/2 SAE FLATWASHER ZP	4
17	2526-402	9/16ID X 1-3/4 OD X 1/4MBZP	2
18	2526-454	5/8 SAE FLATWASHER HRD'ND ZP	1
19	2570-724	3/8 HOSE P-CLIP W/ VINYL CUSHION	1
20	2968-218	INJECTOR HOLDER W.A.	1
21	2968-223	CLOSE WHEEL MOUNT PLATE W.A.	1
22	2968-361	ARM CLAMP	1
23	2968-363	HOSE HOLDER, FORMED	1
24	2968-370	GAUGE WHEEL ARM STOP	1
25	2968-373	SPACER	2
26	2968-359-RH	SHORT FERT. WHEEL MOUNT, RH	1
27	6000-523	ECCENTRIC BUSHING CLOSE WHEEL	2

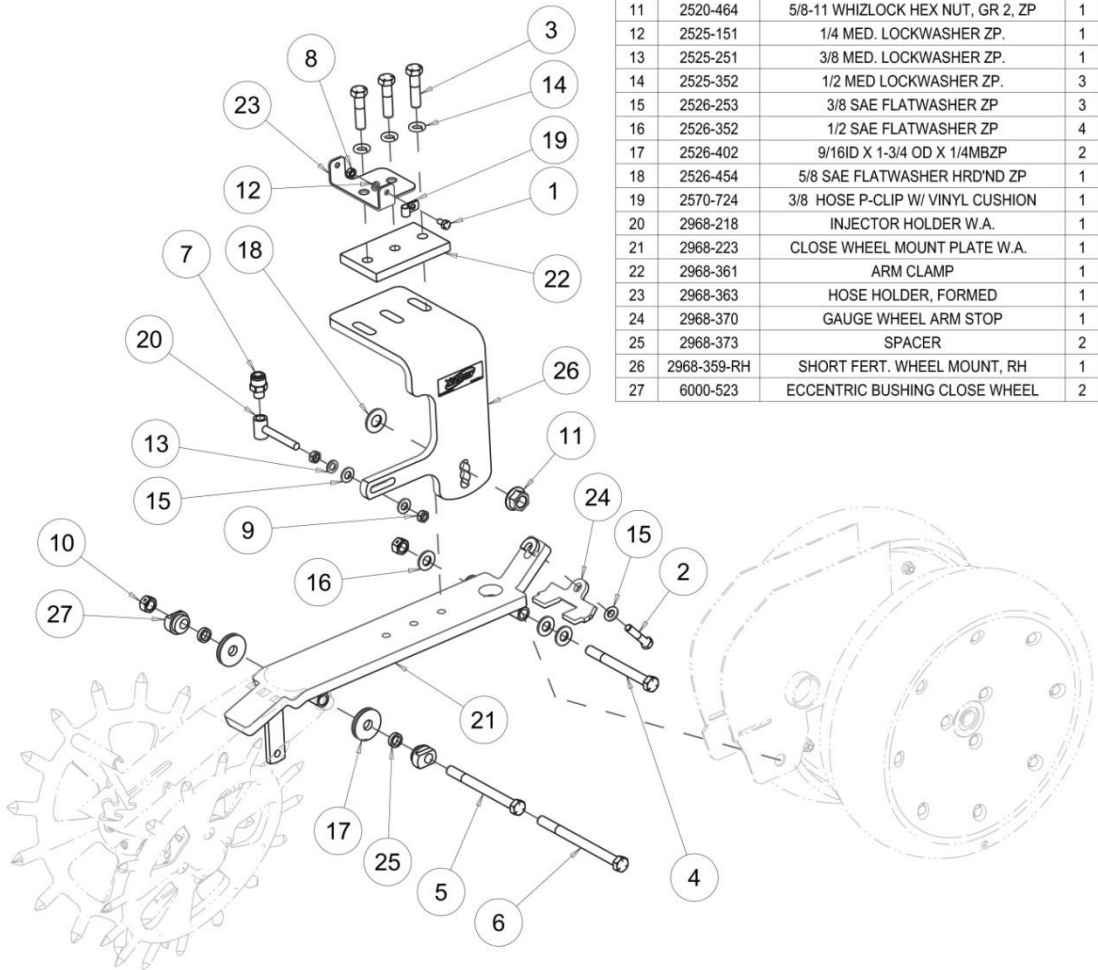

PARTS IDENTIFICATION

2968-021A

ROW UNIT MT FERT., KINZE 3000, LESS BLADE ASS'Y

2968-021A-L-LB

(KINZE 3000)

ITEM	PART NO.	DESCRIPTION	QTY
1	2502-104	1/4-20 X 1/2 HHCS GR. 5 ZYD.	1
2	2502-232	3/8-16 X 1 1/2 HHCS GR 5 ZYD	1
3	2502-351	1/2-13 X 2 HHCS GR.5 ZP	3
4	2502-362	1/2-13 X 5 HHCS GR. 5 ZP	1
5	2502-368	1/2-13 X 5-1/2 HHCS GR5 ZP	1
6	2502-372	1/2-13 X 6-1/2 HHCS GR5 ZP	1
7	2515-846	MALE CONNECTOR - 3/8 X 1/4 NPTF	1
8	2520-151	1/4-20 HEX NUT ZP	1
9	2520-253	3/8-16 JAM HEX NUT ZP	2
10	2520-357	1/2-13 LOCK HEX NUT, GR A, ZP	2
11	2520-464	5/8-11 WHIZLOCK HEX NUT, GR 2, ZP	1
12	2525-151	1/4 MED. LOCKWASHER ZP.	1
13	2525-251	3/8 MED. LOCKWASHER ZP.	1
14	2525-352	1/2 MED LOCKWASHER ZP.	3
15	2526-253	3/8 SAE FLATWASHER ZP	6
16	2526-352	1/2 SAE FLATWASHER ZP	4
17	2526-402	9/16ID X 1-3/4 OD X 1/4MBZP	2
18	2526-454	5/8 SAE FLATWASHER HRD'ND ZP	1
19	2570-724	3/8 HOSE P-CLIP W/ VINYL CUSHION	1
20	2968-218	INJECTOR HOLDER W.A.	1
21	2968-223	CLOSE WHEEL MOUNT PLATE W.A.	1
22	2968-359-LH	SHORT FERT. WHEEL MOUNT, LH	1
23	2968-361	ARM CLAMP	1
24	2968-363	HOSE HOLDER, FORMED	1
25	2968-373	SPACER	2
26	6000-523	ECCENTRIC BUSHING CLOSE WHEEL	2

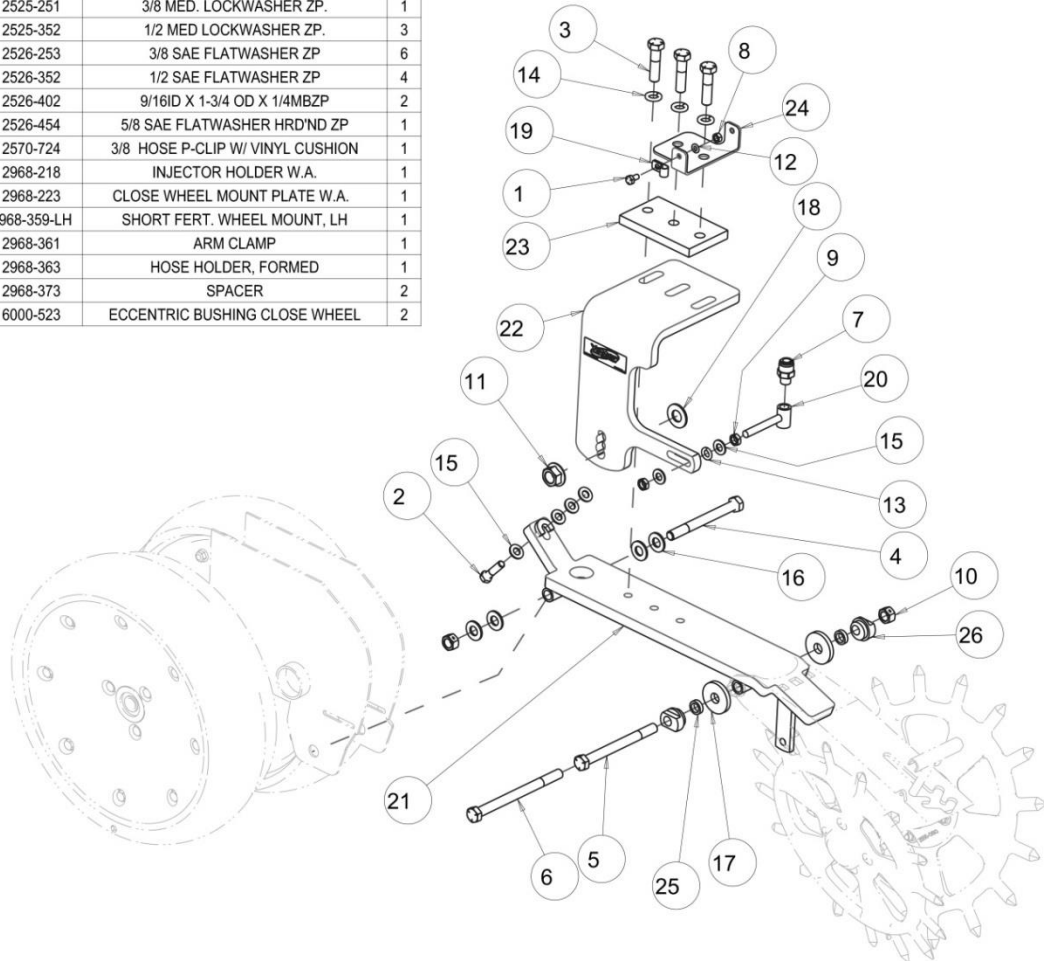
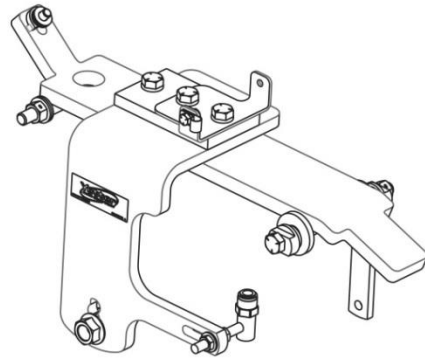

PARTS IDENTIFICATION

2968-021A

ROW UNIT MT FERT., KINZE 3000, LESS BLADE ASS'Y

2968-021A-R-LB

(KINZE 3000)

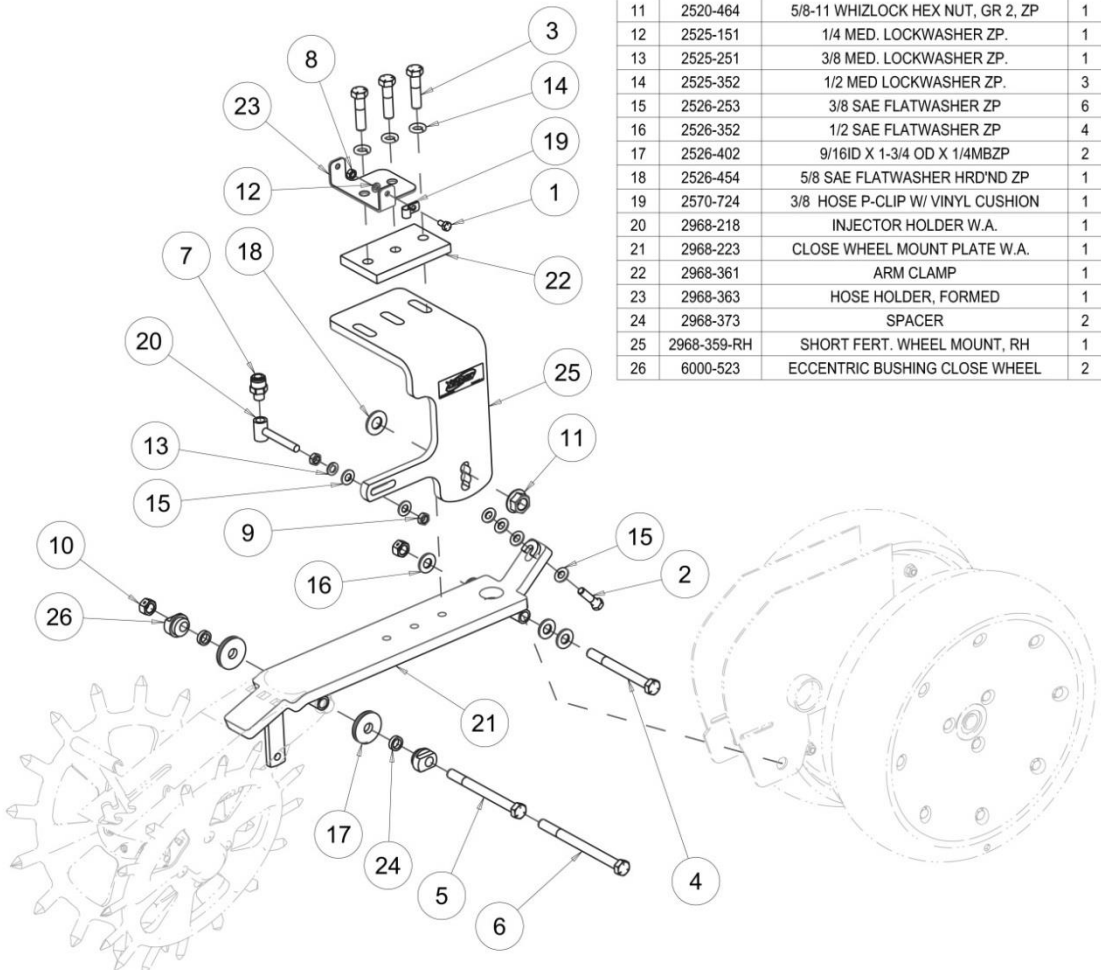
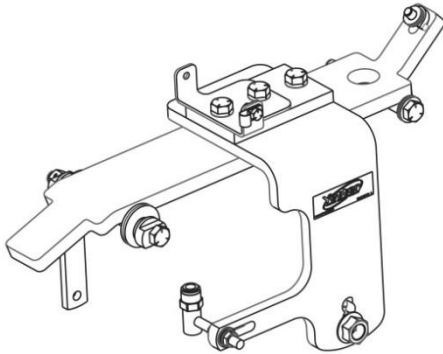

ITEM	PART NO.	DESCRIPTION	QTY
1	2502-104	1/4-20 X 1/2 HHCS GR. 5 ZYD.	1
2	2502-232	3/8-16 X 1 1/2 HHCS GR 5 ZYD	1
3	2502-351	1/2-13 X 2 HHCS GR.5 ZP	3
4	2502-362	1/2-13 X 5 HHCS GR. 5 ZP	1
5	2502-368	1/2-13 X 5-1/2 HHCS GR5 ZP	1
6	2502-372	1/2-13 X 6-1/2 HHCS GR5 ZP	1
7	2515-846	MALE CONNECTOR - 3/8 X 1/4 NPTF	1
8	2520-151	1/4-20 HEX NUT ZP	1
9	2520-253	3/8-16 JAM HEX NUT ZP	2
10	2520-357	1/2-13 LOCK HEX NUT, GR A, ZP	2
11	2520-464	5/8-11 WHIZLOCK HEX NUT, GR 2, ZP	1
12	2525-151	1/4 MED. LOCKWASHER ZP.	1
13	2525-251	3/8 MED. LOCKWASHER ZP.	1
14	2525-352	1/2 MED LOCKWASHER ZP.	3
15	2526-253	3/8 SAE FLATWASHER ZP	6
16	2526-352	1/2 SAE FLATWASHER ZP	4
17	2526-402	9/16ID X 1-3/4 OD X 1/4MBZP	2
18	2526-454	5/8 SAE FLATWASHER HRD'ND ZP	1
19	2570-724	3/8 HOSE P-CLIP W/ VINYL CUSHION	1
20	2968-218	INJECTOR HOLDER W.A.	1
21	2968-223	CLOSE WHEEL MOUNT PLATE W.A.	1
22	2968-361	ARM CLAMP	1
23	2968-363	HOSE HOLDER, FORMED	1
24	2968-373	SPACER	2
25	2968-359-RH	SHORT FERT. WHEEL MOUNT, RH	1
26	6000-523	ECCENTRIC BUSHING CLOSE WHEEL	2

PARTS IDENTIFICATION

2968-040-LB

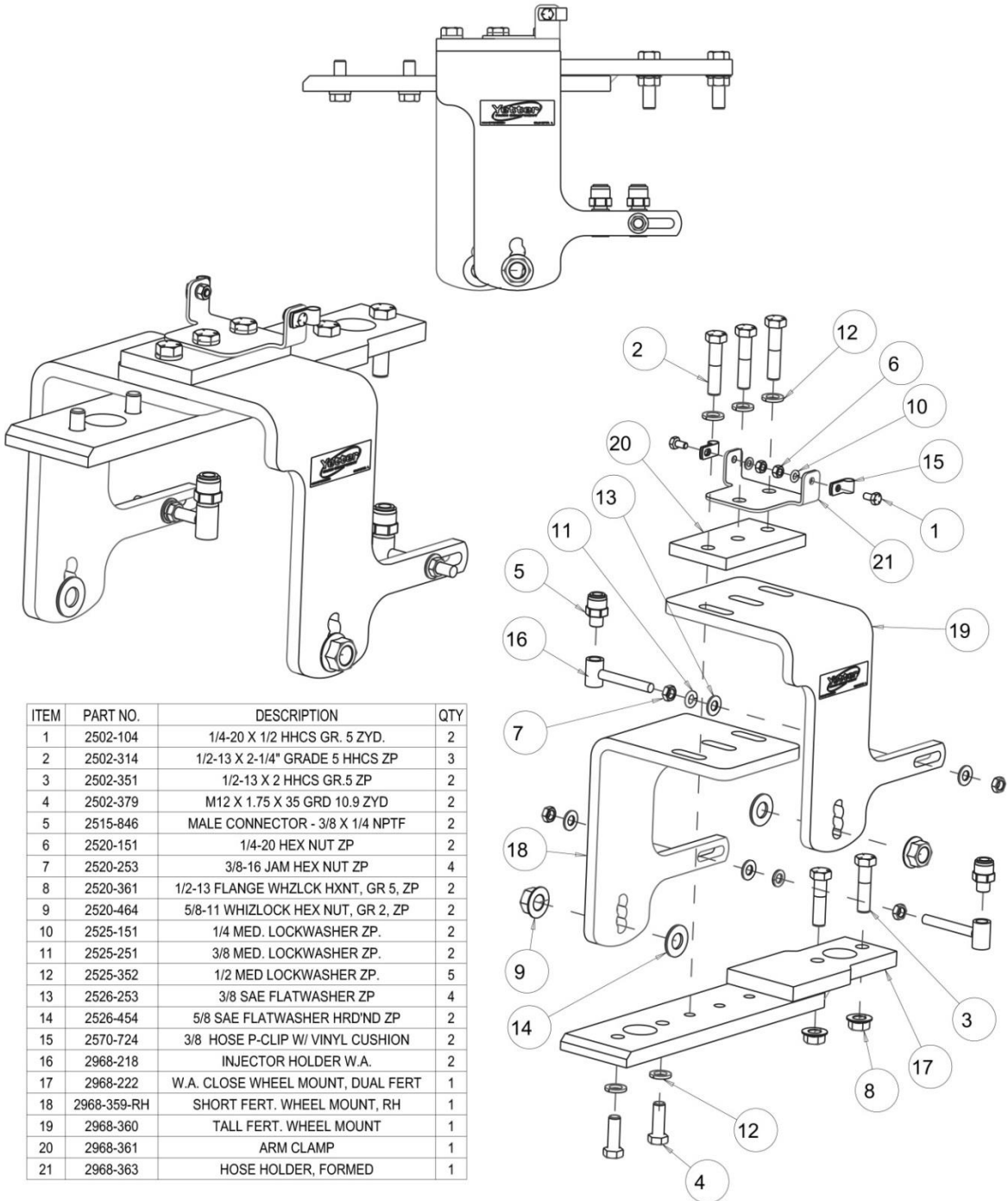

ITEM	PART NO.	DESCRIPTION	QTY
1	2502-104	1/4-20 X 1/2 HHCS GR. 5 ZYD.	2
2	2502-314	1/2-13 X 2-1/4" GRADE 5 HHCS ZP	3
3	2502-351	1/2-13 X 2 HHCS GR.5 ZP	2
4	2502-379	M12 X 1.75 X 35 GRD 10.9 ZYD	2
5	2515-846	MALE CONNECTOR - 3/8 X 1/4 NPTF	2
6	2520-151	1/4-20 HEX NUT ZP	2
7	2520-253	3/8-16 JAM HEX NUT ZP	4
8	2520-361	1/2-13 FLANGE WHZLCK HXNT, GR 5, ZP	2
9	2520-464	5/8-11 WHIZLOCK HEX NUT, GR 2, ZP	2
10	2525-151	1/4 MED. LOCKWASHER ZP.	2
11	2525-251	3/8 MED. LOCKWASHER ZP.	2
12	2525-352	1/2 MED LOCKWASHER ZP.	5
13	2526-253	3/8 SAE FLATWASHER ZP	4
14	2526-454	5/8 SAE FLATWASHER HRD'ND ZP	2
15	2570-724	3/8 HOSE P-CLIP W/ VINYL CUSHION	2
16	2968-218	INJECTOR HOLDER W.A.	2
17	2968-222	W.A. CLOSE WHEEL MOUNT, DUAL FERT	1
18	2968-359-RH	SHORT FERT. WHEEL MOUNT, RH	1
19	2968-360	TALL FERT. WHEEL MOUNT	1
20	2968-361	ARM CLAMP	1
21	2968-363	HOSE HOLDER, FORMED	1

PARTS IDENTIFICATION

2968-041-LB

DUAL ROW UNIT MT FERT., KINZE/JD, LESS BLADE ASS'Y

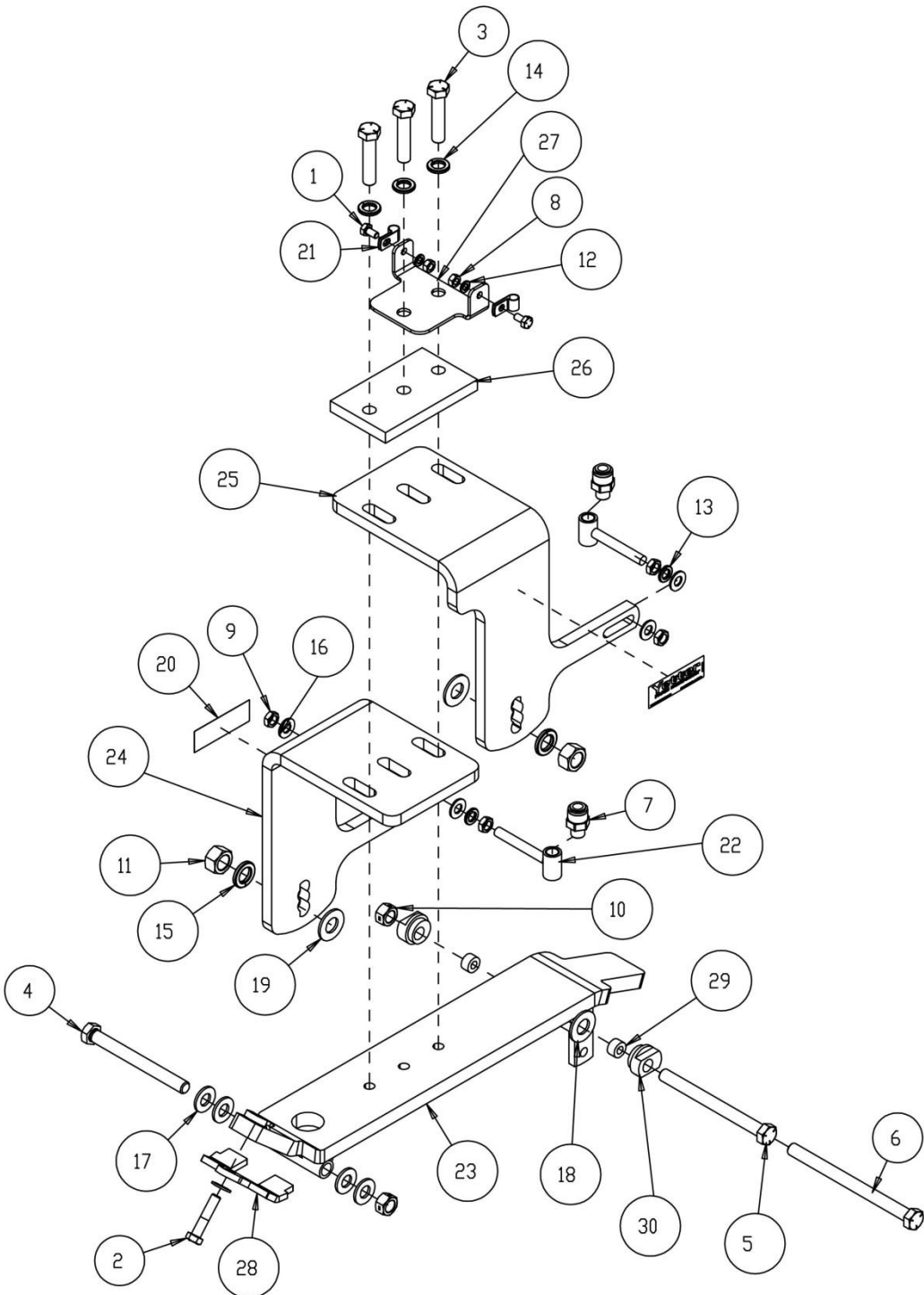

PARTS IDENTIFICATION

2968-041-LB

DUAL ROW UNIT MT FERT., KINZE/JD, LESS BLADE ASS'Y

ITEM	PART NO.	DESCRIPTION	QTY
1	2502-104	1/4-20 X 1/2 HHCS GR. 5 ZYD.	2
2	2502-245	3/8-16 X 1-3/4 HHCS GR 5 ZP	1
3	2502-314	1/2-13 X 2-1/4" GRADE 5 HHCS ZYD	3
4	2502-362	1/2-13 X 5 HHCS GR. 5 ZP	1
5	2502-368	1/2-13 X 5-1/2 HHCS GR5 ZP	1
6	2502-372	1/2-13 X 6-1/2 HHCS GR5 ZP	1
7	2515-846	MALE CONNECTOR - 3/8 X 1/4 NPTF	2
8	2520-151	1/4-20 HEX NUT ZP	2
9	2520-253	3/8-16 JAM HEX NUT ZP	4
10	2520-357	1/2-13 LOCK HEX NUT, GR A, ZP	2
11	2520-452	5/8-11 HEXNUT ZP	2
12	2525-151	1/4 MED. LOCKWASHER ZP.	2
13	2525-251	3/8 MED. LOCKWASHER ZP.	2
14	2525-352	1/2 MED LOCKWASHER ZP.	3
15	2525-451	5/8 MED. LOCKWASHER ZP.	2
16	2526-253	3/8 SAE FLATWASHER ZP	5
17	2526-352	1/2 SAE FLATWASHER ZP	4
18	2526-402	9/16ID X 1-3/4 OD X 1/4MBZP	2
19	2526-454	5/8 SAE FLATWASHER HRD'ND ZP	2
20	2565-179	YETTER DECAL 1" X 3"	2
21	2570-724	3/8 HOSE P-CLIP W/ VINYL CUSHION	2
22	2968-218	INJECTOR HOLDER W.A.	2
23	2968-223	CLOSE WHEEL MOUNT PLATE W.A.	1
24	2968-359-RH	SHORT FERT. WHEEL MOUNT, RH	1
25	2968-360	TALL FERT. WHEEL MOUNT	1
26	2968-361	ARM CLAMP	1
27	2968-363	HOSE HOLDER, FORMED	1
28	2968-370	GAUGE WHEEL ARM STOP	1
29	2968-373	SPACER	2
30	6000-523	ECCENTRIC BUSHING CLOSE WHEEL	2

PARTS IDENTIFICATION

2968-132 (SHOWN) 10" WHEEL ASSEMBLY

2968-133 11" WHEEL ASSEMBLY

MUST ALIGN GREASE ZERK WITH ALL GREASE GROOVES

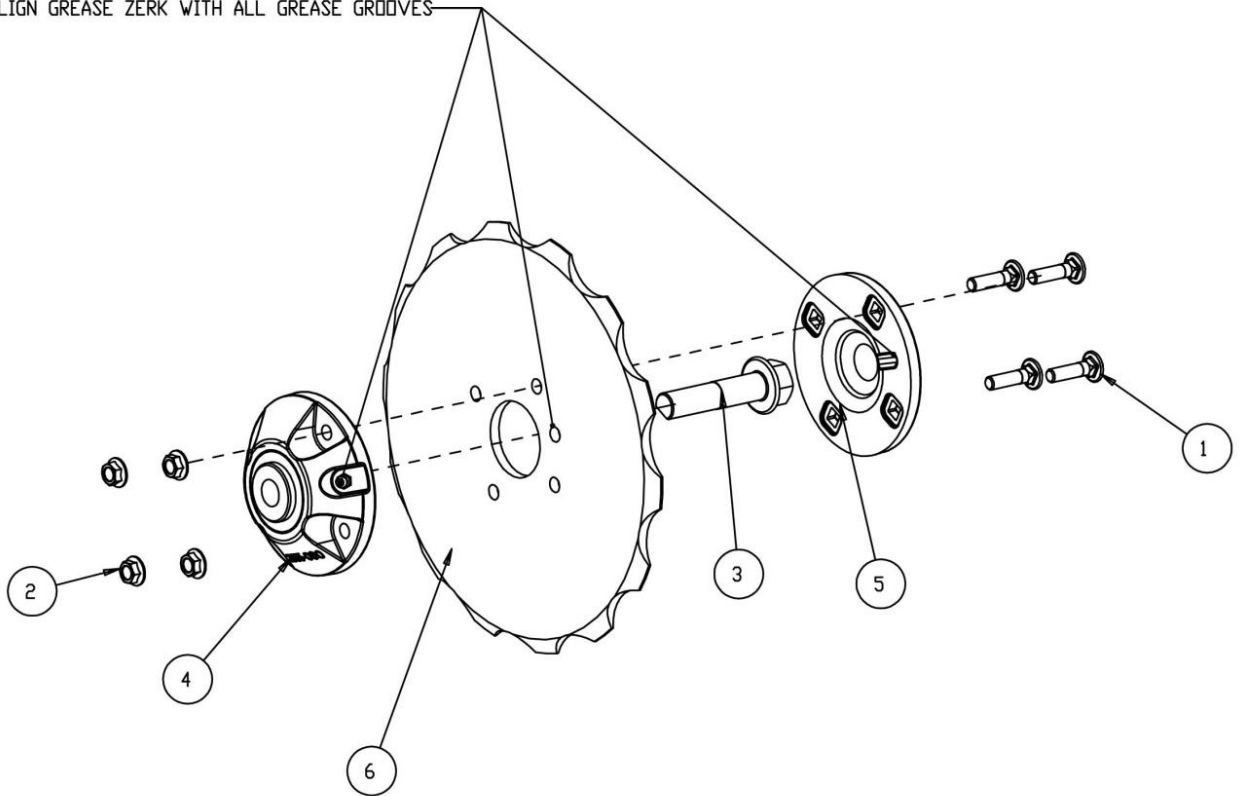

ITEM	PART NO.	DESCRIPTION	QTY
1	2505-207	5/16-18 X 1 1/4 CARBLT G5 ZP	4
2	2520-206	5/16-18 FLANGE LOCK NUT	4
3	2570-740	D-BOLT, FLGD, 5/8-11 X 2.812 GR. 8	1
4	2965-128	HUB AND BEARING, 4 BOLT	1
5	2965-352	HUB CAP, 4 BOLT, BLACK	1
6	2968-320	10.05 X .256 FERTILIZER WHEEL (SHOWN)	1
	2968-364	11.05 X .256 FERTILIZER WHEEL	1

PHOTO I.D.

2968-020A-R



PHOTO I.D.

2968-020A-R

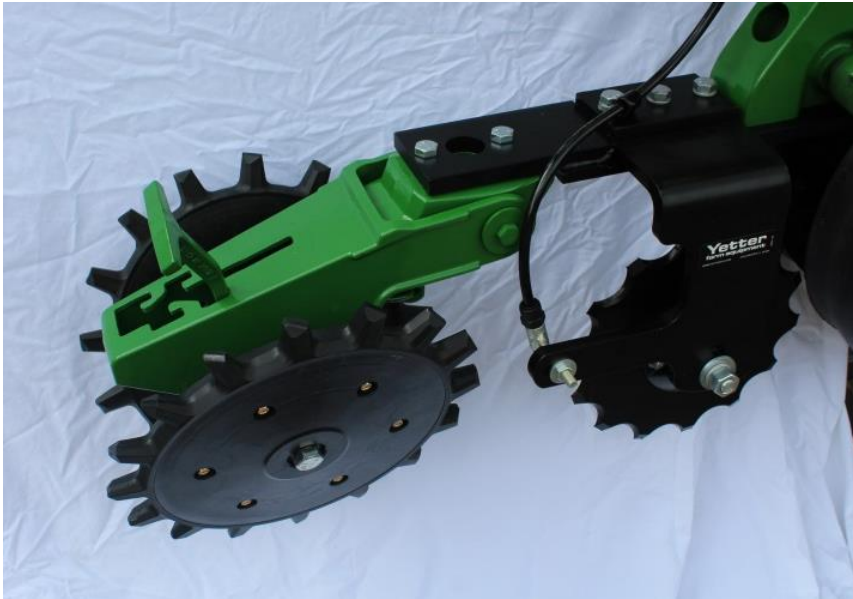

PHOTO I.D.

2968-020A-R



PHOTO I.D.

2968-040

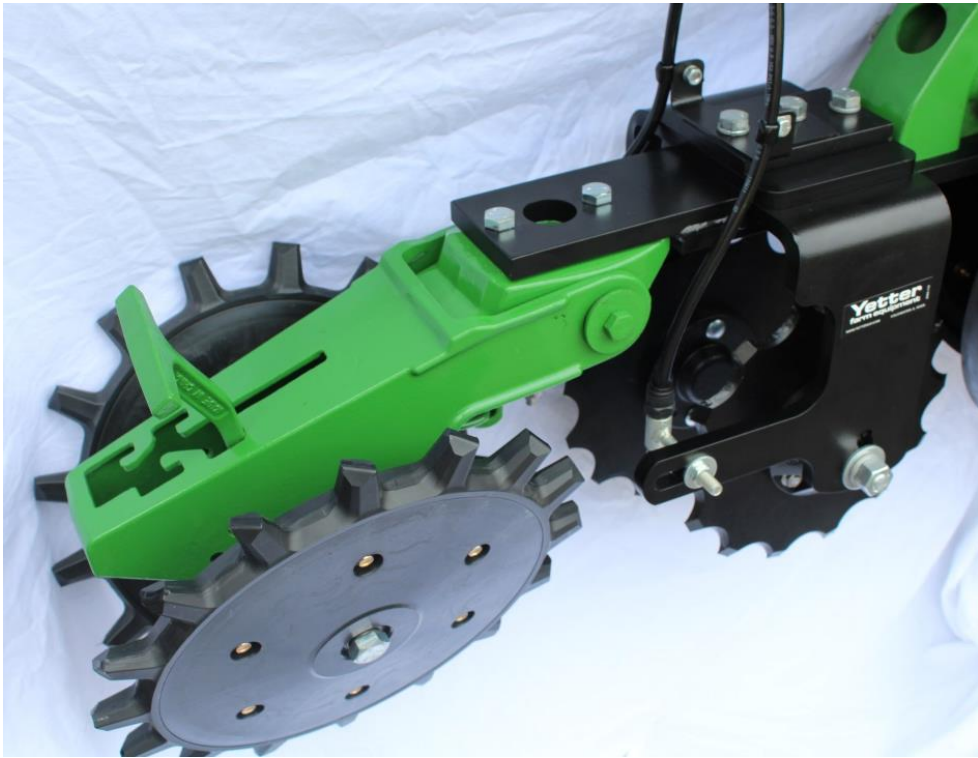

PHOTO I.D.

2968-040

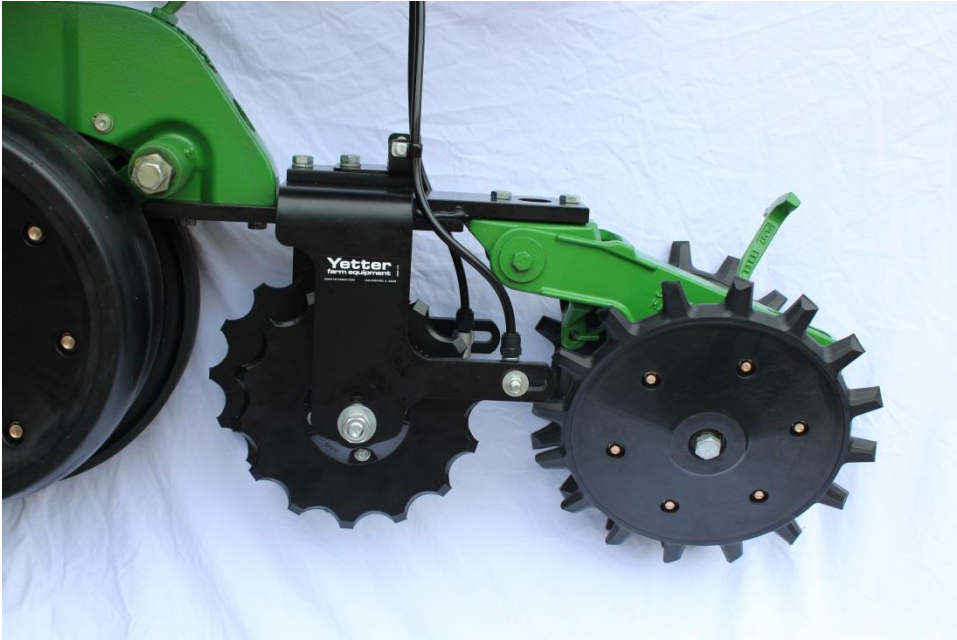

PHOTO I.D.

2968-040



PHOTO I.D.

2968-040



Our name Is getting known

Just a few years ago, Yetter products were sold primarily to the Midwest only. Then we embarked on a program of expansion and moved into the East, the South, the West and now north into Canada. We're even getting orders from as far away as Australia and Africa.

So, when you buy Yetter products . . .you're buying a name that's recognized. A name that's known and respected. A name that's become a part of American agriculture and has become synonymous with quality and satisfaction in the field of conservation tillage.

Thank you.

YETTER MANUFACTURING CO.

Colchester, IL 62326-0358 • 309/776-4111

Toll Free 800/447-5777

Fax 309/776-3222

Website: WWW.YETTERCO.COM

E-MAIL: INFO@YETTERCO.COM

2565-951_REV B1 • 08/2024