



# SCREW ADJUST

RESIDUE MANAGER

OPERATOR'S MANUAL

PARTS IDENTIFICATION

2565-729\_REV\_M • 08/2023

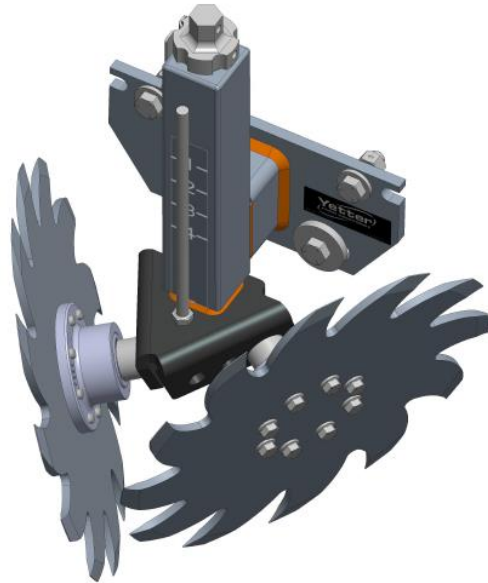

**YETTER MANUFACTURING CO.**

*FOUNDED 1930*

Colchester, IL 62326-0358

Toll free: 800/447-5777

309/776-3222 (Fax)

Website: [www.yetterco.com](http://www.yetterco.com)

E-mail: [info@yetterco.com](mailto:info@yetterco.com)

**YETTER**

# FOREWORD

You've just joined an exclusive but rapidly growing club.

For our part, we want to welcome you to the group and thank you for buying a Yetter product.

We hope your new Yetter products will help you achieve both goals-increase your productivity and increase your efficiency so that you may generate more profit.

This operator's manual has been designed into four major sections: Foreword, Safety Precautions, Installation Instructions and Parts Breakdown.

 This **SAFETY ALERT SYMBOL** indicates important safety messages in the manual. When you see this symbol, be alert to the possibility of **PERSONAL INJURY** and carefully read the message that follows.

 **DANGER:** Indicates an imminently hazardous situation which, if not avoided "will" result in death or serious injury. This signal word is to be limited to the most extreme situations

 **WARNING:** Indicates a potentially hazardous situation which, if not avoided, "could" result in death or serious injury.

 **CAUTION:** Indicates a potentially hazardous situation, which if not avoided, "may" result in minor or moderate injury. It may also be used to alert against unsafe practices.

 **NOTICE:** Indicates information considered important, but not hazard related (e.g., messages relating to property damage).

It is the responsibility of the user to read the operator's manual and comply with the safe and correct operating procedure and to lubricate and maintain the product according to the maintenance schedule in the operator's manual.

The user is responsible for inspecting his machine and for having parts repaired or replaced when continued use of the product would cause damage or excessive wear to the other parts.

It is the user's responsibility to deliver his machine to the Yetter dealer who sold him the product for service or replacement of defective parts, which are covered by the warranty policy.

If you are unable to understand or follow the instructions provided in this publication, consult your local Yetter dealer or contact:

## YETTER MANUFACTURING CO.

309/776-4111

800/447-5777

309/776-3222 (FAX)

Website: [www.yetterco.com](http://www.yetterco.com)

E-mail: [info@yetterco.com](mailto:info@yetterco.com)

## WARRANTY

Yetter Manufacturing warrants all products manufactured and sold by it against defects in material. This warranty being expressly limited to replacement at the factory of such parts or products as shall appear to be defective after inspection. This warranty does not obligate the Company to bear cost of labor in replacement of parts. It is the policy of the Company to make improvements without incurring obligations to add them to any unit already sold. No warranty is made or authorized to be made, other than herein set forth. This warranty is in effect for one year after purchase.

DEALER: \_\_\_\_\_

**Yetter Manufacturing warrants its own products only and cannot be responsible for damages to equipment on which mounted.**



## SAFETY PRECAUTIONS



A brief description of signal words that may be used in this manual:

**DANGER**: Indicates an imminently hazardous situation which, if not avoided “will” result in death or serious injury. This signal word is to be limited to the most extreme situations.

**WARNING**: Indicates a potentially hazardous situation which, if not avoided, “could” result in death or serious injury.

**CAUTION**: Indicates a potentially hazardous situation, which if not avoided, “may” result in minor or moderate injury. It may also be used to alert against unsafe practices.

**NOTICE**: Indicates information considered important, but not hazard related (e.g., messages relating to property damage).

Consult your implement and tractor operator’s manual for correct and safe operating practices. Be aware of towed implement width and allow safe clearance.

Safety decals are placed on the implement to alert the operator and others to the risk of personal injury or unsafe operation during normal operations and servicing.

1. The safety decals must be kept clean and in good condition to ensure that they are legible.
2. Safety decals must be replaced if they are missing or illegible.
3. When components are replaced during repair or servicing, check that the new components include the necessary safety signs.
4. Replacement safety decals may be obtained from your local dealer.



### WARNING

Read these instructions carefully to acquaint yourself with the Equipment. Working with unfamiliar equipment can lead to accidents.

Never park the equipment on a steep incline or leave the equipment running unattended.

Never clean, lubricate or adjust a machine that is in motion.

Always check that straps are secure.

Make sure latches are in pinned position when moving equipment.

Do not allow children to operate this equipment.

Do not allow riders on the equipment, trailer and/or pick-up.

Use speed and caution dictated by the terrain being traversed. Do not operate on any slope steep enough to cause tipping or loss of control.

Read and understand the operator’s manual and require all other persons who will operate the equipment to do the same.

If operating on public roadways, where legal, be certain all lighting is operating properly and observe all traffic laws.

Beware of increased stopping distances and control effort when operating with implements attached.

Be familiar with all controls and be prepared to stop equipment quickly in an emergency.

**FAILURE TO HEED MAY RESULT IN PERSONAL INJURY OR DEATH.**

# TABLE OF CONTENTS

Forward.....	2
Warranty.....	2
Safety Information.....	2-3
Table of Contents.....	4
Bolt Torque.....	5
Planter Adjustments.....	6-8
Installations Instructions.....	9-11
Maintenance.....	12-13
Parts Identification.....	14-31

# BOLT TORQUE

## Mounting bolts and hardware

Before operating the Residue Manager for the first time, check to be sure that all hardware is tight. Check all hardware again after approximately 50 hours of operation and at the beginning of each planting season.

All hardware used on the Residue Manager is Grade 5 unless otherwise noted. Grade 5 cap screws are marked with three radial lines on the head. If hardware must be replaced, be sure to replace it with hardware of equal size, strength and thread type. Refer to the torque values chart when tightening hardware.





**NOTICE:** Over tightening hardware can cause as much damage as when under tightening. Tightening hardware beyond the recommended range can reduce its shock load capacity.

The chart below is a guide for proper torque. Use it unless a specified torque is called out elsewhere in the manual.

Torque is the force you apply to the wrench handle or the cheater bar, times the length of the handle or bar.

Use a torque wrench whenever possible.

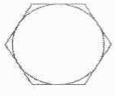
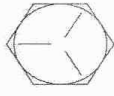
The following table shows torque in ft. lbs. for coarse thread hardware.

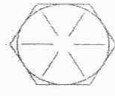
BOLT DIA. AND THREADS PER INCH	 GRADE 2	 OR  GRADE 5 A-325	 GRADE 8
1/4	6	10	14
5/16	12	20	30
3/8 - 16	25	35	50
7/16 - 14	35	55	80
1/2 - 13	55	85	125
9/16 - 12	75	125	175
5/8 - 11	105	170	235
3/4 - 10	185	305	425
7/8 - 9	170	445	690
1-8	260	670	1030
1 1/8 - 7	365	900	1460
1 1/4 - 7	515	1275	2060
1 3/8 - 6	675	1675	2700
1 1/2 - 6	900	2150	3500
1 3/4 - 5	1410	3500	5600

Lubricate all bearings and moving parts as assembled and make certain that they work freely.



**WARNING:** Never work around the toolbar/implement while in a raised position without using safety lockups.



**CAUTION:** The Residue Managers are very heavy and sharp. Pay extra attention to lifting techniques while handling and or maneuvering the opener during assembly. Failure to do so may lead to personal injury.

# OPERATION PRECAUTIONS

## STOP

Read this before using the Yetter product.

### - MACHINE OPERATION



**NOTICE:** failure to properly set the planter frame height and levelness can result in less than successful operation of the planter and the Yetter product and may result in damaged equipment. All operators should read and thoroughly understand the instructions given prior to using the Yetter product.



**NOTICE:** DO NOT use this product if the planter is not adjusted properly!

Leveling the planter:

With the planter lowered to proper operating height (**Usually 20"-22"**).

**Read the planter operator's manual for recommended setting.** Check to be sure the toolbar and row unit parallel arms are level fore and aft. **Re-check** when the planter is in the **field** and has been **fully loaded** with seed, fertilizer, granular chemicals, etc. Also, a field check with a bubble level on the frame should be made of the hitch height to ensure level operation front to back.

It is important for the planter to operate level laterally. Tire pressure must be maintained at pressures specified by the manufacturer.

Field and actual planting conditions change and will dictate planter frame heights. You must ensure that the row unit parallel arms are approximately parallel with the ground.



**NOTICE:** For proper operation of the planter attachments and row units, it is imperative that the planter toolbars and row unit parallel arms be level side-to-side and front-to-rear. The toolbar frame should operate at a 20"-22" height from the **planting surface**. Check the manufacturer's operator's manual for instructions on how to adjust the frame height and levelness.

# PLANTER ADJUSTMENT

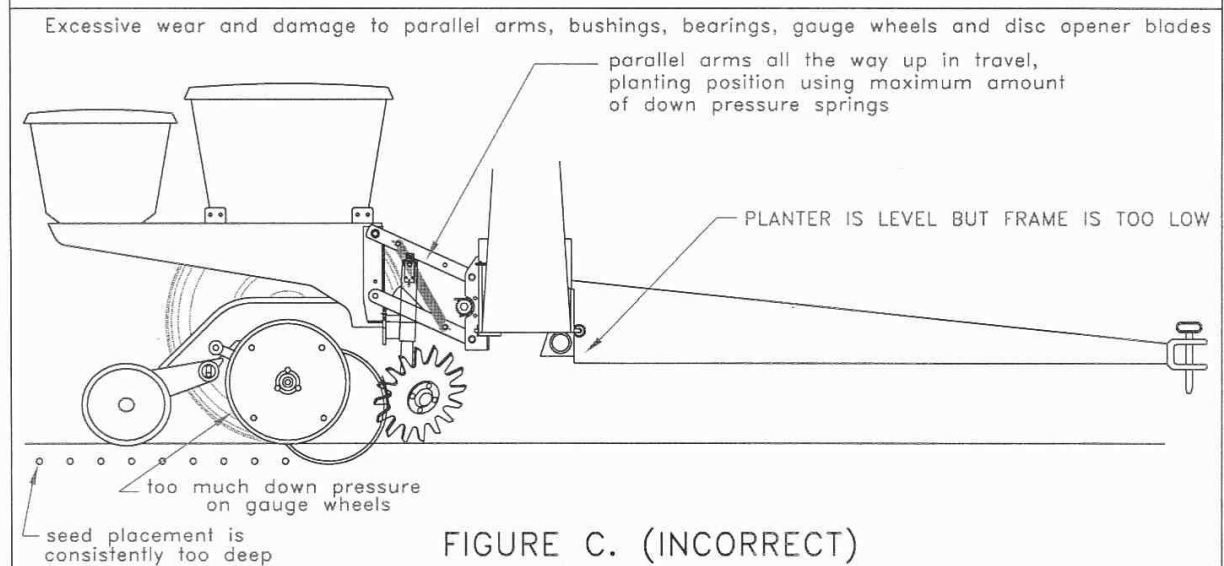
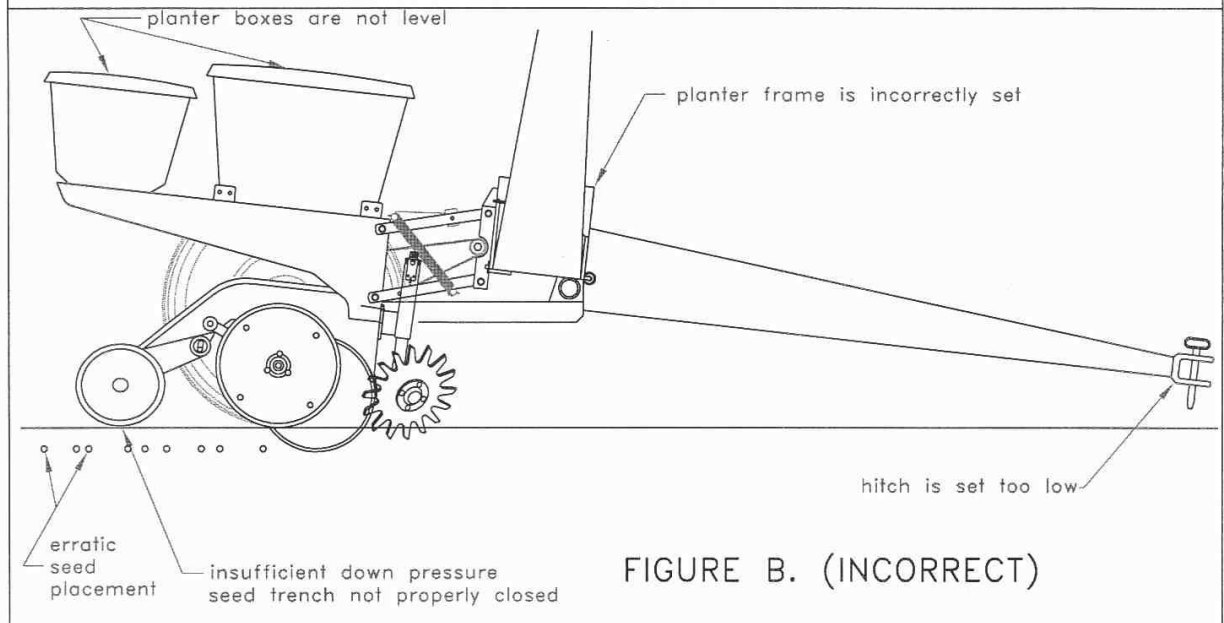
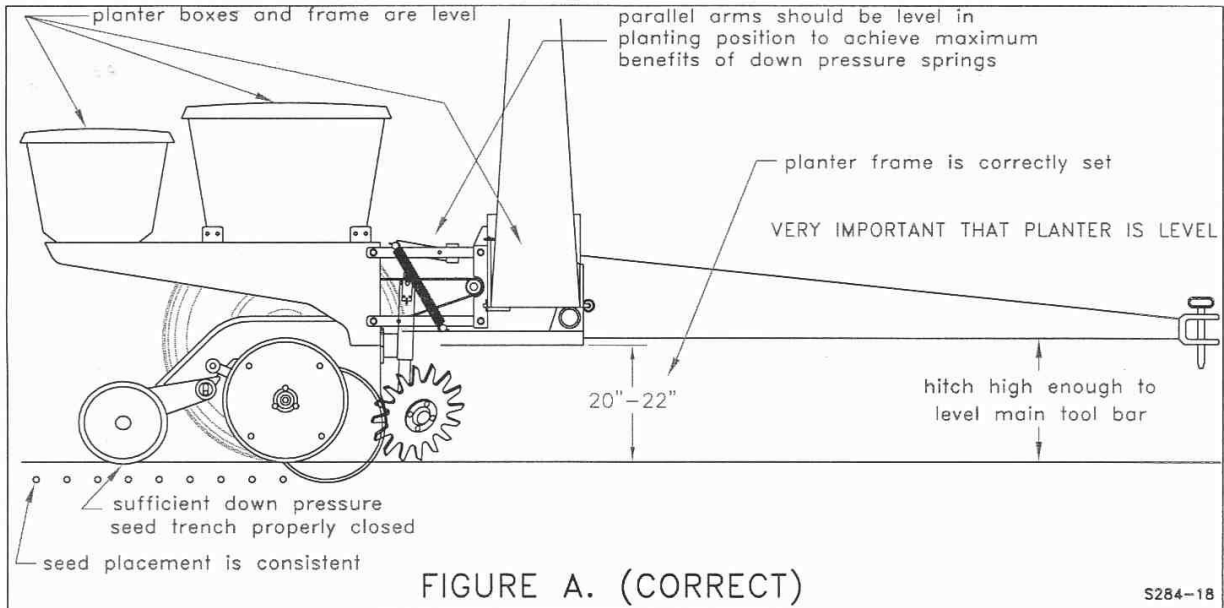

# OPERATION

Be sure planter frame is **LEVEL** and at the height stated in the planter operation manual.

The **Residue Manager** is designed to work in heavy residue situations especially where minimum soil movement is required. Depending on conditions and objectives, the 2967 Residue Manager can be set shallow with the teeth only engaged in the residue so as to clear heavy residue with minimal soil disturbance. Residue Managers are not recommended when surface application pre-plant herbicide is used prior to planting.

## ROW CLEANER DO'S AND DON'TS

1. **DO NOT** move soil, Residue Managers are designed to move crop residue only.
2. **DO NOT** operate planter at slow speeds, ground speed affects how aggressive the spoke wheels are; operate at sufficient speed to maintain good residue flow.
3. **DO NOT** expect 100% of crop residue to be cleared, it is not necessary and would necessitate engaging the soil. The width of path cleared depends on ground conditions, depth setting and ground speed.
4. **DO** expect to see wheels occasionally quit turning, indicates ideal (shallow) setting which is not moving dirt.
5. **DO** expect the potential to bend or break teeth on wheels in excessively rocky conditions.
6. **DO** adjust planter frame height 20"-22" and level drawbar correctly. Very important to ensure planter unit will follow ground contours properly.
7. **DO** adjust planter row unit down pressure kit correctly to prevent excessive depth.
8. **DO** expect finely tilled/soft soils to require adjustment due to lack of resistance, the wheel must turn to move residue.
9. **DO** expect more adjustments to be required in finely tilled or soft soils. In these conditions, the planter may lose flotation requiring adjustment of the residue manager to shallower positions.



# INSTALLATION INSTRUCTIONS

**STEP 1.** Choose the mounting hole in which to attach the R.M. wheels. Attach the R.M. wheels/hub/shield assemblies to the stem adjustment bracket using 5/8" flange hex nuts. Adjust the bearing shield to top dead center, rotate slightly forward. Torque to 180 ft./lbs.

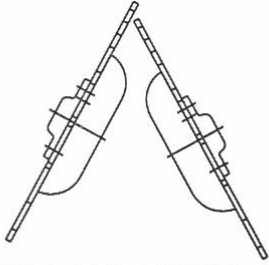

FRONT HOLE/MIDDLE HOLE  
OFFSET

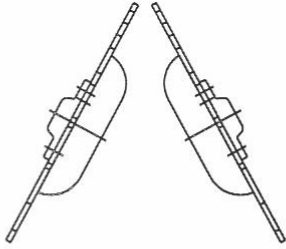

MIDDLE HOLE  
MIDDLE HOLE  
SPACED APART

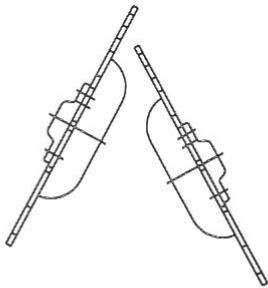

FRONT HOLE  
REAR HOLE  
OFFSET  
RECOMMENDED

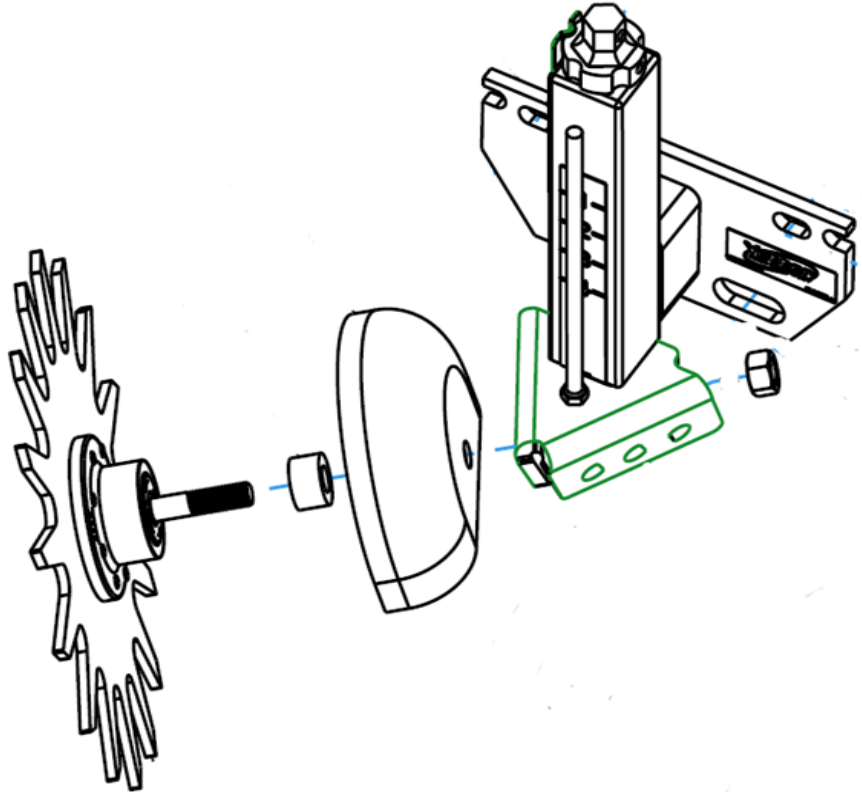

# INSTALLATION INSTRUCTIONS

**STEP 2A.** Attach the screw adjust residue manager assembly to the planter row unit using 2) 1/2" x 3-1/2" hex bolts and 1/2" lock nuts.

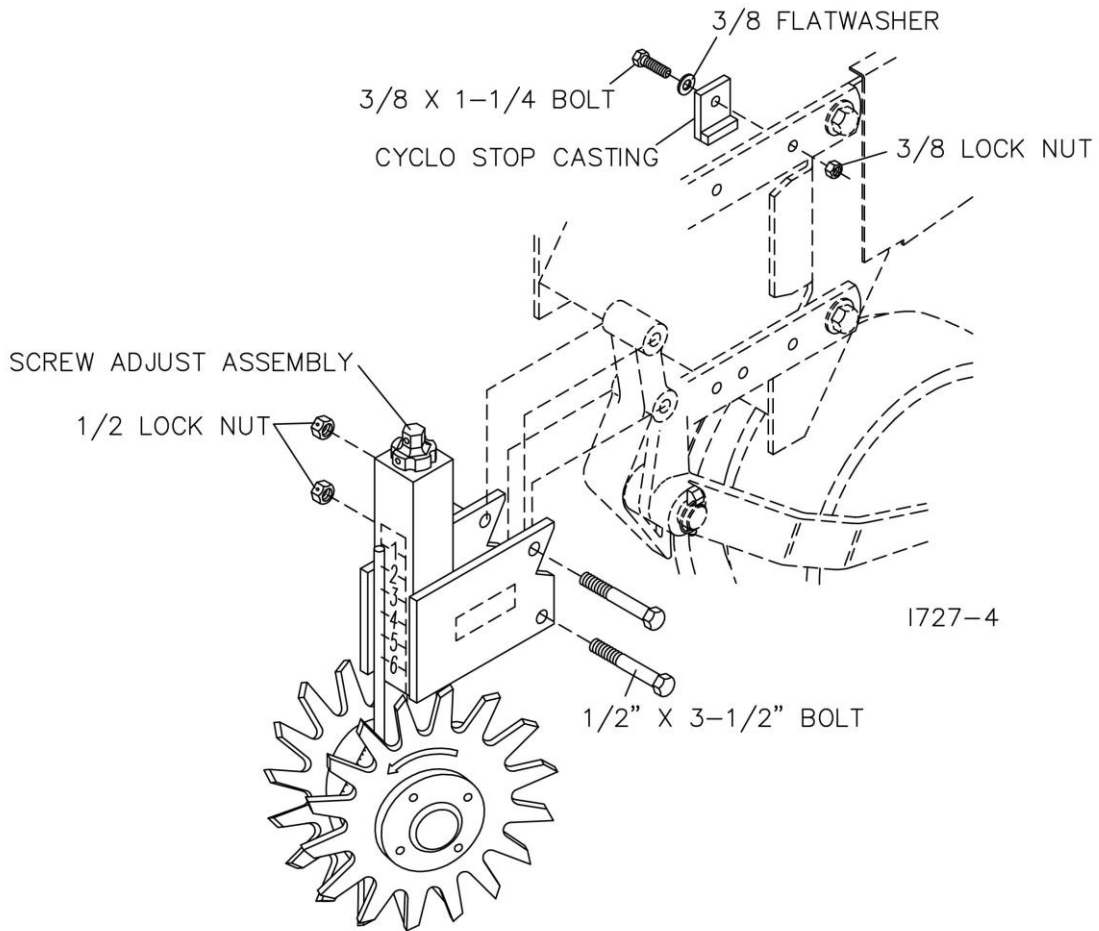

2967-053

## INSTALLATION INSTRUCTIONS

**STEP 2B.** Attach the screw adjust residue manager assembly to the planter row unit using 3) ½" x 1-1/2" hex bolts, flat washers and ½" lock nuts.

2967-052

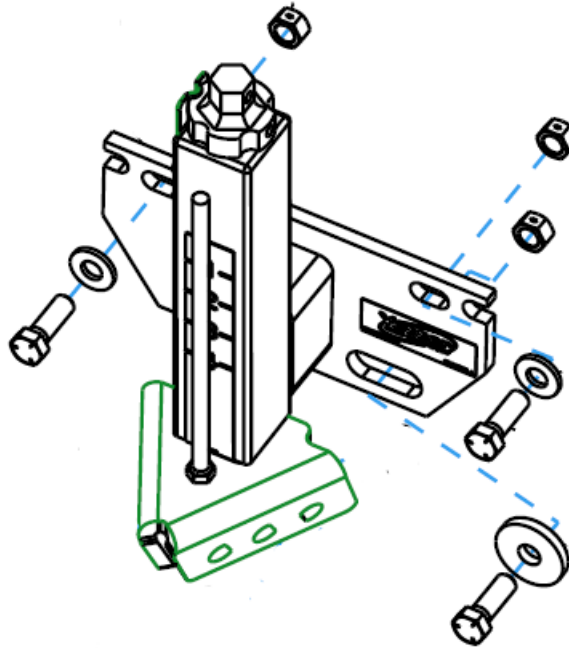

**STEP 3.** Align the residue wheels to the planter opener blades. The residue manager mount bracket has slotted holes in the faceplate to move the residue manager wheels side to side; to be able to center the wheels on the furrow. Fully tighten mounting bolts. Torque to 85 ft. lbs.

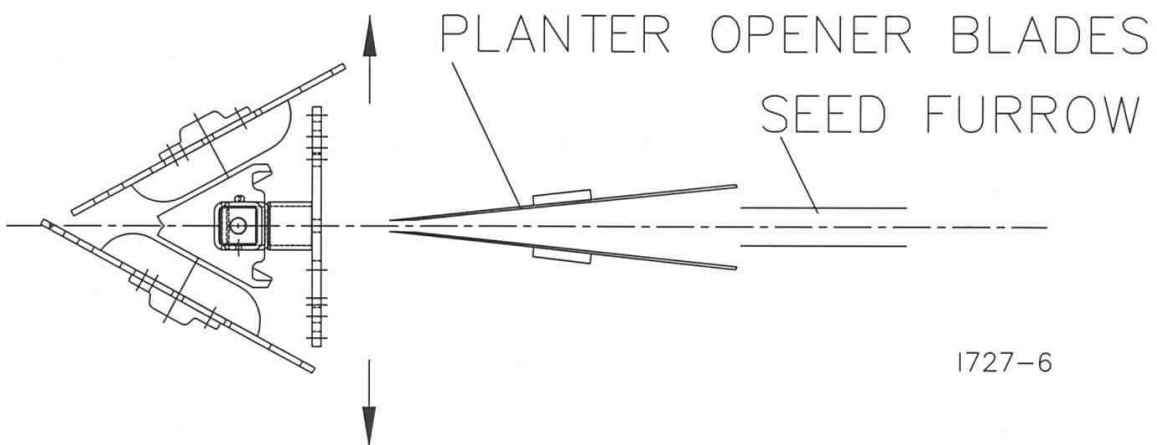

## MAINTENANCE

After a few hours use, check all bolts to make sure they are tight.

**STEP 1.** Regularly inspect the residue manager for loose or worn bolts. Repair and replace as needed. Use “BLUE” thread lock (removable) if bolts that secure the detent plate become loose from vibration.

**STEP 2.** Lubricate the screw adjust using #2 multi-purpose polyurea grease every 50 hours.

### Lubrication



**CAUTION:** To help prevent serious injury or death to you or others caused by unexpected movement, service machine on a level surface. Lower machine to ground or sufficiently lock or block raised machine before servicing. If machine is connected to tractor, engage parking brake and place transmission in "PARK", shut off engine and remove key. If machine is detached from tractor, block wheels and use shop stands to prevent movement.



**CAUTION:** Do not clean, lubricate, or adjust machine while in motion.

Use grease based on NLGI consistency numbers and the expected air temperature range during the service interval.

Use a **multi-purpose polyurea, water resistant, moderate speed, and NLGI grade #2** grease.

Other greases may be used if they meet the following **NLGI Performance**



**NOTICE:** Some types of grease thickener are not compatible with others. Consult your grease supplier before mixing different types of grease.

### Alternative Lubricants

Conditions in certain geographical areas may require special lubricants and lubrication practices which do not appear in the operator's manual. If there are any questions, consult Yetter Manufacturing Co. to obtain latest information and recommendation.

### Storing Lubricants

Your machine can operate at top efficiency only if clean lubricants are used.

Use clean containers to handle all lubricants.

Store them in an area protected from dust, moisture and other contaminants.

# MAINTENANCE

## Lubrication Symbols



Lubricate with grease at hourly interval indicated on symbol.

## Lubrication Intervals



**NOTICE: The recommended service intervals are based on normal conditions; severe or unusual conditions may require more frequent lubrication.**

Perform each lubrication and service procedure at the beginning and end of each season.

Clean grease fittings before using grease gun, to avoid injecting dirt and grit into the bearing. Replace any lost or broken fittings immediately. If a fitting fails to take grease, remove and clean thoroughly, replace fitting if necessary. Also check for failure of adjoining parts.

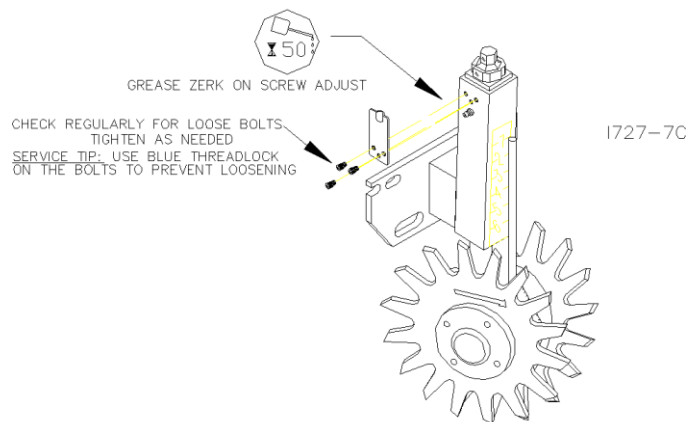

## Storing the Equipment

Store the machine in an area away from human activity

Store machine in RAISED position.

Install service locks on all wheel cylinders.

At the end of the season, the machine should be thoroughly inspected and prepared for storage. Repair or replace any worn or damaged components to prevent down time at the start of the next season. Store machine under cover with all parts in operating condition.

- Clean machine thoroughly to remove all dirt, debris and crop residue, which would hold moisture and cause rusting.
- Inspect machine for worn or broken parts. See your Yetter Farm Equipment dealer during the off-season so that parts or service can be acquired when machine is not needed in the field.
- Lubricate bearings as outlined in the Lubrication section
- Paint all parts which are chipped or worn and require repainting.
- Store machine in a clean, dry place with the planting unit out of the sun.
- If the machine cannot be stored inside, cover with a waterproof tarpaulin and tie securely in place.
- Do not allow children to play on or around the machine

# PARTS IDENTIFICATION

## 2966-107

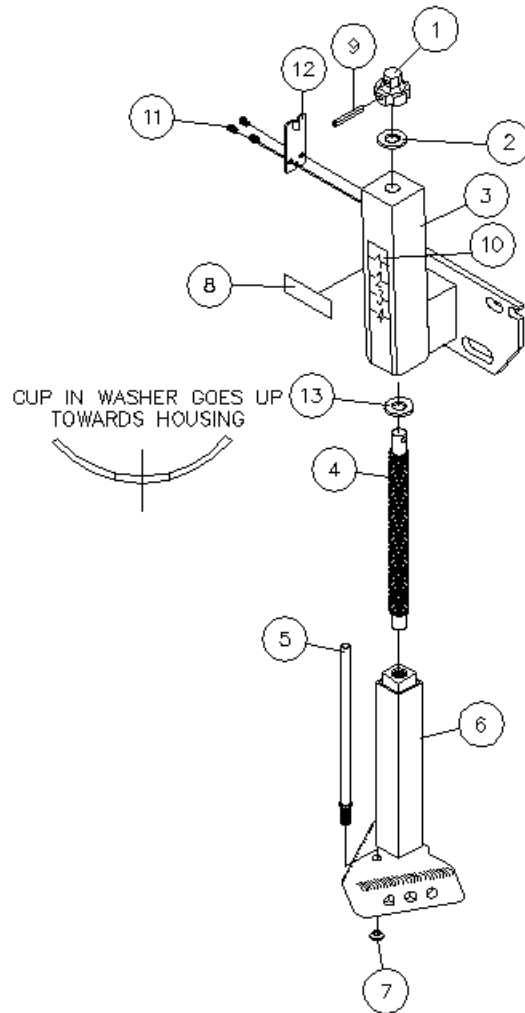

13	1	2526-456	BVLE DISC SPRG .630 IDX 1.250D
12	1	2967-652	DETENT PLATE
11	3	2510-102	#10-32 X .31 HEX SOCKET HD ZYD.
10	1	2565-815	ADJUSTMENT DECAL
9	1	2530-158	PIN,COILED SPRING,1/4X1-1/2,HD
8	1	2565-179	YETTER DECAL 1" X 3"
7	1	2520-253	3/8-16 JAM HEX NUT ZP
6	1	2966-206	ADJUSTMENT STEM W.A.
5	1	2967-755	INDICATOR ROD, 9"
4	1	2967-657	ACME SCREW
3	1	2966-204	HOUSING W.A.
2	1	2526-453	5/8 SAE FLATWASHER ZP
1	1	2967-699	ADJUSTMENT KNOB (9/07)
DET	QTY	PART NO.	DESCRIPTION

# PARTS IDENTIFICATION

## 2966-109

### CNH

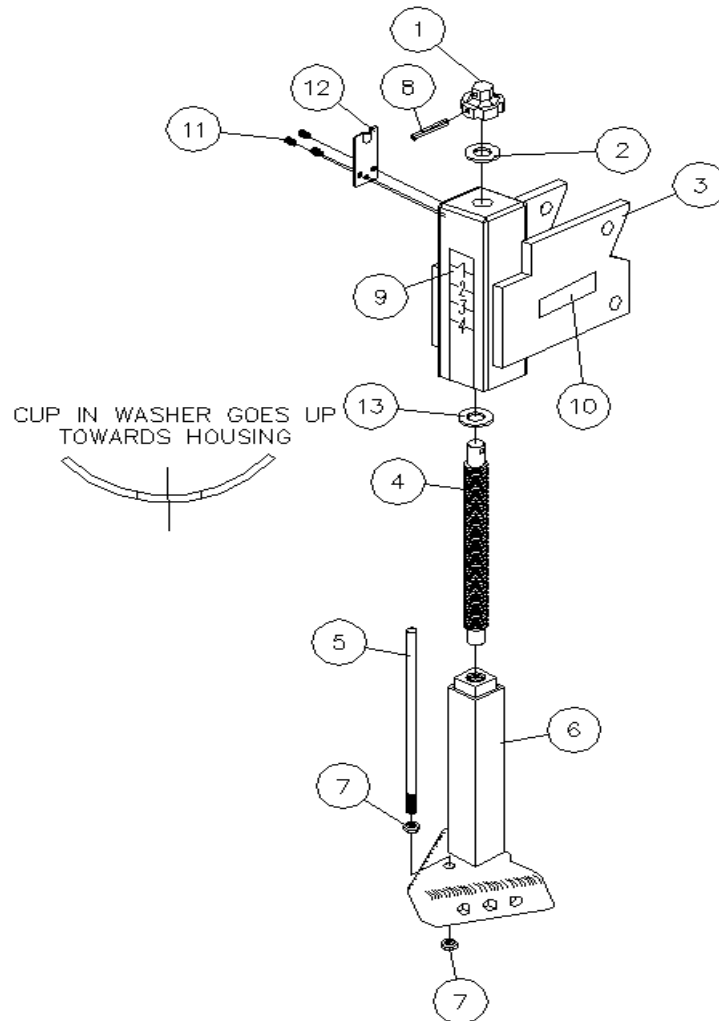

13	1	2526-456	BVLE DISC SPRG .630 IDX 1.250D
12	1	2967-652	DETENT PLATE
11	3	2510-102	#10-32 X .25 HEX SOCKET HD ZYD.
10	2	2565-179	YETTER DECAL, 1 X 3
9	1	2565-815	ADJUSTMENT DECAL
8	1	2530-158	PIN,COILED SPRING,1/4X1-1/2,HD
7	2	2520-253	3/8-16 JAM HEX NUT ZP
6	1	2966-208	ADJUSTMENT STEM W.A. (CNH)
5	1	2967-661	INDICATOR ROD (CNH)
4	1	2967-665	ACME SCREW (CNH)
3	1	2966-207	HOUSING W.A.(CNH)
2	1	2526-453	5/8 SAE FLATWASHER ZP
1	1	2967-699	ADJUSTMENT KNOB (9/07)
DET	QTY	PART NO.	DESCRIPTION

# PARTS IDENTIFICATION

## 2966-112

### NARROW

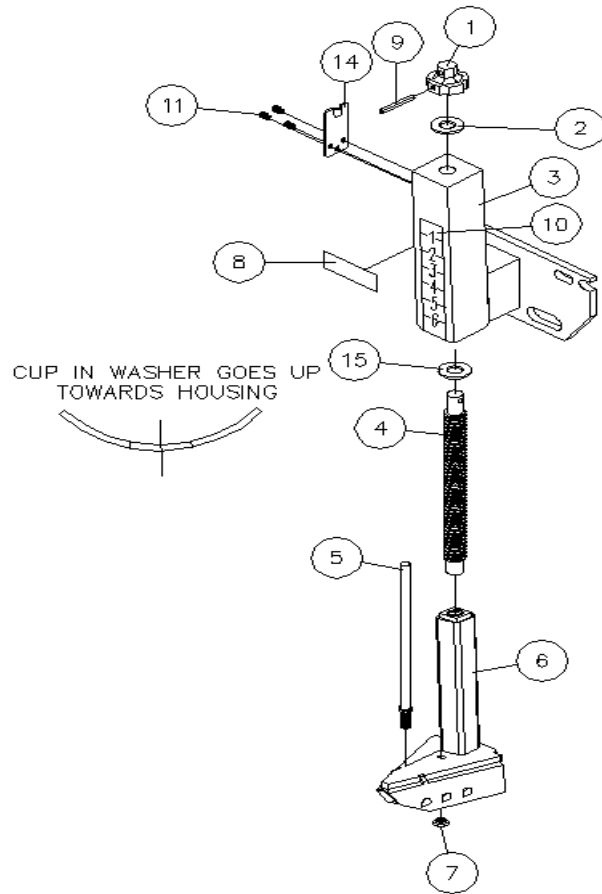

13	1	2526-456	BVLE DISC SPRG .630 IDX 1.250D
12	1	2967-652	DETENT PLATE
11	3	2510-102	#10-32 X .25 HEX SOCKET HD ZYD.
10	1	2565-815	ADJUSTMENT DECAL
9	1	2530-158	PIN,COILED SPRING,1/4X1-1/2,HD
8	1	2565-179	YETTER DECAL 1" X 3"
7	1	2520-253	3/8-16 JAM HEX NUT ZP
6	1	2966-211	NARROW ADJ. STEM W.A.
5	1	2967-755	INDICATOR ROD, 9"
4	1	2967-657	ACME SCREW
3	1	2966-204	HOUSING W.A.
2	1	2526-453	5/8 SAE FLATWASHER ZP
1	1	2967-699	ADJUSTMENT KNOB (9/07)
DET	QTY	PART NO.	DESCRIPTION



# PARTS IDENTIFICATION

## 2966-114

### NARROW (LONG ARM)

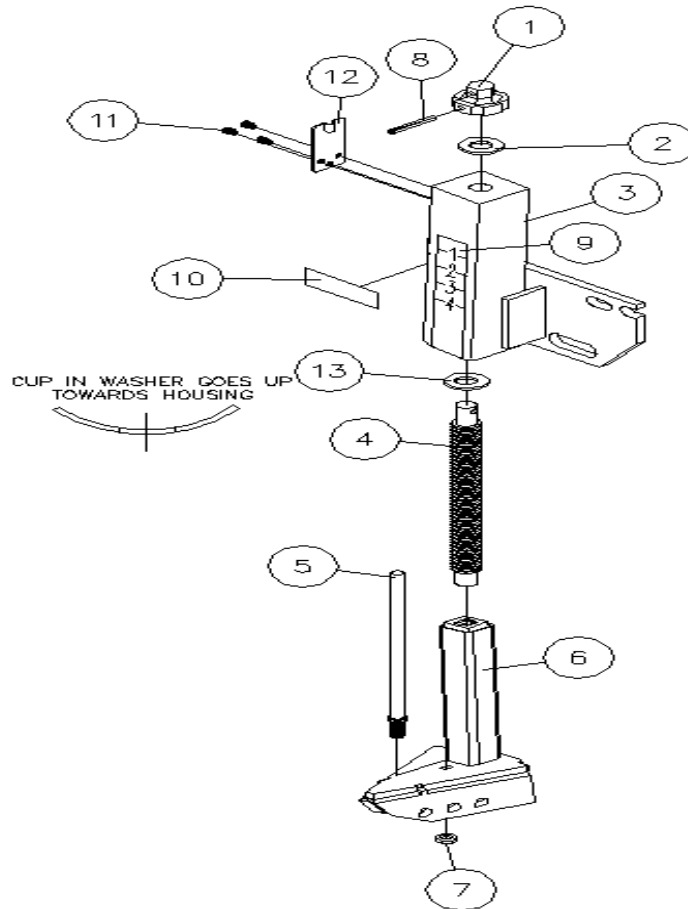

13	1	2526-456	BVLE DISC SPRG .630 IDX 1.250D
12	1	2967-652	DETENT PLATE
11	3	2510-102	#10-32 X .25 HEX SOCKET HD ZYD.
10	1	2565-179	YETTER DECAL 1" X 3"
9	1	2565-815	ADJUSTMENT DECAL
8	1	2530-158	PIN, COILED SPRING, 1/4X1-1/2, HD
7	1	2520-253	3/8-16 JAM HEX NUT ZP
6	1	2966-211	NARROW ADJ. STEM W.A.
5	1	2967-755	INDICATOR ROD, 9"
4	1	2967-657	ACME SCREW
3	1	2966-212	HOUSING W.A., LONG ARM
2	1	2526-453	5/8 SAE FLATWASHER ZP
1	1	2967-699	ADJUSTMENT KNOB (9/07)
DET	QTY	PART NO.	DESCRIPTION

# PARTS IDENTIFICATION

## 2966-115 (LONG ARM)

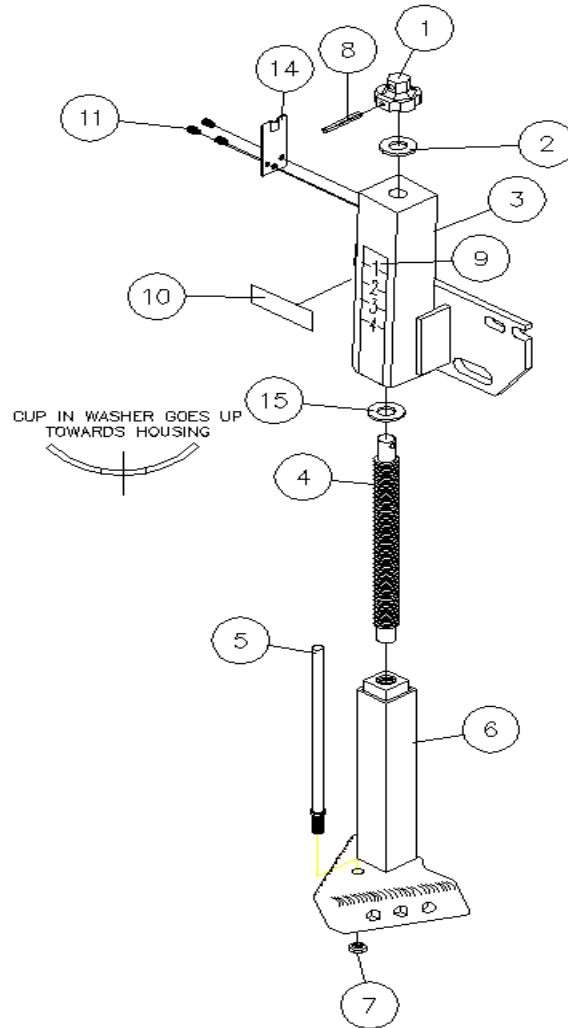

13	1	2526-456	BVLE DISC SPRG .630 IDX 1.250D
12	1	2967-652	DETENT PLATE
11	3	2510-102	#10-32 X .25 HEX SOCKET HD ZYD.
10	1	2565-179	YETTER DECAL 1" X 3"
9	1	2565-815	ADJUSTMENT DECAL
8	1	2530-158	PIN,COILED SPRING,1/4X1-1/2,HD
7	1	2520-253	3/8-16 JAM HEX NUT ZP
6	1	2966-206	ADJUSTMENT STEM W.A.
5	1	2967-755	INDICATOR ROD, 9"
4	1	2967-657	ACME SCREW
3	1	2966-212	HOUSING W.A., LONG ARM
2	1	2526-453	5/8 SAE FLATWASHER ZP
1	1	2967-699	ADJUSTMENT KNOB (9/07)
DET	QTY	PART NO.	DESCRIPTION

# PARTS IDENTIFICATION

## 2966-127

### WHITE 8000

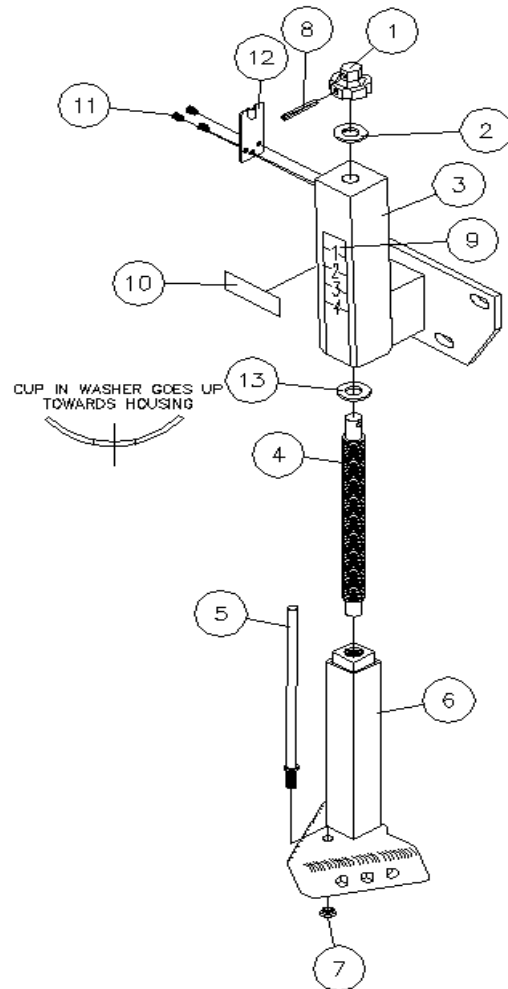

13	1	2526-456	BVLE DISC SPRG .630 IDX 1.250D
12	1	2967-652	DETENT PLATE
11	3	2510-102	#10-32 X .25 HEX SOCKET HD ZYD.
10	1	2565-179	YETTER DECAL 1" X 3"
9	1	2565-815	ADJUSTMENT DECAL
8	1	2530-158	PIN,COILED SPRING,1/4X1-1/2,HD
7	1	2520-253	3/8-16 JAM HEX NUT ZP
6	1	2966-206	ADJUSTMENT STEM W.A.
5	1	2967-755	INDICATOR ROD, 9"
4	1	2967-657	ACME SCREW
3	1	2966-213	HOUSING W.A., WHITE
2	1	2526-453	5/8 SAE FLATWASHER ZP
1	1	2967-699	ADJUSTMENT KNOB (9/07)
DET	QTY	PART NO.	DESCRIPTION

## PARTS IDENTIFICATION 2967-052A-ST

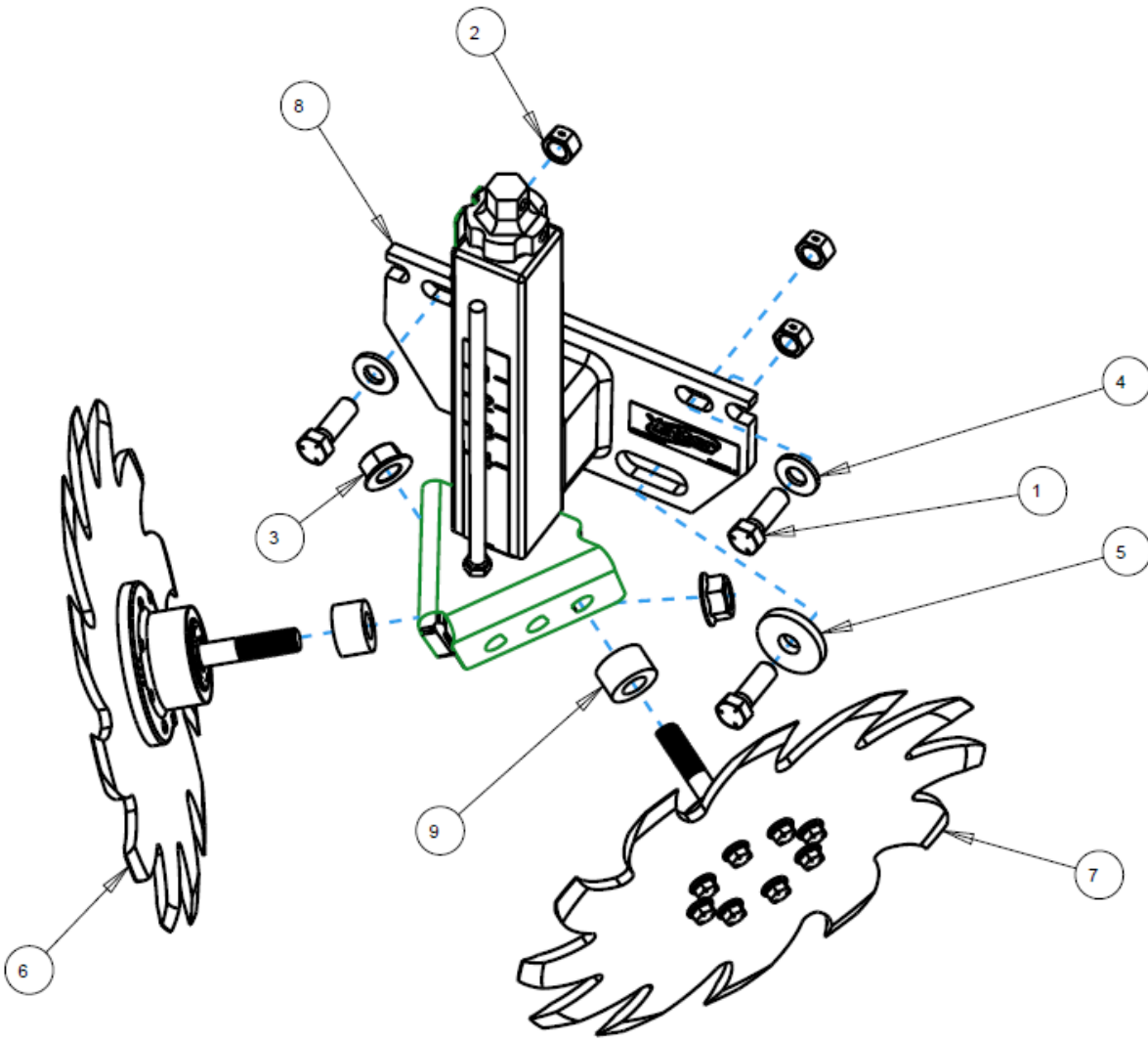

ITEM	PART NO.	DESCRIPTION	QTY
1	2502-294	1/2-13 X 1-1/2 HHCS GRADE 5	3
2	2520-357	1/2-13 LOCK HEX NUT GRADE A	3
3	2520-465	5/8-11 FLANGE NUT GRADE 8	2
4	2526-355	1/2 FLAT WASHER HARDENED	2
5	2526-402	9/16 ID X 1-3/4 OD X 1/4 THICK MACHINE WASHER	1
6	2966-102-ST	SHARK TOOTH WHEEL ASSEMBLY RIGHT HAND	1
7	2966-103-ST	SHARK TOOTH WHEEL ASSEMBLY LEFT HAND	1
8	2966-107	SCREW ADJUST ASSEMBLY	1
9	2967-302	SPACER 3/4"	2

# PARTS IDENTIFICATION 2967-053A-ST

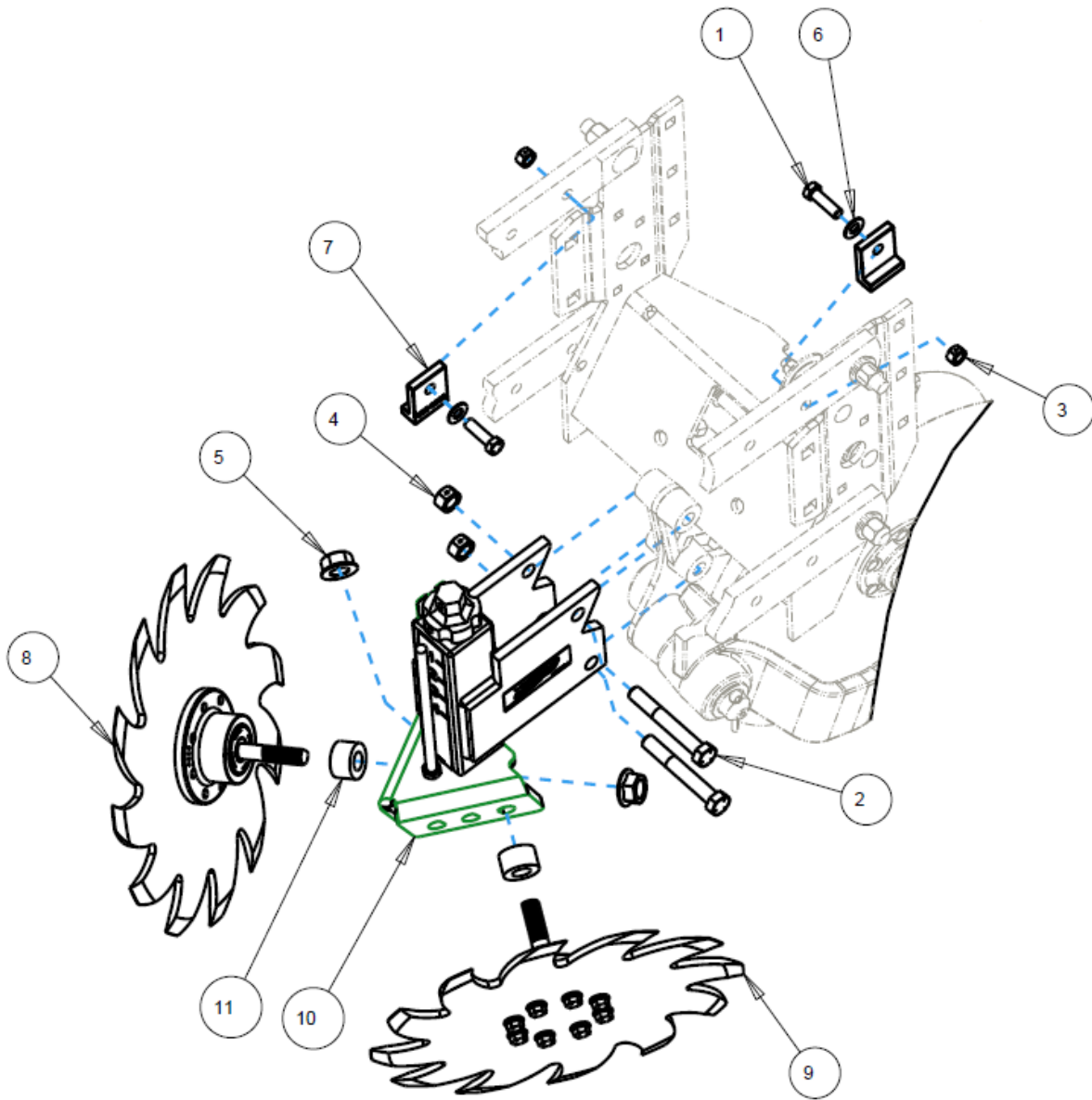

ITEM	PART NO.	DESCRIPTION	QTY
1	2502-244	3/8-16 X 1-1/4 HHCS GRADE 5	2
2	2502-316	1/2-13 X 3-1/2 HHCS GRADE 5	2
3	2520-255	3/8-16 LOCK HEX NUT GRADE A	2
4	2520-357	1/2-13 LOCK HEX NUT GRADE A	2
5	2520-465	5/8-11 FLANGE NUT GRADE 8	2
6	2526-253	3/8 SAE FLAT WASHER	2
7	2960-223	ARM STOP	2
8	2966-102-ST	SHARK TOOTH WHEEL ASSEMBLY RIGHT HAND	1
9	2966-103-ST	SHARK TOOTH WHEEL ASSEMBLY LEFT HAND	1
10	2966-109	SCREW ADJUST ASSEMBLY CASEIH	1
11	2967-302	SPACER 3/4"	2

# PARTS IDENTIFICATION

## 2967-054A-BW

### NARROW ROW

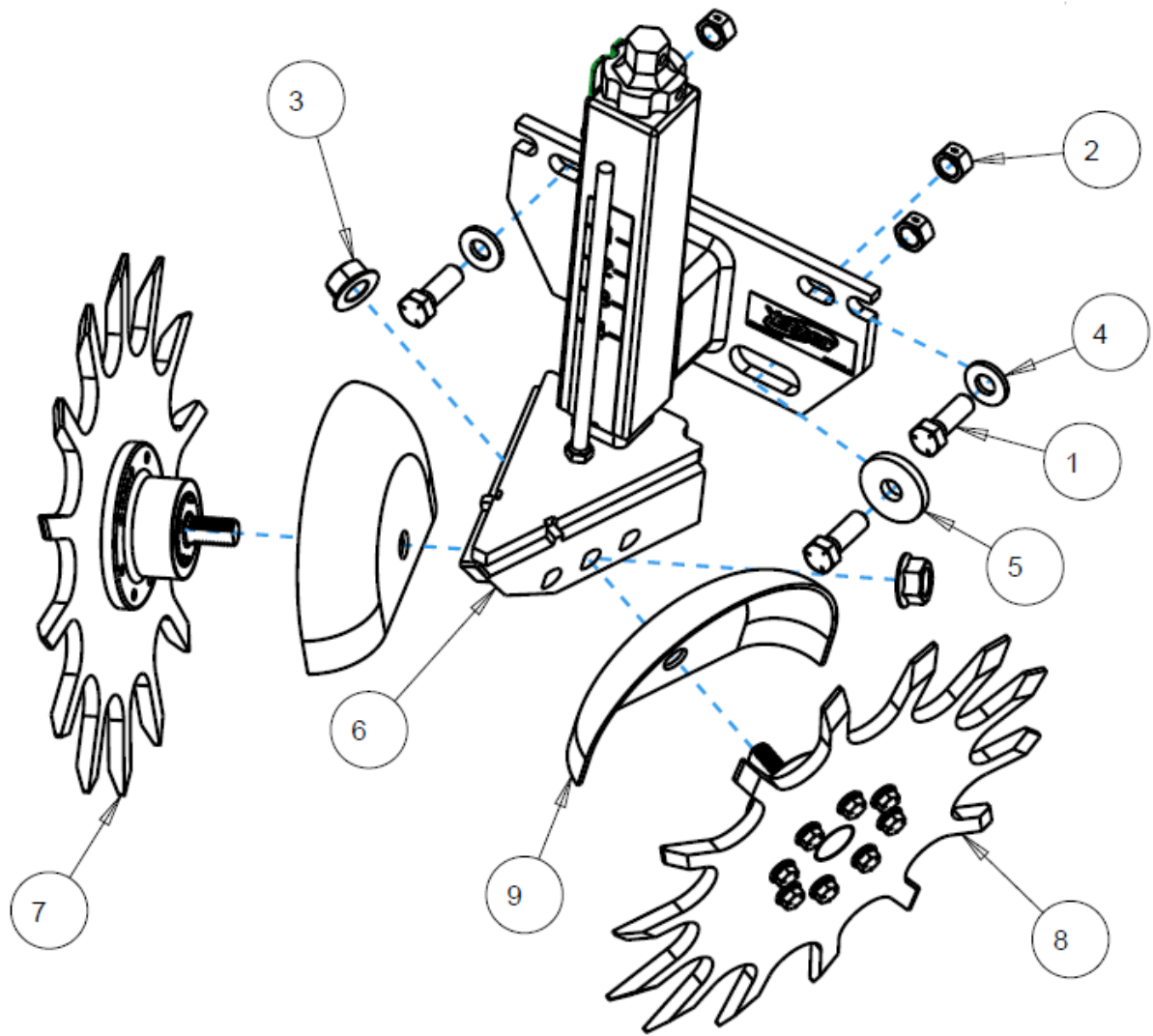

ITEM	PART NO.	DESCRIPTION	QTY
1	2502-294	1/2-13 X 1-1/2 HHCS GRADE 5	3
2	2520-357	1/2-13 LOCK HEX NUT GRADE A	3
3	2520-465	5/8-11 FLANGE NUT GRADE 8	2
4	2526-355	1/2 FLAT WASHER HARDENED	2
5	2526-402	9/16 ID X 1-3/4 OD X 1/4 THICK MACHINE WASHER	1
6	2966-112	NARROW SCREW ADJUST ASSEMBLY	1
7	2966-116-BW	NR BEVELED WHEEL ASSEMBLY RIGHT HAND	1
8	2966-117-BW	NR BEVELED WHEEL ASSEMBLY LEFT HAND	1
9	2967-392	SHIELD	2

**PARTS IDENTIFICATION**  
**2967-056A**  
**NARROW ROW (LONG PARALLEL ARM)**

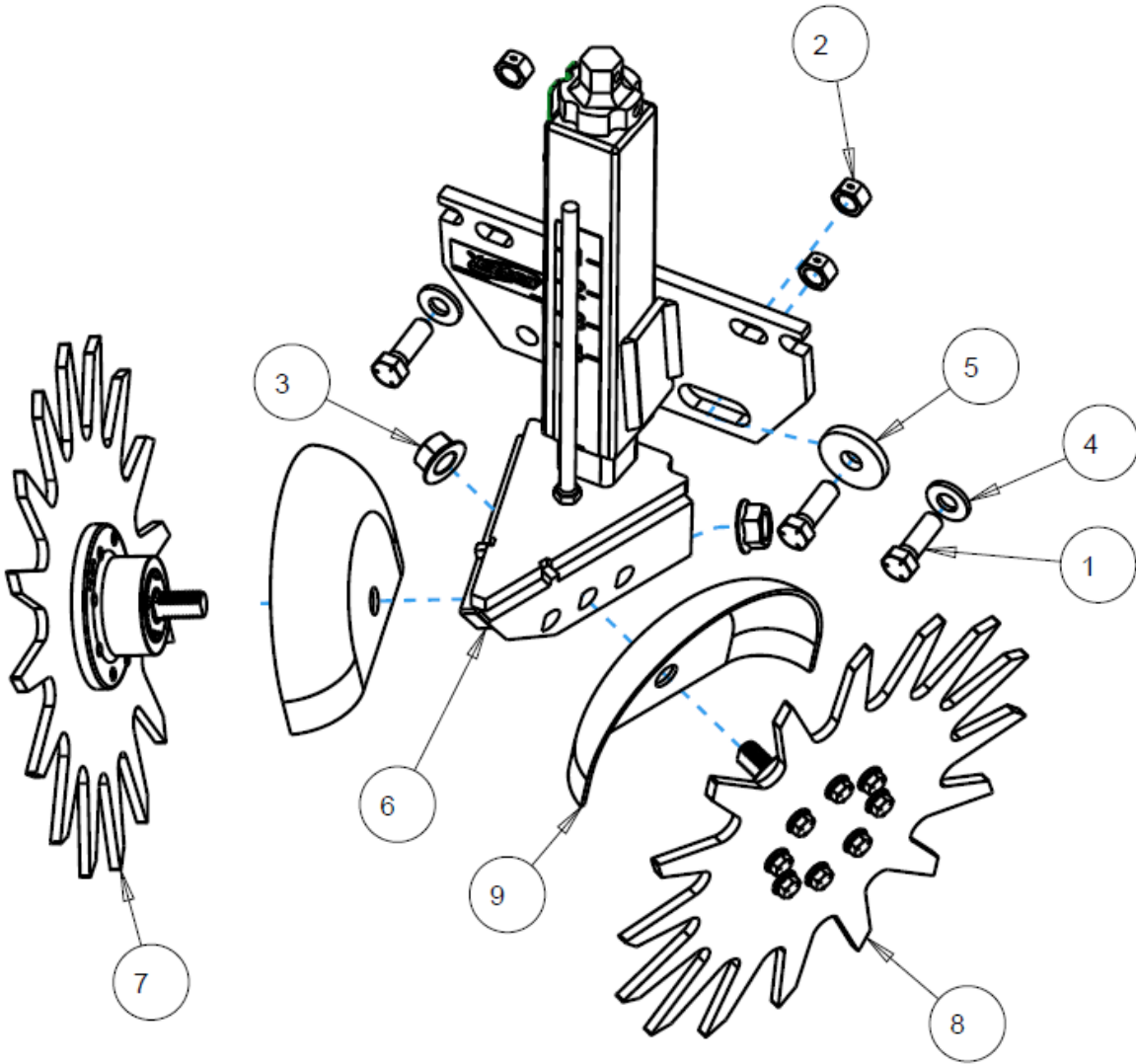

ITEM	PART NO.	DESCRIPTION	QTY
1	2502-294	1/2-13 X 1-1/2 HHCS GRADE 5	3
2	2520-357	1/2-13 LOCK HEX NUT GRADE A	3
3	2520-465	5/8-11 FLANGE NUT GRADE 8	2
4	2526-355	1/2 FLAT WASHER HARDENED	2
5	2526-402	9/16 ID X 1-3/4 OD X 1/4 THICK MACHINE WASHER	1
6	2966-114	NARROW SCREW ADJUST ASSEMBLY LONG ARM	1
7	2966-116	NR SPOKE WHEEL ASSEMBLY RIGHT HAND	1
8	2966-117	NR SPOKE WHEEL ASSEMBLY LEFT HAND	1
9	2967-392	SHIELD	2

## PARTS IDENTIFICATION 2967-057A-ST (LONG PARALLEL ARM)

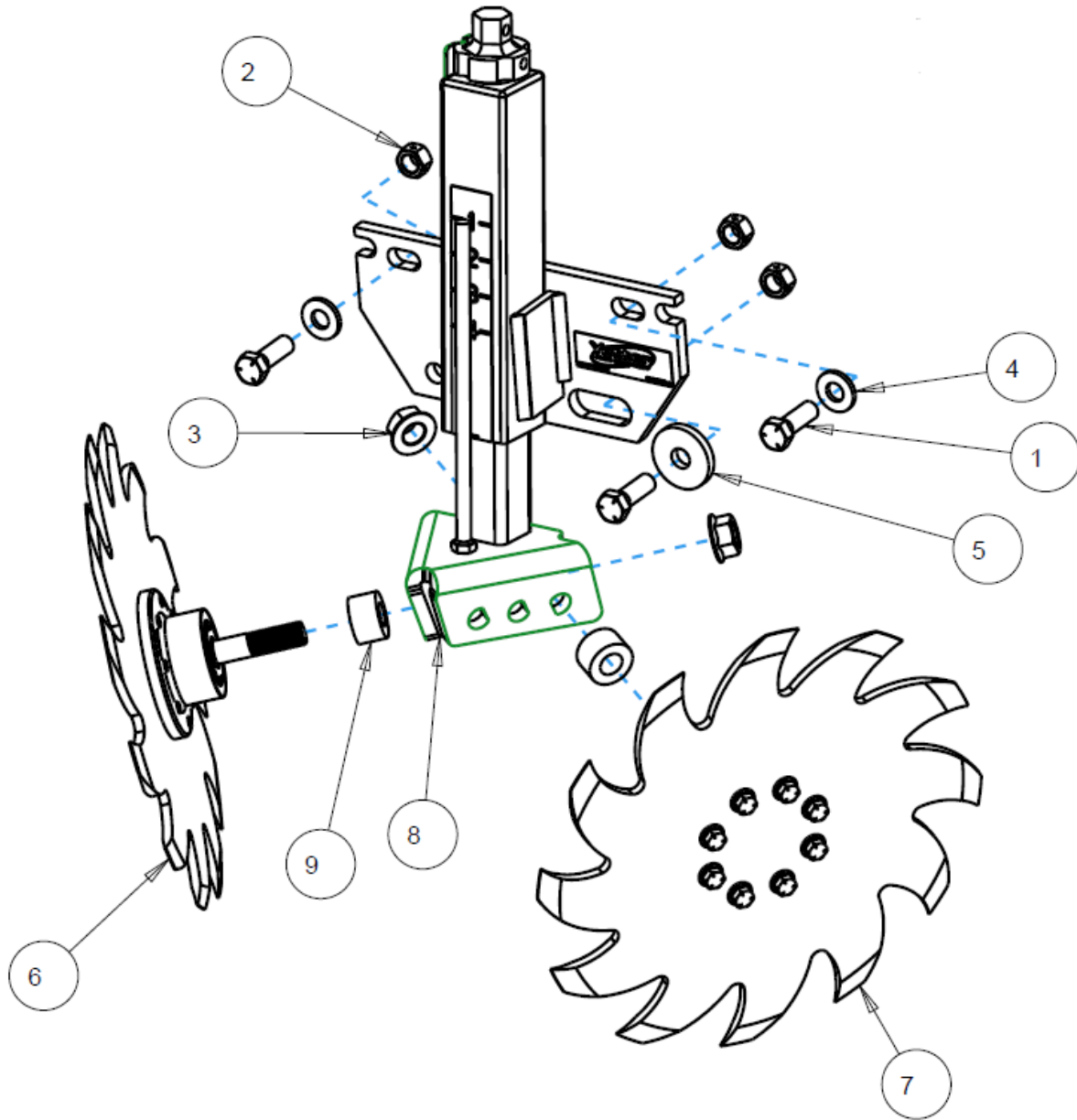

ITEM	PART NO.	DESCRIPTION	QTY
1	2502-294	½-13 X 1-1/2 HHCS GRADE 5	3
2	2520-357	½-13 LOCK HEX NUT GRADE A	3
3	2520-465	5/8-11 FLANGE NUT GRADE 8	2
4	2526-355	½ FLAT WASHER HARDENED	2
5	2526-402	9/16 ID X 1-3/4 OD X ¼ THICK MACHINE WASHER	1
6	2966-102-ST	SHARK TOOTH WHEEL ASSEMBLY RIGHT HAND	1
7	2966-103-ST	SHARK TOOTH WHEEL ASSEMBLY LEFT HAND	1
8	2966-115	SCREW ADJUST ASSEMBLY LONG PARALLEL ARM	1
9	2967-302	SPACER ¾"	2



**PARTS IDENTIFICATION**  
**2967-058A-BW**  
**WHITE 8000**

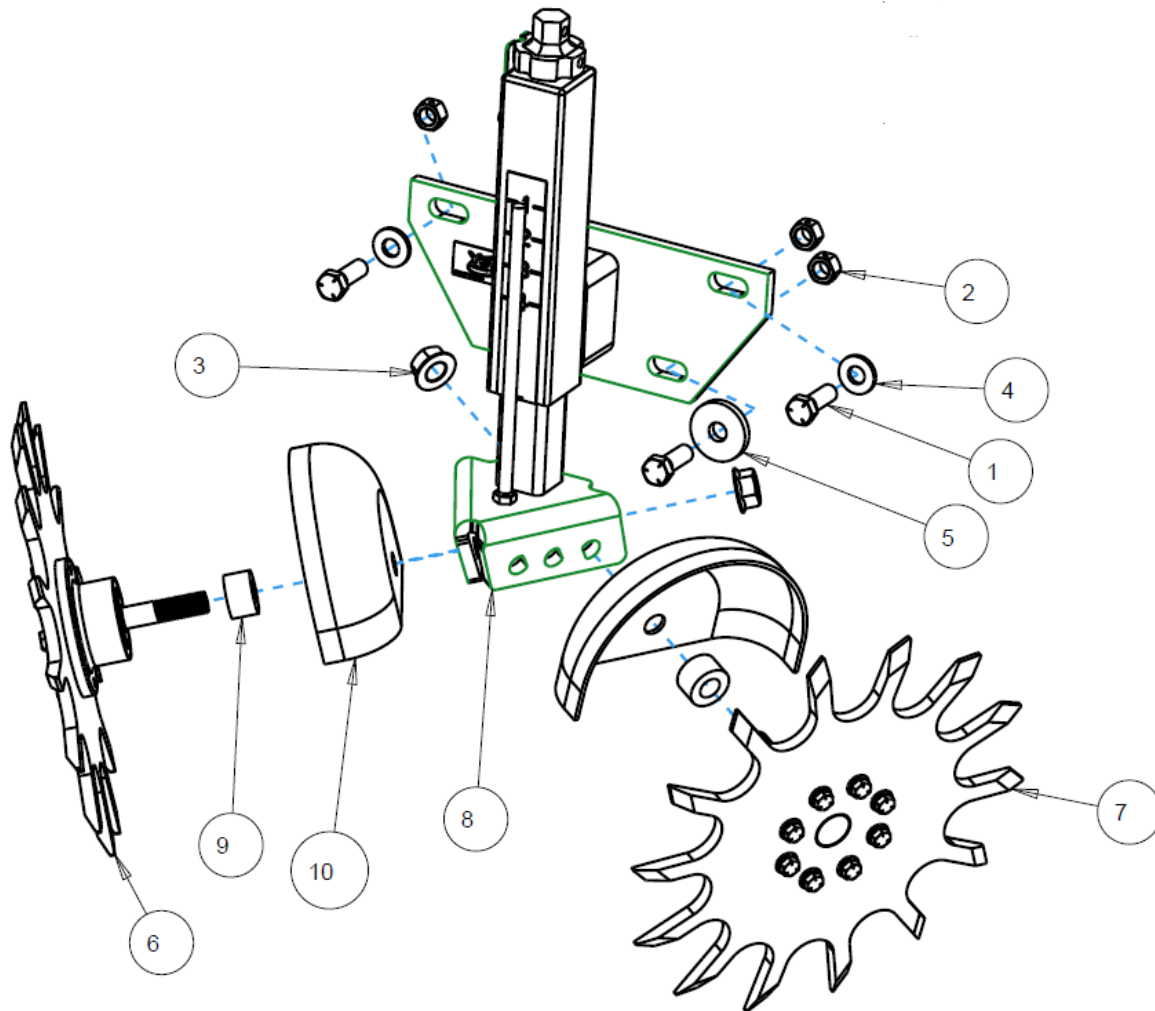

ITEM	PART NO.	DESCRIPTION	QTY
1	2502-294	1/2-13 X 1-1/2 HHCS GRADE 5	3
2	2520-357	1/2-13 LOCK HEX NUT GRADE A	3
3	2520-465	5/8-11 FLANGE NUT GRADE 8	2
4	2526-355	1/2 FLAT WASHER HARDENED	2
5	2526-402	9/16 ID X 1-3/4 OD X 1/4 THICK MACHINE WASHER	1
6	2966-102-BW	BEVELED WHEEL ASSEMBLY RIGHT HAND	1
7	2966-103-BW	BEVELED WHEEL ASSEMBLY LEFT HAND	1
8	2966-127	SCREW ADJUST ASSEMBLY WHITE 8000	1
9	2967-302	SPACER 3/4"	2
10	2967-336	SHIELD	2

**PARTS IDENTIFICATION**  
**2966-102 RIGHT HAND SPOKE WHEEL (SHOWN)**  
**2966-103 LEFT HAND SPOKE WHEEL**

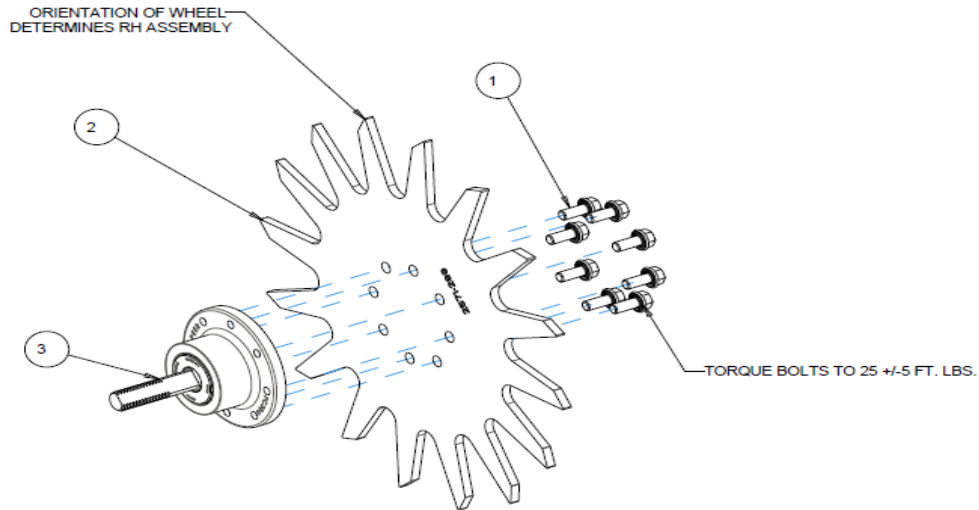

ITEM	PART NO.	DESCRIPTION	QTY
1	2502-220	5/16-18 X 3/4 HHFS GR5 ZP	8
2	2571-289	13" TAPER TOOTH SPOKE WHEEL, 8 BOLT	1
3	2965-501	HUB ASSEMBLY, 2.406 SPINDLE	1

**2966-102-BW RIGHT HAND BEVELED WHEEL (SHOWN)**  
**2966-103-BW LEFT HAND BEVELED WHEEL**

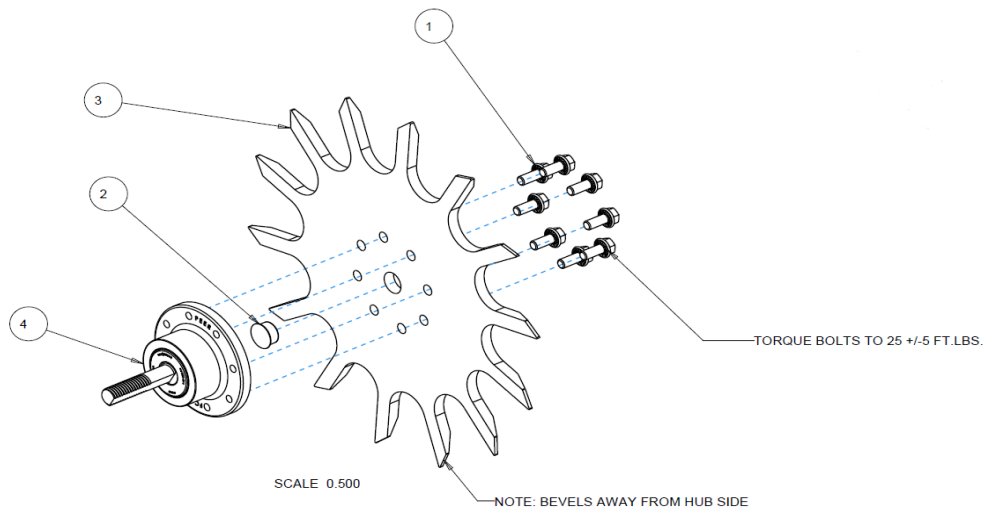

ITEM	PART NO.	DESCRIPTION	QTY
1	2502-220	5/16-18 X 3/4 HHFS GR5 ZP	8
2	2570-994	BEVEL WHEEL CENTER HOLE PLUG	1
3	2571-287-R	13" BEVEL WHEEL, 8 BOLT, RH	1
4	2965-501	HUB ASSEMBLY, 2.406 SPINDLE	1

**PARTS IDENTIFICATION**  
**2966-102-ST RIGHT HAND SHARK WHEEL (SHOWN)**  
**2966-103-ST LEFT HAND SHARK WHEEL**

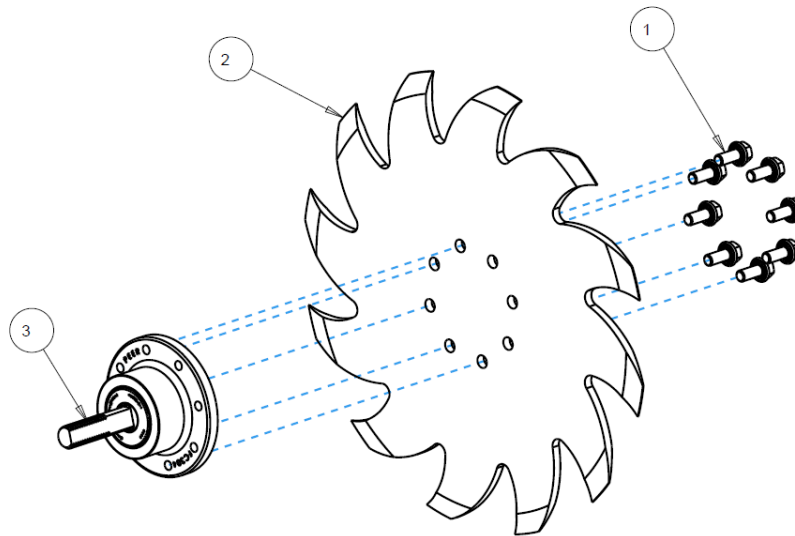

ITEM	PART NO.	DESCRIPTION	QTY
1	2502-220	5/16-18 X 3/4 HHFS GR5 ZP	8
2	2571-286	SHARKTOOTH WHEEL, 8 BOLT	1
3	2965-501	HUB ASSEMBLY, 2.406 SPINDLE	1

**2966-102-STF**  
**RIGHT HAND SHARKTOOTH FINGER WHEEL ASSEMBLY**

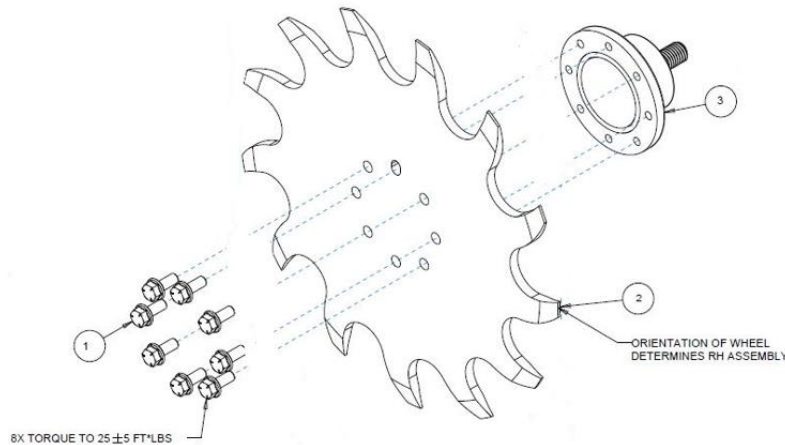

ITEM	QTY	PART NO.	DESCRIPTION
1	8	2502-220	5/16-18 X 3/4 HHFS BOLT GR5
2	1	2571-600	SHARKTOOTH FINGER WHEEL
3	1	2965-501	HUB ASSEMBLY 2.406" SPINDLE

## PARTS IDENTIFICATION

### 2966-117 LEFT HAND TAPER TOOTH WHEEL (SHOWN) 2966-116 RIGHT HAND TAPER TOOTH WHEEL

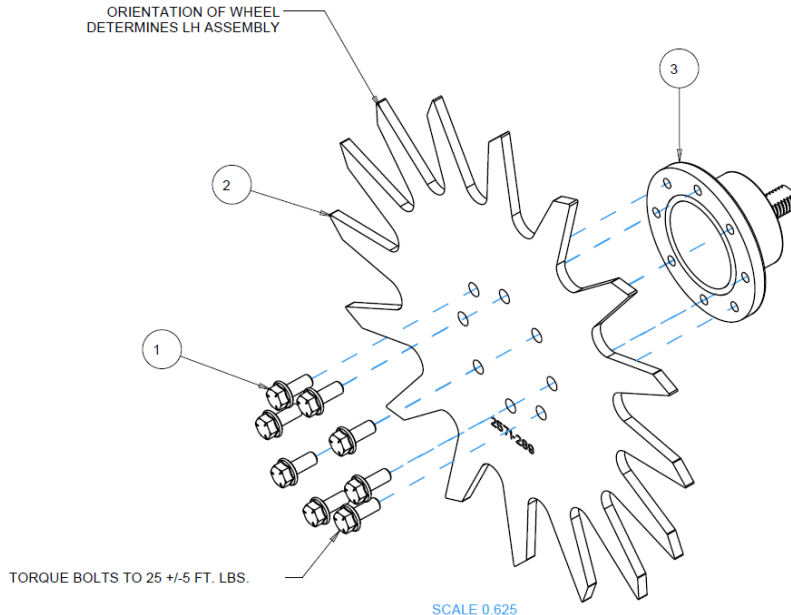

ITEM	PART NO.	DESCRIPTION	QTY
1	2502-220	5/16-18 X 3/4 HHFS GR5 ZP	8
2	2571-289	13" TAPER TOOTH SPOKE WHEEL, 8 BOLT	1
3	2965-502	HUB ASSEMBLY, 1.157 SPINDLE	1

### 2966-117-BW LEFT HAND BEVELED WHEEL (SHOWN) 2966-116-BW RIGHT HAND TAPER TOOTH WHEEL

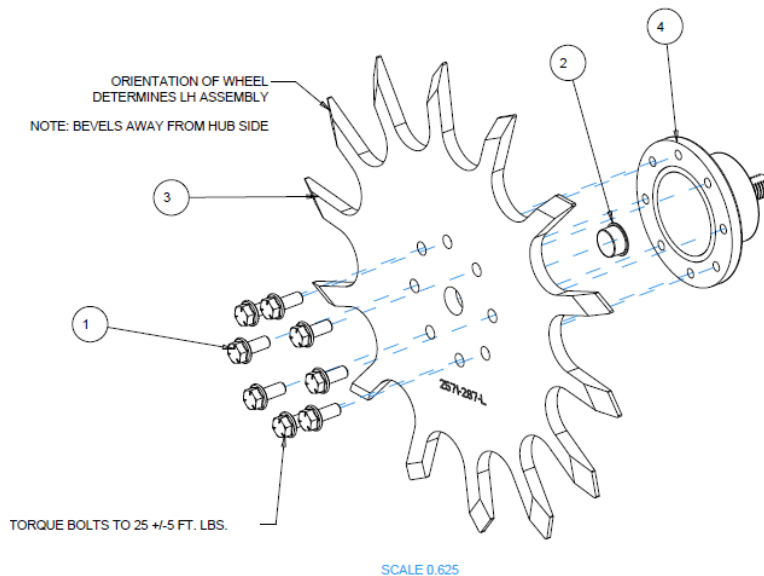

ITEM	PART NO.	DESCRIPTION	QTY
1	2502-220	5/16-18 X 3/4 HHFS GR5 ZP	8
2	2570-994	BEVEL WHEEL CENTER HOLE PLUG	1
3	2571-287-L	13" BEVEL WHEEL, 8 BOLT, LH	1
4	2965-502	HUB ASSEMBLY, 1.157 SPINDLE	1

## PARTS IDENTIFICATION

### 2966-116-ST RIGHT HAND SHARK TOOTH WHEEL (SHOWN) 2966-117-ST LEFT HAND SHARK TOOTH WHEEL

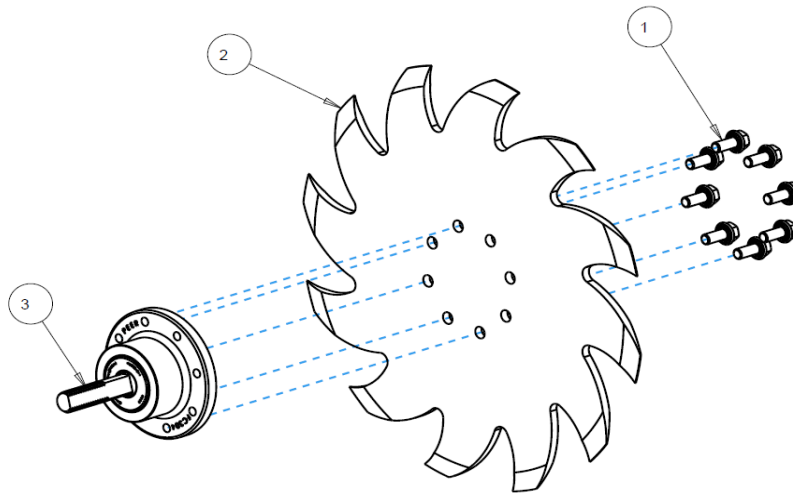

ITEM	PART NO.	DESCRIPTION	QTY
1	2502-220	5/16-18 X 3/4 HHFS GR5 ZP	8
2	2571-286	SHARKTOOTH WHEEL, 8 BOLT	1
3	2965-502	HUB ASSEMBLY, 1.157" SPINDLE	1

### 2966-116-ST RIGHT HAND SHARKTOOTH FINGER WHEEL

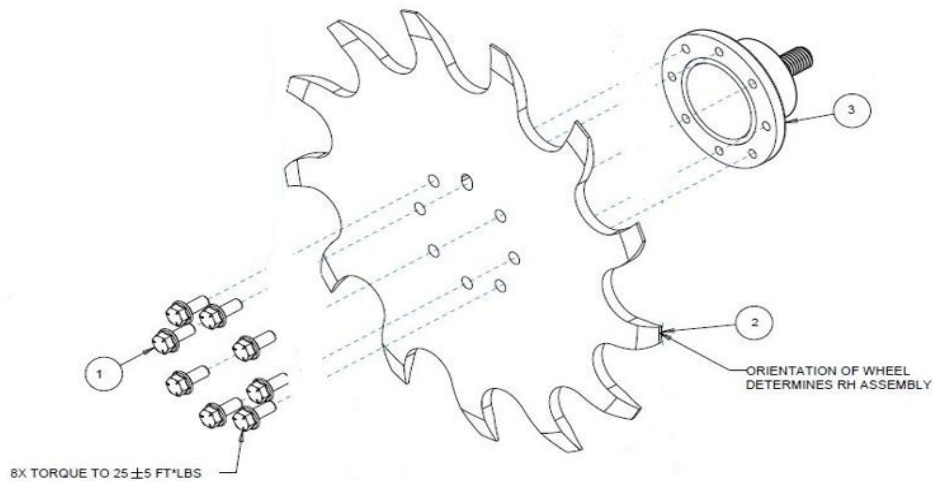

ITEM	QTY	PART NO.	DESCRIPTION
1	8	2502-220	5/16-18 X 3/4 HHFS BOLT GR5
2	1	2571-600	SHARKTOOTH FINGER WHEEL
3	1	2965-502	HUB ASSEMBLY 1.157" SPINDLE

## FIELD SERVICE KITS

2965-119 - SERVICE KIT FOR 2570-740-2.812 D-BOLT

2965-120 - SERVICE KIT FOR 2570-742-3.812 D-BOLT

2965-121 - SERVICE KIT FOR 2570-766-2.562 D-BOLT

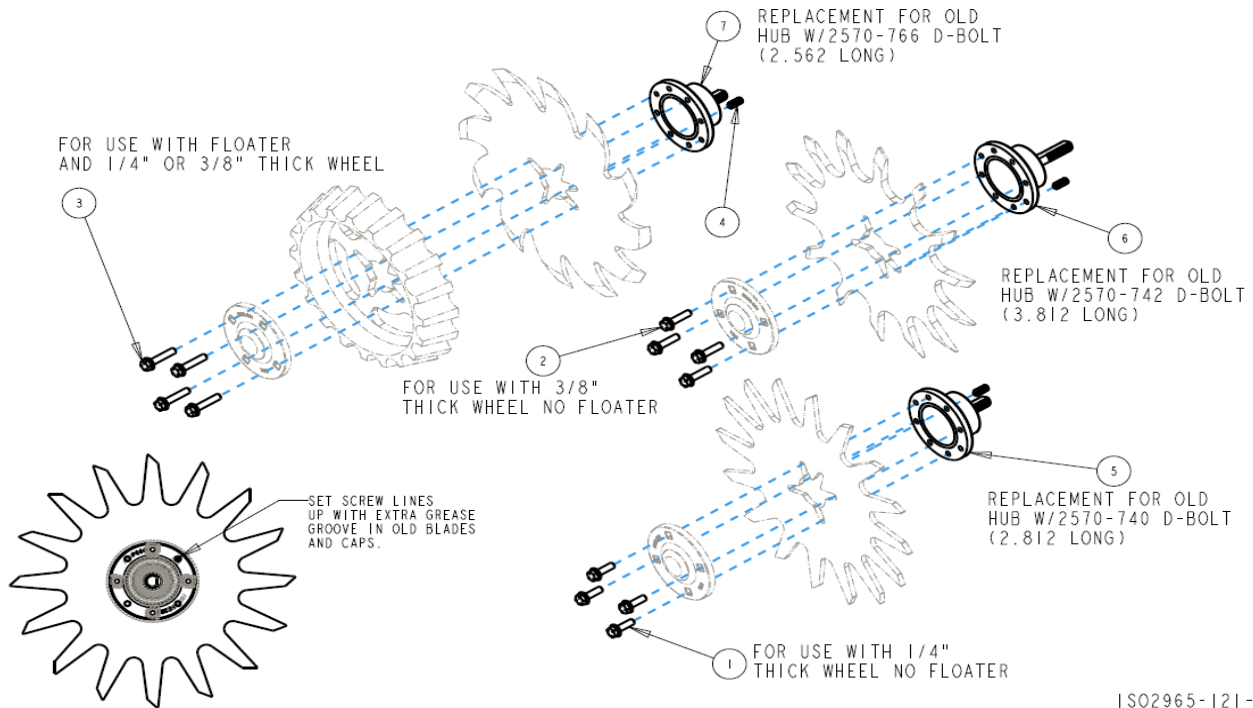

ISO2965-121-2

ITEM	PART NO	DESCRIPTION	QTY
1	2502-221	5/16-18 X 1 HHFS GRADE 5	4
2	2502-222	5/16-18 X 1-1/4 HHFS GRADE 5	4
3	2502-225	5/16-18 X 1-1/2 HHFS GRADE 5	4
4	2940-560	SET SCREW	1
5	2965-500	HUB ASSEMBLY 1.406 SPINDLE	1
6	2965-501	HUB ASSEMBLY 2.406 SPINDLE	1
7	2965-502	HUB ASSEMBLY 1.157 SPINDLE	1



ITEM	PART NO	DESCRIPTION	QTY
1	2505-207	5/16-18 X 1-1/4 CARRIAGE HEAD BOLT GRADE 5	4
2	2520-206	5/16-18 FLANGE LOCK NUT	4
3	2570-742	D-BOLT FLANGE HEAD 5/8-11 X 2.812 GRADE 8	1
4	2965-128	HUB/BEARING ASSEMBLY	1
	2550-069	SEAL	1
	2570-594	BEARING	1
	2570-715	INSERT	1
	2965-351	HUB	1
	2533-110	GREASE FITTING	1
5	2965-352	HUB CAP	1
6	2967-602	SHARK TOOTH WHEEL	1
7	2520-465	5/8-11 FLANGE LOCK NUT GRADE 8	1

## PARTS IDENTIFICATION

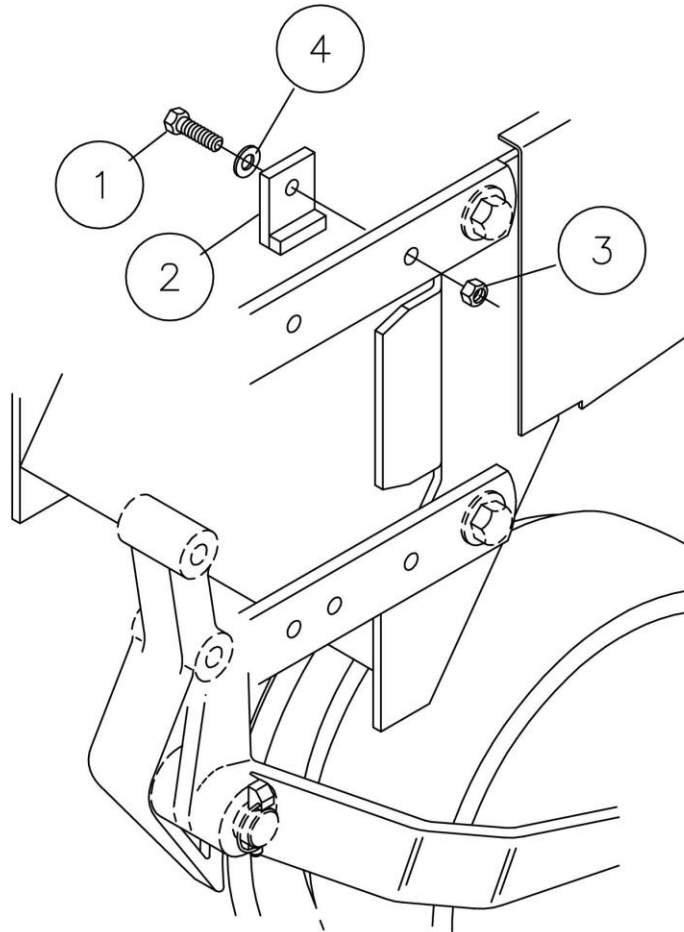

I727-4B

DET	QTY	PART NO.	DESCRIPTION
1	2	2502-244	3/8-16 X 1-1/4 HHCS GR 5
2	2	2960-223	CYCLO STOP
3	2	2520-255	3/8-16 HEX LOCK NUT
4	2	2526-253	3/8 SAE FLATWASHER



A Tradition of Solutions since 1930

Yetter Farm Equipment Co

PO BOX 358 109 S. McDonough

Colchester, IL 62326-0358

Phone: 309-776-4111

Toll Free: 800-447-5777

Email: [info@yetterco.com](mailto:info@yetterco.com)

For updated models and manuals visit the Yetter website:

[www.yetterco.com](http://www.yetterco.com)

© Yetter Farm Equipment Co. All Rights Reserved