

Yetter

FARM EQUIPMENT

Reveal Shark Tooth Conversion

2967-602-PP

OWNER'S MANUAL

PART IDENTIFICATION

2565-991 02/2025



YETTER MANUFACTURING CO.

Founded 1930

Colchester, IL 62326

Toll free: (800)447-5777.

Fax: (309)776-3222

Website: yetterco.com

E-mail: info@yetterco.com

YETTER

FOREWORD

You've just joined an exclusive but rapidly growing club.
For our part, we want to welcome you to the group and thank you for buying a Yetter product.

We hope your new Yetter products will help you achieve both goals-increase your productivity and increase your efficiency so that you may generate more profit.

This operator's manual has been designed into four major sections: Foreword, Safety Precautions, Installation Instructions and Parts Breakdown.

This **SAFETY ALERT SYMBOL** indicates important safety messages in the manual. When you see this symbol, be alert to the possibility of **PERSONAL INJURY** and carefully read the message that follows.

 **DANGER:** Indicates an imminently hazardous situation which, if not avoided "will" result in death or serious injury. This signal word is to be limited to the most extreme situations

 **WARNING:** Indicates a potentially hazardous situation which, if not avoided, "could" result in death or serious injury.

 **CAUTION:** Indicates a potentially hazardous situation, which if not avoided, "may" result in minor or moderate injury. It may also be used to alert against unsafe practices.

 **NOTICE:** Indicates information considered important, but not hazard related (e.g., messages relating to property damage).

It is the responsibility of the user to read the operator's manual and comply with the safe and correct operating procedure and to lubricate and maintain the product according to the maintenance schedule in the operator's manual.

The user is responsible for inspecting his machine and for having parts repaired or replaced when continued use of the product would cause damage or excessive wear to the other parts.

It is the user's responsibility to deliver his machine to the Yetter dealer who sold him the product for service or replacement of defective parts, which are covered by the warranty policy.

If you are unable to understand or follow the instructions provided in this publication, consult your local Yetter dealer or contact:

YETTER MANUFACTURING CO.

309/776-4111

800/447-5777

309/776-3222 (FAX)

Website: www.yetterco.com

E-mail: info@yetterco.com

WARRANTY POLICY

Yetter Manufacturing warrants all products manufactured and sold by it against defects in material. This warranty being expressly limited to replacement at the factory of such parts or products as will appear to be defective after inspection. This warranty does not obligate the Company to bear cost of labor in replacement of parts. It is the policy of the company to make improvements without incurring obligations to add them to any unit already sold. No warranty is made or authorized to be made, other than herein set forth. This warranty is in effect for one year after purchase.

Dealer : _____

Yetter Manufacturing warrants its own products only and cannot be responsible for damage to equipment on which mounted.



SAFETY PRECAUTIONS



A brief description of signal words that may be used in this manual:

DANGER: Indicates an imminently hazardous situation which, if not avoided, “will” result in death or serious injury. This signal word is to be limited to the most extreme situations.

WARNING: Indicates a potentially hazardous situation which, if not avoided, “could” result in death or serious injury.

CAUTION: Indicates a potentially hazardous situation, which if not avoided, “may” result in minor or moderate injury. It may also be used to alert against unsafe practices.

NOTICE: Indicates information considered important, but not hazard related (e.g., messages relating to property damage).

Consult your implement and tractor operator’s manual for correct and safe operating practices. Be aware of towed implement width and allow safe clearance.

Safety decals are placed on the implement to alert the operator and others to the risk of personal injury or unsafe operation during normal operations and servicing.

1. The safety decals must be kept clean and in good condition to ensure that they are legible.
2. Safety decals must be replaced if they are missing or illegible.
3. When components are replaced during repair or servicing, check that the new components include the necessary safety signs.
4. Replacement safety decals may be obtained from your local dealer.



WARNING

Read these instructions carefully to acquaint yourself with the Equipment. Working with unfamiliar equipment can lead to accidents.

Never park the equipment on a steep incline or leave the equipment running unattended.

Never clean, lubricate or adjust a machine that is in motion.

Always check that straps are secure.

Make sure latches are in pinned position when moving equipment.

Do not allow children to operate this equipment.

Do not allow riders on the equipment, trailer and/or pick-up.

Use speed and caution dictated by the terrain being traversed. Do not operate on any slope steep enough to cause tipping or loss of control.

Read and understand the operator’s manual and require all other persons who will operate the equipment to do the same.

If operating on public roadways, where legal, be certain all lighting is operating properly and observe all traffic laws.

Beware of increased stopping distances and control effort when operating with implements attached.

Be familiar with all controls and be prepared to stop equipment quickly in an emergency.

FAILURE TO HEED MAY RESULT IN PERSONAL INJURY OR DEATH.

TABLE OF CONTENTS

FOREWORD..... 2

SAFETY.....2-3

BOLT TORQUE..... 4

INSTALLATION..... 5

OPERATION..... 6

PARTS IDENTIFICATION..... 8-10

BOLT TORQUE





NOTICE: Over-tightening hardware can cause just as much damage as under-tightening. Tightening hardware beyond the recommended range can reduce its shock load capacity.

All hardware is either Grade 5 unless otherwise noted. Grade 5 cap screws are marked with three radial lines on the head. Grade 8 cap screws are marked with six radial lines on the head. If hardware must be replaced, be sure to replace it with hardware of equal size, strength and thread type. Refer to the torque values chart when tightening hardware.

The chart below is a guide for proper torque. Use it unless a specified torque is called out elsewhere in the manual. Torque is the force applied to the end of the handle or cheater bar, times the length of the handle or bar. Tightening hardware beyond the recommended range can reduce its shock load capacity.

Use a torque wrench wherever possible

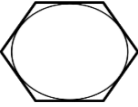
The following table shows torque in ft.-lbs. for coarse thread hardware.

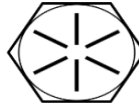
Bolt Diameter and Threads per Inch	 Grade 2	 Grade 5	 A-325	 Grade 8
1/4	6		10	14
5/16	12		20	30
3/8 – 16	25		35	50
7/16 – 14	35		55	80
1/2 – 13	55		85	125
9/16 – 12	75		125	175
5/8 – 11	105		170	235
3/4-10	185		305	425
7/8 – 9	170		445	690
1-8	260		670	1030
1 1/8 – 7	365		900	1460
1 1/4 - 7	515		1275	2060
1 3/8 – 6	675		1675	2700
1 1/2 - 6	900		2150	3500
1 3/4 – 5	1410		3500	5600

INSTALLATION INSTRUCTIONS

STEP 1: Remove the precision wheel assemble from the frame. Remove the hub/bearing from the wheel by taking the plow bolts off. Only the hub/bearing will be reused.

STEP 2: Using the provided carriage bolts assemble the Shark Tooth wheel to the precision hub. NOTE: use the 1" bolt for no floater wheel, and 1-3/4" bolt for use with a floater wheel. The Shark Tooth wheel is ambidextrous, and its assembly orientation will be determined by whether it is a left hand or right hand wheel assembly. The teeth should be back swept as the wheel enters and exits the soil.

ASSEMBLY WITHOUT FLOATER WHEEL

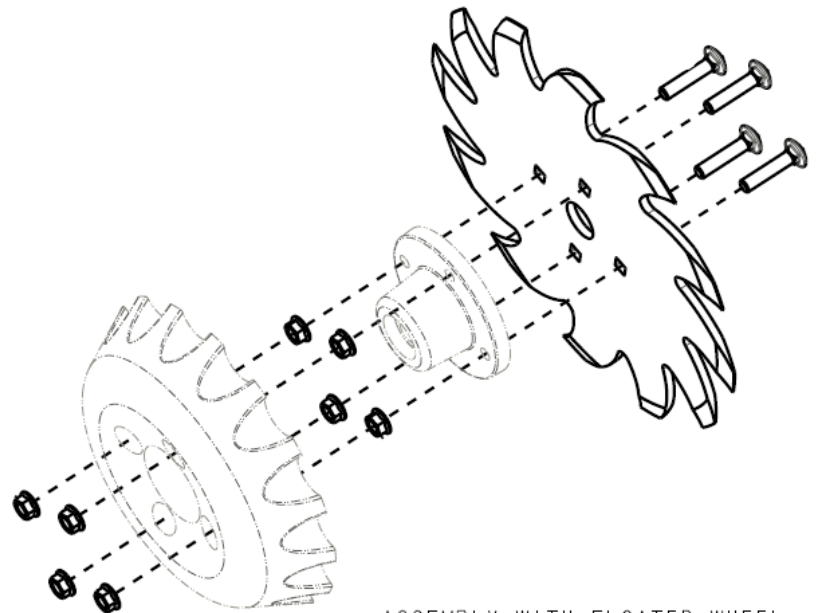
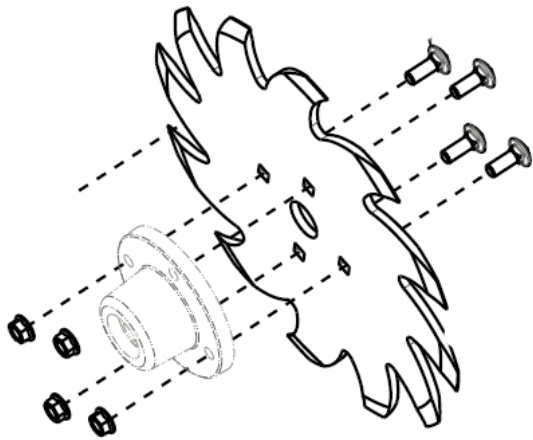

ASSEMBLY WITH FLOATER WHEEL

OPERATION

Row Cleaner operation

In most cases, having the wheels assembled as one wheel leading and one trailing will work best. For the left half of the planter, use left hand wheel leading. And for right hand side of planter, use right hand wheel leading.

Use air pressure to control residue movement while minimizing soil movement.

PART IDENTIFICATION

2967-162

ASSEMBLY WITHOUT FLOATER WHEEL

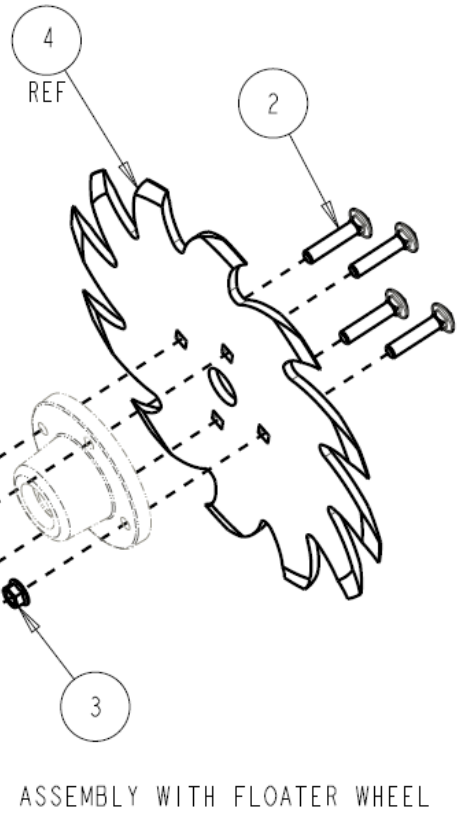
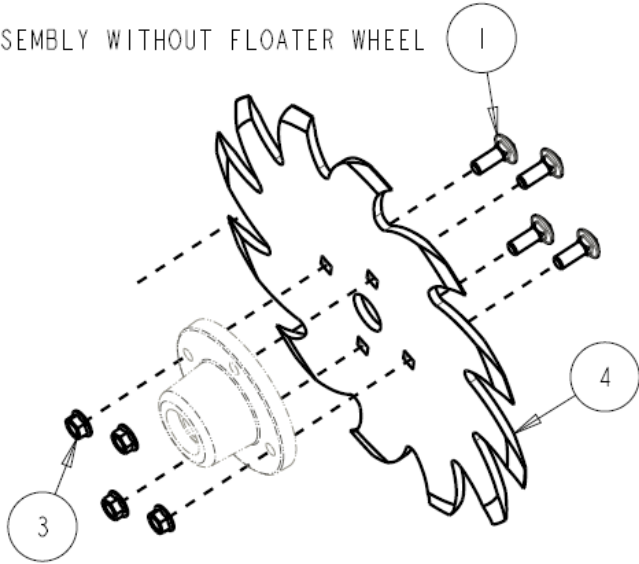

ASSEMBLY WITH FLOATER WHEEL

ITEM	PART NO.	DESCRIPTION	QTY
1	2505-260	ROUND HEAD SHORT SQUARE NECK BOLT ASME B18.5, 3/8-16 X 1, SAE J429, GR5, ZP	4
2	2505-264	ROUND HEAD SHORT SQUARE NECK BOLT ASME B18.5, 3/8-16 X 1.75, SAE J429, GR5, ZP	4
3	2520-260	3/8-16 SERRATED FLANGE LOCK NUT GR. 5 ZP	8
4	2967-602-PP	SHARKTOOTH WHEEL, 4 BOLT	1



A Tradition of Solutions since 1930

Yetter Farm Equipment Co

PO BOX 358 109 S. McDonough

Colchester, IL 62326-0358

Phone: 309-776-4111

Toll Free: 800-447-5777

Email: info@yetterco.com

For updated models and manuals visit the Yetter website:

www.yetterco.com

© Yetter Farm Equipment Co. All Rights Reserved

2565-991 – 02/2025