



**2965 TRASHMASTER
2967 RESIDUE MANAGER**

SET-UP & PARTS MANUAL

2565-631_REV_L • 11/2024



YETTER MANUFACTURING CO.
FOUNDED 1930

Colchester, IL 62326-0358
Toll free: 800/447-5777
309/776-3222 (Fax)

Website: www.yetterco.com
E-mail: info@yetterco.com

YETTER

FOREWORD

You've just joined an exclusive but rapidly growing club.
For our part, we want to welcome you to the group and thank you for buying a Yetter product.

We hope your new Yetter products will help you achieve both goals-increase your productivity and increase your efficiency so that you may generate more profit.

This operator's manual has been designed into four major sections: Foreword, Safety Precautions, Installation Instructions and Parts Breakdown.

This **SAFETY ALERT SYMBOL** indicates important safety messages in the manual. When you see this symbol, be alert to the possibility of **PERSONAL INJURY** and carefully read the message that follows.

 **DANGER:** Indicates an imminently hazardous situation which, if not avoided "will" result in death or serious injury. This signal word is to be limited to the most extreme situations

 **WARNING:** Indicates a potentially hazardous situation which, if not avoided, "could" result in death or serious injury.

 **CAUTION:** Indicates a potentially hazardous situation, which if not avoided, "may" result in minor or moderate injury. It may also be used to alert against unsafe practices.

 **NOTICE:** Indicates information considered important, but not hazard related (e.g., messages relating to property damage).

It is the responsibility of the user to read the operator's manual and comply with the safe and correct operating procedure and to lubricate and maintain the product according to the maintenance schedule in the operator's manual.

The user is responsible for inspecting his machine and for having parts repaired or replaced when continued use of the product would cause damage or excessive wear to the other parts.

It is the user's responsibility to deliver his machine to the Yetter dealer who sold him the product for service or replacement of defective parts, which are covered by the warranty policy.

If you are unable to understand or follow the instructions provided in this publication, consult your local Yetter dealer or contact:

YETTER MANUFACTURING CO.

309/776-4111

800/447-5777

309/776-3222 (FAX)

Website: www.yetterco.com

E-mail: info@yetterco.com

WARRANTY

Yetter Manufacturing warrants all products manufactured and sold by it against defects in material. This warranty being expressly limited to replacement at the factory of such parts or products as shall appear to be defective after inspection. This warranty does not obligate the Company to bear cost of labor in replacement of parts. It is the policy of the Company to make improvements without incurring obligations to add them to any unit already sold. No warranty is made or authorized to be made, other than herein set forth. This warranty is in effect for one year after purchase.

Dealer _____

Yetter Manufacturing warrants its own products only and cannot be responsible for damages to equipment on which mounted.



SAFETY PRECAUTIONS



A brief description of signal words that may be used in this manual:

DANGER: Indicates an imminently hazardous situation which, if not avoided “will” result in death or serious injury. This signal word is to be limited to the most extreme situations.

WARNING: Indicates a potentially hazardous situation which, if not avoided, “could” result in death or serious injury.

CAUTION: Indicates a potentially hazardous situation, which if not avoided, “may” result in minor or moderate injury. It may also be used to alert against unsafe practices.

NOTICE: Indicates information considered important, but not hazard related (e.g., messages relating to property damage).

Consult your implement and tractor operator’s manual for correct and safe operating practices. Be aware of towed implement width and allow safe clearance.

Safety decals are placed on the implement to alert the operator and others to the risk of personal injury or unsafe operation during normal operations and servicing.

1. The safety decals must be kept clean and in good condition to ensure that they are legible.
2. Safety decals must be replaced if they are missing or illegible.
3. When components are replaced during repair or servicing, check that the new components include the necessary safety signs.
4. Replacement safety decals may be obtained from your local dealer.



WARNING

Read these instructions carefully to acquaint yourself with the Equipment. Working with unfamiliar equipment can lead to accidents.

Never park the equipment on a steep incline or leave the equipment running unattended.

Never clean, lubricate or adjust a machine that is in motion.

Always check that straps are secure.

Make sure latches are in pinned position when moving equipment.

Do not allow children to operate this equipment.

Do not allow riders on the equipment, trailer and/or pick-up.

Use speed and caution dictated by the terrain being traversed. Do not operate on any slope steep enough to cause tipping or loss of control.

Read and understand the operator’s manual and require all other persons who will operate the equipment to do the same.

If operating on public roadways, where legal, be certain all lighting is operating properly and observe all traffic laws.

Beware of increased stopping distances and control effort when operating with implements attached.

Be familiar with all controls and be prepared to stop equipment quickly in an emergency.

FAILURE TO HEED MAY RESULT IN PERSONAL INJURY OR DEATH.

TABLE OF CONTENTS

FOREWORD.....2

WARRANTY.....2

SAFETY.....2-3

TABLE OF CONTENTS.....4

OPERATIONS PRECAUTIONS.....5

PLANTER ADJUSTMENT.....6

BOLT TORQUE.....7

INSTALLLATION.....8-9

OPERATING ADJUSTMENTS.....10

PARTS IDENTIFICATION.....11-15

OPERATION PRECAUTIONS

STOP

Read this before using the Yetter product.

- MACHINE OPERATION



NOTICE: failure to properly set the planter frame height and levelness can result in less than successful operation of the planter and the Yetter product and may result in damaged equipment. All operators should read and thoroughly understand the instructions given prior to using the Yetter product.



NOTICE: DO NOT use this product if the planter is not adjusted properly!

Leveling the planter:

With the planter lowered to proper operating height (**Usually 20"-22"**). **Read the planter operator's manual for recommended setting.** Check to be sure the toolbar and row unit parallel arms are level fore and aft. ***Re-check*** when the planter is in the ***field*** and has been ***fully loaded*** with seed, fertilizer, granular chemicals, etc. Also, a field check with a bubble level on the frame should be made of the hitch height to ensure level operation front to back.

It is important for the planter to operate level laterally. Tire pressure must be maintained at pressures specified by the manufacturer.

Field and actual planting conditions change and will dictate planter frame heights. You must ensure that the row unit parallel arms are approximately parallel with the ground.



NOTICE: For proper operation of the planter attachments and row units, it is imperative that the planter toolbars and row unit parallel arms be level side-to-side and front-to-rear. The toolbar frame should operate at a 20"-22" height from the ***planting surface***. Check the manufacturer's operator's manual for instructions on how to adjust the frame height and levelness.

PLANTER ADJUSTMENT

2967-052

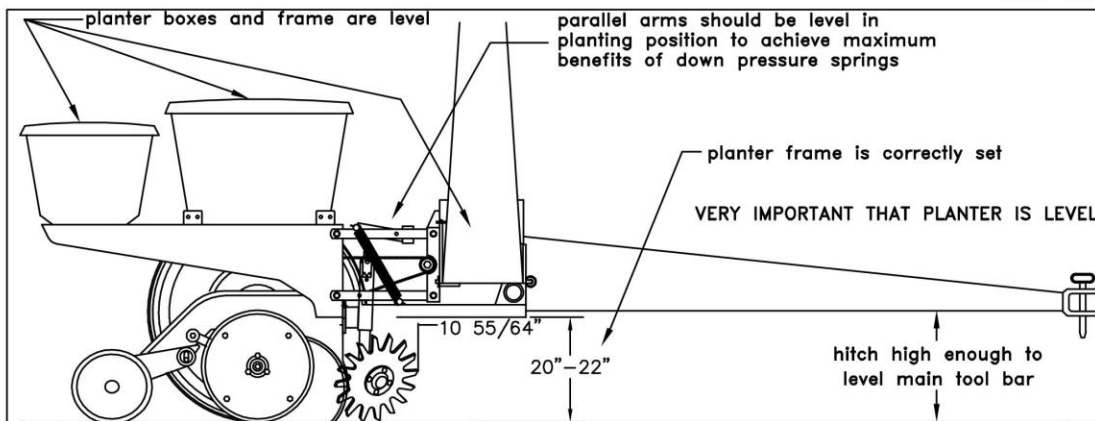

sufficient down pressure
 seed trench properly closed
 seed placement is consistent

FIGURE A. (CORRECT)

S284-18-001

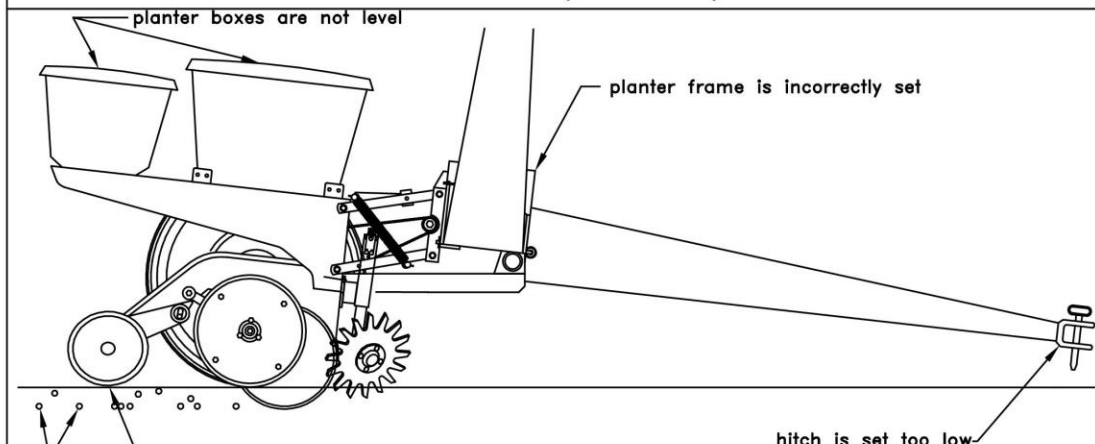
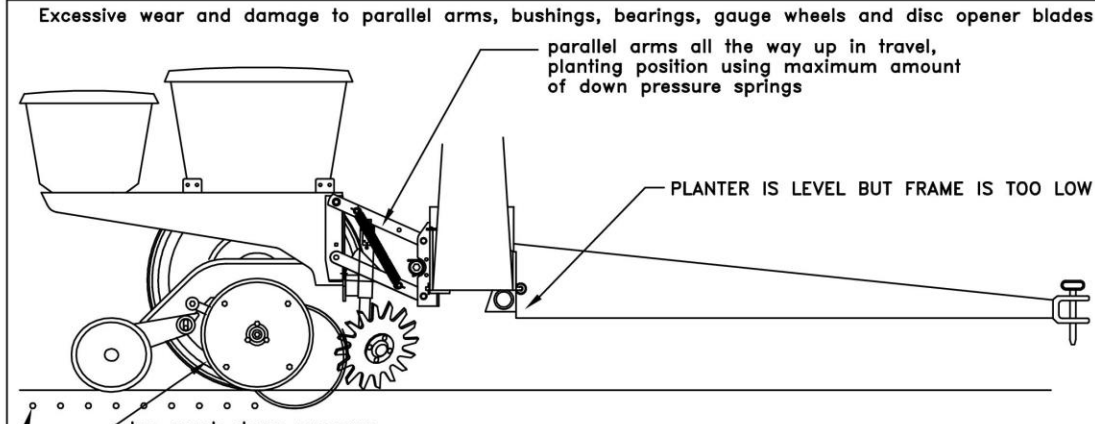

FIGURE B. (INCORRECT)



Excessive wear and damage to parallel arms, bushings, bearings, gauge wheels and disc opener blades
 parallel arms all the way up in travel, planting position using maximum amount of down pressure springs
 PLANTER IS LEVEL BUT FRAME IS TOO LOW
 too much down pressure on gauge wheels
 seed placement is consistently too deep

FIGURE C. (INCORRECT)

BOLT TORQUE

Mounting bolts and hardware

Before operating the Residue Manager for the first time, check to be sure that all hardware is tight. Check all hardware again after approximately 50 hours of operation and at the beginning of each planting season.

All hardware used on the Residue Manager is Grade 5 unless otherwise noted. Grade 5 cap screws are marked with three radial lines on the head. If hardware must be replaced, be sure to replace it with hardware of equal size, strength and thread type. Refer to the torque values chart when tightening hardware.





NOTICE: Over tightening hardware can cause as much damage as when under tightening. Tightening hardware beyond the recommended range can reduce its shock load capacity.

The chart below is a guide for proper torque. Use it unless a specified torque is called out elsewhere in the manual.

Torque is the force you apply to the wrench handle or the cheater bar, times the length of the handle or bar.

Use a torque wrench whenever possible.

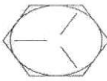
The following table shows torque in ft. lbs. for coarse thread hardware.

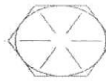
BOLT DIA. AND THREADS PER INCH	 GRADE 2	 OR  GRADE 5 A-325	 GRADE 8
1/4	6	10	14
5/16	12	20	30
3/8 - 16	25	35	50
7/16 - 14	35	55	80
1/2 - 13	55	85	125
9/16 - 12	75	125	175
5/8 - 11	105	170	235
3/4 - 10	185	305	425
7/8 - 9	170	445	690
1-8	260	670	1030
1 1/8 - 7	365	900	1460
1 1/4 - 7	515	1275	2060
1 3/8 - 6	675	1675	2700
1 1/2 - 6	900	2150	3500
1 3/4 - 5	1410	3500	5600

Lubricate all bearings and moving parts as assembled and make certain that they work freely.



WARNING: Never work around the toolbar/implement while in a raised position without using safety lockups.



CAUTION: The Residue Managers are very heavy and sharp. Pay extra attention to lifting techniques while handling and or maneuvering the opener during assembly. Failure to do so may lead to personal injury.

The **2967 Residue Manager** is designed to work in heavy residue situations especially where minimum soil movement is required. Depending on conditions and objectives, the 2967 Residue Manager can be set shallow with the teeth only engaged in the residue so as to clear heavy residue with minimal soil disturbance. Residue Managers are not recommended when surface application pre-plant herbicide is used prior to planting.

INSTALLATION

The universal model that fits on JD 7200/1700 series planters can be mounted two ways (See Figure 1). The front set of holes is to mount these models on planter units with light duty or heavy duty cast lower parallel arms. If the front set of holes is used, assemble two 1/2 bolts, 1/2" x 3-1/2", to the upper and lower rear holes on the mounting bracket using 1/2" locknuts.



NOTICE: Do not over-tighten. The rear set of holes is for planter units with heavy-duty welded lower parallel arms. For this application the 1/2" x 3-1/2" bolts are not used.

MOUNTING ARRANGEMENTS FOR JOHN DEERE 7200/1700 SERIES

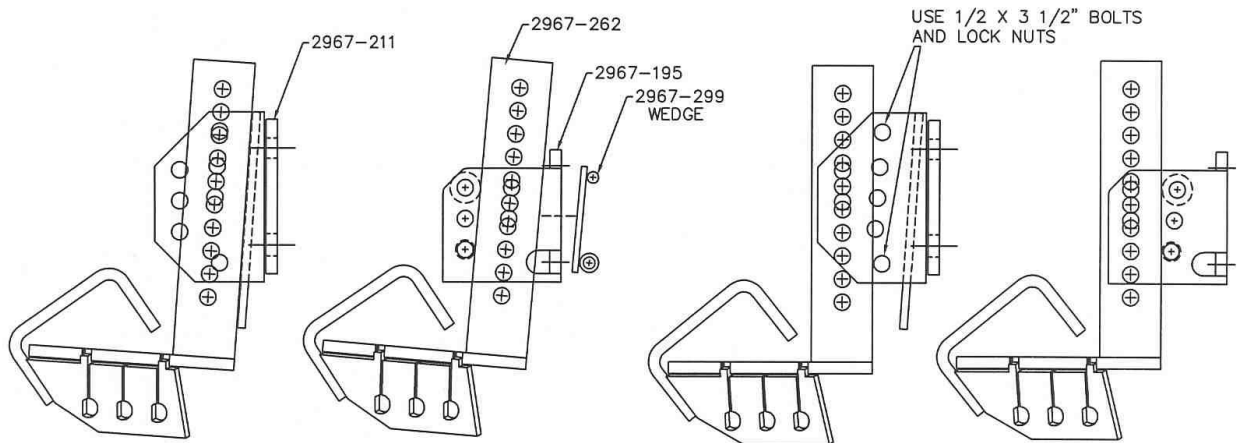

S60-1

**FOR HEAVY DUTY "WELDED"
CAST
LOWER PARALLEL ARMS &
21" LONG PARALLEL ARMS
3000 &
JD7000, KINZE 2000 (PRE 1993)**

**FOR LIGHT DUTY OR HEAVY DUTY
14" LOWER PARALLEL ARMS
ALSO: KINZE 2000 (1993-NEWER),
WHITE 6100, 8000, 9000**

FIGURE 1

INSTALLATION INSTRUCTIONS

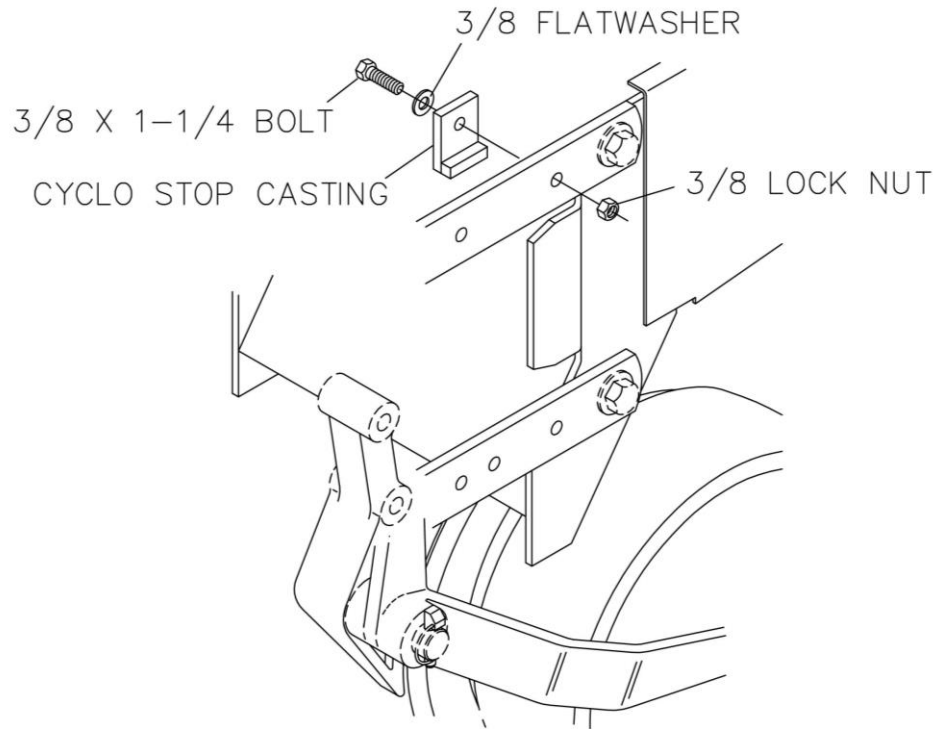

I727-4A

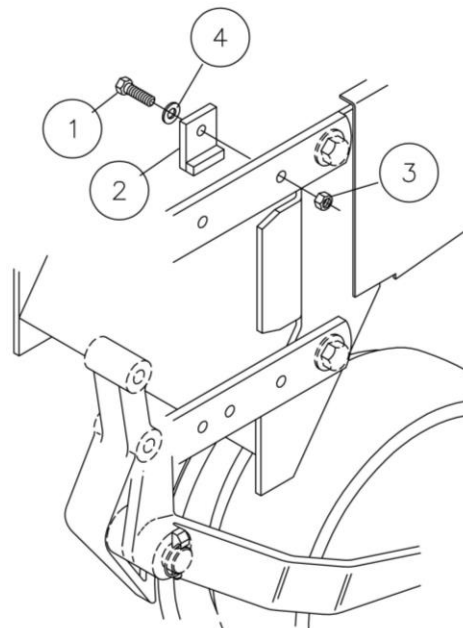

I727-4B

DET	QTY	PART NO.	DESCRIPTION
1	2	2502-244	3/8-16 X 1-1/4 HHCS GR 5
2	2	2960-223	CYCLO STOP
3	2	2520-255	3/8-16 HEX LOCK NUT
4	2	2526-253	3/8 SAE FLATWASHER

OPERATING ADJUSTMENTS

Be sure planter frame is **LEVEL** and at the height stated in the planter operation manual.

DEPTH

Remove spring locking pin and adjustment pin from the wheel support. Raise or lower the stem and wheel assembly so the teeth of the wheels are in solid contact with the residue and lightly touching the soil.

The function of the row cleaner is to sweep aside residue and not move soil. When using pre-plant incorporated herbicide, the row cleaner depth should be adjusted to minimize soil disturbance so the cleaner will not reduce the effectiveness of the incorporated herbicide.

ROW CLEANER

1. **DO NOT** move soil, Residue Managers are designed to move crop residue only.
2. **DO NOT** operate planter at slow speeds, ground speed affects how aggressive the spoke wheels are; operate at sufficient speed to maintain good residue flow.
3. **DO NOT** expect 100% of crop residue to be cleared, it is not necessary and would necessitate engaging the soil. The width of path cleared depends on ground conditions, depth setting and ground speed.
4. **DO** expect to see wheels occasionally quit turning, indicates ideal (shallow) setting which is not moving dirt.
5. **DO** expect the potential to bend or break teeth on wheels in excessively rocky conditions.
6. **DO** adjust planter frame height and drawbar correctly. Very important to ensure planter unit will follow ground contours properly.
7. **DO** adjust planter row unit down pressure kit correctly to prevent excessive depth.
8. **DO** expect finely tilled/soft soils to require adjustment due to lack of resistance, the wheel must turn to move residue.
9. **DO** expect more adjustments to be required in finely tilled or soft soils. In these conditions, the planter may lose flotation requiring adjustment of the residue manager to shallower positions.

PARTS IDENTIFICATION 2967-016A-ST

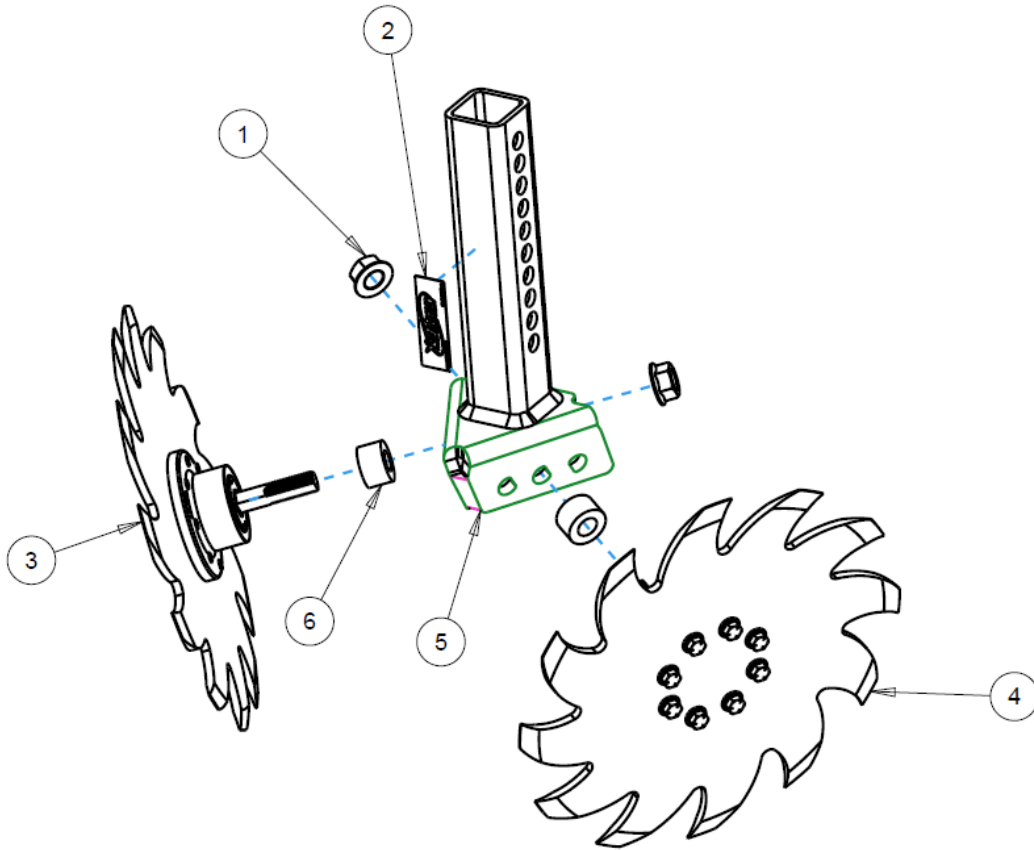

ITEM	PART NO.	DESCRIPTION	QTY
1	2520-465	5/8-11 FLANGE NUT GRADE 8	2
2	2565-179	YETTER DECAL	1
3	2966-102-ST	RIGHT HAND SHARK TOOTH WHEEL ASSEMBLY	1
4	2966-103-ST	LEFT HAND SHARK TOOTH WHEEL ASSEMBLY	1
5	2967-200	STEM	1
6	2967-302	SPACER 3/4"	2

PARTS IDENTIFICATION

2967-195 - R.M. BRACKET ASSEMBLY

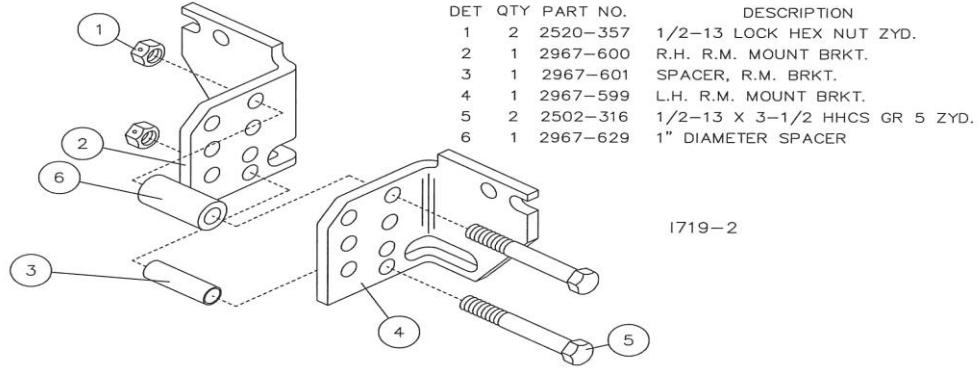

DET	QTY	PART NO.	DESCRIPTION
1	2	2520-357	1/2-13 LOCK HEX NUT ZYD.
2	1	2967-600	R.H. R.M. MOUNT BRKT.
3	1	2967-601	SPACER, R.M. BRKT.
4	1	2967-599	L.H. R.M. MOUNT BRKT.
5	2	2502-316	1/2-13 X 3-1/2 HHCS GR 5 ZYD.
6	1	2967-629	1" DIAMETER SPACER

2967-028A-ST

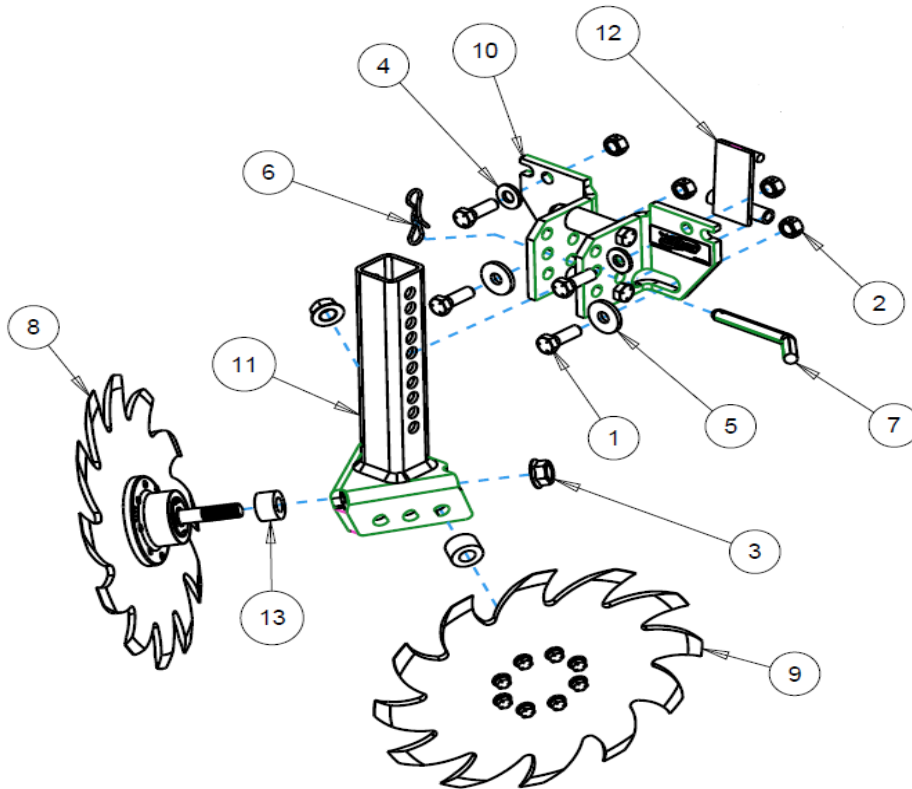

ITEM	PART NO.	DESCRIPTION	QTY
1	2502-294	1/2-13 X 1-1/2 HHCS GRADE 5	4
2	2520-357	1/2-13 LOCK NUT GRADE A	4
3	2520-465	5/8-11 FLANGE NUT GRADE 8	2
4	2526-355	1/2 FLAT WASHER HARDENED	2
5	2527-530	1/2 ID X 1-1/2 OD X 7GA MACHINE WASHER	2
6	2570-448	BOW TIE COTTER PIN	1
7	2965-305	PIN	1
8	2966-102-ST	RIGHT HAND SHARK TOOTH WHEEL ASSEMBLY	1
9	2966-103-ST	LEFT HAND SHARK TOOTH WHEEL ASSEMBLY	1
10	2967-195	MOUNTING BRACKET ASSEMBLY	1
11	2967-200	STEM	1
12	2967-299	WEDGE PLATE	1
13	2967-302	SPACER 3/4"	2

PARTS IDENTIFICATION 2967-106A-ST

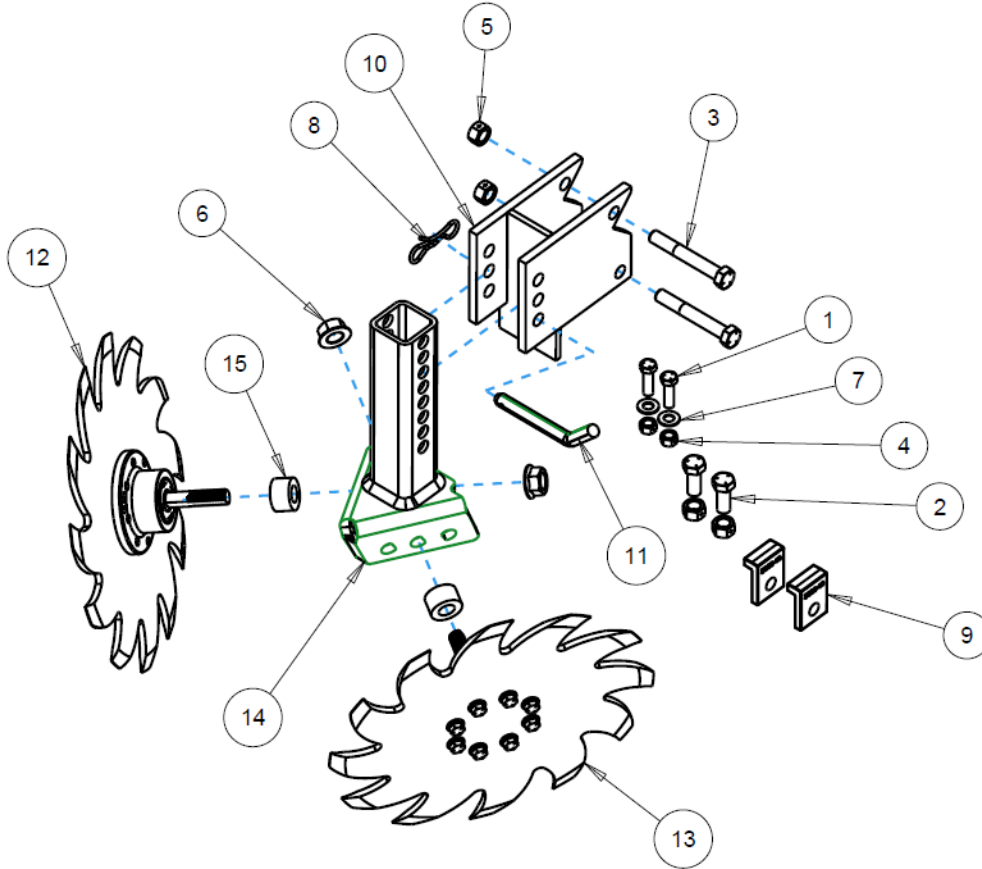

CASE IH 800/900/950/955/1200
WILL NOT FIT 1ST YEAR IHC PRODUCTION (1981)

ITEM	PART NO.	DESCRIPTION	QTY
1	2502-244	3/8-16 X 1-1/4 HHCS GRADE 5	2
2	2502-293	1/2-13 X 1-1/4 HHCS GRADE 5	2
3	2502-316	1/2-13 X 3-1/2 HHCS GRADE 5	2
4	2520-255	3/8-16 LOCK NUT GRADE A	2
5	2520-357	1/2 -13 LOCK NUT GRADE A	4
6	2520-465	5/8-11 FLANGE NUT	2
7	2526-253	3/8 SAE FLAT WASHER	2
8	2570-448	BOW TIE COTTER PIN	1
9	2960-411	ARM STOP	2
10	2965-203	MOUNT BRACKET	1
11	2965-305	PIN	1
12	2966-102-ST	RIGHT HAND SHARK TOOTH WHEEL ASSEMBLY	1
13	2966-103-ST	LEFT HAND SHARK TOOTH WHEEL ASSEMBLY	1
14	2966-272	STEM	1
15	2967-302	SPACER 3/4"	2

PARTS IDENTIFICATION

2966-102-ST

RIGHT HAND ASSEMBLY

ITEM	PART NO.	DESCRIPTION	QTY
1	2502-220	5/16-18 X 3/4 HHFS GR5 ZP	8
2	2571-286	SHARKTOOTH WHEEL, 8 BOLT	1
3	2965-501	HUB ASSEMBLY, 2.406 SPINDLE	1

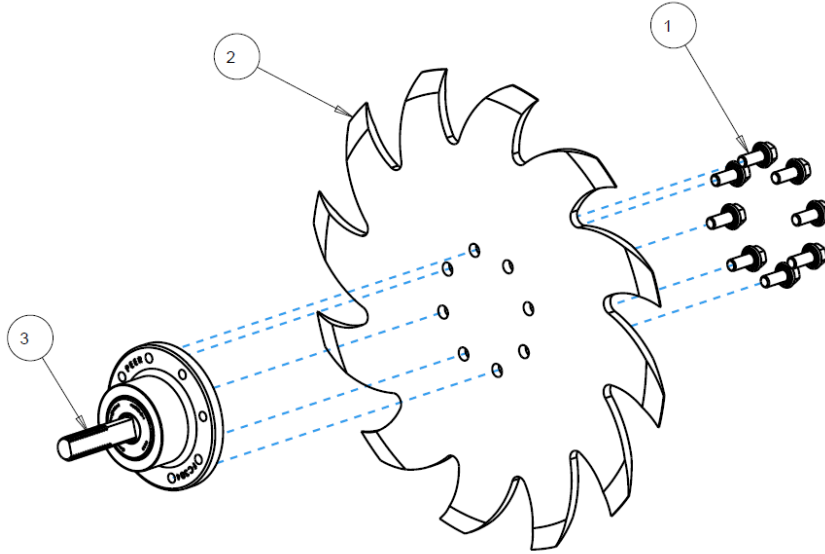

2966-102-BW

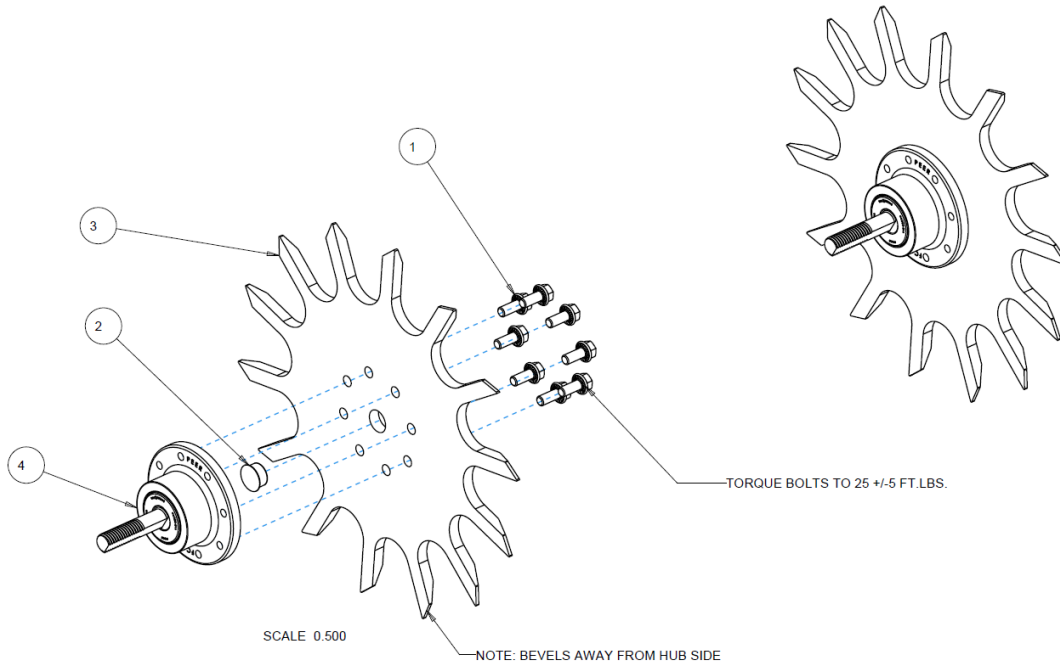

ITEM	PART NO.	DESCRIPTION	QTY
1	2502-220	5/16-18 X 3/4 HHFS GR5 ZP	8
2	2570-994	BEVEL WHEEL CENTER HOLE PLUG	1
3	2571-287-R	13" BEVEL WHEEL, 8 BOLT, RH	1
4	2965-501	HUB ASSEMBLY, 2.406 SPINDLE	1

PARTS IDENTIFICATION

2966-102-STF RIGHT HAND SHARKTOOTH FINGER WHEEL ASSEMBLY

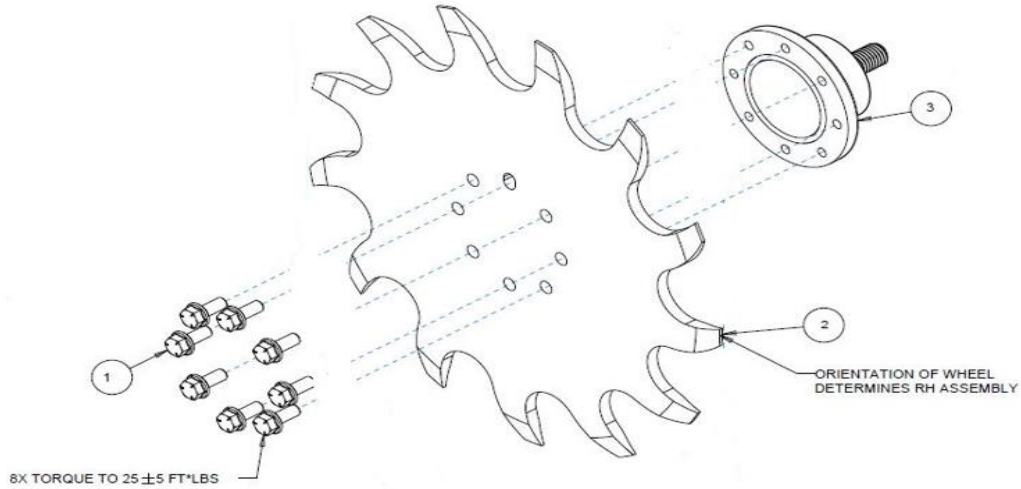

ITEM	QTY	PART NO.	DESCRIPTION
1	8	2502-220	5/16-18 X 3/4 HHFS BOLT GR5
2	1	2571-600	SHARKTOOTH FINGER WHEEL
3	1	2965-501	HUB ASSEMBLY 2.406" SPINDLE

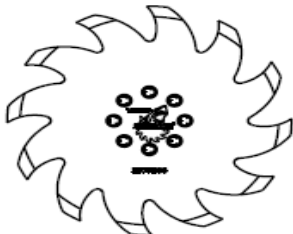

SHARKTOOTH WHEEL ASSEMBLY
RIGHT HAND 2966-140-ST(SHOWN)
LEFT HAND 2966-141-ST



SHARKTOOTH WHEEL ASSEMBLY W/FLOATER WHEEL
RIGHT HAND 2966-140-ST-FW(SHOWN)
LEFT HAND 2966-141-ST-FW

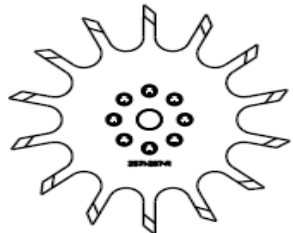

BEVEL WHEEL ASSEMBLY
RIGHT HAND 2966-140-BW(SHOWN)
LEFT HAND 2966-141-BW



BEVEL WHEEL ASSEMBLY W/FLOATER WHEEL
RIGHT HAND 2966-140-BW-FW(SHOWN)
LEFT HAND 2966-141-BW-FW

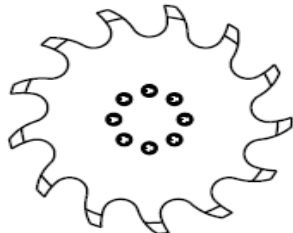

SHARKTOOTH FINGER WHEEL ASSEMBLY
RIGHT HAND 2966-140-STF(SHOWN)
LEFT HAND 2966-141-STF

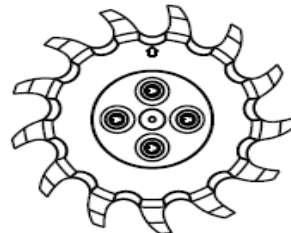

SHARKTOOTH FINGER WHEEL ASSEMBLY W/FLOATER WHEEL
RIGHT HAND 2966-140-STF-FW(SHOWN)
LEFT HAND 2966-141-STF-FW

ISO2966-140_ASSEMBLIES

FIELD SERVICE KITS

- 2965-119 - SERVICE KIT FOR 2570-740-2.812 D-BOLT
- 2965-120 - SERVICE KIT FOR 2570-742-3.812 D-BOLT
- 2965-121 - SERVICE KIT FOR 2570-766-2.562 D-BOLT

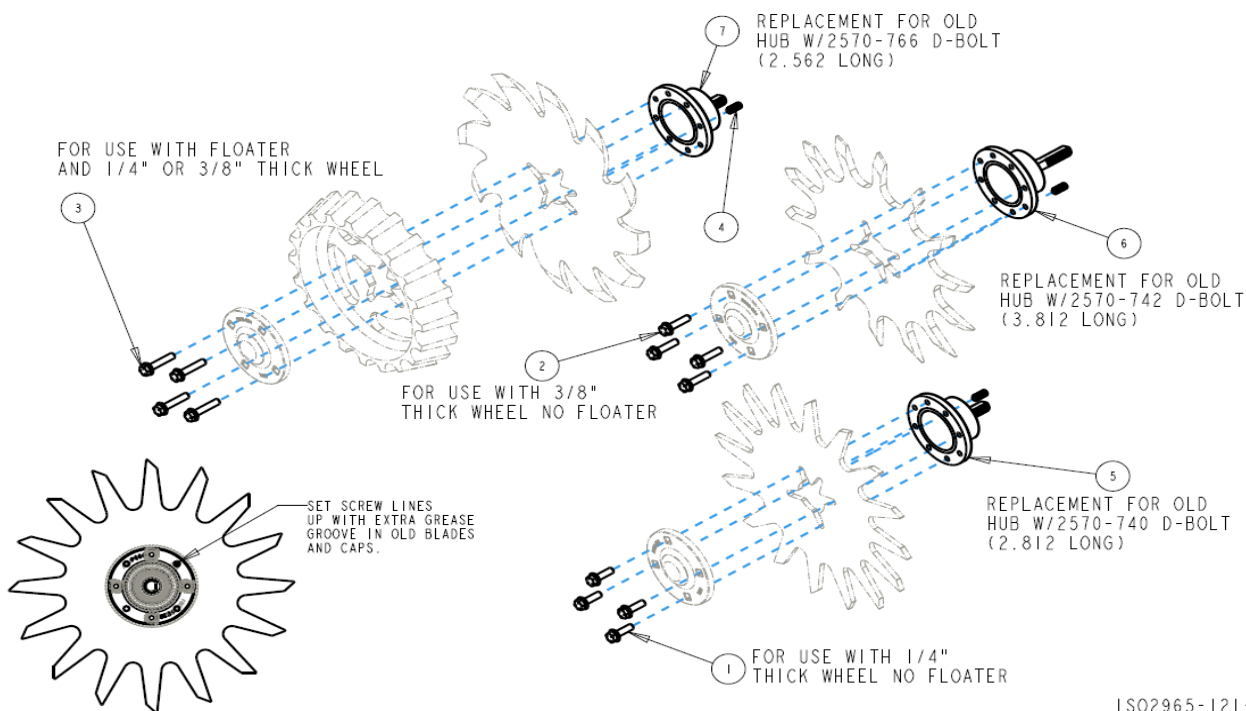

ISO2965-121-2

ITEM	PART NO	DESCRIPTION	QTY
1	2502-221	5/16-18 X 1 HHFS GRADE 5	4
2	2502-222	5/16-18 X 1-1/4 HHFS GRADE 5	4
3	2502-225	5/16-18 X 1-1/2 HHFS GRADE 5	4
4	2940-560	SET SCREW	1
5	2965-500	HUB ASSEMBLY 1.406 SPINDLE	1
6	2965-501	HUB ASSEMBLY 2.406 SPINDLE	1
7	2965-502	HUB ASSEMBLY 1.157 SPINDLE	1



ITEM	PART NO	DESCRIPTION	QTY
1	2505-207	5/16-18 X 1-1/4 CARRIAGE HEAD BOLT GRADE 5	4
2	2520-206	5/16-18 FLANGE LOCK NUT	4
3	2570-742	D-BOLT FLANGE HEAD 5/8-11 X 3.812 GRADE 8	1
4	2965-128	HUB/BEARING ASSEMBLY	1
	2550-069	SEAL	1
	2570-594	BEARING	1
	2570-715	INSERT	1
	2965-351	HUB	1
	2533-110	GREASE FITTING	1
5	2965-352	HUB CAP	1
6	2967-602	SHARK TOOTH WHEEL	1
7	2520-465	5/8-11 FLANGE LOCK NUT GRADE 8	1

OPTIONAL

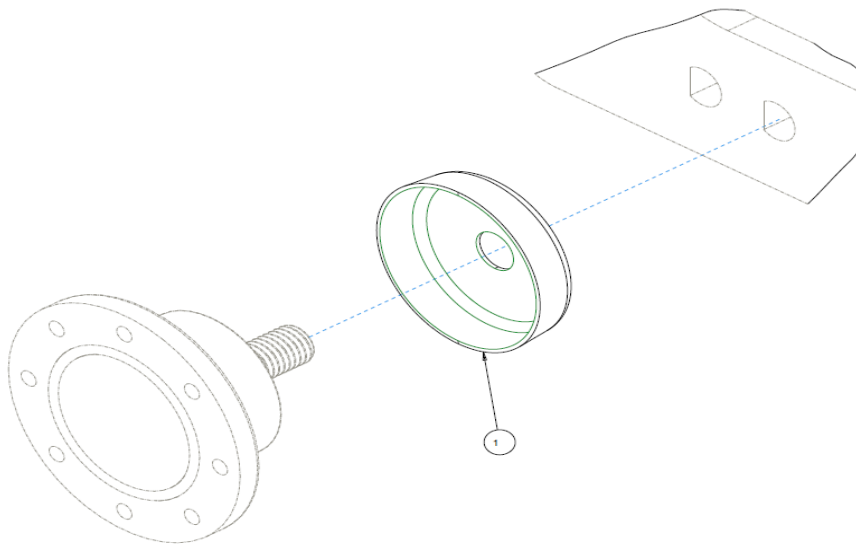

ITEM	PART NO.	DESCRIPTION	QTY
1	2965-550	BEARING SHIELD	1

NOTES

NOTES



A Tradition of Solutions since 1930

Yetter Farm Equipment Co

PO BOX 358 109 S. McDonough

Colchester, IL 62326-0358

Phone: 309-776-4111

Toll Free: 800-447-5777

Email: info@yetterco.com

For updated models and manuals visit the Yetter website:

www.yetterco.com

© Yetter Farm Equipment Co. All Rights Reserved

2565-631_REV_L • 11/2024