

Yetter

FARM EQUIPMENT

TITAN™ SERIES

2967-013C /2967-014C

NARROW ROW SHORT U.N.T.™ RESIDUE MANAGER

OPERATOR'S MANUAL
PART IDENTIFICATION
2565-748_REV_P 11/2024



YETTER MANUFACTURING CO.
FOUNDED 1930

Colchester, IL 62326-0358
Toll free: 800/447-5777
309/776-3222 (Fax)
Website: www.yetterco.com
E-mail: info@yetterco.com

YETTER

FOREWORD

You've just joined an exclusive but rapidly growing club.

For our part, we want to welcome you to the group and thank you for buying a Yetter product.

We hope your new Yetter products will help you achieve both goals-increase your productivity and increase your efficiency so that you may generate more profit.

This operator's manual has been designed into four major sections: Foreword, Safety Precautions, Installation Instructions and Parts Breakdown.

This **SAFETY ALERT SYMBOL** indicates important safety messages in the manual. When you see this symbol, be alert to the possibility of **PERSONAL INJURY** and carefully read the message that follows.

 **DANGER:** Indicates an imminently hazardous situation which, if not avoided "will" result in death or serious injury. This signal word is to be limited to the most extreme situations

 **WARNING:** Indicates a potentially hazardous situation which, if not avoided, "could" result in death or serious injury.

 **CAUTION:** Indicates a potentially hazardous situation, which if not avoided, "may" result in minor or moderate injury. It may also be used to alert against unsafe practices.

 **NOTICE:** Indicates information considered important, but not hazard related (e.g., messages relating to property damage).

It is the responsibility of the user to read the operator's manual and comply with the safe and correct operating procedure and to lubricate and maintain the product according to the maintenance schedule in the operator's manual.

The user is responsible for inspecting his machine and for having parts repaired or replaced when continued use of the product would cause damage or excessive wear to the other parts.

It is the user's responsibility to deliver his machine to the Yetter dealer who sold him the product for service or replacement of defective parts, which are covered by the warranty policy.

If you are unable to understand or follow the instructions provided in this publication, consult your local Yetter dealer or contact:

YETTER MANUFACTURING CO.

309/776-4111

800/447-5777

309/776-3222 (FAX)

Website: www.yetterco.com

E-mail: info@yetterco.com

WARRANTY POLICY

Yetter Manufacturing warrants all products manufactured and sold by it against defects in material. This warranty being expressly limited to replacement at the factory of such parts or products as will appear to be defective after inspection. This warranty does not obligate the Company to bear cost of labor in replacement of parts. It is the policy of the company to make improvements without incurring obligations to add them to any unit already sold. No warranty is made or authorized to be made, other than herein set forth. This warranty is in effect for one year after purchase.

Dealer : _____

Yetter Manufacturing warrants its own products only and cannot be responsible for damage to equipment on which mounted.



SAFETY PRECAUTIONS



A brief description of signal words that may be used in this manual:

DANGER: Indicates an imminently hazardous situation which, if not avoided “will” result in death or serious injury. This signal word is to be limited to the most extreme situations.

WARNING: Indicates a potentially hazardous situation which, if not avoided, “could” result in death or serious injury.

CAUTION: Indicates a potentially hazardous situation, which if not avoided, “may” result in minor or moderate injury. It may also be used to alert against unsafe practices.

NOTICE: Indicates information considered important, but not hazard related (e.g., messages relating to property damage).

Consult your implement and tractor operator's manual for correct and safe operating practices. Be aware of towed implement width and allow safe clearance.

Safety decals are placed on the implement to alert the operator and others to the risk of personal injury or unsafe operation during normal operations and servicing.

1. The safety decals must be kept clean and in good condition to ensure that they are legible.
2. Safety decals must be replaced if they are missing or illegible.
3. When components are replaced during repair or servicing, check that the new components include the necessary safety signs.
4. Replacement safety decals may be obtained from your local dealer.



WARNING

Read these instructions carefully to acquaint yourself with the Equipment. Working with unfamiliar equipment can lead to accidents.

Never park the equipment on a steep incline or leave the equipment running unattended.

Never clean, lubricate or adjust a machine that is in motion.

Always check that straps are secure.

Make sure latches are in pinned position when moving equipment.

Do not allow children to operate this equipment.

Do not allow riders on the equipment, trailer and/or pick-up.

Use speed and caution dictated by the terrain being traversed. Do not operate on any slope steep enough to cause tipping or loss of control.

Read and understand the operator's manual and require all other persons who will operate the equipment to do the same.

If operating on public roadways, where legal, be certain all lighting is operating properly and observe all traffic laws.

Beware of increased stopping distances and control effort when operating with implements attached.

Be familiar with all controls and be prepared to stop equipment quickly in an emergency.

FAILURE TO HEED MAY RESULT IN PERSONAL INJURY OR DEATH.

TABLE OF CONTENTS

SAFETY INFORMATION2-3
BOLT TORQUE..... 4
INSTALLATION INSTRUCTIONS5-6
OPERATION7-9
PART IDENTIFICATION 10-15

BOLT TORQUE



NOTICE: Over tightening hardware can cause as much damage as under tightening. Tightening hardware beyond the recommended range can reduce its shock load capacity.





All hardware used on the Titan™ Residue Manager is Grade 5 unless otherwise specified. If hardware must be replaced, be sure to replace it with hardware of equal size, strength, and thread type.

The chart below is a guide for proper torque. Use it unless a specified torque value is given elsewhere in the manual.

Torque is the force you apply to the wrench handle times the length of the handle.

Use a torque wrench wherever possible

The following table shows torque in ft-lbs for coarse thread hardware.

Bolt Diameter and Threads per Inch				
	Grade 2	Grade 5	A-325	Grade 8
Units	ft-lbs		ft-lbs	ft-lbs
1/4	6		10	14
5/16	12		20	30
3/8 – 16	25		35	50
7/16 – 14	35		55	80
1/2 – 13	55		85	125
9/16 – 12	75		125	175
5/8 – 11	105		170	235
3/4-10	185		305	425
7/8 – 9	170		445	690
1-8	260		670	1030
1 1/8 – 7	365		900	1460
1 1/4 - 7	515		1275	2060
1 3/8 – 6	675		1675	2700
1 1/2 - 6	900		2150	3500
1 3/4 – 5	1410		3500	5600



WARNING: Never work around the toolbar/implement while in a raised position without using safety lockups.



CAUTION: The Titan™ Residue Manager attachments are very heavy. Pay extra attention to lifting techniques while handling and/or maneuvering the opener during assembly. Failure to do so may lead to personal injury.

INSTALLATION INSTRUCTIONS

2967-013A

STEP 1. Attach the Residue Manager Assembly to the planter unit using 3) 1/2" bolts and lock nuts.

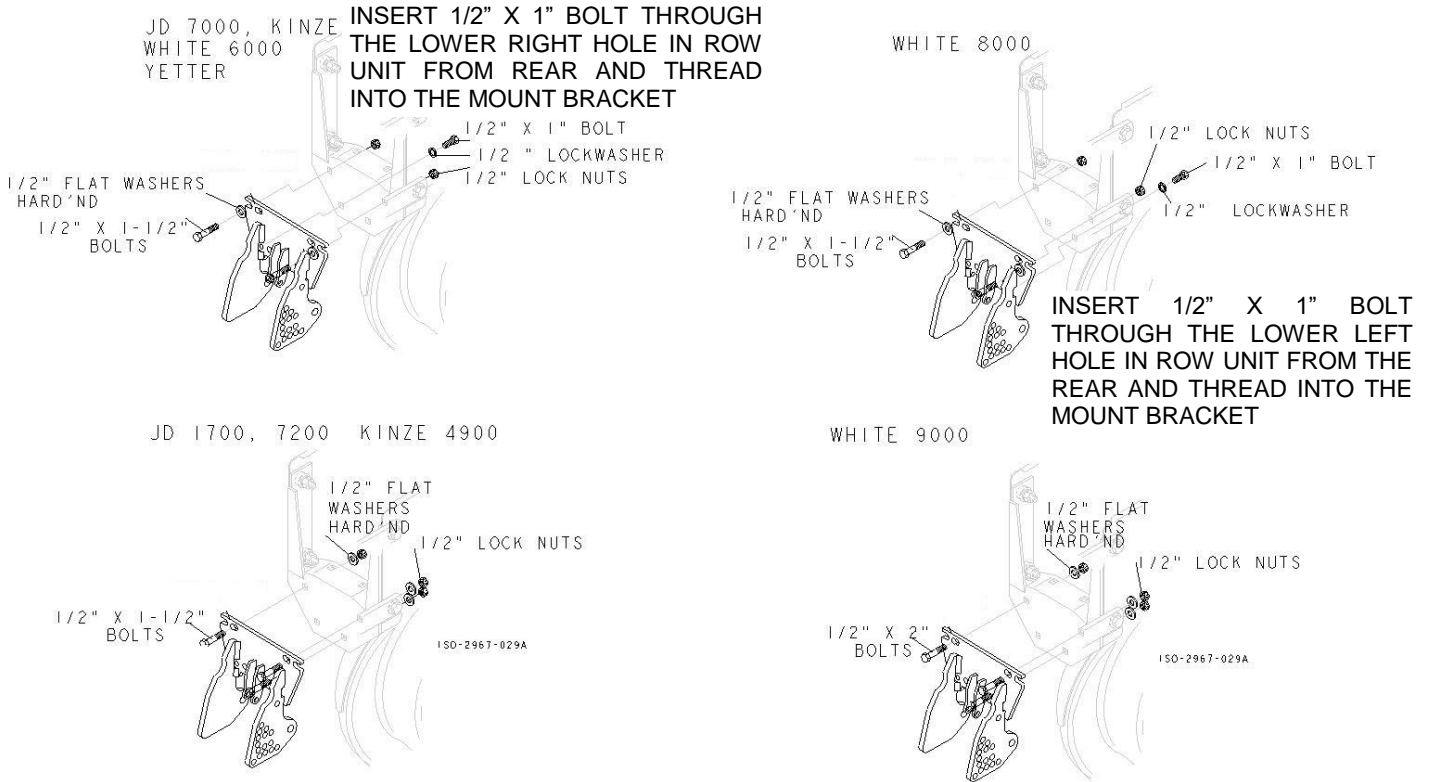

2967-014A

STEP 1A. Attach the 2966-293 adapter to the CIH row unit using the 1/2" x 3-1/2" bolts and lock nuts then install the Residue Manager Assembly to the adapter using the 1/2" x 1-1/2" carriage bolts and flanged lock nuts.

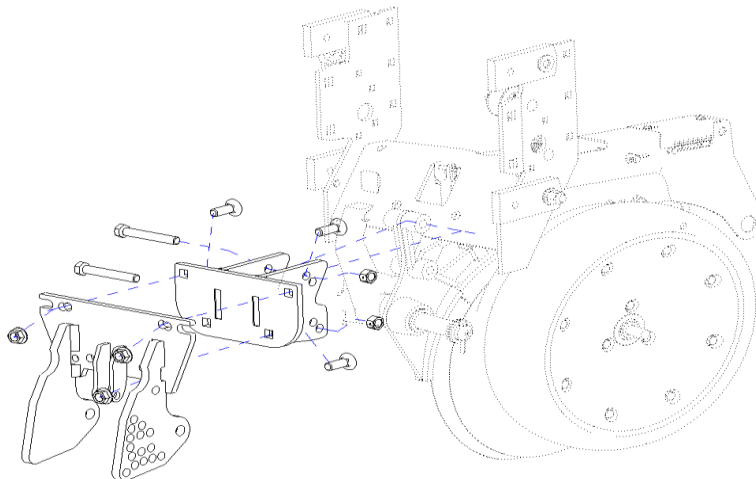

INSTALLATION INSTRUCTIONS

STEP 2. Choose the hole in which to attach the R.M. wheel assemblies. Attach the R.M. wheel/hub assemblies to the combo arm using 5/8" flange hex nuts. Torque to 180 ft. lbs.

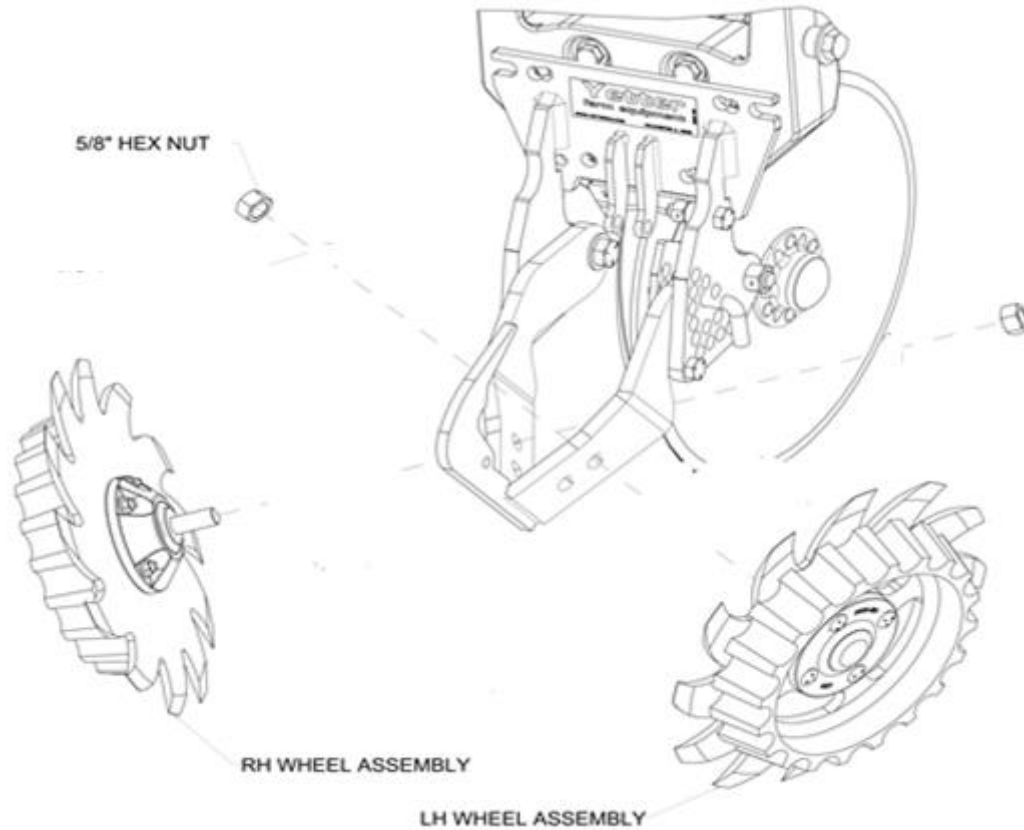

Step 3: ONLY FOR 2967-014B MOUNTING ON CNH RU

Attach the up-stop to the planter row unit parallel arms using the provided hardware.

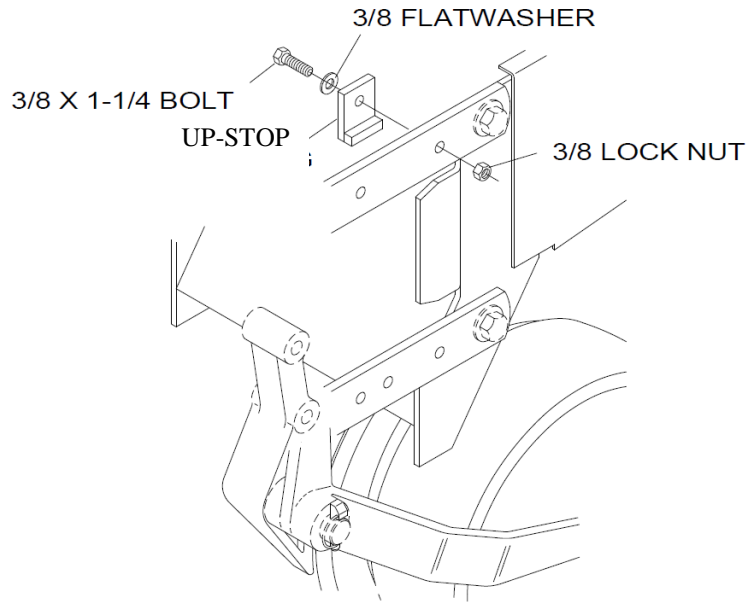

1727-4A

OPERATION



NOTICE: Where rocks are present the residue manager should be set in the “float” position, not locked down.

Adjust the residue manager to move crop residue aside and not move any soil. Adjustments to the residue manager may have to be made when changing field conditions and type and amount of residue. Use the handle for leverage when changing depth settings.

“FLOAT SETTINGS”

Install the adjustment pin below the arm.

To raise the wheels, lift the 2966-291 and move the adjustment pin up.

To lower the wheels, move the adjustment pin down.

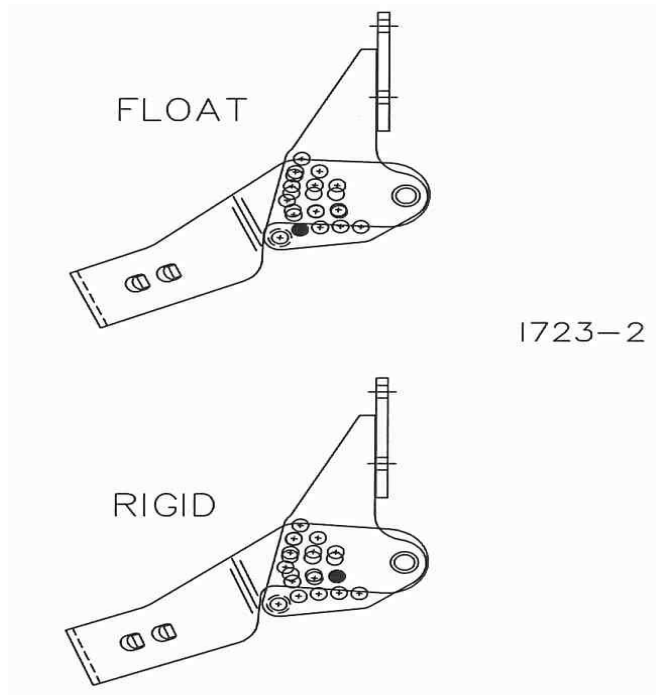

“RIGID SETTING”

Install the adjustment pin through the arm.

To raise the wheels, lift the 2966-291 arm to the desired position and insert the pin.

To lower the wheels, lower the arm to the desired position and insert the pin.

ROW CLEANER DO'S AND DON'TS

1. **DO NOT** move soil; Residue Managers are designed to move crop residue only.
2. **DO NOT** operate planter at slow speeds, ground speed affects how aggressive the spoke wheels are; operate at sufficient speed (4-6 mph) to maintain good residue flow.
3. **DO NOT** expect 100% of crop residue to be cleared, it is not necessary and would necessitate engaging the soil. The width of path cleared depends on ground conditions, depth setting and ground speed.
4. **DO** expect to see wheels occasionally quit turning, indicates ideal (shallow) setting which is not moving soil.
5. **DO** adjust toolbar frame height 20”-22” and drawbar to “level” correctly. Very important to ensure planter opener will follow ground contours properly.

OPERATION PRECAUTIONS

STOP

Read this before using the Yetter product.

- MACHINE OPERATION



NOTICE: failure to properly set the planter frame height and levelness can result in less than successful operation of the planter and the Yetter product and may result in damaged equipment. All operators should read and thoroughly understand the instructions given prior to using the Yetter product.



NOTICE: **DO NOT** use this product if the planter is not adjusted properly!

Leveling the planter:

With the planter lowered to proper operating height (**Usually 20"-22"**). **Read the planter operator's manual for recommended setting**. Check to be sure the toolbar and row unit parallel arms are level fore and aft. **Re-check** when the planter is in the **field** and has been **fully loaded** with seed, fertilizer, granular chemicals, etc. Also, a field check with a bubble level on the frame should be made of the hitch height to ensure level operation front to back.

It is important for the planter to operate level laterally. Tire pressure must be maintained at pressures specified by the manufacturer.

Field and actual planting conditions change and will dictate planter frame heights. You must ensure that the row unit parallel arms are approximately parallel with the ground.



NOTICE: For proper operation of the planter attachments and row units, it is imperative that the planter toolbars and row unit parallel arms be level side-to-side and front-to-rear. The toolbar frame should operate at a 20"-22" height from the **planting surface**. Check the manufacturer's operator's manual for instructions on how to adjust the frame height and levelness.

PLANTER ADJUSTMENT

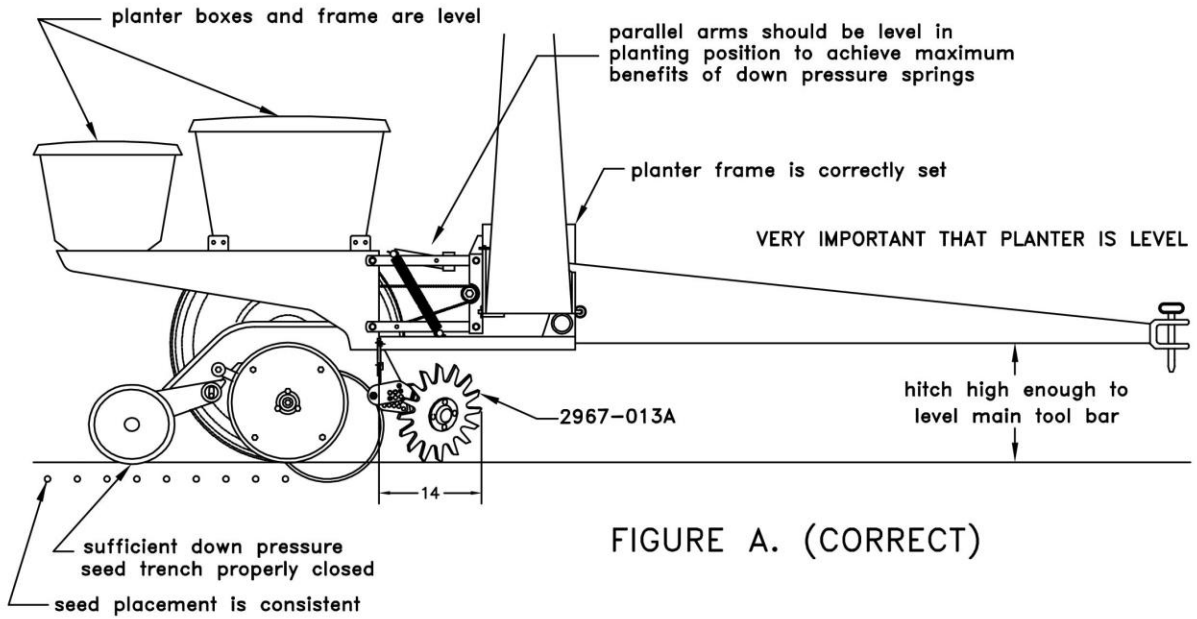

FIGURE A. (CORRECT)

1723-3

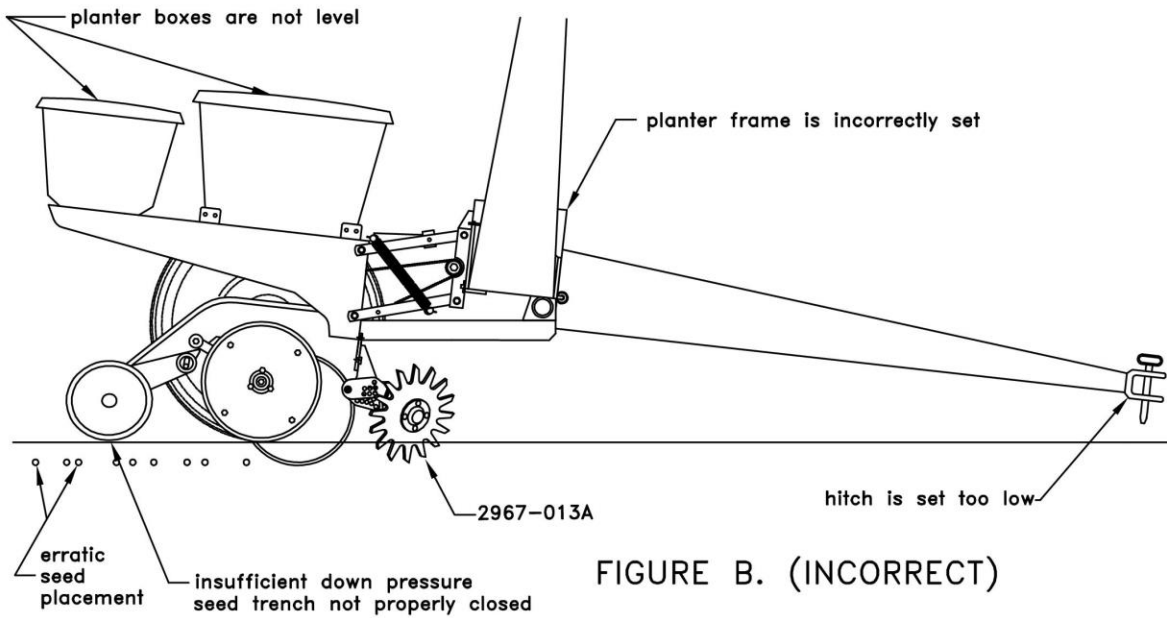
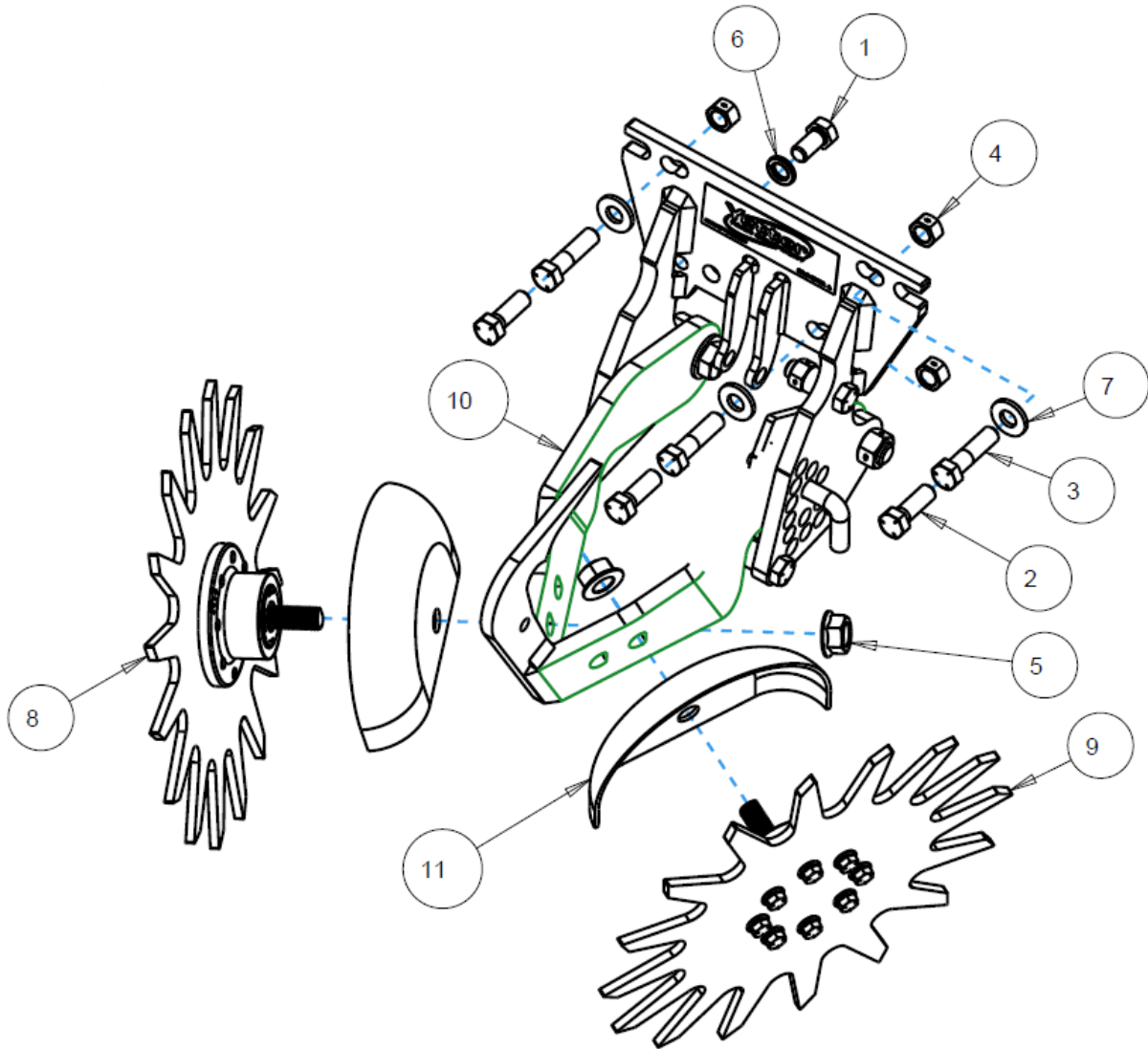

FIGURE B. (INCORRECT)

PART IDENTIFICATION

2967-013C



ITEM	PART NO.	DESCRIPTION	QTY
1	2502-292	1/2-13 X 1 HHCS GRADE 5	1
2	2502-294	1/2-13 X 1-1/2 HHCS GRADE 5	3
3	2502-351	1/2-13 X 2 HHCS GRADE 5	3
4	2520-357	1/2-13 LOCK NUT GRADE A	3
5	2520-465	5/8-11 FLANGE NUT GRADE 8	2
6	2525-352	1/2 LOCK WASHER	1
7	2526-355	1/2 FLAT WASHER HARDENED	3
8	2966-140	RIGHT HAND TAPER TOOTH WHEEL ASSEMBLY	1
9	2966-141	LEFT HAND TAPER TOOTH WHEEL ASSEMBLY	1
10	2967-013C-SUBASSY	NARROW SHORT ARM ASSEMBLY	1
11	2967-392	SHIELD	2

PART IDENTIFICATION 2967-013C-SUB ASSEMBLY

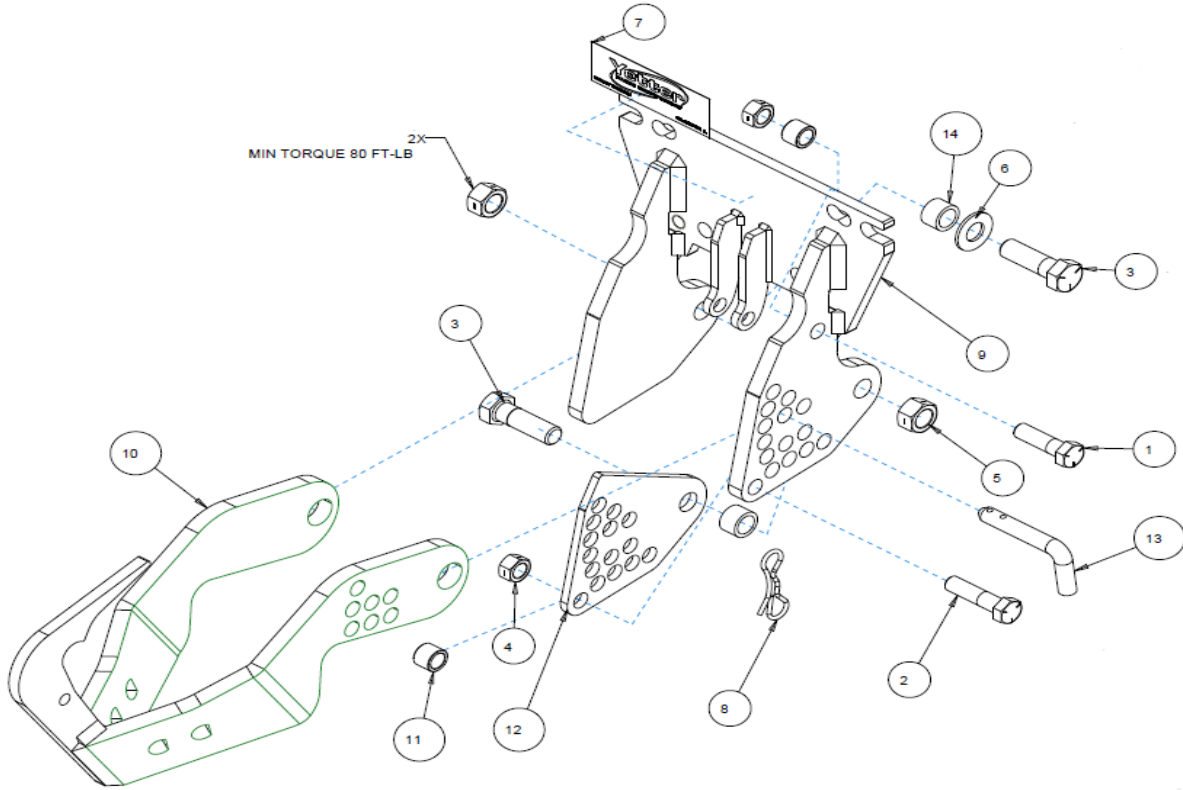

ITEM	PART NO.	DESCRIPTION	QTY
1	2502-317	1/2-13 X 1-3/4 HHCS GRADE 5	1
2	2502-351	1/2-13 X 2 HHCS GRADE 5	1
3	2502-391	5/8-11 X 2 HHCS GRADE 5	2
4	2520-357	1/2-13 LOCK NUT GRADE A	2
5	2520-459	5/8-11 LOCK NUT GRADE B	2
6	2526-453	5/8 SAE FLAT WASHER	1
7	2565-162	YETTER DECAL	1
8	2570-448	BOW TIE COTTER PIN	1
9	2966-290	MOUNT BRACKET	1
10	2966-291A	ARM	1
	6000-560	SPLIT TENSION BUSHING	2
11	2967-861	SPACER	2
12	2967-639	ADJUSTMENT PLATE	1
13	2984-326	PIN	1
14	6000-555	PIVOT BUSHING HARDENED	2



PART IDENTIFICATION 2967-014C

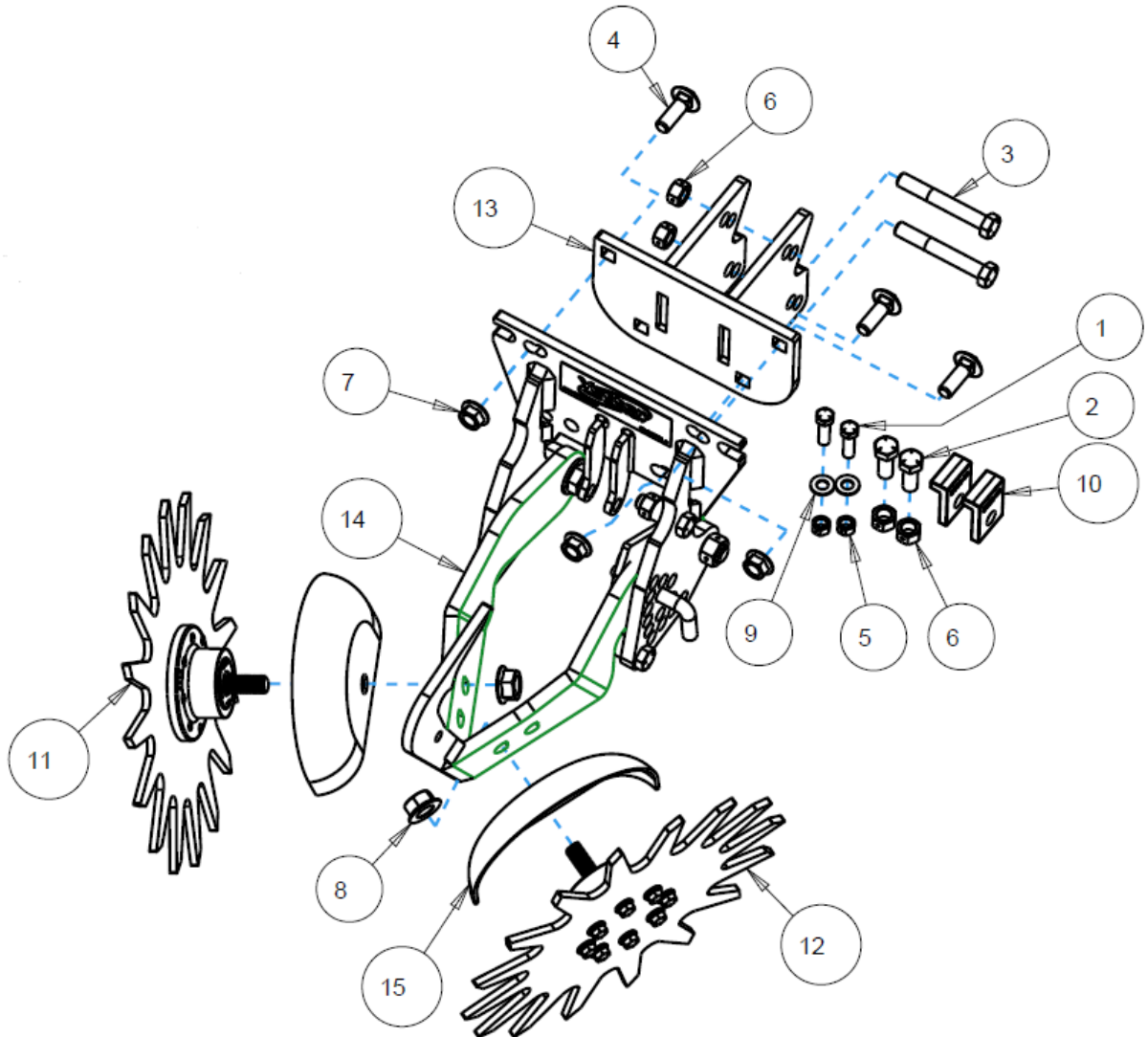

ITEM	PART NO.	DESCRIPTION	QTY
1	2502-244	3/8-16 x 1-1/4 HHCS GRADE 5	2
2	2502-293	1/2-13 X 1-1/4 HHCS GRADE 5	2
3	2502-316	1/2-13 x 3-1/2 HHCS GRADE 5	2
4	2505-339	1/2-13 X 1-1/2 CARRIAGE BOLT	3
5	2520-255	3/8-16 LOCK NUT GRADE A	2
6	2520-357	1/2-13 LOCK NUT GRADE A	4
7	2520-361	1/2-13 FLANGE NUT GRADE 5	3
8	2520-465	5/8-11 LANGE NUT GRADE 8	2
9	2526-253	3/8 SAE FLAT WASHER	2
10	2960-411	ARM STOP	2
11	2966-140	RIGHT HAND TAPER TOOTH WHEEL ASSEMBLY	1
12	2966-141	LEFT HAND TAPER TOOTH WHEEL ASSEMBLY	1
13	2966-293	ADAPTER	1
14	2967-013C SUBASSY	NARROW SHORT ARM ASSEMBLY	1
15	2967-392	SHIELD	2

PARTS IDENTIFICATION

2965-135 UP-STOP KIT

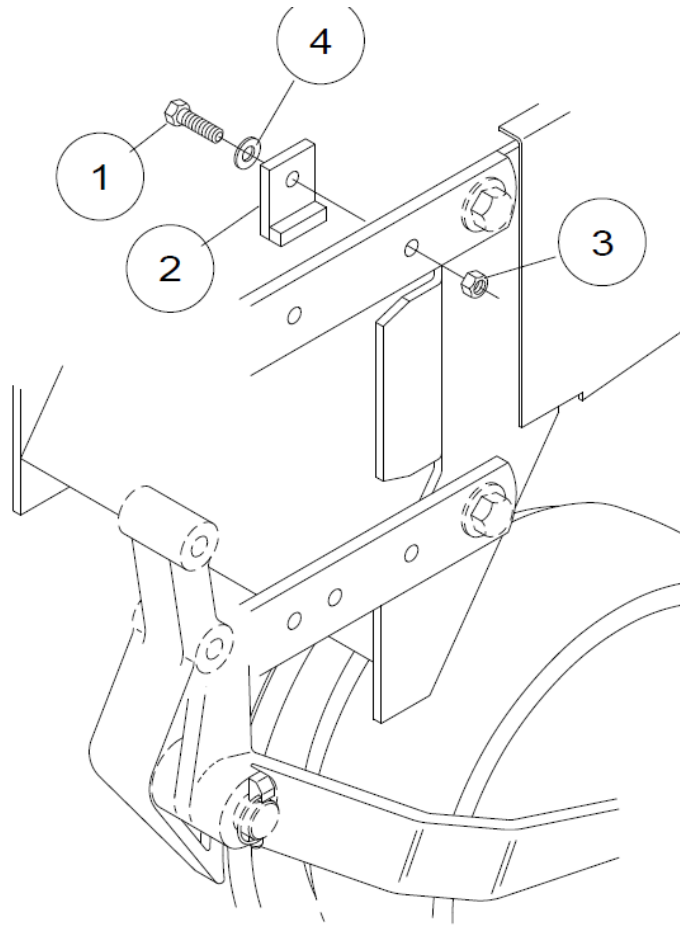

ITEM	PART #	DESCRIPTION	QTY
1	2502-244	3/8-16 x 1-1/4 HHCS GR 5	2
2	2960-223	UP-STOP	2
3	2520-255	3/8-16 HEX LOCK NUT	2
4	2526-253	3/8 SAE FLATWASHER	2

PARTS IDENTIFICATION

2966-140-ST-FW

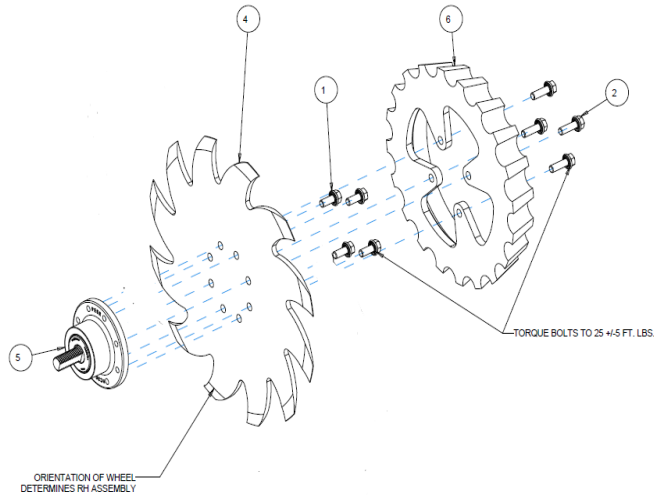

ITEM	PART NO.	DESCRIPTION	QTY
1	2502-220	5/16-18 X 3/4 HHFS GR5 ZP	4
2	2502-221	5/16-18 X 1 HHFS GR5 ZP	4
3	2515-562	13" WHEEL COVER, BLACK	2
4	2571-286	SHARKTOOTH WHEEL, 8 BOLT	1
5	2965-500	HUB ASSEMBLY, 1.406 SPINDLE	1
6	2967-560	FLOATER WHEEL	1

2966-140-ST-PFW

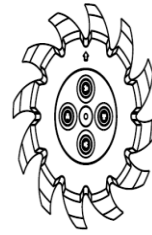

ITEM	PART NO.	DESCRIPTION	QTY
1	2502-220	5/16-18 X 3/4 HHFS GR5 ZP	4
2	2502-221	5/16-18 X 1 HHFS GR5 ZP	4
3	2571-286	SHARKTOOTH WHEEL, 8 BOLT	1
4	2965-500	HUB ASSEMBLY, 1.406 SPINDLE	1
5	2967-957	SHARKTOOTH TIMED FLOATER WHEEL	1

LINE UP ARROW ON FLOATER WITH SLOT ON WHEEL TO INSURE PROPER TIMING OF NOTCHES.

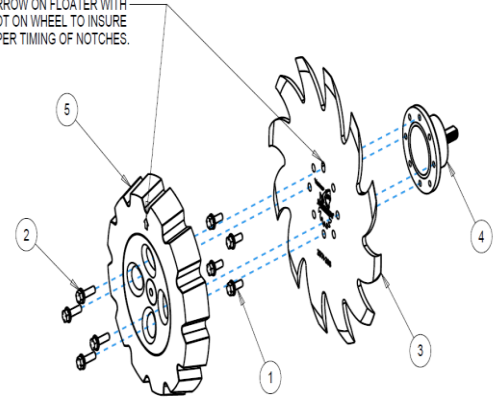

2966-140-BW-FW RIGHT HAND BEVEL WHEEL ASSEMBLY

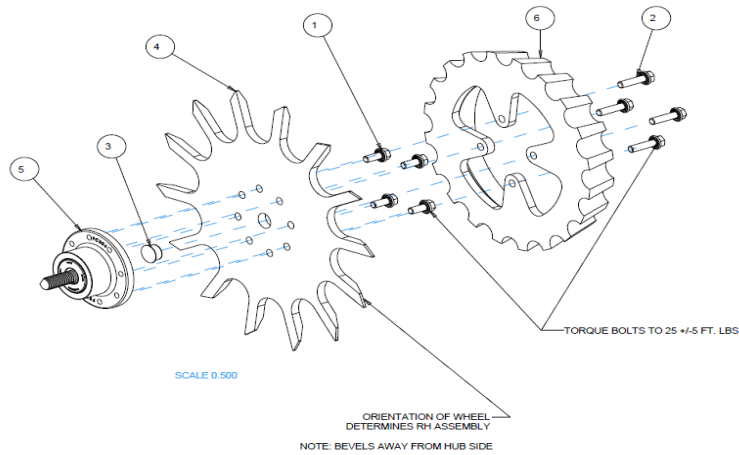

ITEM	PART NO.	DESCRIPTION	QTY
1	2502-220	5/16-18 X 3/4 HHFS GR5 ZP	4
2	2502-222	5/16-18 X 1-1/4 HHFS GR5 ZP	4
3	2570-994	BEVEL WHEEL CENTER HOLE PLUG	1
4	2571-287-R	13" BEVEL WHEEL, 8 BOLT, RH	1
5	2965-500	HUB ASSEMBLY, 1.406 SPINDLE	1
6	2967-560	FLOATER WHEEL	1

PARTS IDENTIFICATION 2966-140-STF-PFW RIGHT HAND SHARK TOOTH WHEEL ASSEMBLY

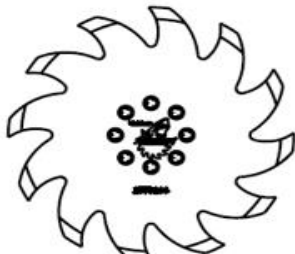
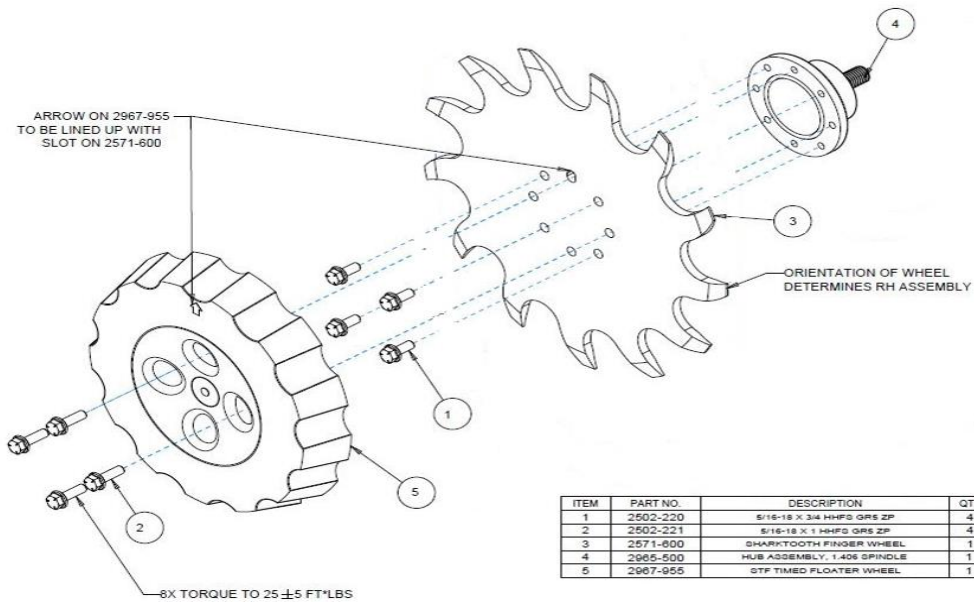

SHARKTOOTH WHEEL ASSEMBLY
RIGHT HAND 2966-140-ST(SHOWN)
LEFT HAND 2966-141-ST



SHARKTOOTH WHEEL ASSEMBLY W/FLOATER WHEEL
RIGHT HAND 2966-140-ST-FW(SHOWN)
LEFT HAND 2966-141-ST-FW



SHARKTOOTH WHEEL ASS'Y W/POLY FLOATER WHEEL
RIGHT HAND 2966-140-ST-PFW(SHOWN)
LEFT HAND 2966-141-ST-PFW



BEVEL WHEEL ASSEMBLY
RIGHT HAND 2966-140-BW(SHOWN)
LEFT HAND 2966-141-BW



BEVEL WHEEL ASSEMBLY W/FLOATER WHEEL
RIGHT HAND 2966-140-BW-FW(SHOWN)
LEFT HAND 2966-141-BW-FW

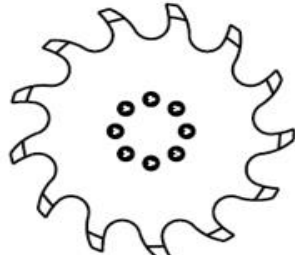

SHARKTOOTH FINGER WHEEL ASSEMBLY
RIGHT HAND 2966-140-STF(SHOWN)
LEFT HAND 2966-141-STF

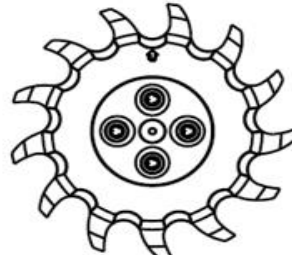

SHARKTOOTH FINGER WHEEL ASSEMBLY W/FLOATER WHEEL
RIGHT HAND 2966-140-STF-FW(SHOWN)
LEFT HAND 2966-141-STF-FW

FIELD SERVICE KITS

- 2965-119 - SERVICE KIT FOR 2570-740-2.812 D-BOLT
- 2965-120 - SERVICE KIT FOR 2570-742-3.812 D-BOLT
- 2965-121 - SERVICE KIT FOR 2570-766-2.562 D-BOLT

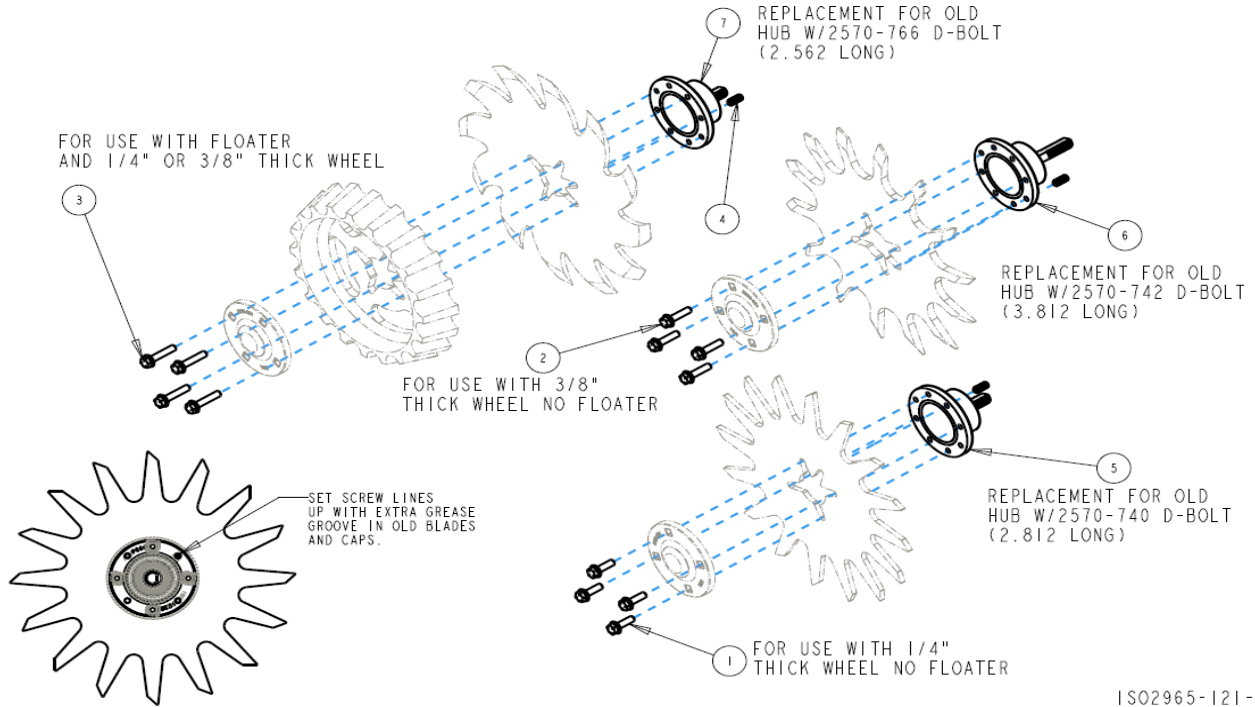

ISO2965-121-2

ITEM	PART NO	DESCRIPTION	QTY
1	2502-221	5/16-18 X 1 HHFS GRADE 5	4
2	2502-222	5/16-18 X 1-1/4 HHFS GRADE 5	4
3	2502-225	5/16-18 X 1-1/2 HHFS GRADE 5	4
4	2940-560	SET SCREW	1
5	2965-500	HUB ASSEMBLY 1.406 SPINDLE	1
6	2965-501	HUB ASSEMBLY 2.406 SPINDLE	1
7	2965-502	HUB ASSEMBLY 1.157 SPINDLE	1

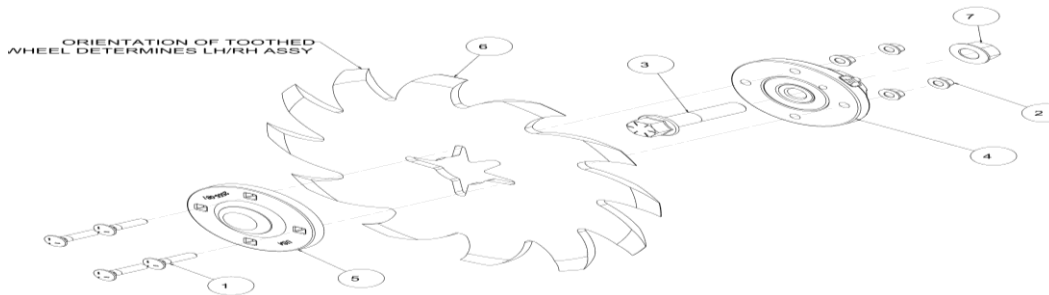

ITEM	PART NO	DESCRIPTION	QTY
1	2505-207	5/16-18 X 1-1/4 CARRIAGE HEAD BOLT GRADE 5	4
2	2520-206	5/16-18 FLANGE LOCK NUT	4
3	2570-740	D-BOLT FLANGE HEAD 5/8-11 X 2.812 GRADE 8	1
4	2965-128	HUB/BEARING ASSEMBLY	1
	2550-069	SEAL	1
	2570-594	BEARING	1
	2570-715	INSERT	1
	2965-351	HUB	1
	2533-110	GREASE FITTING	1
5	2965-352	HUB CAP	1
6	2967-602	SHARK TOOTH WHEEL	1
7	2520-465	5/8-11 FLANGE LOCK NUT GRADE 8	1

OPTIONAL

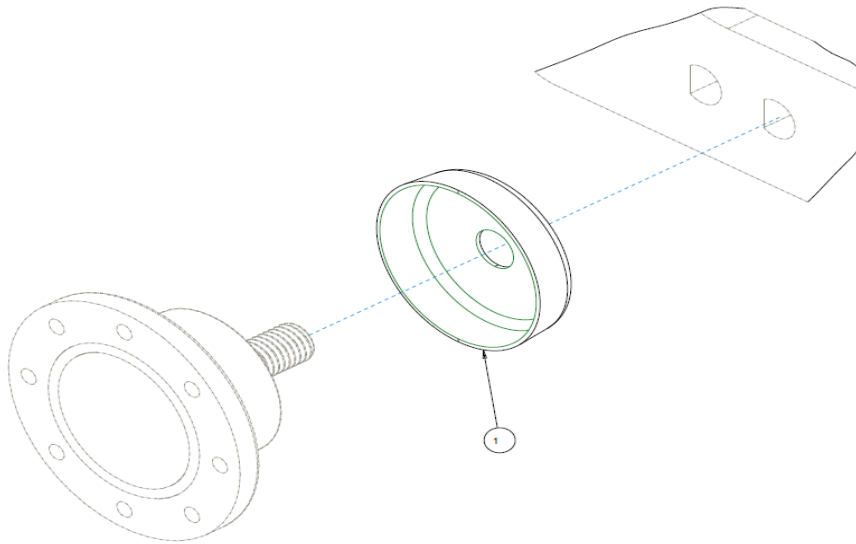

ITEM	PART NO.	DESCRIPTION	QTY
1	2965-550	BEARING SHIELD	1

NOTES

NOTES



A Tradition of Solutions since 1930

Yetter Farm Equipment Co

PO BOX 358 109 S. McDonough

Colchester, IL 62326-0358

Phone: 309-776-4111

Toll Free: 800-447-5777

Email: info@yetterco.com

For updated models and manuals visit the Yetter website:

www.yetterco.com

© Yetter Farm Equipment Co. All Rights Reserved

2565-748_REV_P • 11/2024