

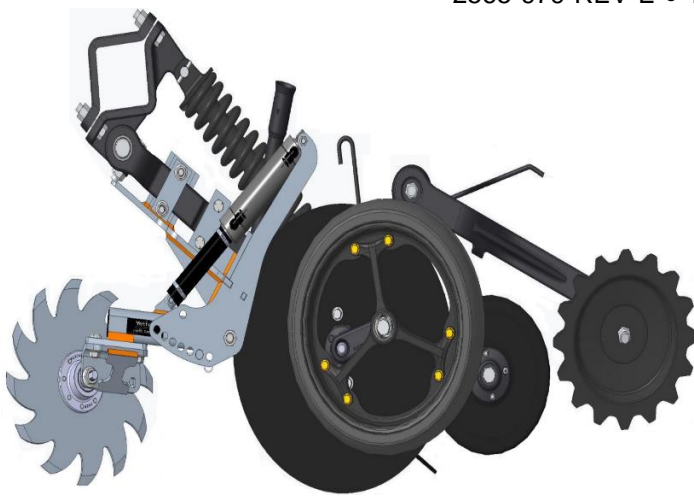

**2966-004 RESIDUE MANAGER FOR 60/90/N500C
JD AIR SEEDERS USING 2940 AIR ADJUST SYSTEM**

2021-PRESENT
OPERATOR'S MANUAL
PART IDENTIFICATION
2565-979-REV-E • 11/2024



*Patented

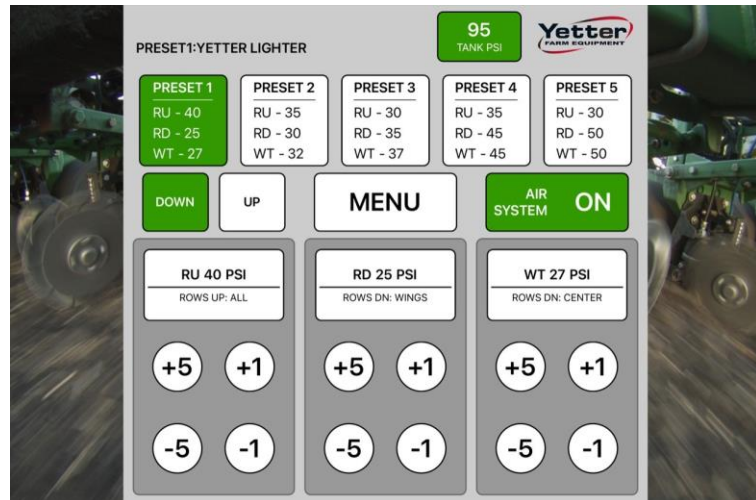

YETTER MANUFACTURING CO.
FOUNDED 1930

Colchester, IL 62326-0358
Toll free: 800/447-5777
309/776-3222 (Fax)
Website: www.yetterco.com
E-mail: info@yetterco.com
serviceteam@yetterco.com

GERMINATE UNIFORMITY™



FOREWORD

You've just joined an exclusive but rapidly growing club.

For our part, we want to welcome you to the group and thank you for buying a Yetter product.

We hope your new Yetter products will help you achieve both goals-increase your productivity and increase your efficiency so that you may generate more profit.

This operator's manual has been designed into four major sections: Foreword, Safety Precautions, Installation Instructions and Parts Breakdown.

This **SAFETY ALERT SYMBOL** indicates important safety messages in the manual. When you see this symbol, be alert to the possibility of **PERSONAL INJURY** and carefully read the message that follows.



DANGER: Indicates an imminently hazardous situation which, if not avoided "will" result in death or serious injury. This signal word is to be limited to the most extreme situations



WARNING: Indicates a potentially hazardous situation which, if not avoided, "could" result in death or serious injury.



CAUTION: Indicates a potentially hazardous situation, which if not avoided, "may" result in minor or moderate injury. It may also be used to alert against unsafe practices.



NOTICE: Indicates information considered important, but not hazard related (e.g., messages relating to property damage).

It is the responsibility of the user to read the operator's manual and comply with the safe and correct operating procedure and to lubricate and maintain the product according to the maintenance schedule in the operator's manual.

The user is responsible for inspecting his machine and for having parts repaired or replaced when continued use of the product would cause damage or excessive wear to the other parts.

It is the user's responsibility to deliver his machine to the Yetter dealer who sold him the product for service or replacement of defective parts, which are covered by the warranty policy.

If you are unable to understand or follow the instructions provided in this publication, consult your local Yetter dealer or contact:

YETTER MANUFACTURING CO.

309/776-4111

800/447-5777

309/776-3222 (FAX)

Website: www.yetterco.com

E-mail: info@yetterco.com

WARRANTY POLICY

Yetter Manufacturing warrants all products manufactured and sold by it against defects in material. This warranty being expressly limited to replacement at the factory of such parts or products as will appear to be defective after inspection. This warranty does not obligate the Company to bear cost of labor in replacement of parts. It is the policy of the company to make improvements without incurring obligations to add them to any unit already sold. No warranty is made or authorized to be made, other than herein set forth. This warranty is in effect for one year after purchase.

Dealer : _____

Yetter Manufacturing warrants its own products only and cannot be responsible for damage to equipment on which mounted.



SAFETY PRECAUTIONS



A brief description of signal words that may be used in this manual:

DANGER: Indicates an imminently hazardous situation which, if not avoided “will” result in death or serious injury. This signal word is to be limited to the most extreme situations.

WARNING: Indicates a potentially hazardous situation which, if not avoided, “could” result in death or serious injury.

CAUTION: Indicates a potentially hazardous situation, which if not avoided, “may” result in minor or moderate injury. It may also be used to alert against unsafe practices.

NOTICE: Indicates information considered important, but not hazard related (e.g., messages relating to property damage).

Consult your implement and tractor operator’s manual for correct and safe operating practices. Be aware of towed implement width and allow safe clearance.

Safety decals are placed on the implement to alert the operator and others to the risk of personal injury or unsafe operation during normal operations and servicing.

1. The safety decals must be kept clean and in good condition to ensure that they are legible.
2. Safety decals must be replaced if they are missing or illegible.
3. When components are replaced during repair or servicing, check that the new components include the necessary safety signs.
4. Replacement safety decals may be obtained from your local dealer.



WARNING

Read these instructions carefully to acquaint yourself with the Equipment. Working with unfamiliar equipment can lead to accidents.

Never park the equipment on a steep incline or leave the equipment running unattended.

Never clean, lubricate or adjust a machine that is in motion.

Always check that straps are secure.

Make sure latches are in pinned position when moving equipment.

Do not allow children to operate this equipment.

Do not allow riders on the equipment, trailer and/or pick-up.

Use speed and caution dictated by the terrain being traversed. Do not operate on any slope steep enough to cause tipping or loss of control.

Read and understand the operator’s manual and require all other persons who will operate the equipment to do the same.

If operating on public roadways, where legal, be certain all lighting is operating properly and observe all traffic laws.

Beware of increased stopping distances and control effort when operating with implements attached.

Be familiar with all controls and be prepared to stop equipment quickly in an emergency.

FAILURE TO HEED MAY RESULT IN PERSONAL INJURY OR DEATH.

TABLE OF CONTENTS

Safety.....	2-3
Bolt Torque.....	4
Hydraulic Fittings Chart.....	5
Components, Kits, and Part Numbers.....	6 – 9
Introduction & System Requirements.....	10
System Information.....	11 – 15
Installation Guide.....	16 – 17
Residue Manager Installation.....	18
Tablet Mount / Power Harness	19
2940-103A Control Box Installation.....	20
2940-415 Water Separator/Regulator Assembly Installation.....	20
ISOBUS Installation.....	21
Yetter Compressor Installation.....	22 – 25
Compressor to Control Box Airline Installation.....	26
Lift Kit & Dump Valve Installation.....	27
Airline Installation.....	28 – 30
Operation.....	31 – 37
Maintenance.....	38 – 41
Parts Identification.....	42 – 52
Troubleshooting.....	53
Notes.....	55

BOLT TORQUE

Regularly inspect each residue manager for loose or worn bolts & hardware. Repair or replace as needed.



All hardware used on the 2940 Air Adjust is Grade 5 unless otherwise noted. Grade 5 cap screws are marked with three radial lines on the head. If hardware must be replaced, be sure to replace it with hardware of equal size, strength and thread type. Refer to the torque values chart when tightening hardware.



NOTICE: Over tightening hardware can cause as much damage as when under tightening. Tightening hardware beyond the recommended range can reduce its shock load capacity.

The chart below is a guide for proper torque. Use it unless a specified torque is called out elsewhere in the manual. Torque is the force you apply to the wrench handle or the cheater bar, times the length of the handle or bar. Use a torque wrench whenever possible.

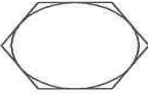
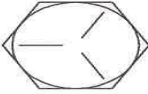
The following table shows torque in ft. lbs. for coarse thread hardware.

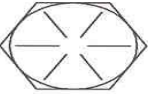
BOLT DIA. AND THREADS PER INCH		 OR 	
	GRADE 2	GRADE 5 A-325	GRADE 8
3/8-16	25	35	50
7/16-14	35	55	80
1/2-13	55	85	125
9/16-12	75	125	175
5/8-11	105	170	235
3/4-10	185	305	425
7/8-9	170	445	690
1-8	260	670	1030
1 1/8-7	365	900	1460
1 1/4-7	515	1275	2060
1 3/8-6	675	1675	2700
1 1/2-6	900	2150	3500
1 3/4-5	1410	3500	5600

Hydraulic Fittings Identification Chart

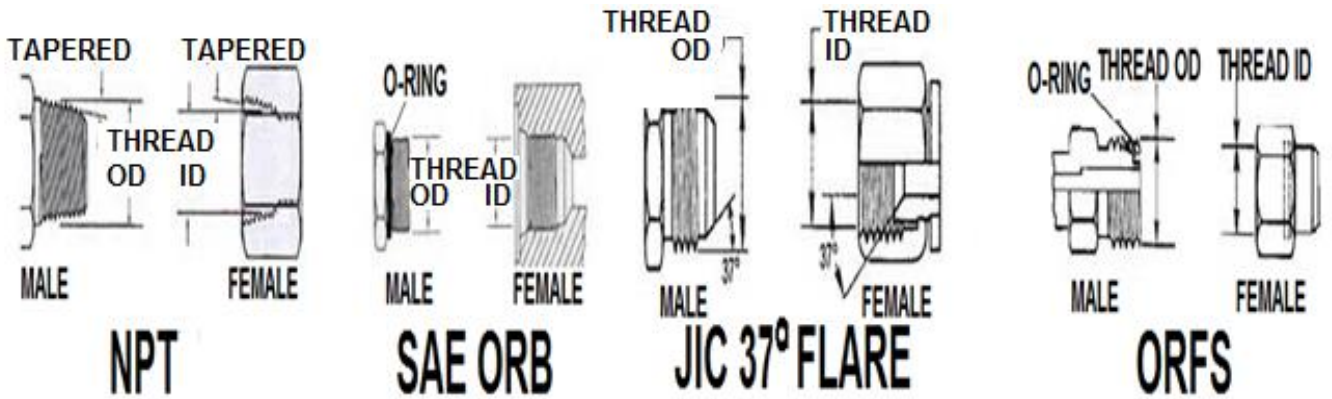

Nominal Size	Dash Size	Nominal Thread	Male Thd OD	Female Thd ID	Nominal Thread	Male Thd OD	Female Thd ID	Nominal Thread	Male Thd OD	Female Thd ID	Nominal Thread	Male Thd OD	Female Thd ID
1/8	02	1/8-27	0.41	0.38	5/16-24	0.31	0.27	5/16-24	0.31	0.27	NOT AVAILABLE		
3/16	03	NOT AVAILABLE			3/8-24	0.38	0.34	3/8-24	0.38	0.34	NOT AVAILABLE		
1/4	04	1/4-18	0.54	0.49	7/16-20	0.44	0.39	7/16-20	0.44	0.39	9/16-18	0.56	0.51
5/16	05	NOT AVAILABLE			1/2-20	0.50	0.45	1/2-20	0.50	0.45	NOT AVAILABLE		
3/8	06	3/8-18	0.68	0.63	9/16-18	0.56	0.51	9/16-18	0.56	0.51	11/16-16	0.69	0.63
1/2	08	1/2-14	0.84	0.77	3/4-16	0.75	0.69	3/4-16	0.75	0.69	13/16-16	0.82	0.75
5/8	10	NOT AVAILABLE			7/8-14	0.88	0.81	7/8-14	0.88	0.81	1-14	1.00	0.93
3/4	12	3/4-14	1.05	0.98	1 1/16-12	1.06	0.98	1 1/16-12	1.06	0.98	1 3/16-12	1.19	1.11
7/8	14	NOT AVAILABLE			1 13/16-12	1.19	1.10	1 13/16-12	1.19	1.10	NOT AVAILABLE		
1	16	1-11 1/2	1.32	1.24	1 5/16-12	1.31	1.23	1 5/16-12	1.31	1.23	1 7/16-12	1.44	1.36
1 1/4	20	1 1/4-11 1/2	1.66	1.58	1 5/8-12	1.63	1.54	1 5/8-12	1.63	1.54	1 11/16-12	1.69	1.61
1 1/2	24	1 1/2-11 1/2	1.90	1.82	1 7/8-12	1.88	1.79	1 7/8-12	1.88	1.79	2-12	2.00	1.92
2	36	2-11 1/2	2.38	2.30	2 1/2-12	2.50	2.42	2 1/2-12	2.50	2.42	NOT AVAILABLE		

- Due to common threads, mismatching can happen and could result in leaks and pressure loss
- Be sure to verify which style and use dash sizes when ordering replacement parts

Thread Styles

-NPT is easily recognizable as tapered National Pipe Thread. It is not recommended for hydraulic systems but does exist on some agriculture equipment. Teflon tape is required.

-SAE ORB is recommended by the NFPA for optimal leakage control in medium and high pressure hydraulic systems. The male fitting has a straight thread and O-ring. The female port has a straight thread, a machined surface (minimum spot face) and a chamfer to accept the O-ring. The seal takes place by compressing the O-ring in the chamfer. The threads hold the connection mechanically.

-JIC 37 Degree Flare fittings have a 37° cone seat on the female adapter and a 37° flare on the male adapter. This cone seat and flare allows for a complete mechanical seal between the male and female fitting. Teflon tape on threads is not required.

-ORFS (O-Ring Face Seal) adapter fittings use a straight thread and have a machined groove in the face of the male fitting to accept the O-ring. This O-ring is compressed against the flat face of the female fitting for a leak proof connection. ORFS are one of the newest types of hydraulic fittings.

Components, Kits, Accessories, & Ordering Numbers

Residue Manager Kits

- 2966-004-L Pneumatic Residue Manager (RM) Assembly, LH, JD 60/90/PRO SERIES: choice of wheel kit
 2966-004-R Pneumatic Residue Manager (RM) Assembly, RH, JD 60/90/PRO SERIES: choice of wheel kit

Control Box, Compressors, Air Lines, & Wiring Kits

- 2940-050A Pneumatic Compressor Kit Electric
 2940-053A Pneumatic Control Box (3 Pneumatic Output Controls)
 2940-055 Pneumatic Compressor Kit Hydraulic
 2940-075A 6, 8, & 12 Row Wiring and Tubing Kit
 2940-076A 16 Row Wiring and Tubing Kit
 2940-077A 24 Row Wiring and Tubing Kit
 2940-078A 32, 36, 48, & 54 Row Wiring and Tubing Kit
 2966-050 Lift Kit for 2966 Pneumatic Residue Manager

Mounting Kits

- 2940-082 5X7 and 7X7 Bar Mount Kit (for 2940-103A Control Box)
 2940-083 8X16 and 8X12 Bar Mount Kit (for 2940-103A Control Box)
 2940-084 Universal Hand Rail Mount Kit (for 2940-103A Control Box)
 2940-085 Two Point or Universal Hydraulic Compressor Mount Kit
 2940-086 Draft Tube or Universal Hydraulic Compressor Mount Kit
 2940-090 8X12 Bar Hydraulic Compressor Mount Kit
 2940-091 8X16 Bar Hydraulic Compressor Mount Kit
 2940-111 RAM Tablet Mount, 9"-10" Tablet size

Part Numbers & Descriptions

- 2940-087A ISOBUS Kit (Tractor Hitch)
 2940-087A-JD Rear ISOBUS Kit, John Deere
 2940-088 Hydraulic Hose and Fitting Kit (Planter)
 2940-089 Hydraulic Hose and Fitting Kit (Stand Alone)



- 2940-101A Electric Compressor Unit----->
 <-----2940-103A Control Box for Hydraulic Compressors



- 2940-106 Hydraulic Compressor Unit----->
 <-----2940-112A VDM 12 Volt Controller, MIDAC



- 2940-653 JCA Thrasher Module----->
 <-----2940-111 RAM Tablet Mount Kit



- 2940-147 Package of 10 Tees----->
 <-----2940-148 Package of Zip Ties (100)



- 2940-150 Main Power Cable with 80A Breaker----->



- <-----2940-151 10 ft. Main Power Cable Extension



- 2940-153A IGN/GRD Supply Harness, 15ft----->



- <-----2940-154 30 ft. Dump Valve Harness Black **(Used on Stand Alone Compressor Only)**



- 2940-163 20 ft Main Power Extension----->



- <-----2940-164A 5 ft. AUX to Air Harness



- 2940-165A 10 ft. AUX to Air Harness



- 2940-166 VDM Power Cable with 40 Amp Breaker----->



- <-----2940-167 10 ft. VDM Power Cable Extension

- 2940-168 20 ft. VDM Power Cable Extension

- 2940-170A 10 ft. AUX to Air Harness Extension ----->

- 2940-171A 30 ft. AUX to Air Harness Extension

Components, Kits, Accessories, & Ordering Numbers



2940-174 Spare Fitting Bag
 ←-----2940-181 Hyd. Compressor Solenoid/Switch Harness

2940-182 20Ft Hyd. Compressor Control Harness-----→
 2940-183 Hardware Bolt Bag for 2940-083 kit
 2940-184 Hardware Bolt Bag for 2940-084 kit
 2940-185 Hardware Bolt Bag for 2940-085 kit
 2940-186 Hardware Bolt Bag for 2940-086 kit
 2940-189 10Ft Hyd. Compressor Control Harness



←-----2940-337 3/8 Push to Connect (PTC) elbow 1/8 NPT

2940-338 3/8 Push Connect Tee-----→



←-----2940-341 Air Tubing Cutter

2940-342 Ball Valve-----→



←-----2940-345 Black 3/8 Air Tubing 100ft rolls

2940-346 Blue 3/8 Air Tubing 100ft rolls-----→



←-----2940-352 3/8 PTC Plug (package of 5)

2940-357 Extreme Air Magnum Rebuild Kit-----→



←-----2940-358 3/8 PTC Union, Straight

2940-367 25ft Roll 250psi Working Pressure Tubing--→



←-----2940-374 Tee-1)1/4"NPT male, 2)1/4"NPT female

2940-376 Updated Water Separator Drain Valve Kit--→



←-----2940-377 Hydraulic Compressor Pressure Switch

2940-379 PQE Inlet Elbow 1/4 NPT to 3/8PTC-----→



←-----2940-380 3/8PTC X 1/8BSPP O-ring Straight Fitting

2940-381 3/8PTC X 1/8BSPP O-ring Elbow Fitting---→



←-----2940-382 Shop Air Adapter

2940-383 3/8 PC WYE Fitting-----→



←-----2940-390 Extreme Air Magnum Compressor & Filter

2940-391 100 AMP Compressor Relay, Continuous--→



←-----2940-392 1-Way Check Valve

2940-395 Replacement Filter Element (Electric)-----→





























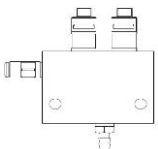

←-----2940-404 Pressure Regulator (part of the 2940-415)

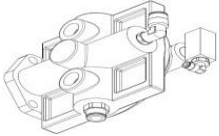
2940-408 3/8PTC Elbow Fitting 1/4NPT-----→

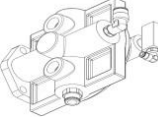

←-----2940-414 3/8PTC X 1/4NPT Straight Fitting

Components, Kits, Accessories, & Ordering Numbers

	2940-415	Water Separator/Regulator Assembly----->	
	<-----2940-416	175PSI Tank Safety Relief Valve	
	2940-430A	20 ft. Aux to Air Harness Extension----->	
	<-----2940-439	0 - 160psi Hydraulic Compressor Gauge	
	2940-441A	Pressure Transducer----->	
	<-----2940-506	Hyd. Comp. Solenoid Coil Only	
	2940-519A	Hydraulic Compressor Fan, CAST----->	
	<-----2940-531	Rubber Spider Insert for Love Joy Coupler	
	2940-543	Hyd. Comp. Cartridge Valve (no solenoid)----->	
	<-----2940-544	Hyd. Pressure Gauge (0 - 5000psi)	
	2940-545	Rol-Air Compressor Pump Unit----->	
	<-----2940-546	Hydraulic Control Block	
	2940-547	Hyd. Compressor Gasket Kit----->	
	<-----2940-636	Hydraulic Motor Seal Kit (GRH)	
	2940-549	Hydraulic Compressor Air Filter----->	
	<-----2940-550	Rol-Air Synthetic Compressor Oil 1Liter	
	2940-554	Hyd. Comp. Motor----->	
	2940-635	3/8 PTC X 3/8 NPT 90 Degree Swivel ----->	
	<-----2940-637	Valve Assembly	
	2940-638	Inlet Assembly ----->	
	<-----2940-639	Quick Exhaust Assembly (fittings included)	
	2940-640	Mac BV Valve 2-Way----->	
	<-----2940-641	10-32 to 1/4" Tube Barb Fitting	
	2940-642	10-32 to 5/32" Tube PTC Fitting----->	
	<-----2940-643	1/4" Tube Orifice	
	2940-644	1/4" NPT Tee ----->	
	<-----2940-645	Pilot Operated Regulator (fittings not included)	
	2940-646	1/4"NPT Street Elbow----->	

Components, Kits, Accessories, & Ordering Numbers

 ←-----2940-647 1/4" NTP to 5/32" Run Tee

2940-648 1/4" NPT Bulkhead -----→ 

 ←-----2940-649 1/4" NPT to 3/8" Run Tee

2940-650 1/4" NPT to 1/4" Tube PTC Elbow Fitting----→ 

 ←-----2940-651 5/32" Tubing

2940-652 12" X 14" X 8" Enclosure -----→ 

 ←-----1200-337 1/4" Airline, 100ft roll

2940-654 Thrasher to Midac Harness-----→ 

 ←-----2940-655 Control Box ISOBUS Harness

2940-656 ISOBUS Hitch Harness-----→ 

 ←-----2940-657 ISOBUS Extension Harness, 15ft

2940-658 ISOBUS Extension Harness, 30ft 

2940-659 JD ISOBUS Adapter Harness-----→ 

 ←-----2940-660 Terminator Harness

2966-910 RH RM Assembly, Less Blade-----→ 

 ←-----2966-911 LH RM Assembly, Less Blade

2966-905 Air Cylinder-----→ 

 ←-----2966-140-ST-FW RH ST FW Wheel Assembly

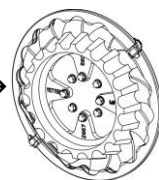
2966-141-ST-FW LH ST FW Wheel Assembly-----→ 

 ←-----2940-136 Dump Valve Kit

2940-154 30' Dump Valve Cable, Black-----→ 

2940-156 15' Dump Valve Cable, Black

←-----2940-158 15' Dump Valve Cable, Black

2940-161 5' Dump Valve Cable, Black

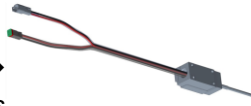
2940-197 Lift Switch-----→ 

 ←-----2940-676 15' Thrasher to Midac Ext. Harness

Introduction

The Yetter Air Compressor converts hydraulic or electric power into compressed air. Yetter Compressor units are durably constructed and designed for easy integration to operate the Yetter 2940 Air Adjust System. The Yetter Air Compressors build 145psi, the 2940-415 Water Separator/Regulator assembly allows 100-120psi of clean, dry air to enter the 2940-103A Control Box & as the operator commands pressure on the cab controller, the row cleaners adjust on the go with no planting delay or downtime leading to more planting hours per day. The precise adjustments give the row units & planter a more even ride leading to more accurate seed placement & seed depth resulting in even emergence. **IF USING THE YETTER COMPRESSOR TO SUPPLY AIR TO OPERATE ANOTHER PNEUMATIC SYSTEM, INSTALL A REGULATOR PRIOR TO AIR ENTERING THAT SYSTEM WITH THE PROPER REGULATED AIR SETTINGS RECOMMENDED BY THE OEM PRODUCT.**

System Requirements

Hydraulic Compressor

- Requires 4 gallons per minute maximum hydraulic flow to operate. 12CFM @ startup, 8.1CFM @ 90psi. 12 gallon storage tank.
- Lubrication of the pump requires a FULL synthetic or PAO synthetic compressor oil. **THE PUMP IS SHIPPED EMPTY & NEEDS OIL BEFORE OPERATING! SEE PAGE 22 FOR FILLING DETAILS!**
- Hydraulic oil flow is required to operate the hydraulic compressor's hydraulic motor. Different variables will determine the best way to connect into a hydraulic circuit to power the hydraulic motor. Connecting directly to a tractor's open SCV port, teeing into the planter frame lift/lowering circuit, or teeing into the bulk tank blower circuit are examples of supplying hydraulic flow to the compressor. Check OEM tractor and planter manual for hydraulic GPM output to make sure an adequate source is selected. If plumbing into a planter circuit, plumb between the tractor SCV and the hydraulic block usually located under the bulk fill tanks. The planter circuit that is plumbed into must have constant hydraulic flow. **PTO DRIVEN AND POWER BEYOND HYDRAULIC CIRCUITS ARE NOT AN ADEQUATE SOURCE TO OPERATE THE YETTER HYDRAULIC COMPRESSOR!**
- Case Drain connection is required to carry the motor case internal leakage directly to the tractor hydraulic reservoir (sump) with zero pressure. This oil serves to lubricate and cool motor components not directly exposed to the working oil. It is normal to have seepage from this fitting when disconnected from the tractor to protect the motor seals from thermal expansion. Plumb the case drain so that hydraulic oil returns to the same reservoir used for the pressure and return. If the tractor is not equipped with a female flat face case drain coupler, then a Case Drain Kit must be sourced through a dealer or hydraulic supplier. **DO NOT PLUMB THE CASE DRAIN OF THE HYDRAULIC COMPRESSOR INTO A RETURN CIRCUIT!**

Electric Compressor

- Uses 12V from tractor battery that has an implemented 80A breaker & 4 gauge power cables. **NO MORE THAN 50FT OF POWER CABLES SHOULD BE USED UNLESS LARGER GAUGE CABLES ARE MADE.** Low voltage detection is integrated in the Yetter system.
- 6CFM @ 0psi, 2.6CFM @ 100psi. 12 gallon storage tank.
- **OEM ELECTRIC COMPRESSORS ON PLANTERS ARE NOT AN ADEQUATE SOURCE OF AIR TO OPERATE THE YETTER 2940 AIR ADJUST SYSTEM!**

Power Supply

The 2940-103A Control Box uses the tractor's switched power source & battery power. Battery power cables are 8 gauge & a 40A breaker is implemented. The 2940-153A will need connected to a switched power source. **THE CIGARETTE LIGHTER POWER SOURCE IS NOT A SWITCHED POWER SOURCE AND SHOULD NOT BE USED!**

SWITCHED POWER SOURCE CONNECTOR PART #'S: (Connector to the tractor not included)

JOHN DEERE P/N: RE67013

CNH P/N: 187103A1

CAT P/N: AG233356

The 2940-112A VDM (Valve Drive Module) inside the 2940-103A Control Box uses 12V from the tractor battery.

Fuse Protection

To protect the VDM inside of the 2940-103A Control Box from damage always ensure the integrity of the integrated 40 amp breaker on the 2940-166 where connected to the tractor battery in case of short or over-circuit. Electric Compressors also use an additional 80 amp breaker. When connected correctly, the tractor has a fuse to protect switched power supply, located in the tractor's fuse panel.

Compressor Maintenance

To prolong life expectancy of Yetter compressors or OEM hyd. compressors, clean filter **DAILY** during use by removing element from filter housing, & tapping it, exposed side down. This will empty the pleats of filter of collected dust. If dust has been wet or won't clean out, order a new element, part # 2940-549 for hyd. compressors & 2940-395 for electric compressors, or if using an OEM hydraulic compressor, call your local dealer. You may lightly blow out the compressor housing using a blow gun, however, **DO NOT** blow out filter element. The housing & filter should be cleaned **DAILY** during field operation, or more if conditions are very dusty. Hydraulic compressors create a good amount of moisture & should be drained **DAILY** when in use. **See pages 38 – 39 for further maintenance.**

2940 Air Adjust System Information

The 2940 Air Adjust Residue Manager control system consists of six primary components and kits; 2966-004 Residue Manager(RM) Kit, Tablet or ISOBUS controller, Yetter Air Compressor Assembly (unless plumbing into an OEM hydraulic compressor), Control Box Kit, Harnessing/Air Lines/Fittings Kit, & the Lift Switch Kit.

Residue Manager

Each of these kits will include the required brackets, wheel assemblies, & mounting hardware for installation to the row unit.

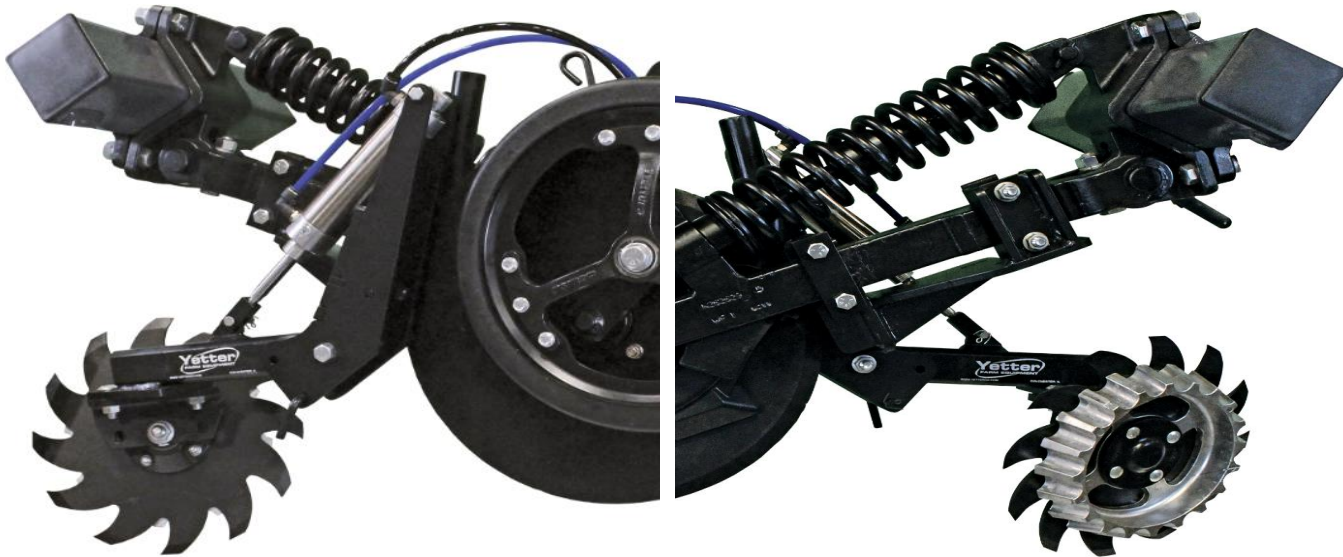

Tablet (NOT SUPPLIED)

The Tablet of choice, not supplied, will use the 2940-111 RAM mount for 9 – 10” tablets provided for installation in cab. If a larger Tablet size is used, sourcing a larger RAM Tablet Mount will be necessary. RAM-HOL-UN11U can be purchased online for tablets 11 – 12”. Go into the tablets App Store, search for Yetter Air Adjust, & download the App. Once the system is installed, turn the key to make sure the 2940-653 Thrasher module’s indicator lights come on. Once the indicator lights are on, go into the tablets WiFi settings & connect to AIR ADJUST using password **12345678**. Open the Yetter App & you should be taken to the Activation Screen. Press the ACTIVATE SYSTEM icon & you will be taken to the operating screen. Until the compressor has built a minimum of 75psi, no pressure will be sent to the air bags. Let the compressor go thru 1 complete cycle & shut off before applying air to the air bags. Using shop air with the 2940-382 adapter is an alternative method way to supply air to the system to help prolong the service life on Yetter compressors.

RAM Mount



Tablet Operating Screen



2940 Air Adjust System Information

Air Compressor Assembly



2940 Air Adjust requires a stable air supply source that can provide a minimum of 75psi of clean, dry air. The 'clean, dry air' is a key component of the air supply, moisture within the air supply can shorten the life cycle of the system. Yetter compressors should build to 145psi on the tank gauge before shutting off. When pressure in the tank drops below 120psi, the compressor will engage to build back up to 145psi. Other pneumatic systems, for example pneumatic down force or air clutches, can be plumbed using the Yetter compressor as its air source. Be sure to regulate the air entering any other systems to OEM specifications.



Electric Compresso External Diagram

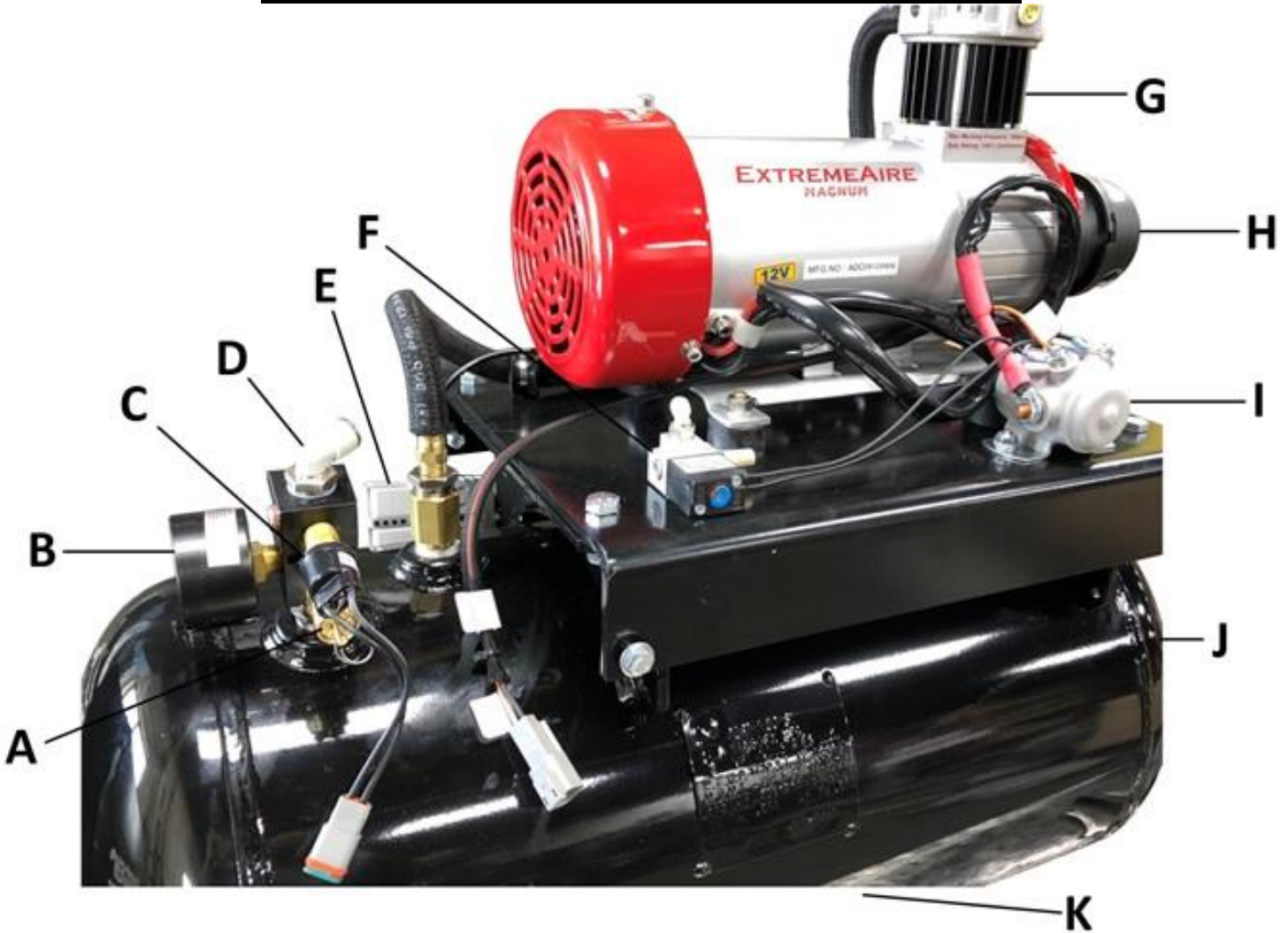

- A – 2940-416 175psi Safety Relief Valve
- B – 2940-439 0 – 160psi Compressor Gauge
- C - 2940-377 Pressure Switch 125psi – 145psi
- D – 2940-635 3/8"PTC X 3/8NPT 90° Fitting
- E – No Part # Main Power Connector
- F – 2940-336 Head Pressure Relief Valve

- G – 2940-390 Electric Air Compressor
- H – 2940-395 Replacement Filter Element
- I – 2940-391 100 Amp Compressor Relay
- J – 2940-440 12G Tank Assembly
- K – No Part # Tank Drain Valve
- Not shown** – No part # Enclosure Cage

Hydraulic Compressor External Diagram

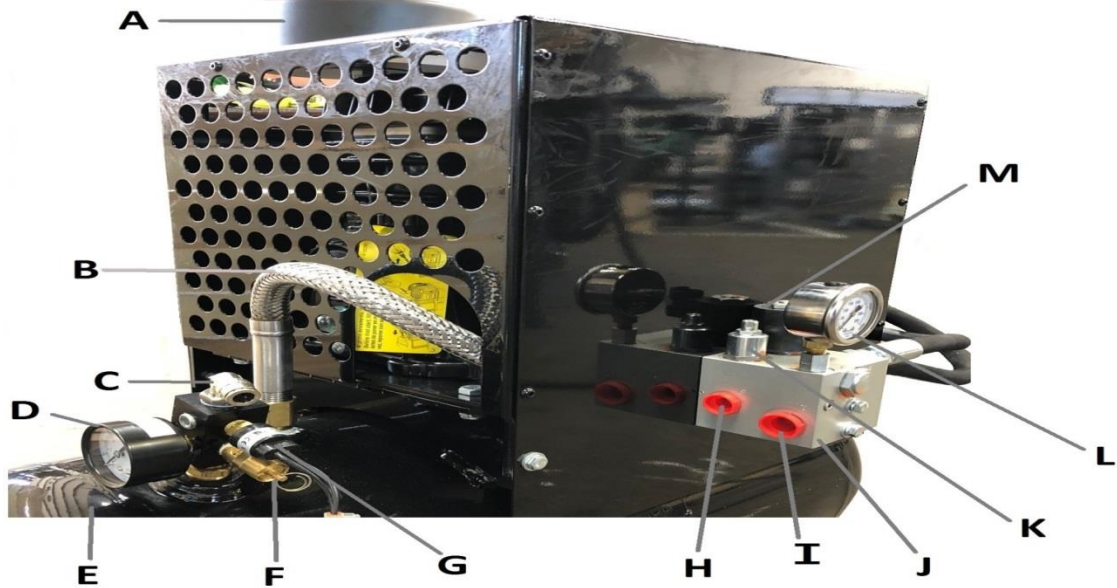

Item	Part Number	Description	Quantity
A	2940-549	Air Filter	1
B	N/A	Compressor Pressure Line	1
C	2940-635	Output Elbow Fitting 3/8PTC 90 Degree 3/8NPT	1
D	2940-439	Tank Pressure Gauge	1
E	2940-440	Tank, 12 Gallon	1
F	2940-416	Safety Relief Valve	1
G	2940-377	Pressure Switch, 125PSI – 145PSI	1
H	N/A	Hydraulic Pressure Port -6 ORFS	1
I	N/A	Hydraulic Return to Tank Inlet Port -6 ORFS	1
J	2940-546	Hydraulic Compressor Control Block	1
K	N/A	Flow Control Valve	1
L	2940-544	0-5000PSI Hydraulic Pressure Gauge	1
M	2940-506	Hydraulic On/Off Valve (COIL ONLY)	1
	2940-543	Hydraulic On/Off Cartridge Valve	1

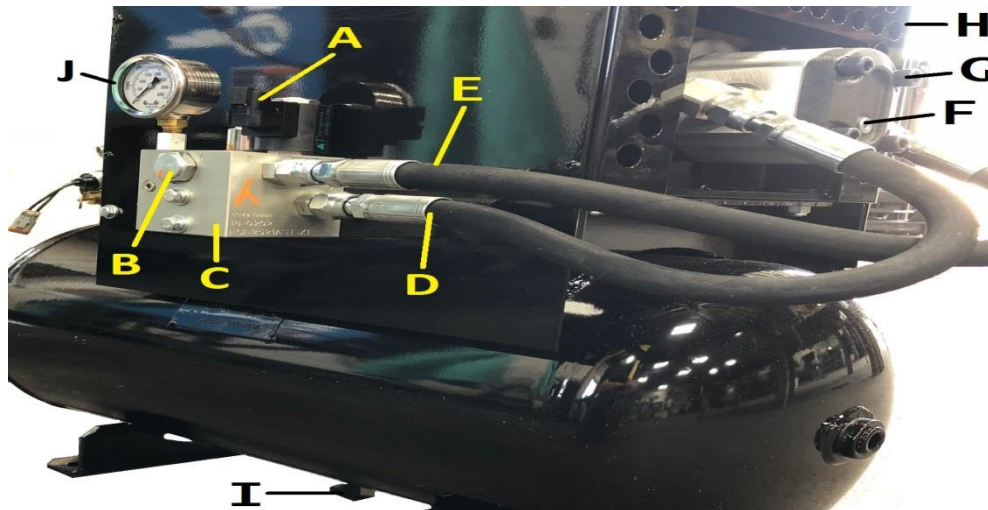

Item	Part #	Description	Quantity
A	2940-506	Hydraulic Compressor Solenoid Coil	1
	2940-543	Hydraulic On/Off Valve (Solenoid)	
B	N/A	Check Valve	1
C	2940-546	Hydraulic Compressor Control Block	1
D	N/A	Pressure Inlet Hose	1
E	N/A	Return to Tank Hose	1
F	N/A	Case Drain Port -4 ORFS	1
G	2940-554	Hydraulic Motor	1
H	N/A	Housing Assembly	1
I	N/A	Tank Drain Valve	1
J	2940-554	Hydraulic Pressure Gauge	1

Control Box

The 2940-103A control box communicates between the 2940-112A VDM & 2940-653 Thrasher, dispenses air out of quick exhaust regs that are fed by little fill/dump valves as the operator sends commands. The VDM is the valve drive module that is programmed to carry out each function of the system. The Thrasher uses a WiFi signal or ISOBUS to communicate commands by the operator to execute thru the VDM.

2940-103A Control Box External Lay Out

2940-654 – MIDAC TO THRASHER
COMMUNICATION HARNESS

2940-653 – JCA THRASHER MODULE
(MOUNTED ON TOP OF THE BOX)

POWER
HARNESS
CONNECTOR

ISOBUS
CONNECTION

COMPRESSOR
COMMUNICATION

THRASHER TO
VDM
CONNECTOR

2940-408
AIR SUPPLY
INLET ELBOW



WATER
SEPARATOR
OUTLET

WATER
SEPARATOR
INLET

RU – ALL ROWS
UPPRESSURE

RD – WING ROWS
DOWN PRESSURE

WT – CENTER ROWS
DOWN PRESSURE

WHEEL TRACK (WT) DOWN PRESSURE PORT - Safely route black airline from the WT port to the tee in the center section of the planter's down pressure trunk airline. The down pressure on the center section residue managers (RM) or RM/Coulter Combo can be adjusted separately than the wing/outer sections down pressure to make up for tractor/planter tire compaction. WT should be set 2-5 psi heavier than RD. If the WT port is not used, install a plug (2940-352) to prevent air loss.

RESIDUE MANAGER DOWN (RD) PRESSURE PORT - Safely route black airline from the RD port to the open port on each tee installed in the trunk airline on each wing/outer sections of the planter. This port dispenses down pressure to the RM or RM/Coulter Combos on the wing/side of the planter.

RESIDUE MANAGER UP (RU) PRESSURE PORT - Safely route blue airline from the RU port to each tee on each section of the planter's up pressure trunk airline. This port dispenses up pressure to each RM or RM/Coulter Combo on the planter.

WATER SEPARATOR INLET- Install the 1/4" airline from the bottom of the water separator into this port.

WATER SEPARATOR OUTLET- Install 1/4" airline in this port, route toward the ground. (drain's condensation from water separator)

MAIN AIR SUPPLY INLET- Plumb the 2940-367 250psi rated 3/8" airline from the hydraulic compressor to the inlet (water trap side) of the water separator/regulator assembly. Plumb 2940-345 3/8" black airline from outlet (regulator side) of the water separator/regulator assembly to this port. Ensure the regulator is set to 100-120psi by reading the gauge.

COMPRESSOR COMMUNICATION – Install the 2940-181 Compressor Solenoid/Switch Harness at the compressor. Use 2940-182 (20FT) &/or 2940-189 (10FT) extension harnesses to reach the control box & install into this port. Used only if application uses a Yetter Hydraulic Compressor. **(see page 24)**

POWER HARNESS CONNECTION - Depending on application, route 2940-164A or 2940-165A AUX PWR cable from rear of the tractor to this female connector. If the control box is mounted at the rear of the planter, 2940-170A, 2940-171A, or 2940-430A AUX PWR extensions will route to this female connector.

2940-654 MIDAC TO THRASHER HARNESS – Connects the communication/power supply from the Midac to the Thrasher

2940-103A Control Box Internal Lay Out

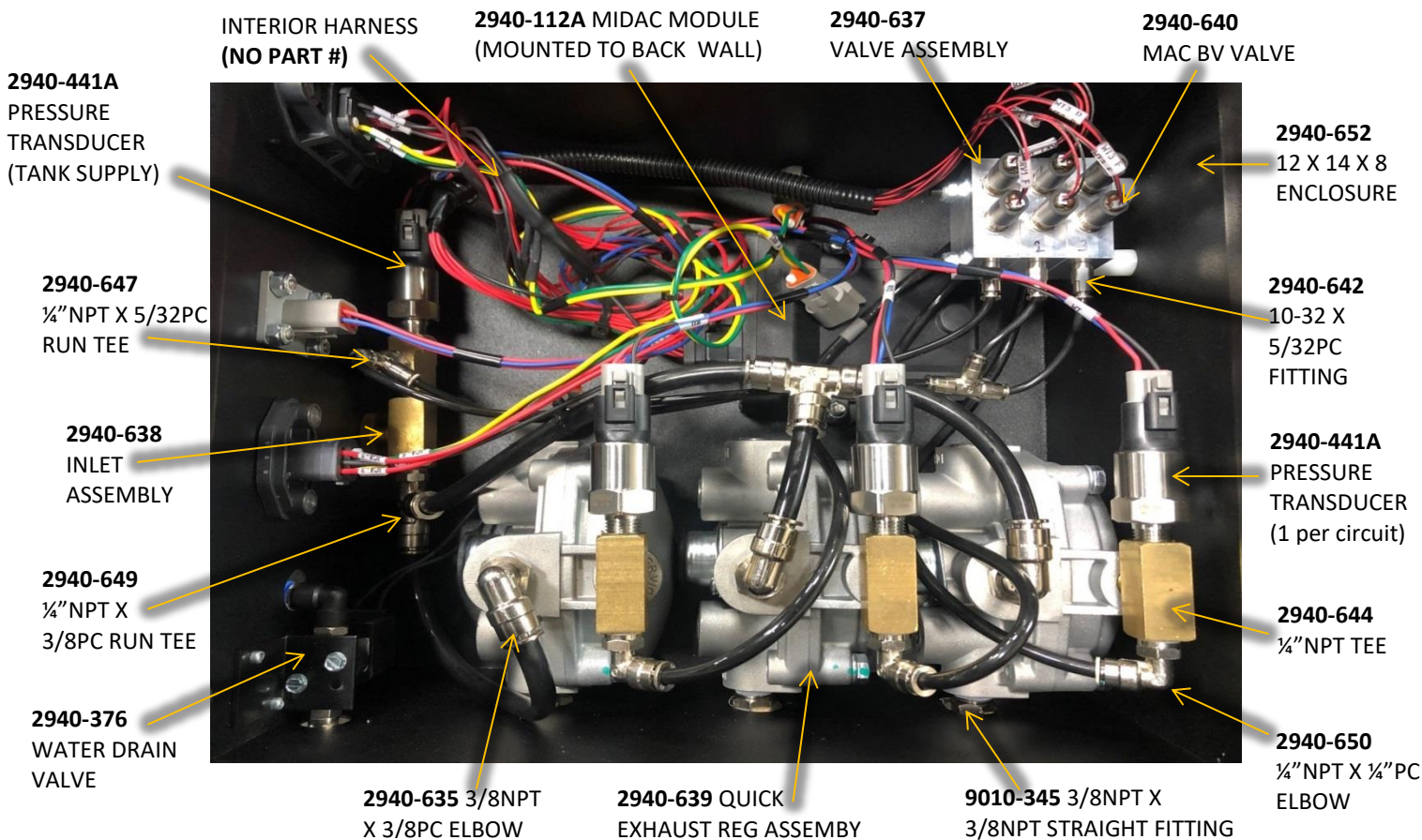

AIR TUBING: 2940-345 3/8 AIRLINE, 100FT ROLL, 1200-337 1/4 AIRLINE, 100FT ROLL, 2940-651 5/32 AIRLINE, 100FT ROLL

Harness, Airlines, and Fittings Kit



12V-DC cables will be used to power the VDM & Thrasher. Flexible tubing will be used to move air from tank to each air bag. Each kit will include pneumatic lines for both circuits, down & lift, as well as the fittings to make connections & cable ties to securely fasten the lines to seeder. Note: All 2940 Air Adjust kits include a tubing cutter within the kit. **The 2940-341 airline cutter should be used for every cut to ensure a clean, square cut is made.**

2966-050 Lift Switch Kit



The Lift Switch Kit is what is used to raise the residue managers to the raised position whenever the seeding units are raised. This prohibits the wheel assemblies from galging into the surface & causing damage to the RMs, soil, & already planted seed. A minimum of 3 dump valves need installed in each section of the seeder in the down pressure circuit of the RM trunk airline. Switched 12V power will be sent to the limit switch, the switch will be wired normally open, & when triggered, will close sending power to the dump valves dumping the down pressure on each section & raise the RMs.

Installation Guide Using a Yetter Compressor

***For installation using a John Deere Hydraulic Compressor installation, [see page 17](#)**

STEP 1: RESIDUE MANAGER (RM) INSTALLATION

Residue Manager Only: Install RM Assemblies securing with mounting hardware & mount straps. Install the RM wheels on wheel mounts using the 5/8 Whiz Lock Nut. [Refer to diagram on pages 18](#)

STEP 2: TABLET/ISOBUS IN-CAB INSTALLATION

If using a tablet, mount Tablet & 2940-111 RAM Mount in tractor cab. Position Tablet within reach during operation without compromising safety/visibility from cab. The right rear corner post area is recommended so that operator can see performance of residue managers while making adjustments. In both applications, install 2940-153A harness by feeding the bare ends thru the harness access hole into the cab. Bare ends get spliced to plug (not provided) that fits tractor's switched power source, splice red wire on 2940-153A to orange wire & splice black wires together on each harness. Leave the 2 pin connector at the tractor hitch. [Refer to diagram on page 19](#)

STEP 3: COMPRESSOR & CONTROL BOX INSTALLATION

Control Box Installation: Mount the control box in a safe location with mounts/hardware supplied where the control box can be viewed from the tractor cab. Install the 2940-415 water separator/regulator assembly near the control box. Measure & cut the 2940-367 250psi rated 3/8" airline & install from outlet elbow on the compressor into the 2940-415 inlet (water trap side). Adjust the regulator to allow 100-120psi of air into inlet of control box. Install 3/8" airline from 2940-415 outlet fitting (regulator side) to control box 3/8 inlet fitting. Route provided 1/4" airline from elbow on bottom of 2940-415 to 1/4"PTC fitting on bottom of control box. Route 1/4" airline from 1/4"PTC fitting on the side of control box toward the ground, as airline will dispense moisture. [Refer to diagram on pages 20, 24, & 26](#)

Compressor Installation: Remove compressor from shipping crate. On Hyd. Compressors, remove the control block & housing to add provided oil to fill line on sight glass of the Rol-Air pump. Reinstall housing & control block after filling with oil. Locate a suitable mounting location for the compressor assembly. Placement of the compressor assembly will vary on the make & model of the seeder. Use mounts & hardware supplied or depending on application, [different mounts may need to be built](#). Be sure to check clearance of the compressor in the mounting location, noting tractor tires while making turns, markers, & folding/unfolding the seeder. [Refer to diagram on pages 22 – 26](#)

STEP 4: COMPRESSOR & CONTROL BOX HARNESS INSTALLATION

Only on Yetter electric compressor installation, install 2940-150 main power cable/breaker (4 gauge cable, 80A breaker) on tractor battery on the correct terminals, red = positive +, black = negative -. Install 2940-151(10ft) & 2940-163(20ft) power cable extensions as needed between the main power cable/breaker & main power connector on the electric compressor. On all installations, install the 2940-166 VDM power cable with 40A breaker on the tractor battery on the correct terminals, red = positive +, black = negative -. Connect the VDM power extension (2940-167 or 2940-168) & route to the tractor hitch. Install the AUX PWR Harness, 2940-164A or 2940-165A. The 2 pin connects to the 2940-153A from the tractor cab, the Anderson power connector connects to the 8 gauge cable that routes to the battery, & the black male 12 pin Deutsch connector connects to power harness connector on the side of the control box. If the 2940-103A control box is mounted further back on the seeder, 2940-170A (10ft), 2940-171A (30ft), & 2940-430A (20ft) AUX PWR extensions will be needed. Install the 2940-181 Y harness on the Yetter compressor. Install the 2940-182 or 2940-189 control harness from the 4 pin end of the 2940-181 Y harness to the 4 pin connector on the side of the control box. [Refer to diagram on page 19, 23 – 24](#)

ISOBUS HARNESS (IF APPLICABLE) Install 2940-655 harness to 2940-654 on Yetter control box. Use 2940-657(15ft) & 2940-658(30ft) extensions to reach where ISOBUS is being tied in. On JD seeders (new N series seeders), use the 2940-659 to plug in at back of seeder where terminating resistor harness was located. [Refer to diagram on page 21](#)

STEP 5: LIFT SWITCH / DUMP VALVE KIT INSTALLATION

Install a minimum of 3 Dump Valves centrally located on each section of the seeder. Install the Lift Switch on the seeder so that when in the planting position, the switch is open & not tripped. When the seed units are raised, the lift switch needs to trip (closed) sending power to the dump valves which will close off the down pressure supply & drain the down pressure in all RM down pressure. Install a 2940-158 Y harness at the hitch of the tractor on the 2 pin connector of the 2940-153A that goes to the tractor cab to get switched power. Install 15ft or 30ft extensions to reach the Lift Switch & install into 1 of the connectors on the Lift Switch. From the other connector on the Lift Switch, install 5ft, 15ft, & 30ft extensions & Y harnesses to the dump valves on each section of the seeder. [Refer to diagram on page 27](#)

STEP 6: PLUMBING AIRLINES

A group of airlines that route to RM cylinder are referred to as trunk airlines. Airline routing from RU, RD, & WT to trunk airline is referred to as supply airline. Start by routing trunk airlines: route black (down pressure) & blue (up pressure) airline on each wing/side of seeder. Start at end row of each wing, route airline to last row on wing & install in cylinder, black airline = down pressure (top side), blue airline = up pressure (rod end). Follow airline back to end row cutting a tee in each airline at each row. When return back to end row, cut airline to length & install into air cylinder. Install airline from each tee at each row & install in air cylinder for that row. When plumbing in WT (wheel track) rows, use center section seed rows to control the down pressure on this section separately than down pressure on wings. Install a tee in the center of each up pressure trunk airline. Use tees to route/install blue airline from the RU port on control box to each tee in center of each up pressure trunk airline. Install a tee into the down pressure trunk airline on the left wing & right wing. Route/install black airline from the RD port on control box to the center port of each Dump Valve on each wing. Install black airline from port 2 on dump valve & tee into the closest sport on down pressure airline on same wing. Install 3 tees in center of center section down pressure trunk airline. Route/install airline from WT port on control box to center port of Dump Valves on center section of seeder. Install black airline from tees in the center of down pressure trunk airline on center of planter to port 2 of the Dump Valves on the center section of seeder. If seeder is dual rank tee the up pressure trunk airlines together & down pressure trunk airlines together on each section. [Refer to pages 28 – 30](#)

STEP 7: PERFORM A PRE-OPERATION TEST OF THE SYSTEM

Now that the system is installed, perform a pre-operation test. Start by folding/unfolding & lowering/raising the seeder checking for slack in airline & in harnesses at hinge points. Check all electrical connections, cables, & airline making sure nothing was damaged. Next, with the tractor on, connect to the WiFi with your tablet or pull the Yetter screen up on the ISOBUS VT, & press the ACTIVE SYSTEM icon. The compressor will turn on, build to 145psi (100-120psi on the cab controller) & shut off. Check the interior of the control box housing (valve, fittings, & airline) for leaks. Apply 40psi to the RU port & watch your RMs as they should all raise to maximum up travel. Check for leaks on all up pressure circuits & fittings. When that leak check is finished, turn RU to 0psi & turn RD & WT to 40psi. Check all down pressure airline & fittings in these circuits for leaks & repair as needed. [Refer to pages 36 – 37](#)

***Installation Guide – John Deere Hydraulic Compressor**

STEP 1: RESIDUE MANAGER (RM) INSTALLATION

Residue Manager Only: Install RM Assemblies securing with mounting hardware & mount straps. Install the RM wheels on the wheel mounts using the 5/8 Whiz Lock Nut. **Refer to diagram on pages 18**

STEP 2: TABLET/ISOBUS IN-CAB INSTALLATION

If using a tablet, mount Tablet & 2940-111 RAM Mount in tractor cab. Position Tablet within reach during operation without compromising safety/visibility from cab. The right rear corner post area is recommended so that operator can see performance of residue managers while making adjustments. In both applications, install 2940-153A harness by feeding the bare ends thru the harness access hole into the cab. Bare ends get spliced to plug (not provided) that fits tractor's switched power source, splice red wire on 2940-153A to orange wire & splice black wires together on each harness. Leave the 2 pin connector at the tractor hitch. **Refer to diagram on page 19**

STEP 3: 2940-103A CONTROL BOX INSTALLATION

Mount the control box in a safe location (usually on handrail) with mounts & hardware supplied. Locate the John Deere hydraulic compressor & its pneumatic valve block assembly. Drain all air pressure from the compressor tank & valve block. Locate the plug (next to the yellow valve handle or pressure gauge facing rearward on the valve manifold. Remove the pipe plug if equipped & install a 2940-408 1/4"NPT X 3/8PC elbow in that port. If equipped with a gauge, remove gauge & install 2940-374 adaptor with 2 female 1/4"NPT ends & 1 male 1/4"NPT end. Male thread side of Tee installs into valve block, gauge installs onto rearward facing female threads, & 2940-408 elbow installs into remaining female threads (facing upward). Apply Teflon tape to all male threads. Mount the 2940-415 water separator/regulator assembly near control box. Measure & cut 2940-367 250psi rated line from the 2940-408 elbow attached to valve block into the inlet (water trap side) of water separator regulator assembly. Adjust the regulator to only allow 100-120psi of clean, dry air beyond it. Measure & cut black airline from the outlet fitting (regulator side) of water separator/regulator assembly to 3/8 inlet fitting of control box. Route provided 1/4" airline from elbow on the bottom of water separator/regulator assembly to 1/4"PC fitting on the bottom of control box. Route 1/4" airline from 1/4"PTC fitting on the side of control box toward the ground, this airline will dispense moisture. **Refer to diagram on pages 20 & 26**

STEP 4: CONTROL BOX HARNESS INSTALLATION)

Install 2940-166 VDM power cable with 40A breaker on tractor battery on the correct terminals, red = positive +, black = negative -. Connect VDM power extension (2940-167 or 2940-168) & route to tractor hitch. Install the AUX PWR Harness, 2940-164A or 2940-165A. The 2 pin connects to the 2940-153A from tractor cab, Anderson power connector connects to 8 gauge cable that routes to battery, & black male 12 pin Deutsch connector connects to power harness connector on the side of the control box. If the 2940-103A control box is mounted at back of the seeder, 2940-170A(10ft), 2940-171A(30ft), & 2940-430A(20ft) AUX PWR extensions will be needed. **Refer to diagram on page 19**

ISOBUS HARNESS (IF APPLICABLE) Install the 2940-655 harness to 2940-654 on Yetter control box. Use 2940-657 (15ft) & 2940-658 (30ft) extensions to reach where the ISOBUS is being tied in. On JD seeders, use the 2940-659 to plug in at the back of planter where terminating resistor harness was located. **Refer to diagram on page 21**

STEP 5: LIFT SWITCH / DUMP VALVE KIT INSTALLATION

Install a minimum of 3 Dump Valves centrally located on each section of the seeder. Install the Lift Switch on the seeder so that when in the planting position, the switch is open & not tripped. When the seed units are raised, the lift switch needs to trip (closed) sending power to the dump valves which will close off the down pressure supply & drain the down pressure in all RM down pressure. Install a 2940-158 Y harness at the hitch of the tractor on the 2 pin connector of the 2940-153A that goes to the tractor cab to get switched power. Install 15ft or 30ft extensions to reach the Lift Switch & install into 1 of the connectors on the Lift Switch. From the other connector on the Lift Switch, install 5ft, 15ft, & 30ft extensions & Y harnesses to the dump valves on each section of the seeder. **Refer to diagram on page 27**

STEP 6: PLUMBING AIRLINES

A group of airlines that route to RM cylinder are referred to as trunk airlines. Airline routing from RU, RD, & WT to trunk airline is referred to as supply airline. Start by routing trunk airlines: route black (down pressure) & blue (up pressure) airline on each wing/side of seeder. Start at end row of each wing, route airline to last row on wing & install in cylinder, black airline = down pressure (top side), blue airline = up pressure (rod end). Follow airline back to end row cutting a tee in each airline at each row. When return back to end row, cut airline to length & install into air cylinder. Install airline from each tee at each row & install in air cylinder for that row. When plumbing in WT (wheel track) rows, use center section seed rows to control the down pressure on this section separately than down pressure on wings. Install a tee in the center of each up pressure trunk airline. Use tees to route/install blue airline from the RU port on control box to each tee in center of each up pressure trunk airline. Install a tee into the down pressure trunk airline on the left wing & right wing. Route/install black airline from the RD port on control box to the center port of each Dump Valve on each wing. Install black airline from port 2 on dump valve & tee into the closest sport on down pressure airline on same wing. Install 3 tees in center of center section down pressure trunk airline. Route/install airline from WT port on control box to center port of Dump Valves on center section of seeder. Install black airline from tees in the center of down pressure trunk airline on center of planter to port 2 of the Dump Valves on the center section of seeder. If seeder is dual rank tee the up pressure trunk airlines together & down pressure trunk airlines together on each section. **Refer to pages 28 – 30**

STEP 6: PERFORM A PRE-OPERATION TEST OF THE SYSTEM

Now that the system is installed, perform a pre-operation test. Start by folding/unfolding & lowering/raising the seeder checking for slack in airline & in harnesses at hinge points. Check all electrical connections, cables, & airline making sure nothing was damaged. Next, with the tractor on, connect to the WiFi with your tablet or pull the Yetter screen up on the ISOBUS VT, & press the ACTIVE SYSTEM icon. The compressor will turn on, build to 145psi (100-120psi on the cab controller) & shut off. Check the interior of the control box housing (valve, fittings, & airline) for leaks. Apply 40psi to the RU port & watch your RMs as they should all raise to maximum up travel. Check for leaks on all up pressure circuits & fittings. When that leak check is finished, turn RU to 0psi & turn RD & WT to 40psi. Check all down pressure airline & fittings in these circuits for leaks & repair as needed. **Refer to pages 36 – 37**

Residue Manager(RM) Installation

Installation overview:

- Prior to installation of each RM mounting bracket assembly, check the freedom of motion of the pivot arm.
- The installation process should be done with the row units fully extended down.
- Install the RM on the cast arm of each row unit, seed boots may need loosened to install the row cleaner, then retightened.
- Set Down Stop Pin in field
- LH RM assemblies mount to LH seed units, RH RM assemblies mount to RH seed units. LH RM assemblies will have RH wheel assembled on right side of wheel mount. LH seed units have gauge wheels on LH side of unit. RH RM assemblies will have LH wheel assembled on left side of wheel mount. RH seed units have gauge wheels on right side of seed unit.

LH Residue Manager Assembly

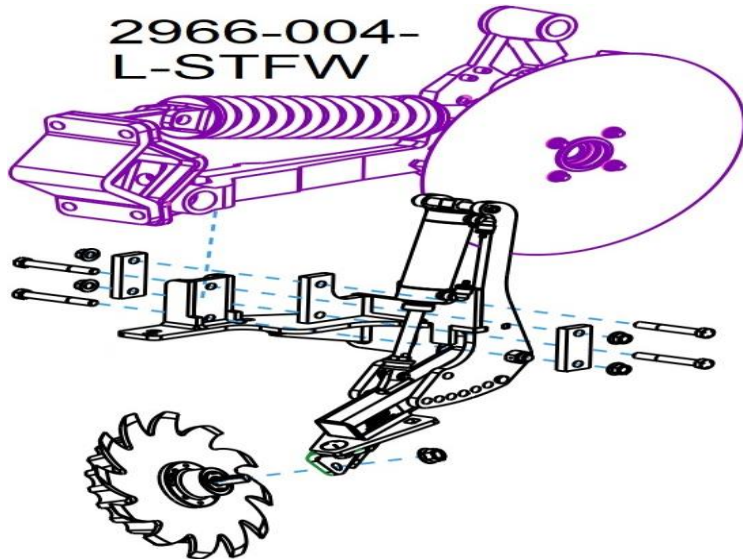

RH Residue Manager Assembly

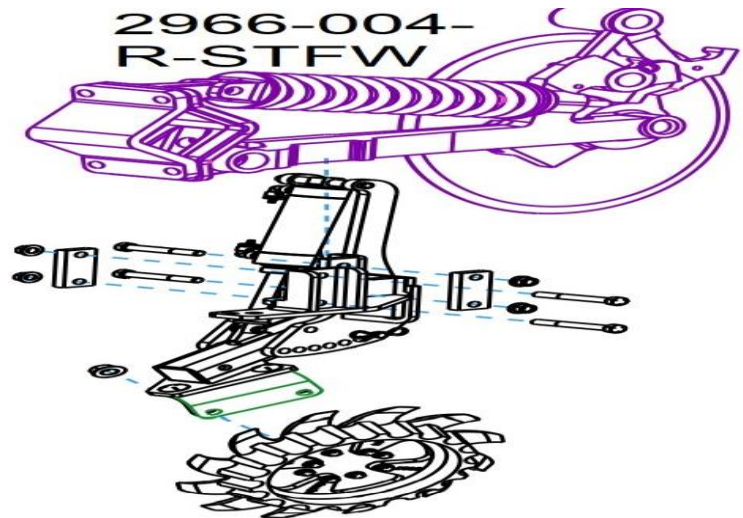

Step 1: Place 1) Pneumatic RM Assembly, 1) Mounting Hardware Bolt Bag, & 1) RH Wheel Assembly (2966-140) or 1) LH Wheel Assembly (2966-141) at each seeding row unit. Install Pneumatic RM assembly to cast arm using 2) 1/2" X 3 1/2" GR5 bolts, 2) 1/2" Whizlock nuts, & 1) 2966-436 Clamp Plate on rear mounting holes, use 2) 1/2" X 3 3/4" GR5 bolts, 2) 1/2" Whizlock nuts, & 1) 2966-436 Clamp Plate on front mounting holes. Install the Wheel Assembly using 1) 5/8" Whizlock Nut.

Tools needed: 3/4" socket, 3/4" wrench, 15/16" ratcheting wrench, & impact wrench



CAUTION: It is highly recommended to wear gloves when tightening wheels!

Tablet, Switched Power, & Main Power Installation

Skip Steps 1 & 2 if using ISOBUS monitor

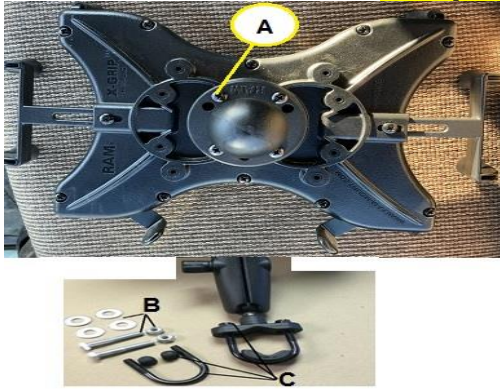

Step 1: Begin installing the 2940-111 once an adequate mounting location has been found. Fix the base component of the 2940-111 Mounting Bracket in place to the back of the Tablet Holder using 4 – screws (A). Use items labeled B if mounting to a slotted, flat mounting system & securely tighten the hardware. Use items C if using a tubular mounting system

Step 2: Attach the Double Socket Arm to Tablet Holder & Ball Base, tighten clamp by turning the handle clockwise.

Step 3: Locate the 2940-153A cable & route bare ends into tractor cab, connector end should be at the tractor hitch. Install the wire harness (**not provided**) for your tractor at the bare end of the 2940-153A & connect to tractors switched power source. Secure the black ground wires together & the red wire on the 2940-153A to the orange wire on the OEM harness. **Cigarette outlet is NOT a switched port on all models of tractors, and therefore should not be used.**



Switched Power Source Connector part #'s:

JOHN DEERE PART #: RE67013

CNH PART #: 187103A1

CAT P/N: AG233356

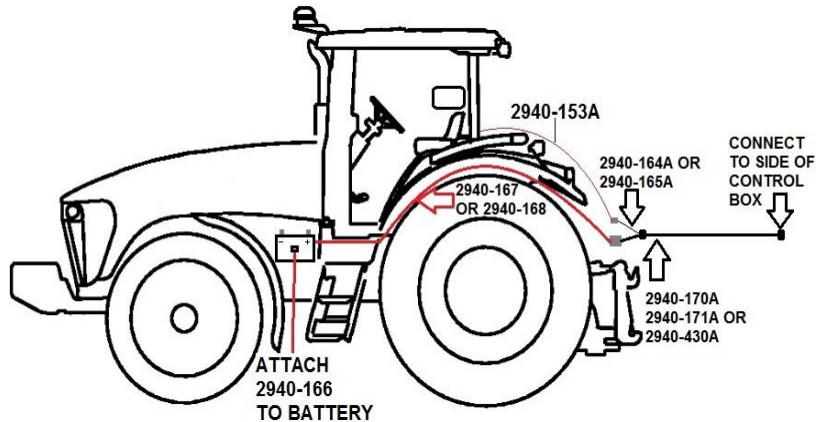
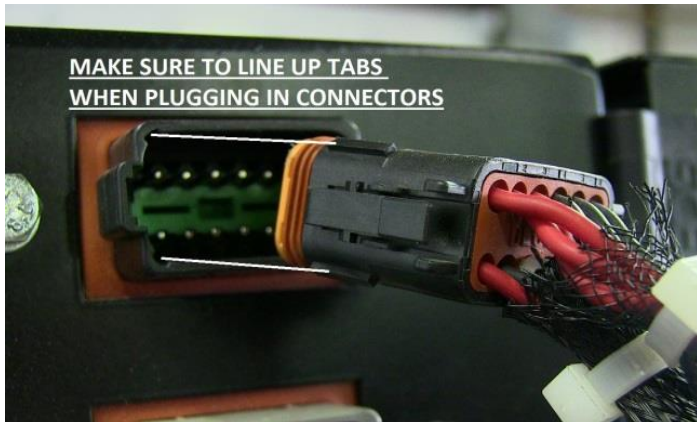

FAILURE TO LINE UP TABS WHEN PLUGGING MALE INTO FEMALE CONNECTORS CAN RESULT IN SHORT CIRCUIT. ALSO CHECK TAB & SLOT SIZES, PLUGGING CONNECTORS IN BACKWARDS WILL RESULT IN A FAULTY SYSTEM!!!

Step 4: Install 2940-166 VDM power cable/40A breaker on battery, red cable to positive (+) stud, black cable to negative (-) stud.

Step 5: Install the 2940-167 (10ft) or 2940-168 (20ft) VDM power extension cable to the 2940-166 & route to the hitch of the tractor.

Step 6: Install the 2940-164A (5ft) or 2940-165A (10ft) PWR to Air Harness. This harness has 3 ends. Install the Anderson power connector to power extension to battery from step 5, install 2 pin Duetsch to 2940-153A switched power harness from Step 3, & install the male black 12 pin Deutsch connector to female end on the side of control box. If the control box is mounted further back than the hitch of the seeder, PWR to Air Extension harnesses need to be installed. Use 2940-170A (10ft), 2940-171A (30ft), & 2940-430A (20ft) Extensions to reach to control box. On seeders, no harnesses should need installed inside frame tubes. Route harnesses on the top or side of the framework.

Step 7: Zip tie the cables/harnesses as needed to secure them to the seeder framework & out of harm's way.

2940-103A Control Box Installation

2940-103A Control Box is an assembled unit that utilizes compressed air supplied by the OEM hydraulic compressor to operate the 2940 Air Adjust System. In some situations, a mount may need to be built to install the 2940-103A in an adequate location.

OEM ELECTRIC COMPRESSORS ALREADY ONBOARD PLANTERS WILL NOT OPERATE YETTER 2940 AIR ADJUST SYSTEMS!
THE IMAGES BELOW CONTAIN THE 2940-103 CONTROL BOX MANUFACTURED FROM 2013 -2020.

2940-082 (See page 47 for diagram)



2940-083 (See page 47 for diagram)



2940-084 (handrail by steps)



(See page 47 for diagram of the 2940-084)

Once the 2940-103A Control Box is mounted, install the Aux Extension (black 12 pin Deutsch) that routes from the tractor hitch into the side of the Control Box from [page 19](#).

2940-415 Water Separator/Regulator Installation

Install the 2940-415 water separator/regulator assembly near the control box in a suitable location out of harm's way. The water separator removes moisture from entering the system's control box. Install the assembly with the water trap vertical & elbow fitting towards the ground. Adjust the regulator (2940-404) to only allow 100 – 120psi into the control box. Below are some examples of mounting locations for the water separator/regulator assembly.



2940-087A ISOBUS Installation – To Tractor Hitch Connector

- Step 1:** Install 2940-655 Yetter ISOBUS Y Harness at Yetter Control Box. Install triangular 3 pin connector on the 2940-655 to triangular 3 pin connector on the 2940-654 Yetter Control Harness.
- Step 2:** Install 2940-657 (15ft) or 2940-658 (30ft) extension harnesses to 2940-655 & route to ISOBUS connector on hitch of the tractor.
- Step 3:** Install 2940-656 ISOBUS Hitch Harness to 2940-657 or 2940-658 at tractor hitch. Plug other end of 2940-656 into tractors ISOBUS port on hitch.

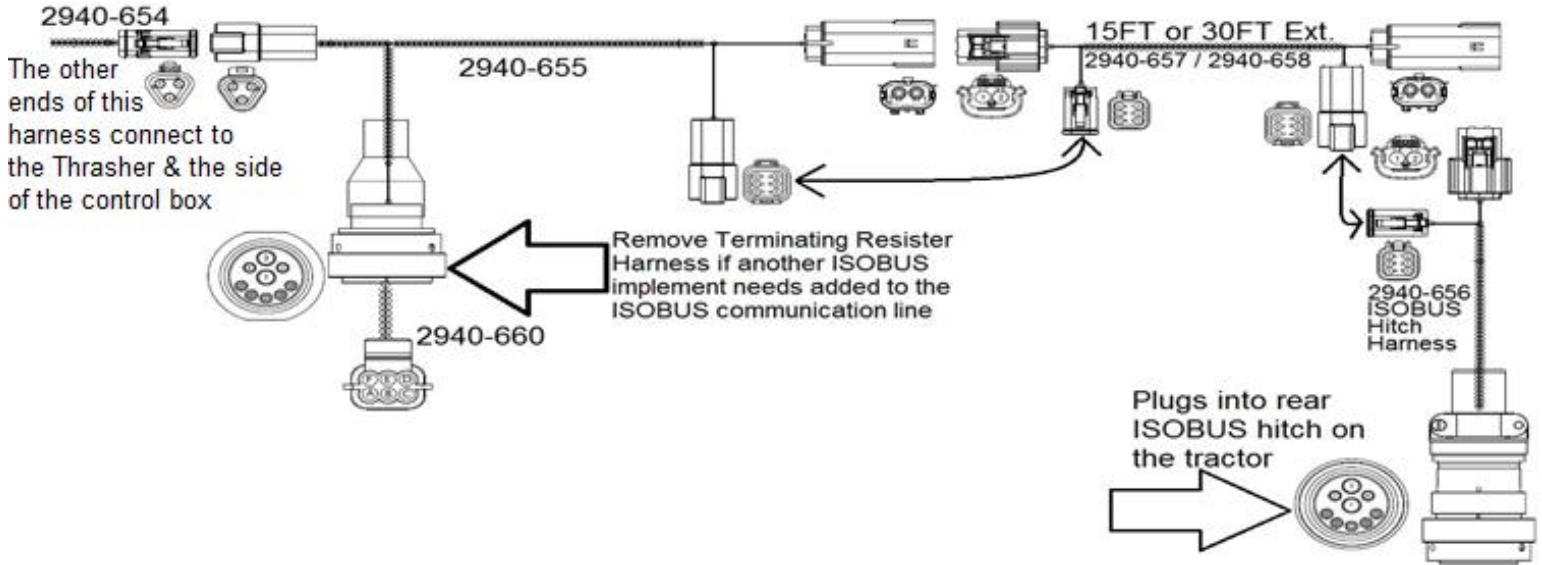

2940-087A-JD ISOBUS Installation – John Deere

- Step 1:** Install the 2940-655 Yetter ISOBUS Y Harness at the Yetter Control Box. Install the triangular 3 pin connector on the 2940-655 to the triangular 3 pin connector on the 2940-654 Yetter Control Harness.
- Step 2:** Remove the JD rear terminating resistor harness from the seeder. Install the 2940-659 JD ISOBUS Adapter Harness.
- Step 3:** Install the 2940-657 (15ft) or 2940-658 (30ft) extension harnesses between the 2940-655 & 2940-659.

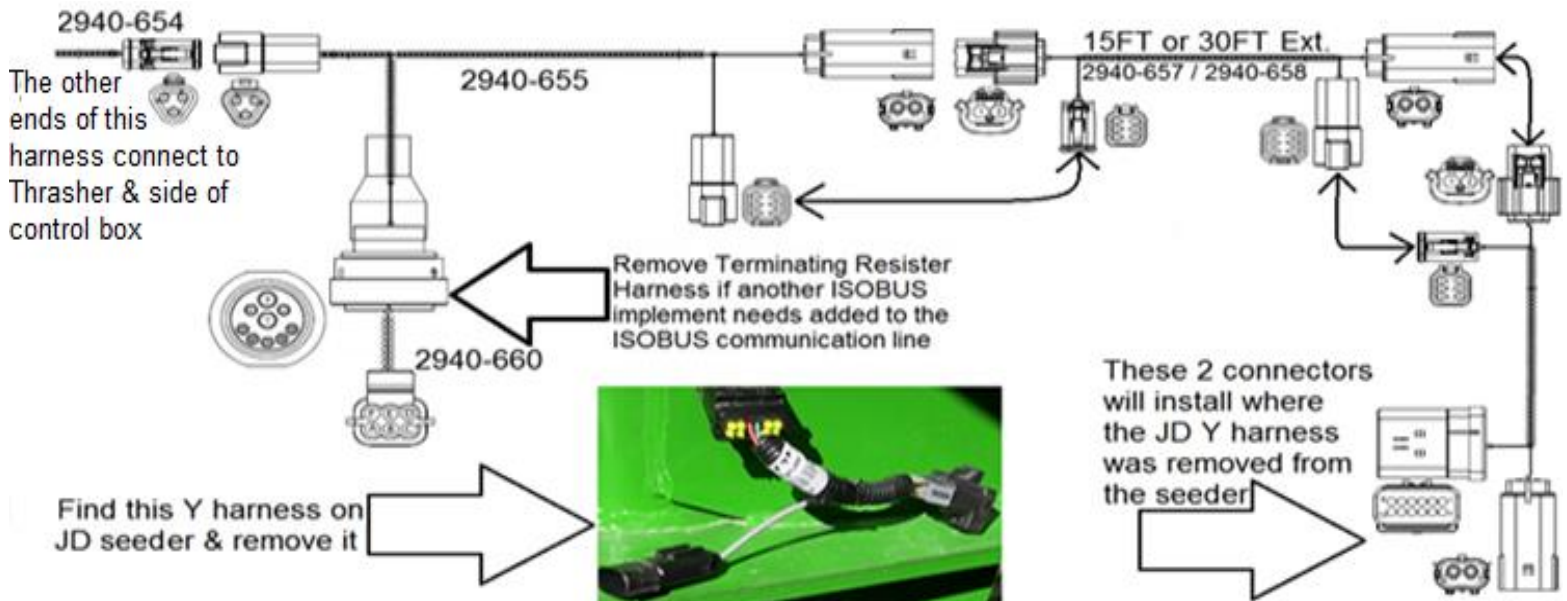

Yetter Compressor Installation

Step 1: Preparation

ELECTRIC COMPRESSOR: The crate labeled 2940-050A includes 1) Yetter electric compressor, 1) 2940-181 Y harness, 1) 2940-189 10FT Compressor Control Harness, 1) 2940-150 80A Breaker Cable, 1) 2940-151 Main Power Extension, & 2) 2940-163 20FT Main Power Extensions. Open filter assembly, inspect condition of filter, reinstall. (SEE **PAGE 12** FOR FILTER LOCATION)

HYDRAULIC COMPRESSOR: The crate labeled 2940-055 includes the Yetter hydraulic compressor, 1 liter bottle of oil, 2940-181 Y harness, & 2940-189 10FT compressor control harness. Remove compressor from crate. Remove the housing by removing 6 bolts (4 are pictured in picture 1 below, the other 2 are on the opposite side of the housing) using a ratchet with 7/16 socket & 7/16 wrench. Remove the dipstick & slowly fill pump with provided oil until oil reaches fill line on the sight glass. Fill the pump slowly as there is a delay between oil entering pump & seeing oil on the sight glass. Confirm oil level is full on the dipstick as well. Reinstall dipstick, housing, & control block. Remove wing nut on the air filter housing, remove air filter cover, & inspect condition of the air filter. Reinstall filter, cover, & wing nut making sure filter is sealed between filter base plate & cover.

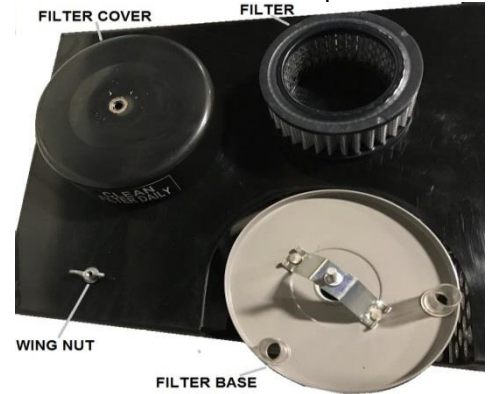
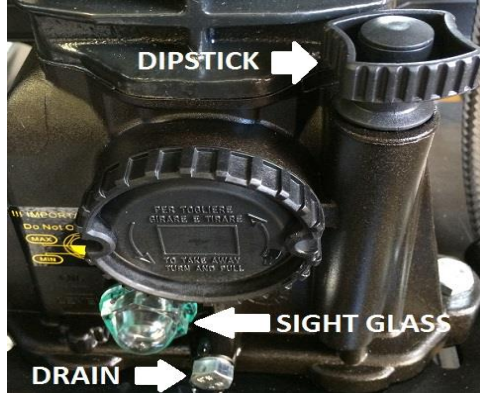
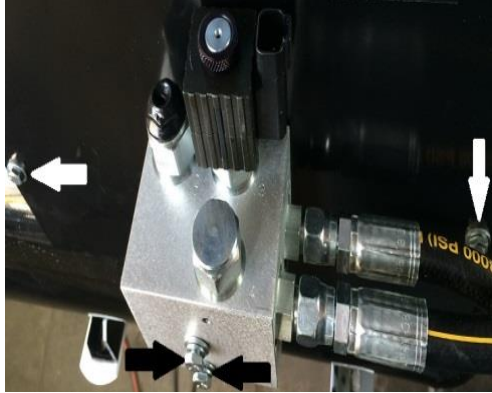

Step 2: Mounting

Every seeder/tractor combination will contain its own unique situations in regard to mounting the 2940 Compressor Assembly for clearance/accessibility. **YOU SHOULD EXERCISE YOUR OWN BEST JUDGEMENT TO FIT YOUR SITUATION.** Begin by locating a suitable mounting location. Placement will vary on make & model of seeder. Use mounts supplied or **depending on application different mounts may need to be built. See examples below labeled customer built bracket.** Be sure to check clearance in all locations, especially noting tractor tires, folding/unfolding the planter for transport mode, marker arms, fertilizer tanks, & 2-point top link. Yetter has 4 different mounting kits; 2940-085 to mount compressor to top link of the 2 point hitch, 2940-086 to mount to seeder tongue cross member, 2940-090 to mount to an 8" X 12" bar, & 2940-091 to mount to an 8" X 16" bar. **See page 48** in the Part Identification for proper assembly of the mounting kit & compressor mounting. A process of folding & unfolding, turning in a tight circle, & raising/lowering markers & planter is recommended to ensure compressor clearance.

2940-085 – 2 Point Mount



2940-086



2940-090



2940-091



CUSTOMER BUILT BRACKETS (Call Yetter Service Department for additional photos)



Yetter Electric Compressor Installation

Step 3: On electric compressor installation, install the 2940-150 on the tractor battery. Red cable connects to positive battery post & black cable connects to negative battery post. Install the 2940-151 (10ft) & 2940-163 (20ft) main power extensions until you reach the compressor. Install the connector on extension to the large connector on electric compressor unit.



Hydraulic Compressor Installation – Hose/Fitting Kits

- All fittings & adaptors do not have to be used
- Additional fittings & adaptors may need purchased

2940-088 (PLANTER)	2940-089 kit (STAND ALONE)	Part #	Part Name	Description
Qty in kit	Qty in kit			
4	2	2515-324	ELBOW	90 DEG, 3/4 SAE TO -6 JIC
	2	2515-327	ADAPTER	3/4-16 SAE TO -6 JIC
3		2515-329	ADAPTER	REDUCER, -8 F TO -6 M JIC
2	2	2515-411	ELBOW	90 DEG 3/4 SAE TO -8JIC
3	1	2515-425	TEE	TEE 3/4 SAE
2		2515-428	ELBOW	JIC-6 90 DEGREE SWIVEL
3		2515-430	TEE	JIC-8 RUN TEE
2	2	2515-431	ADAPTER	9/16 SAE TO -6 JIC ADAPTER
1		2515-432	ELBOW	JIC-8 90 DEGREE SWIVEL
2	2	2515-831	HOSE	3/8 10FT HOSE -6 JIC F
1	1	2515-832	HOSE	1/2 10FT HOSE -8 JIC F
1	1	2515-833	ADAPTER	3/4 SAE TO -8 JIC
	2	2515-834	COUPLER	PIONEER, POPPET STYLE
1	1	2515-848	ELBOW	90 DEG, 1/4 SAE TO -6 JIC

2940-088 HYDRAULIC HOSE & FITTINGS KIT



2940-089 HYDRAULIC HOSE & FITTINGS KIT



Yetter Hydraulic Compressor Installation

Step 3: Hydraulic Hose and Fittings Installation to the Compressor

Tool required: An assortment of standard wrenches & crescent wrench.

- A) Remove the cap from the – 6 port (also labeled P on the Hydraulic Control Block) & install the 2515-431 – 6 ORB (O-Ring Boss) to – 6 JIC straight adaptor fitting so that the O-Ring end goes into the hydraulic block & the JIC end faces away from the block. Install 1) 2515-831 3/8 – 6 10ft hydraulic hose to that fitting.
- B) Remove the cap from the – 8 port (also labeled T on the Hydraulic Control Block) & install the 2515-833 – 8 ORB to – 8 JIC straight adaptor fitting so that the O-Ring end goes into the hydraulic block & the JIC end faces away from the block. Install the 2515-832 1/2 – 8 10ft hydraulic hose to that fitting.



- C) Remove cap plug from – 4 port on the motor (this is the Case Drain) using a 3/16 hex key wrench if equipped with threaded plug (may also have rubber plug) & install the 2515- 848 –4 ORB to – 6 JIC 90 degree adaptor fitting so that the O-Ring end goes into the hydraulic motor & the JIC end faces downward. Install 1) 2515-831 3/8 – 6 10ft hydraulic hose to that fitting.



Control Box to Yetter Compressor Wiring Installation

Step 1: Install the 2940-181 Solenoid/Pressure Switch Control Harness on the compressor.

Step 2: Install the 2940-189 harness between 2940-181 harness & 4 pin connector on the side of 2940-103A control box.

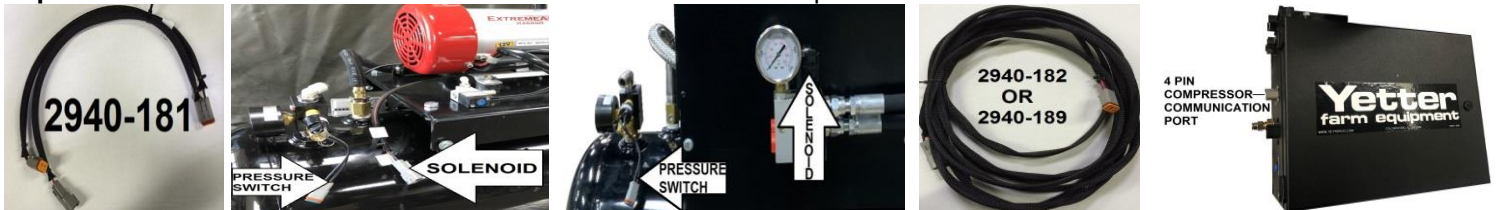

2940-114 Stand Alone Compressor Wiring Kit Installation

NOTE: This kit is only used when the 2940-103A Control Box is not being used!!!

Step 1: Install the 2940-518 Cab Switch harness in tractor cab. Mount the Switch in an area easily accessible. The 2 bare wires need spliced to the OEM Switched Power Connector (not supplied), & the female 2 pin Deutsch routes to tractor hitch.

Step 2: From 2 pin female Deutsch on 2940-518 at hitch, install 1-3 2940-154 (30ft ext.) harnesses as need to reach compressor.

Step 3: Install the 2940-525 at compressor as labeled in photo below. Install the 2940-154 into the remaining open connector.



Yetter Hydraulic Compressor Installation

Step 4: Hydraulic Connection

There are 2 ways to supply hydraulic flow to the compressor: an open SCV on the tractor (**which is recommended for this application**) or plumbing into a seeder circuit. If plumbing into a seeder's circuit, the circuit must have constant hydraulic flow when the seeder is in use. Always plumb between the tractor's SCV & the hydraulic block on the seeder. Plumbing downstream of the hydraulic block may cause inconsistent flow to all functions driven by that hydraulic circuit. **PTO driven & power beyond hydraulic circuits are NOT to be used when plumbing the Yetter hydraulic compressor.** When running, the Yetter hydraulic compressor requires a maximum of 4 gallons per minute. The 2940-088 hydraulic fittings kit is used to tie into a seeder circuit & 2940-089 hydraulic fittings kit is for using an open SCV remote on the tractor. In some applications, more fittings & longer hydraulic hoses may need purchased to make the hydraulic connection. It is recommended to use 1 hydraulic hose from the compressor to the location where the connection is made, splicing hoses together cause more potential leak points. Additional hydraulic plumbing pictures may be acquired by calling Yetter service, 800-447-5777.

BULKHEAD ON DB PLANTERS



SCV DIRECT

HYDRAULIC BLOCK AT THE REAR OF THE PLANTER

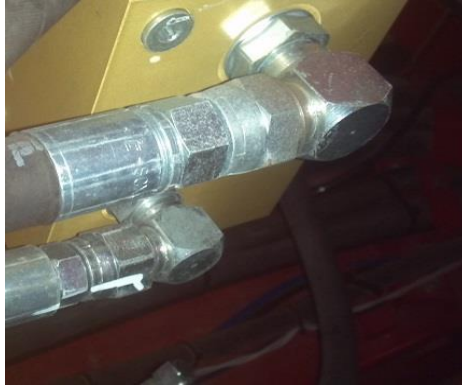

TEERING BEHIND PIONEER COUPLER

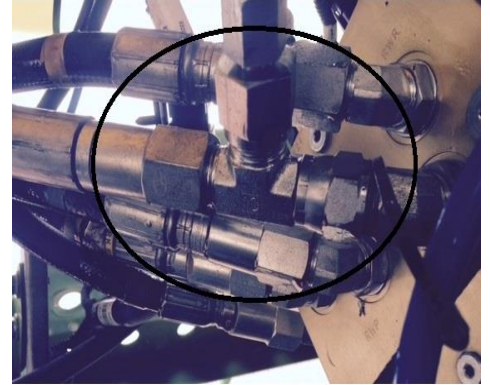

KINZE 4900

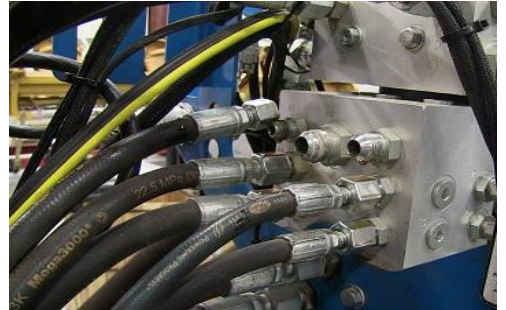
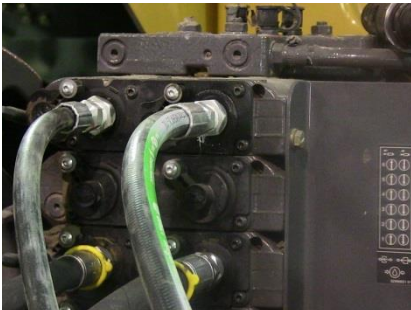

Step 6: Connect the hydraulic hose attached to case drain on the motor to case drain connector on the tractor or by teeing into a case drain circuit on the seeder. Below are a few examples of hydraulic connection. The Yetter hydraulic compressor is equipped with a case drain port on the motor. Case Drain is a pressure free circuit that provides a flow path to the reservoir for hydraulic fluid used to cool & lubricate the motor. Make sure to connect the case drain to the reservoir where the hydraulic flow to the compressor is received. If tractor isn't equipped with case drain, a kit may be purchased from the OEM tractor dealer.

CASE DRAIN FLAT FACE COUPLERS CONNECTED AT TRACTOR



TEE INTO EXISTING CASE DRAIN

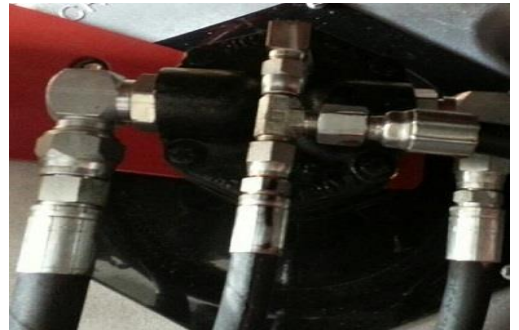

NOTICE: THESE ARE EXAMPLES ONLY. USE YOUR BEST JUDGEMENT TO FIT YOUR SITUATION



Airline Routing –Compressor to Control Box

Yetter Compressor

- Step 1:** Install 2940-367 250psi rated 3/8 airline from compressor outlet to inlet (water trap side labeled A) of water separator.
- Step 2:** Install 2940-345 3/8" black airline from outlet port of water separator (labeled B) to inlet port (labeled 1) on control box.
- Step 3:** Route 1/4" airline from 1/4"PTC elbow (labeled C) on water separator to 1/4"PTC fitting (labeled 2) on bottom of control box.
- Step 4:** Route 1/4" airline from the 1/4"PTC fitting (labeled 3) on side of control box toward the ground making sure the end of the airline is not pointed toward anything that moisture may damage or rust.

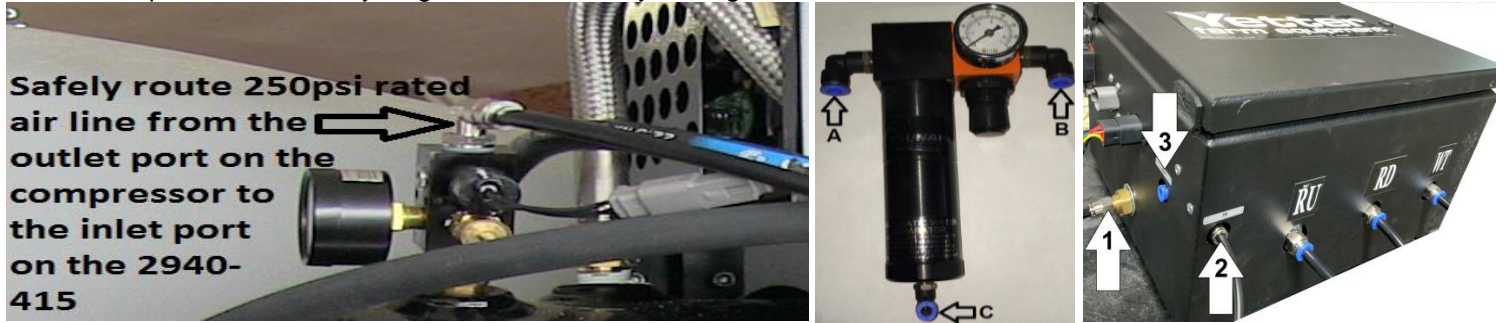

Yetter Compressor Communication Harness

- Step 1:** Install 2940-181 compressor solenoid/switch harness; male 2 pin connector installs into female connector on On/Off solenoid, female 2 pin connector installs into male 2 pin connector on pressure switch.
- Step 2:** Connect the 2940-189 (10ft) control harness to 4 pin connector of the 2940-181 & route to control box. If more length is needed, call Yetter & order more. (2940-182 is 20ft length; 2940-189 is 10ft length)
- Step 3:** Connect the 2940-182 or 2940-189 into the 4 pin female connector on side of the control box.



John Deere Hydraulic Compressor

- Step 1:** Locate the manifold block on the hyd. comp., drain air pressure from tank/manifold block, & remove gauge/pipe plug.
- Step 2:** If pipe plug equipped, install 2940-408 3/8 PTC elbow where plug was removed. If gauge equipped, install 2940-374 adaptor. Male end gets Teflon tape & installs on manifold block, gauge installs in rearward facing female end, & 2940-408 3/8PTC elbow installs in remaining end.
- Step 3:** Install 2940-367-250psi rated 3/8 airline from the 3/8 PTC elbow fitting to the inlet port (labeled A) of water separator.
- Step 4:** Route 2940-345 black 3/8"airline from outlet port (labeled B) of water separator to inlet port (labeled 1) on control box.
- Step 5:** Route 1/4" airline from 1/4"PTC elbow (labeled C) on water separator to 1/4"PTC fitting (labeled 2) on bottom of control box.
- Step 6:** Route 1/4" airline from the 1/4"PTC fitting (labeled 3) on side of control box toward the ground making sure the end of the airline is not pointed toward anything that moisture may damage or rust.



PIPE PLUG ONLY

GAUGE INSTALLED

2966-050 Lift Kit Installation

2940-136 Dump Valve Assembly

Step 1 – Align the holes on valve (8) with mounting plate (3) holes. Insert bolts (5) through the aligned holes and start the nuts (4) on the threads. Tighten nut with 1/4" wrench while holding bolt with a Phillips screwdriver until tight.

Step 2 – Install supplied 6" piece of airline (6) in port 1, the vent elbow (7).

Step 3 – If install is on a John Deere planter, use flat flanged nut (1) to install Dump Valve assembly by placing circle cut out on mounting tab (3) on U-bolt used to mount the row unit to planter toolbar. Pinch mounting tab (3) between existing nut on U-bolt & the flat flanged nut (1). If install is on any other OEM planter, use the serrated flanged nut (2) for the install of the dump valves. In some applications, dump valve mounting may require additional hardware and/or brackets to be made.

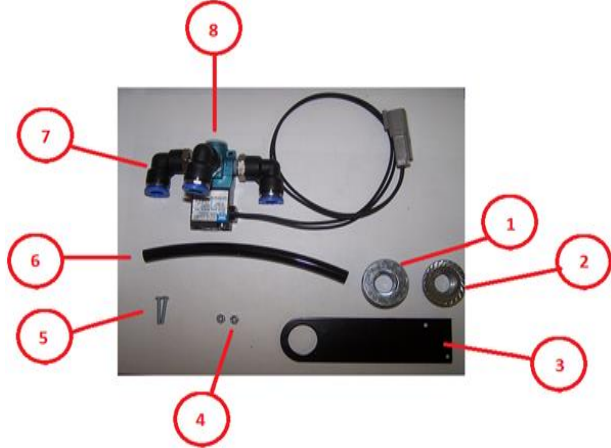

Solenoid Down



Solenoid Up

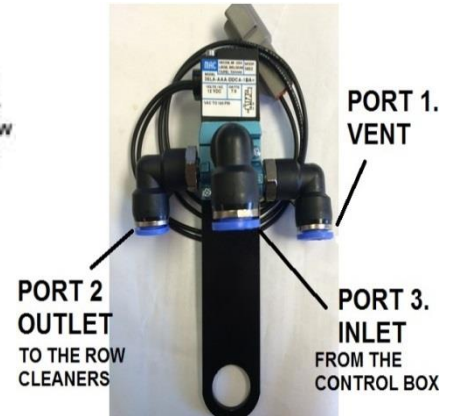

Single Dump Valve Mounting

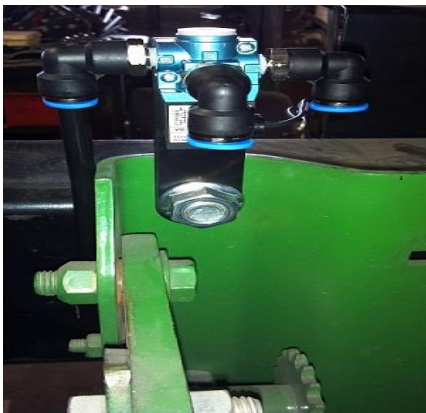

Dual Dump Valve Mounting



Dump Valve, Lift Switch, & Harness Installation

Step 1: Mount 3 or 4 dump valves per section on the seeder: Left Wing, Center Section, & Right Wing. It is best to spread them out on each section, especially on seeders with 32 rows & more. Use the mounting tab that comes with the dump valve kit to mount the dump valves to the seeder. In some cases, modifying the mount tab or fabricating a new mount for the dump valve may be needed.

Step 2: Mount the 2940-197 lift switch so that the spring mechanism gets tripped right away as the seeding units are raised. This will ensure the pneumatic residue managers raise quickly before the seeder begins to turn. Mount bracket for the limit switch will need fabricated.

Step 3: Install a 2940-158 Y harness in the 2940-153A at the tractor hitch. Install the 2 pin on the 2940-164A/165A into 1 of the male connectors on the 2940-158. In the other 2 pin connector on the 2940-158, install 1) 2940-154 OR 2940-156 from the hitch to the connector on the lift switch.

Step 4: From remaining open connector on lift switch, use 5ft/15ft/30ft extensions, & Y harnesses to connect all dump valves to limit switch.

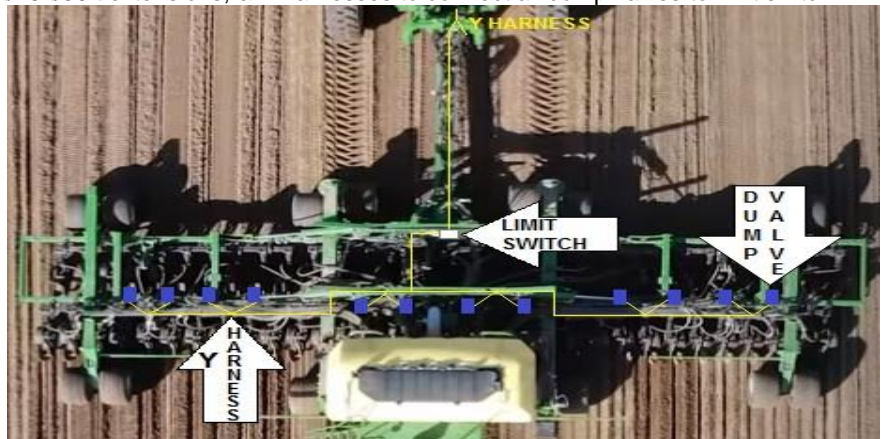

Airline Routing – Seeder Frame

Below is a suggested method for safely & securely routing the airlines on the seeder frame whether installing trunk airlines (airlines routing to the row cleaner air cylinder) or supply airlines (airlines that route from the control box to the trunk airlines). Safely route the airlines on the frame that the row units are mounted to or follow the path to which the hydraulic hoses on the seeder are routed. After airline installation is complete & system is tested, use provided zip ties to keep parts away from pinch & wear points.



Airline Routing – Row Unit

Above is a suggested method for safely and securely routing the airlines from the air cylinder to the tees on the seeder frame. These are generalizations & **YOU SHOULD USE YOUR OWN BEST JUDGEMENT** in routing airlines. DO NOT pass the airlines between the front of the rock shaft & seeder frame. This can act as both a pinch points & wear points. If necessary, use provided zip ties to keep airlines away from pinch & wear points & sharp or rotating objects that may damage the airline.

Specific airline routing will be dependent upon: Row unit spacing (15", 20", 22", 30", 36", etc), number of ranks (single or dual), & other variables. RM units will have 1 up pressure fitting & 1 down pressure air fitting per cylinder.

The following page has airline diagrams to reference. The wiring/tubing kit will have everything needed to complete installation.

ALL DOWN PRESSURE SUPPLY AIRLINES WILL PLUMB INTO THE DUMP VALVES INLET PORT (PORT 3)
ALL DOWN PRESSURE TRUNK AIRLINES WILL PLUMB INTO THE DUMP VALVES OUTLET PORT (PORT 2)
NO UP PRESSURE AIRLINE SHOULD HAVE A DUMP VALVE INSTALLED ANYWHERE IN THE CIRCUIT

Direction of flow: Supply Tank → Water Separator Assembly → Control Box → Air Bags All airlines will be 3/8". Blue airline is used on lift pressure side of air cylinder & black airline is used on down pressure side of air cylinder. Use airline colors to differentiate lift pressure (Blue Airline) & down pressure (Black Airline) on seeder for troubleshooting & leak detection indication. Route airlines as efficiently & conveniently as possible.

Step 1: Left Wing Trunk Airline – Route Blue & Black airline from the 1st row on the left wing to the last row on the left wing. Follow these airlines back to the 1st row installing a tee at each row. When back to row 1, cut the blue & black airline to length & install in the air cylinder fitting, blue airline to rod end of cylinder & black airline to top end of cylinder. At each row on the left wing with tees installed, install blue airline from tee in blue airline to up pressure fitting on cylinder & black airline from tee in black airline to down pressure fitting on cylinder. If seeder has 2 ranks, repeat this step on the left wing back rank. Install tees & blue airline to connect the front rank up pressure to the back rank up pressure in 2 or 3 different locations on the left wing. Install tees & black airline to connect the front rank down pressure to the back rank down pressure in 2 or 3 different locations on the left wing.

Step 2: Right Wing Trunk Airline – Route Blue & Black airline from the 1st row on the right wing to the last row on the right wing. Follow these airlines back to the 1st row installing a tee at each row. When back to 1st row, cut the blue & black airline to length & install in the air cylinder fitting, blue airline to rod end of cylinder & black airline to top end of cylinder. At each row on the right wing with tees installed, install blue airline from tee in blue airline to up pressure fitting on cylinder & black airline from tee in black airline to down pressure fitting on cylinder. If seeder has 2 ranks, repeat this step on the right wing back rank. Install tees & blue airline to connect front rank up pressure to back rank up pressure in 2 or 3 different locations on right wing. Install tees & black airline to connect front rank down pressure to back rank down pressure in 2 or 3 different locations on right wing.

Step 3: Center Section Trunk Airline – Route Blue & Black airline from 1st row on center section to last row on center section. Follow these airlines back to 1st row installing a tee at each row. When back to 1st row, cut blue & black airline to length & install in air cylinder fitting, blue airline to rod end of cylinder & black airline to top end of cylinder. At each row on center section with tees installed, install blue airline from tee in blue airline to up pressure fitting on cylinder & black airline from tee in black airline to down pressure fitting of cylinder. If seeder has 2 ranks, repeat this step on center section back rank. Install tees & blue airline to connect front rank up pressure to back rank up pressure in 2 or 3 different locations on center section. Install tees & black airline to connect front rank down pressure to back rank down pressure in 2 or 3 different locations center section.

Step 4: Up Pressure (RU) Supply Airline – Install blue airline from the RU port on the 2940-103A control box to the center of the seeder & install a tee. From each side of the tee, install blue airline to the center of each wing & install a tee in the wing up pressure trunk line to connect the RU supply line. Install a tee in the center section trunk line, install a tee in the RU supply line, & install blue airline between the 2 tees to supply up pressure to center section. On larger seeders with a lot of rows, teeing the supply line into the trunk lines on each section a few times is needed.

Step 5: Wing Down Pressure (RD) Supply Airline – Install black airline from RD port on 2940-103A control box to center of seeder & install tee. From each side of tee, install black airline into inlet port (port 3) on each dump valve on left & right wings. From the outlet port (port 2) on left wing dump valves, install airline into trunk airline, using tees. From outlet port on right wing dump valves, install airline into trunk airline using tees.

Step 6: Center Section Down Pressure (WT) Supply Airline – Install black airline from WT port on 2940-103A control box to inlet port (port 3) on all dump valves on center section. From outlet port (port 2) of each center section dump valve, install airline into trunk airline using tees.

Airline Plumbing Diagram

The following airline diagrams give you a generalized schematic of how airline should be plumbed on all seeders. Blue lines represent up pressure (blue) airline, red lines (used for clarity) represent down pressure (black airline).

Up Pressure Schematic

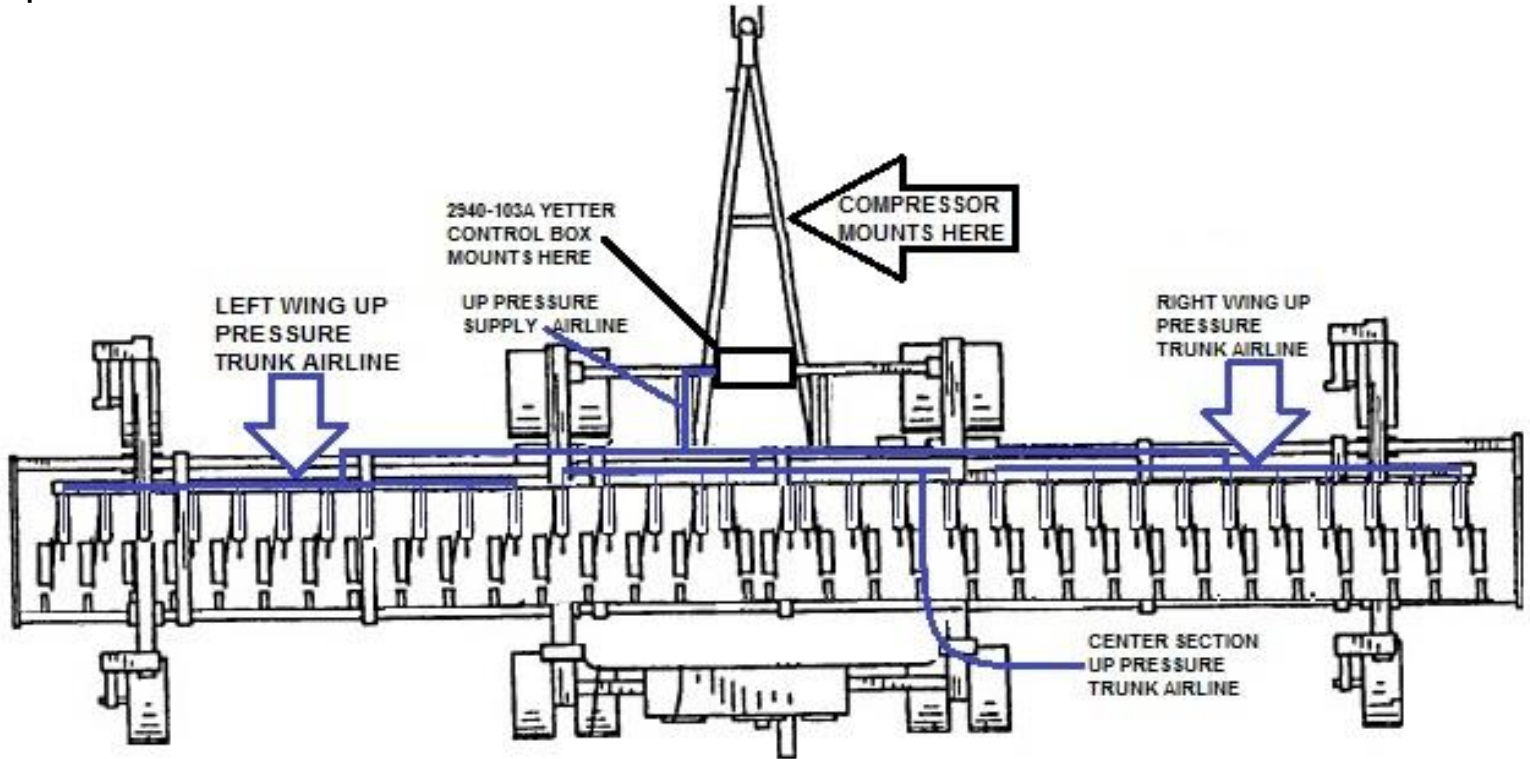

Down Pressure Schematic

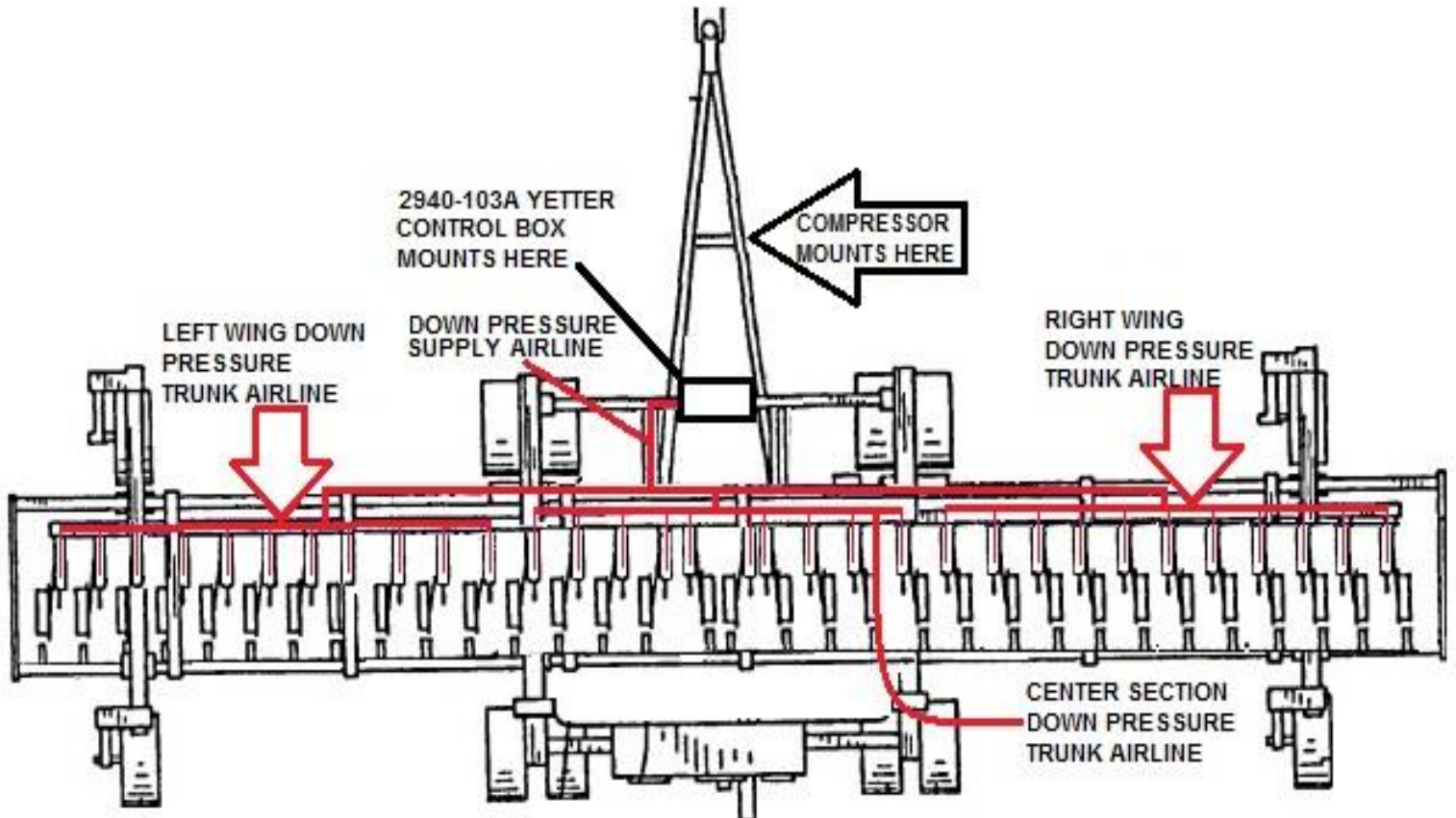

DUMP VALVES ARE NOT SHOWN IN THESE AIRLINE DIAGRAMS

Airline Plumbing Diagram

**DUAL RANK SEEDER
UP PRESSURE AIRLINE
PLUMBING**

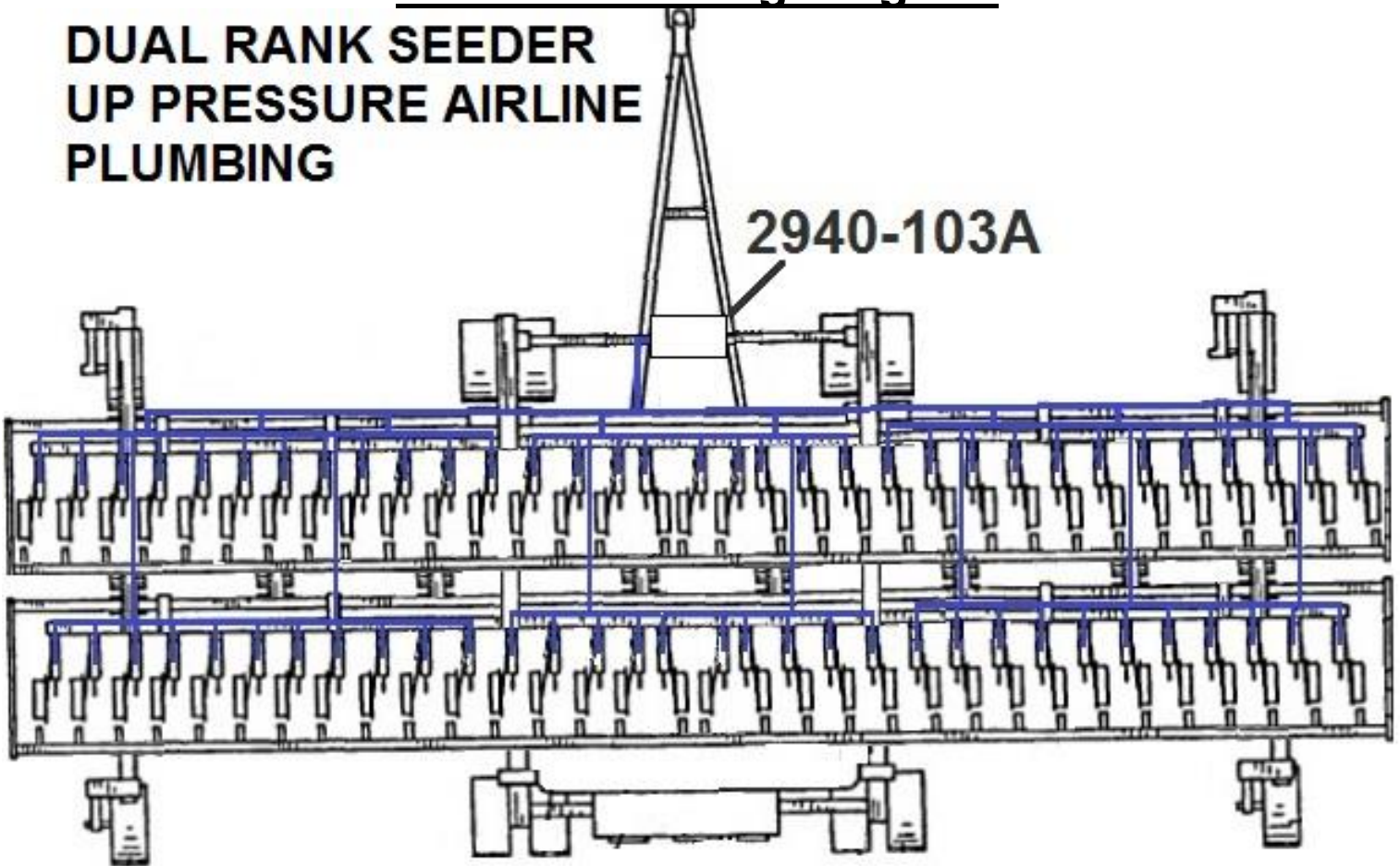

**DUAL RANK AIR SEEDER
DOWN PRESSURE
AIRLINE PLUMBING**

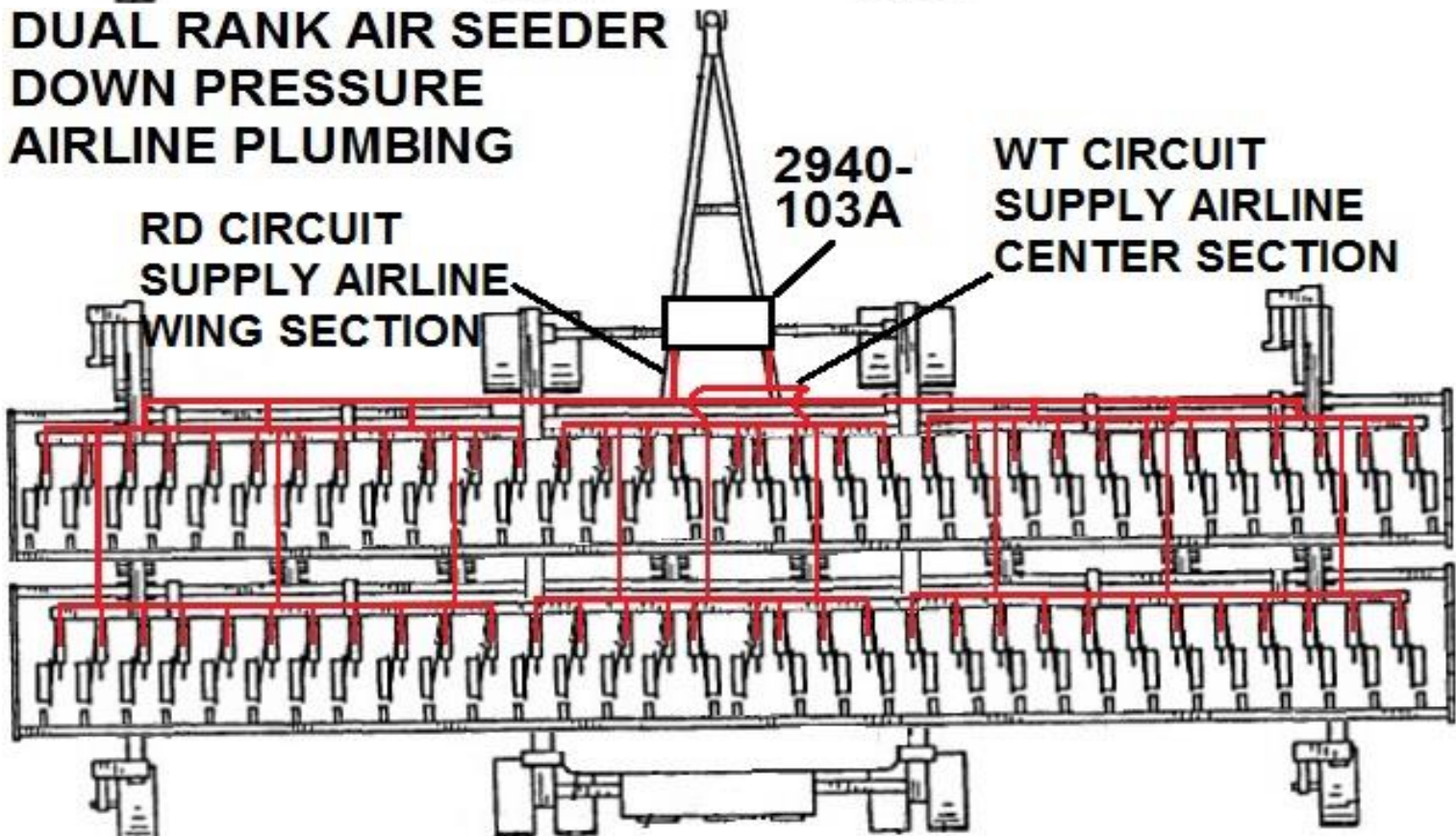

DUMP VALVES ARE NOT SHOWN IN THESE AIRLINE DIAGRAMS

Downloading the Yetter App (Tablet Operation Only)

- STEP 1:** Go to your tablets app store, search Yetter Air Adjust & download the Yetter app.
- STEP 2:** When connecting to the Air Adjust WiFi signal for the first time, a password is required.
PASSWORD IS: 12345678
- STEP 3:** Put the Yetter icon on your tablet in a spot that is easy to get to.
- *ANYTIME POWER IS RESTORED TO THE 2940-653 THRASHER MODULE, GO INTO SETTINGS TO CONNECT BACK TO "AIR ADJUST" WIFI TO CONNECT TO THE YETTER SYSTEM.***



SMART PHONES ARE NOT COMPATIBLE WITH THE YETTER SYSTEM AT THIS TIME

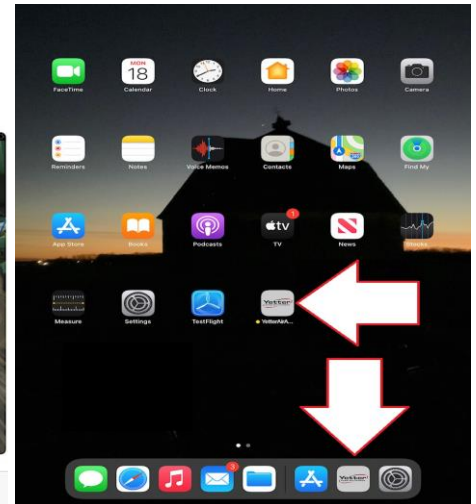
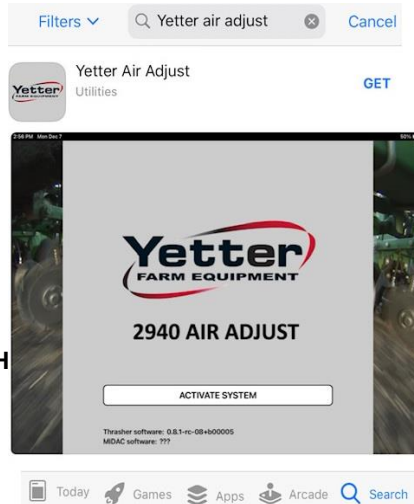

Cab Controller Operation – Tablet & ISOBUS

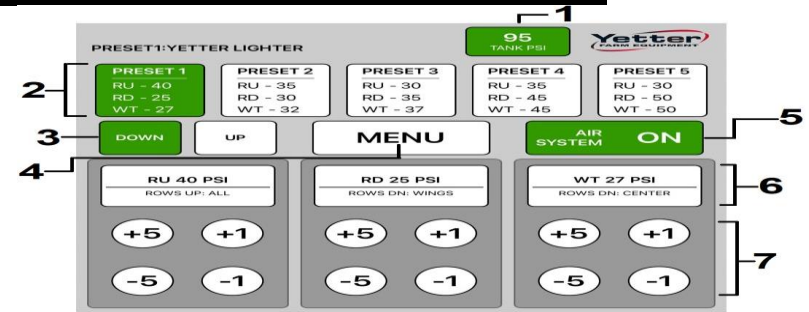

ACTIVATION SCREEN – Press the **ACTIVATE SYSTEM** icon to engage the system & get to the operation screen.

- SYSTEM PRESSURE/COMPRESSOR MONITORING** Just to the left of the Yetter logo, you can monitor system pressure. If the system is below 75psi upon initial startup or below 50psi for more than 5 seconds during operation, the rectangle will turn red & system will not allow air to the row cleaner air bags. If the rectangle is green, the system pressure is good & operator is in full control of the system. The tank psi reading is taken down-stream of the water separator/regulator assembly & won't represent actual tank pressure. Actual tank pressure should be 125-145psi.
- PRESETS 1 – 5:** 5 Presets allow for quick changes on the go for changing field conditions or can be used as starting points for starting a new field. Presets can be edited in the Menu section where you can change the name of the preset or the psi that the preset is currently saved as. The preset that is being used will be highlighted in **GREEN** & the name of the preset will be shown. If the operator has made a manual adjustment from the saved Preset, an asterisk (*) will display in front of the name of the preset.
- DOWN** – Press this icon to apply the commanded target pressures.
UP – Pressing the **UP** icon will raise the rows by draining the down pressure & applying 40psi of up pressure.
- MENU**- Press to display Menu Options. If in Menu Options, pressing **BACK** will take the operator back one screen & pressing **EXIT** will take you back to the main operating page shown above. See [page 32](#) for MENU screen navigation.
- AIR SYSTEM ON** – Displays the state of system. Press this icon to deactivate system.
(THIS SHOULD BE PRESSED BEFORE SHUTTING TRACTOR OFF)
- RU, RD, & WT** – These give you the target pressures for each circuit. The name of each circuit can be renamed. For example, if on a split row planter, you plumb the back rank down pressure separate from the front rank down pressure, you can rename the **RD** circuit **FRONT ROWS DOWN** & the **WT** circuit **BACK ROWS DOWN**. Touch the name to edit.
- MANUAL PRESSURE CHANGE:** Each circuit can be edited individually by +/-1psi or +/-5psi increments.

AIR SYSTEM FILLING – If the compressor supplying air to the Yetter 2940 system has less than 75psi, the Yetter 2940 system will not supply air to the air bags of the row cleaners. If the system is above 75psi & then drops below 75psi for 5 seconds, the Yetter 2940 system will return to the **AIR SYSTEM FILLING** state. A leak check needs performed.

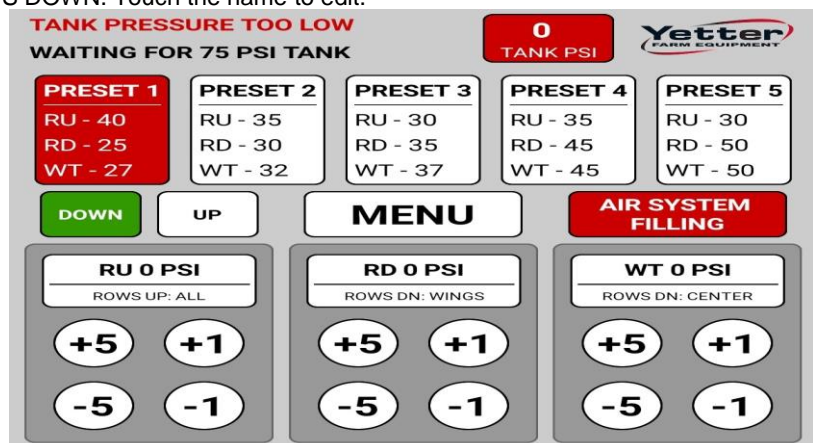

2940 Air Adjust Operation

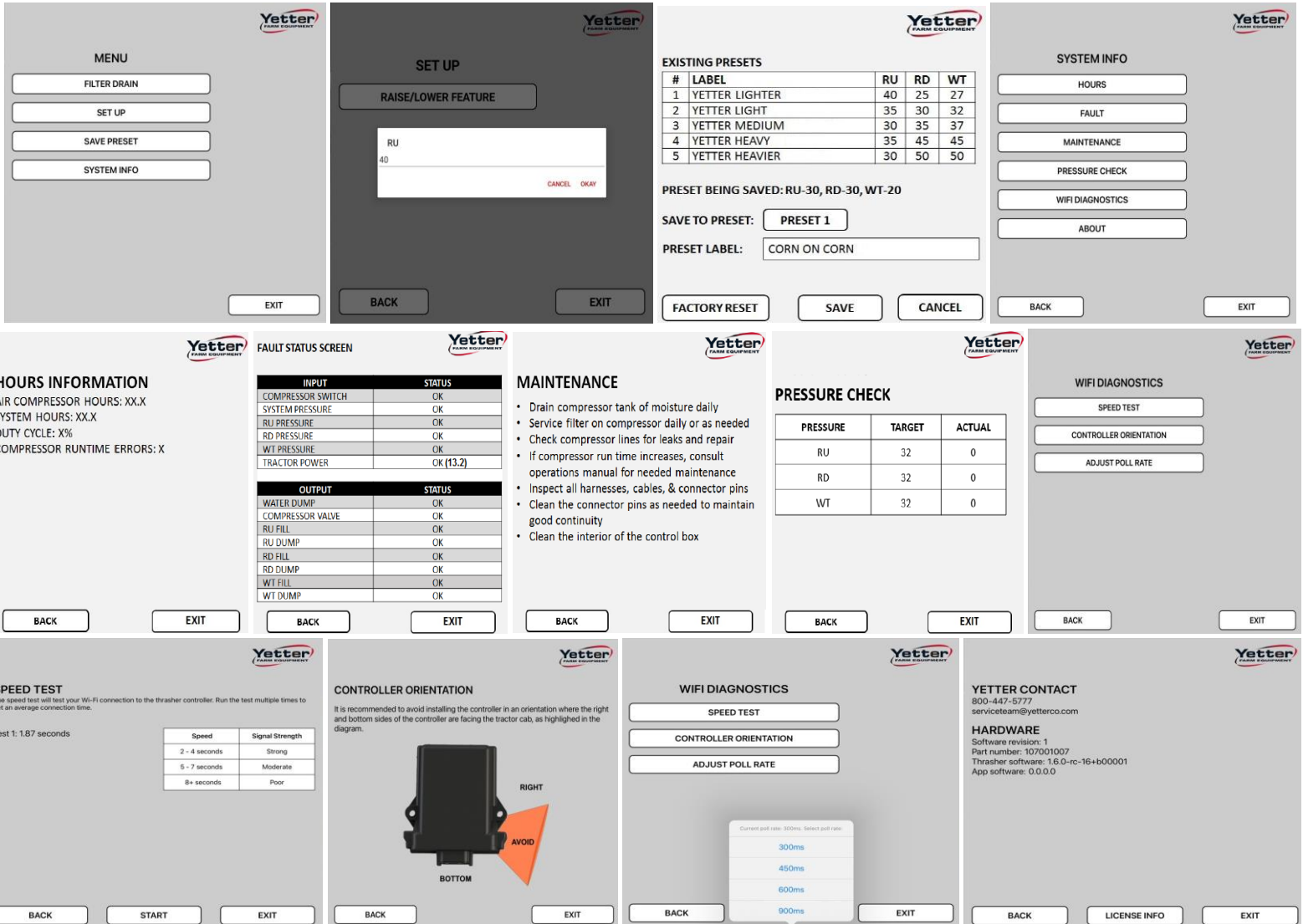

Screen Control and Navigation:

MENU: Press this icon to take you away from operation screen. **EXIT** will take you to operation screen. **BACK** will take you to the previous screen.

FILTER DRAIN: Pressing this icon will drain the water separator valve for 5 seconds. The water separate valve will cycle for 7 seconds every time the system in powered on. The system is also programmed to open the water separator drain valve for 5 seconds every hour.

SETUP: Pressing this icon will take you to a screen where you can edit the amount of up pressure to raise the row cleaner. From the factory, this is preset at 40psi. Touch 40 to edit & press OK to save.

The minimum you can set this is 25psi, the maximum is 100psi. If you have air bags, DO NOT set above 60psi.

SAVE PRESET: The system will have 5 factory presets stored & named. Preset 1 being the lightest & 5 being the heavier/more aggressive. If the operator adjusts pressures away from a preset & wants to save these new target pressures as a preset, press MENU, then SAVE PRESET, select which preset you want to save these new target pressures on (1 – 5), rename preset if desired, & press SAVE. Pressing FACTORY RESET will change all presets back to factory settings.

SYSTEM INFO: On the system info screen, the operator can select from 6 different icons

HOURS: Air compressor hours is the amount of time compressor has ran (or was supposed to be running), System Hours is the amount of time air adjust system has been activated, Duty Cycle is the percentage of time compressor has been engaged in accordance with system hours, (i.e. if compressor hours 5 & system hours is 50, duty cycle is 10%), & Compressor Runtime Errors is the amount of times compressor has ran for 15 continuous minutes.

FAULT STATUS: displays the status of the system. Anytime a CHECK FAULT STATUS message pops up in the top left corner of the operation screen, navigate to this page to determine what may be the problem.

MAINTENANCE: will display some details that should be regularly practiced to prolong the life of the Air Adjust system.

PRESSURE CHECK: allows the operator to make sure his target pressures & the actual pressures are in tolerance. The tolerance specs are +/- 7psi of the target pressure. If target is 30, actual is 35, that is within tolerance.

WiFi Diagnostics: allows to check signal strength by running a speed test, which side of the module should face the cab, & change messaging speed.

Speed Test: Press start to run a test, the lower the time, the better the signal strength. Use the chart as a guide to check your WiFi signal

Controller Orientation: If having communication issues, use this guide to make sure strongest signal producing side of module is facing tractor cab

Adjust Poll Rate: If having communication issues, adjust the poll rate to 450, 600, or 900ms to slow the messages being sent back & forth

ABOUT: This is info about the system & contact info for Yetter if any questions or service issues come up.

2940 Air Adjust Operation

Error Messages



NO BATTERY POWER: If the 40A Breaker trips or a battery power cable becomes disconnected or damaged & insufficient power is delivered to the Yetter 2940-103A, this message will appear. Inspect the breaker/power cables & repair.

NO CONNECTION TO THRASHER: If the 2940-653 Thrasher module is not connected to ISOBUS or Tablet controller, this message will appear. Check lights on the Thrasher module (mounted to exterior of the control box), if using a Tablet, the operating status & status 1 lights will illuminate. Make sure the tablet is connected to the WiFi signal named AIR ADJUST. If using ISOBUS, the status 2 light will also illuminate. In some situations, the operator will have to unplug the 2 pin connector from the tractor power strip, plug it back in, reconnect to the Air Adjust WiFi, & re-open the Yetter App. Adjusting the Poll Rate to a higher millisecond messaging speed, such as 450, 600, or 900, will help as well.

HIGH COMPRESSOR RUN TIME: If using a Yetter compressor, the system has a time limit that the compressor can run before timing out. If the compressor runs for 15 minutes without turning off via the pressure switch, this message will appear. Perform a leak check on the system. On hydraulic compressors, this message will appear while in transport when no hydraulic flow is being sent to the hydraulic motor on the compressor.

NO CONNECTION BETWEEN THRASHER & MIDAC: If there is no communication between the 2940-112A Midac control module inside the 2940-103A control box & 2940-653 Thrasher module on the outside of the control box, this message will appear. Check the connections/harness between the 2 modules to make sure nothing became disconnected/damaged.

Operation Settings:

“How much Down/Lift Pressure should I be running?”

The amount of Down/Lift Pressure will vary greatly across soil types, tillage practices, soil moisture, row unit weight & many other variables. Manage the pressure in the down &/or lift circuits in order to maintain 90%+ ground contact while keeping the pressure between 10-60 psi. The cab controller will display the tank pressure in psi, if the compressor is engaged, a lightning bolt will appear, & the down/lift circuits in psi. A typical starting range for residue managers (RM) would be 35psi up, 30psi down, and 32psi WT. A typical starting range for RM/ combo would be 30psi up, 35 psi down, 37psi WT. When an ideal pressure setting is found for a certain field condition & the operator wants to save it as a preset, press MENU, press SAVE PRESET, select the preset you want to save over, rename the preset if desired, & press SAVE. If the residue managers aren't removing enough residue, add more down pressure or subtract some up pressure. If the residue managers are being too aggressive, subtract down pressure or add up pressure.

Normal operating ranges:

- Down Pressure Bags: 10-60psi
- Lift Pressure Bags: 10-60psi
- Tank Pressure: The gauge at the tank will read 145psi when full. The tank pressure reading on the cab controller will be around 100-120psi, depending with the regulator on the water separator assembly is set at. The tank has a safety relief valve that will automatically exhaust excess pressure in the event that the pressure would exceed 175 psi.
- A minimum of 30psi should be maintained in the up pressure circuit to allow the row cleaners to lift via the limit switch kit.

2940 Operation Guide

System Start Up Procedure

Below is the 2940 system startup procedure that should be followed every time the 2940 system is turned on. This will ensure that component parts of the system are working correctly. If this is the first start up procedure after installation, make sure to familiarize yourself with cab controller operation first.

Step 1: Supply switched power to control box (start the tractor or turn the key forward if just testing the system with shop air)

Step 2: If using Tablet, connect to Air Adjust WiFi (**password is 12345678**) & open Yetter App. Press ACTIVATE SYSTEM. If using ISOBUS, open Yetter run page & press ACTIVATE SYSTEM.

Step 3: If using Yetter compressor, the compressor should engage (apply hydraulic flow if applicable) to build 145psi & shut off. If 145psi isn't reached, **see page 36** to make an adjustment to the flow control valve. If Yetter compressor doesn't run & is below 125psi, check the 40A breaker (& 80A breaker on Yetter electric compressor applications) on tractor battery. Trip breaker & reset breaker arm firmly back into pocket. If using other OEM compressor, engage compressor & allow compressor to run a complete cycle & shut off. If using shop air, unplug onboard compressor's solenoid & make sure system pressure is at least 100psi.

Step 4: When compressor has shut off, press a preset (1 – 5) to apply air to the air bags of the residue managers. Make sure the TANK PSI holds steady. If tank pressure drops & will not hold, turn all pressures (RU, RD, & WT) to 0psi & perform leak check (**see page 37**). Once the tank pressure holds, proceed to the next step.

Step 5: Press the UP icon while watching all RMs. When this button is pressed, icon will turn green & RMs should all raise.

Step 6: Press the DOWN icon to lower RMs back to commanded target pressures.

ROW CLEANER DO'S AND DON'TS

1. **DO NOT** use as a tillage tool; RMs are designed to move crop residue & to break up clods & crust.
2. **DO NOT** operate seeder at slow speeds. Ground speed affects how aggressive the residue manager wheels are. Operate at sufficient speed (refer to you OEM seeder manufacturer manual) to maintain good residue flow.
3. **DO NOT** expect 100% of crop residue to be cleared, it is not necessary and would necessitate engaging the soil. The width of path cleared depends on ground conditions, depth setting, and ground speed.
4. **DO** expect to see wheels occasionally quit turning, indicating ideal (shallow) setting which is not moving soil.
5. **DO** adjust toolbar frame height 20"-22" and drawbar correctly. It is very important to ensure seeder opener will follow ground contours properly. **See Page 35 for the planter levelness and height.**
6. **DO NOT** run air pressure below 10psi or above 60psi. Full range of travel can be achieved between these settings.
7. **DO** grease the hub cavity of the bearings regularly (2021-older hub/bearings). Even though bearings are sealed, filling the hub keeps moisture, dirt, & debris from entering the hub and ruining the seal. **See page 41 for greasing intervals.**

IMPORTANT: For proper operation, the seeder frame must operate level (fore, aft and side to side) and at the correct height, typically 20"-22". Regularly inspect the residue managers for loose or worn bolts & hardware. Repair or replace as needed.



Overview:

This electronic control system works with a pneumatic system that controls pressure in the air bags on an agricultural application. The air bags provide independent up **AND** down pressure to the mechanical devices that are used on an agricultural implement.

System Layout:

There are (3) main parts to the control system. First, a VDM (Valve Drive Module) is to provide Outputs to control functions of the pneumatic system. The VDM will also provide Inputs to monitor the pneumatic system as well as provide feedback to the operator. The second part is an in-cab display (Tablet or ISOBUS VT) that allows the operator to control the pneumatic system and monitor its performance. Thirdly, the pneumatic system sends air to each circuit as commanded from the operator.

OPERATION

MACHINE OPERATION

Read this before field operation of the Yetter product.



NOTICE: Failure to properly set the planter frame height & levelness can result in less than successful operation of the planter & the Yetter product. This may result in **damaged equipment**. All operators should read & thoroughly understand the instructions given prior to using the Yetter product.

DO NOT use this product if the planter is not adjusted properly!

Make adjustments to seeder as necessary. Read seeder operator's manual for recommended setting. Check that toolbar are level fore & aft. Re-Check when seeder is in the field & has been fully loaded with seed, fertilizer, etc. Also, a field check with a bubble level on frame should be made of hitch height to ensure level operation front to back. It is important for seeder to operate level laterally. Tire pressure must be maintained at pressures specified by manufacturer. Field & actual planting conditions change & will dictate planter frame heights. Check seeder & row cleaner performance by digging & analyzing seed zone. For proper operation of planter attachments & row units, it is imperative that seeder toolbars & row units be level side-to-side & front-to-rear. Check manufacturer's operator's manual for instructions on how to adjust frame height & levelness.



From leading edge of disc opener blade,
row cleaner sticks forward 20"
from front of rock shaft bar,
row cleaner sticks forward 8"

|---19"---|

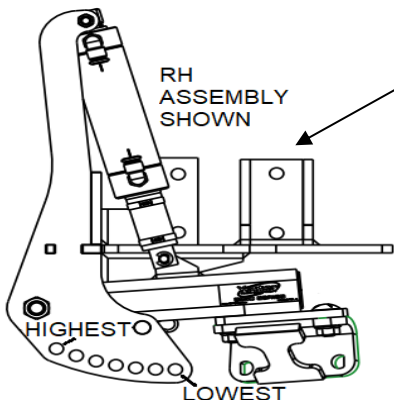

Adjust down stop pin to limit
down travel of row cleaner
(PIVOT ARM COMES PINNED UP)

Adjust angle of wheel to make
more or less aggressive

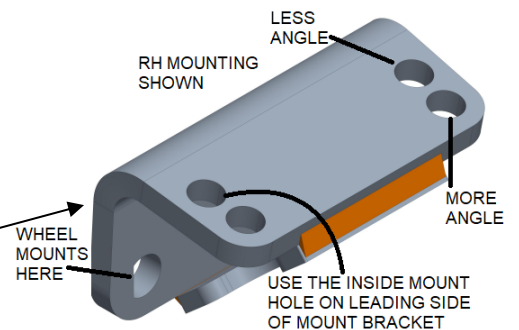

OPERATION PRECAUTIONS

To ensure the hydraulic compressor motor doesn't exceed recommended operating RPM level, the hydraulic oil flow control valve has been preset. In some instances, the compressor may run below optimum rpm, or will not reach 145psi of tank pressure read at the gauge on the compressor tank causing the VDM to think the compressor is running continuously. (High Compressor Run Time message will appear on cab controller) If this is the case, an adjustment to the flow control valve needs made. Only open the flow control valve enough to allow compressor to build to 145psi tank pressure read at the gauge on compressor tank. Opening the flow control too far could cause over speeding and reduced service life of the compressor. The liquid filled gauge on the hydraulic block will read the amount of hydraulic pressure (should be 2500-3000psi) Follow the instructions below to make the proper adjustment.

NOTE: Before making any adjustments to the flow control valve, adjust the tractor hydraulic flow fully open. Adjusting the tractor's hydraulic flow will affect the compressor's RPM. The hydraulic motor speed on the hydraulic compressor should not exceed 1350RPM. RPM's on the hydraulic compressor may be checked via the fan blades with an optical tachometer.

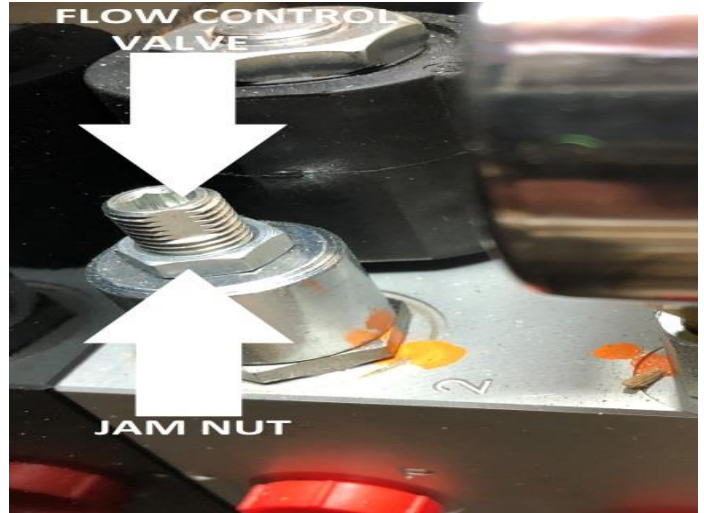
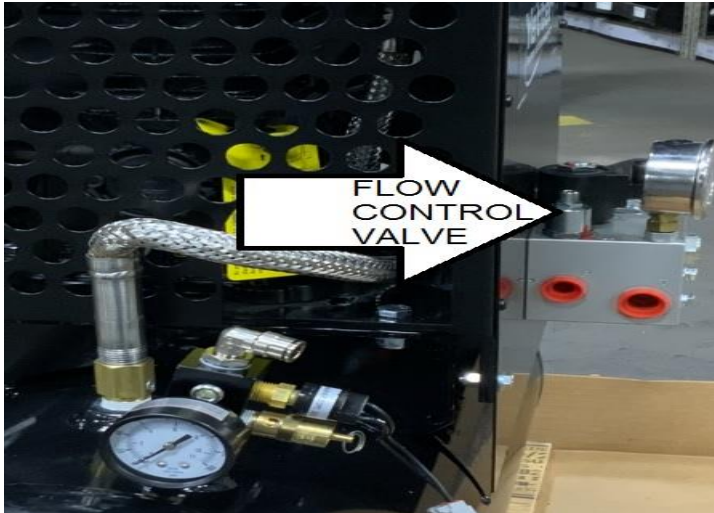

- STEP 1:** Engage the hydraulics to the compressor and press ACTIVATE SYSTEM icon.
- STEP 2:** Make adjustments while hydraulic motor is running or should be running. Open the tank drain to engage compressor if necessary.
- STEP 3:** Insert a 3/16 Allen wrench into flow control valve. Loosen jam nut by turning 1/2 wrench counterclockwise.
- STEP 4:** Using the Allen wrench, **SLIGHTLY** turn the flow control valve counterclockwise (the equivalent to 3 degrees or 1/32 of a turn) to increase the hydraulic motor speed.
- STEP 5:** Hold the Allen wrench in place and tighten the jam nut. Each time an adjustment is made, allow the compressor to build to its potential 145psi shut off mark. If 145psi is not achieved, drain tank pressure until compressor turns on, and make another adjustment. Repeat these steps until 145psi is achieved so that the compressor runs smoothly without struggle. **DO NOT RUN MOTOR ON COMPRESSOR MORE THAN 1350RPM!** RPMs can be checked with an optical tachometer using the fan blades. Once the flow control valve is set properly, hold the Allen wrench in place and tighten the jam nut.

Pre-Field Operation Guide

LEAK TESTING:

A leak testing procedure should be performed after set-up of the 2940 Air Adjust system is complete. This procedure shall be performed at the beginning of each planting season and every 20 hours of in season use. **In addition, it should be performed if the user notices a lack of air pressure availability or if the compressor is running an abnormally high duty cycle or run time.** It will help keep the duty cycle in check, thus extending the life of the compressor. The most efficient way to perform a leak test is to use shop air, if available, to allow for a quieter environment to detect an air leak better. A 2940-382 shop air adaptor is provided in the 2940-174 spare fittings bag. The shop air adaptor is equipped with a shut off valve. Attach your matching male coupler to the open 1/4"NPT & install airline between the 3/8PTC fitting & the water separator inlet port. Wrap the male threads of the shop air fitting with Teflon tape.



Pre-Field Operation Guide Con't

SYSTEM LEAK TESTING:

- Step 1:** Power the Yetter control box, connect tablet to "AIR ADJUST" WiFi & open Yetter app or if ISOUBS application, open Yetter run page on the ISOBUS VT, & press ACTIVATE SYSTEM. If using planters onboard compressor, make sure the compressor has run 1 complete cycle, and shut off to make sure there are no leaks at compressor & control box.
- Step 2:** With 0psi commanded to the RU, RD, & WT circuits, note the pressure on the compressor tank gauge. Start a stop watch & after 5 minutes, note the tank pressure. If tank pressure drops more the 5 psi, check for leaks around/inside the compressor housing, water separator, & control box. Repair as needed.
- Step 3:** Turn the lift pressure (RU) to 40psi, exit the tractor cab, & start at the compressor housing checking all blue airline on the RU circuit for air leaks. The row cleaners should be in the raised position. Check all fittings, tees, & airline on the RU circuit. Repair leaks as needed, return to the cab, & turn the lift pressure back to 0psi.
- Step 4:** Turn the down pressure (RD) & wheel track (WT) pressure to 40psi, exit the tractor cab, & start at the compressor housing checking all black airlines on the RD & WT circuit for leaks. The row cleaners should be firmly in the down position. Check all fittings, tees, & airline on the RD & WT circuits for air leaks. Repair leaks as need, return to the tractor cab, & turn all circuit pressures to 0psi.
- Step 5:** With 40psi commanded in the RU, RD, & WT circuits, note the pressure on the compressor tank gauge. Start a stop watch & after 5 minutes, note the tank pressure on gauge at the tank. If tank pressure drops more than 10psi, check for leaks on the row cleaner fittings, tees, and dump valves. Repair as needed.

AIR COMPRESSOR PRE-OPERATING TEST PROCEDURE:

Before beginning this test, run the compressor system leak test and ensure it passes. There should be virtually no leaks in the tank circuit before performing this test. Use a stop watch to time the hydraulic compressor's recovery time. Start time when tank gauge reaches 125psi & the compressor turns on. Stop the time when compressor shuts off at 145psi. If the time is greater than 20 seconds, there is a potential leak, the compressor is worn, or compressor's RPMs are too slow. Repair as needed.

Proper Settings

Air Pressure Settings

Residue Managers Only

A common question is "What pressures should I start out at?" A good starting pressure setting would be PRESET 2: 35psi Up Pressure (RU), 30psi Down Pressure (RD), & 32psi Wheel Track (WT). This particular setting will give each row cleaner a nice, sturdy float. If this pressure setting doesn't remove enough residue or trenches/digs furrows, adjust the settings accordingly until the row cleaner is doing exactly what you want it to do. If the row cleaner is trenching, move to a lighter preset, in this case, PRESET 1. If not enough residue is removed, move to a heavier preset, in this case, PRESET 3 – 5. Once a preset is found or is very close, fine tune the preset using the +/-1 icons. Each field may require a different setting even though field conditions seem the same. For example, if you use a setting for one no-till field planting corn in soybean residue, you may find that the setting used for the next field planting corn in soybean residue in no-till conditions may be different. The reason may be the amount of residue, soil types, moisture amounts, etc.

Renaming Presets

Presets can be edited 2 ways: target pressure & preset label. To help the operator better understand which preset to start out with, renaming the preset label to the planting condition is a good idea. Preset names have a 20 character max limit. If planting corn into corn stalks, a good name for the preset might be CORN ON CORN. If planting into a variety of tillage conditions, naming your presets for each condition might be best: NO TILL, STRIP TILL, CONVENTIONAL TILL, etc. Use the renaming of the presets to allow all operators to have a better understanding of the best starting point for the row cleaner pressures when entering a new field. 1 field that is no-till with soybean stubble may use different pressures than another field of no-till soybean stubble. Use +/-1 icon in each circuit to fine-tune the row cleaners to perform exactly how the operator wants them to. Make sure to press **SAVE** after all edits if wanting to keep.

#	LABEL	RU	RD	WT
1	YETTER LIGHTER	40	25	27
2	YETTER LIGHT	35	30	32
3	YETTER MEDIUM	30	35	37
4	YETTER HEAVY	35	45	45
5	YETTER HEAVIER	30	50	50

PRESET BEING SAVED: RU-30, RD-30, WT-20

SAVE TO PRESET:

PRESET LABEL:

#	LABEL	RU	RD	WT
1	YETTER LIGHTER	40	25	27
2	YETTER LIGHT	35	30	32
3	YETTER MEDIUM	30	35	37
4	YETTER HEAVY	35	45	45
5	YETTER HEAVIER	30	50	50

PRESET BEING SAVED: RU-30, RD-30, WT-20

SAVE TO PRESET:

PRESET LABEL:

Yetter Hydraulic Compressor Maintenance



WARNING:

Keep extremities out of the compressor housing when compressor is running, has potential to run, or recently shut off as there are rotating and high temperature parts that may cause injury. Always turn tractor off & disconnect power before performing any maintenance.

LUBRICATION:

The compressor is shipped empty of pump lubrication and needs oil added before operation. Provided is a 1 Liter bottle of grade 111 full synthetic. Add oil until oil level is seen half way up on the sight glass & then recheck oil level on the dipstick. Yetter part number for purchasing new bottle is 2940-550.

GUARDS:

Always ensure the housing and guards are in place during operation.

AIR FILTER CARTRIDGE:

Yetter part number 2940-549. Order as needed.

MAINTENANCE SCHEDULE GUIDE

DAILY

- Check oil level and fill as needed
- Check air filter cleanliness and clean/replace as needed
- Check hoses for fluid leaks and replace/fix as needed
- Check air lines for air leaks and replace/fix as needed
- Check component parts of the compressor for damage (pressure switch, cooling fan, gauge, etc)
- Open Tank Drain Valve (10 seconds) **(see illustration to the right)** to allow moisture to drain----->

Closed



Open

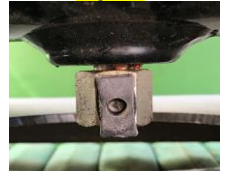

SEASONALLY/200 COMPRESSOR HOURS

- Change compressor oil
- Change inlet air filter
- Check fluid hoses and air lines for weakness or weathering and replace as needed.
- Check hydraulic fittings for proper connections with no leaks, replace as needed.

FIRST OIL CHANGE SHOULD TAKE PLACE AFTER APPROXIMATELY 50 RUNNING HOURS

CLEANING OR REPLACING THE 2940-106 AIR FILTER



Filter cleanliness is critical to maintain the performance & service life of the compressor. Recommendations for cleaning are DAILY & replace every 200 hours OR at beginning of every planting season. Dirt sucked passed the filter will ruin the pump.

STEP 1: Remove the wing nut, filter cover & filter. (If cleaning, tap the filter on a solid surface to remove dirt from the pleats & clean the filter base. **DO NOT USE COMPRESSED AIR TO CLEAN FILTER!**)

STEP 2: Install new or cleaned filter, filter cover, & wing nut removed in step 1. **TIGHTEN WING NUT SECURELY .**

REPLACING THE COOLING FAN

Remove the housing & hydraulic motor, loosen the LH bolt on the end of the shaft, use a pry bar to apply pressure to the back side of the fan while tapping on the LH bolt head until fan coupler is loose on the pump shaft, replace fan, tighten LH bolt, reinstall, the hydraulic motor & put the housing back on.

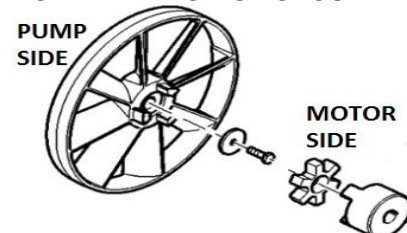

Yetter Hydraulic Compressor Maintenance

Check Hydraulic Air Compressor Oil

Deactivate SCV operating hydraulic compressor and turn tractor off before servicing

Check hydraulic air compressor oil daily before use during planting season and beginning of each season.

Sight glass is positioned behind the housing for protection purposes but easily seen without removing the housing. Oil level should be visible in sight glass. If oil needs added, remove housing and add grade 111 synthetic or PAO synthetic compressor oil until seen in middle of sight glass



Filling or Changing Hydraulic Air Compressor Oil

Deactivate SCV operating hydraulic compressor and turn off tractor before servicing

Filling Hydraulic Air Compressor Oil

Step 1: Remove cap

Step 2: Using a proper sized funnel add grade 111 synthetic or a PAO synthetic compressor oil until oil level is in middle of the sight glass

Step 3: Install cap

Changing Hydraulic Air Compressor Oil

Step 1: Remove cap for ventilation while draining

Step 2: Place container in position to catch oil while draining

Step 3: Remove drain plug to allow oil to drain

Step 4: Install removed drain plug after oil drained in entirety

Step 5: Add grade 111 synthetic or a PAO synthetic compressor oil until oil level is in middle of the sight glass

Step 6: Install cap



Remove housing to add or fill the pump with oil. See [page 22](#) for housing removal instructions.

2940-103A Control Box Maintenance

Daily when used – clean dirt/debris from inside of box, inspect all parts for damage/leaks & replace as needed.

Bearing Maintenance/Assembly

Practice Safety

Understand & practice safe service procedures before doing work. Follow ALL the operating, maintenance, & safety information in the equipment operator manual. Clear the area of bystanders, especially small children, when performing any maintenance or adjustments. Keep work area clean & dry. Use adequate lighting for the job. Use only tools, jacks, & hoists of sufficient capacity for the job. Never lubricate, service, or adjust machine while it is moving. Keep hands, feet, & clothing from power-driven moving and rotating parts. Disengage all power & operating controls to relieve pressure. Lower equipment to the ground or to the cylinder stops & turn off the engine. Remove the key. Wait for all moving parts to stop before servicing, adjusting, repairing or unplugging. Securely support any machine elements with blocks or safety stands that must be raised for service work. Keep all parts in good condition & properly installed. Fix damaged equipment immediately. Replace worn or broken parts. Remove any buildup of grease, oil, or debris. Make sure all guards are in place & properly secured when maintenance work is completed.



CAUTION: To help prevent serious injury or death to you or others caused by unexpected movement, service machine on a level surface. Lower machine to ground or sufficiently lock or block raised machine before servicing. If machine is connected to tractor, engage parking brake & place transmission in "PARK", shut off engine and remove key. If machine is detached from tractor, block wheels & use shop stands to prevent movement.



CAUTION: Use grease based on NLGI consistency numbers and the expected air temperature range during the service interval. Use a multi-purpose lithium, water resistant, moderate speed, & NLGI grade #2 grease. Other greases may be used if they meet the following NLGI Performance Classification: GC-LB.

Some types of grease thickener are not compatible with others. Consult your grease supplier before mixing different types of grease.

Maintenance

Lubrication

Yetter uses a high temperature, polyurea grease when assembling product at the factory. New wheel assemblies from Yetter will come prefilled with grease. **DO NOT** mix different types of grease. Doing so will cause the mixture to harden & will not release any oil or the mixture will soften releasing all the oil. In either case, there is effectively no lubrication.

Alternative Lubricants

Conditions in certain geographical areas may require special lubricants & lubrication practices which don't appear in the operator's manual. If there are any questions, consult Yetter Manufacturing Co. to obtain latest information & recommendation.

PART #	DESCRIPTION	OUNCES OF GREASE
2967-404	13" TAPER TOOTH R.M. WHEEL	1.12 OZ
2967-602	13" SHARK TOOTH R.M. WHEEL	1.12 OZ
2967-186	FLOATER WHEEL KIT W/R.M. WHEEL	2.08 OZ
2967-596	HEAVY DUTY OR BEVEL R.M. WHEEL W/ FLOATER WHEEL KIT	2.40 OZ

Storing Lubricants

Store them in an area protected from dust, moisture, & other contaminants.

Your machine can operate at top efficiency only if clean lubricants are used.

Use clean containers to handle all lubricants.

Bearing Replacement Installation (2021 – Older Bearing Assemblies)

1. When assembling the wheels, bearing assembly and hubcap, be sure to align the grease transfer hole in the spoke wheel with the groove in the hubcap and hole in the hub to allow grease passage.
2. Assemble the wheels, hubs and caps.
3. Grease the wheel/hub/bearing assembly. **DO NOT OVERFILL WITH GREASE AS COULD POP THE SEAL OUT.**

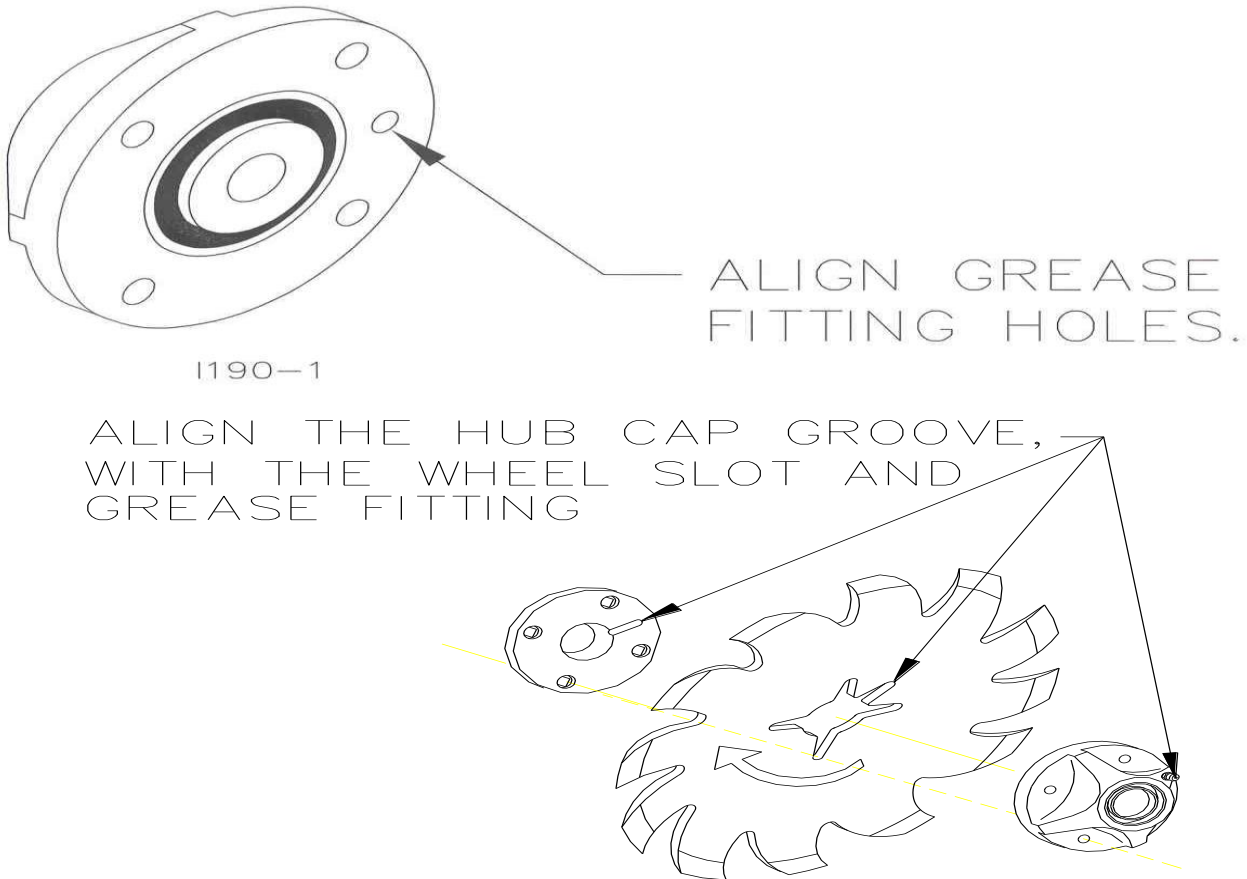

Be certain to align the grease fitting with the slot in the wheel and the hubcap so that the grease can flow freely to the cavity. The bearing is sealed but the cavity must be filled so that dirt, moisture, and debris do not enter the cavity and ruin the seal.

Maintenance

Lubrication Symbols

Lubricate with grease at hourly interval indicated on symbol.

Lubrication Intervals

Residue Manager (2021 – Older Hub/Bearings)

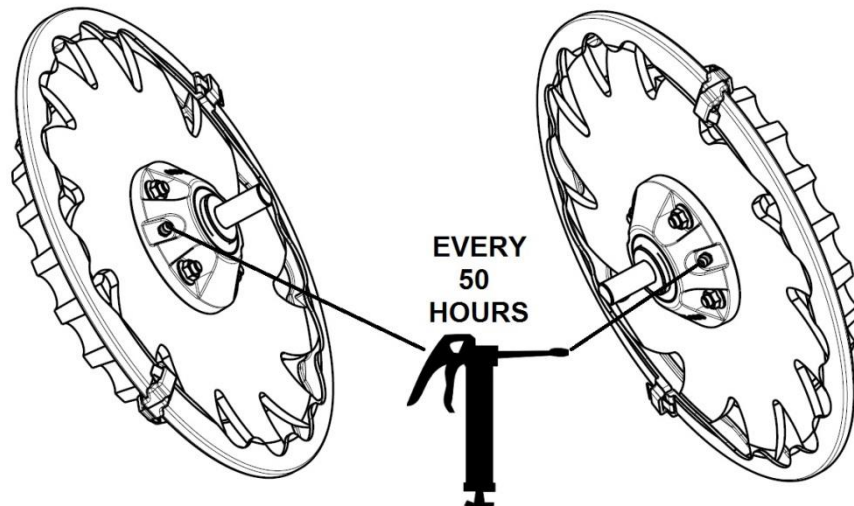

The recommended service intervals are based on normal conditions; severe or unusual conditions may require more frequent lubrication.

- Perform each lubrication and service procedure at the beginning and end of each season.
- Clean grease fittings before using grease gun, to avoid injecting dirt and grit into the bearing.
- Replace any lost or broken fittings immediately. If a fitting fails to take grease, remove and clean thoroughly, replace fitting if necessary. Also check for failure of adjoining parts.

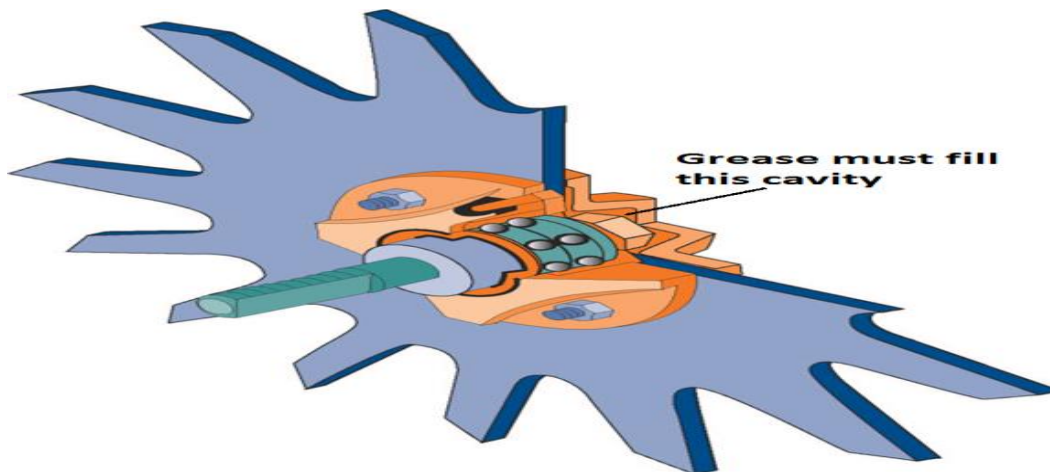

Storing the Equipment

- Store the machine in an area away from human activity in the **RAISED** position.
- Install service locks on all wheel cylinders.
- At the end of the season, the machine should be thoroughly inspected and prepared for storage. Repair or replace any worn or damaged components to prevent down time at the start of the next season. Store the machine under cover with all parts in operating condition.

- Clean machine thoroughly removing all dirt, debris, and crop residue which holds moisture causing rust.
- Inspect machine for worn or broken parts. See your Yetter Farm Equipment dealer during the off-season so that parts or service can be acquired when machine is not needed in the field.
- Lubricate bearings as outlined in the Lubrication section.
- Paint all parts which are chipped or worn and require repainting.
- Store machine in a clean, dry place with the planting unit out of the sun.

- If the machine cannot be stored inside, cover with a waterproof tarpaulin and tie securely in place.
- Do not allow children to play on or around the machine.

PARTS IDENTIFICATION – 2966-004

2966-004-
L-STFW

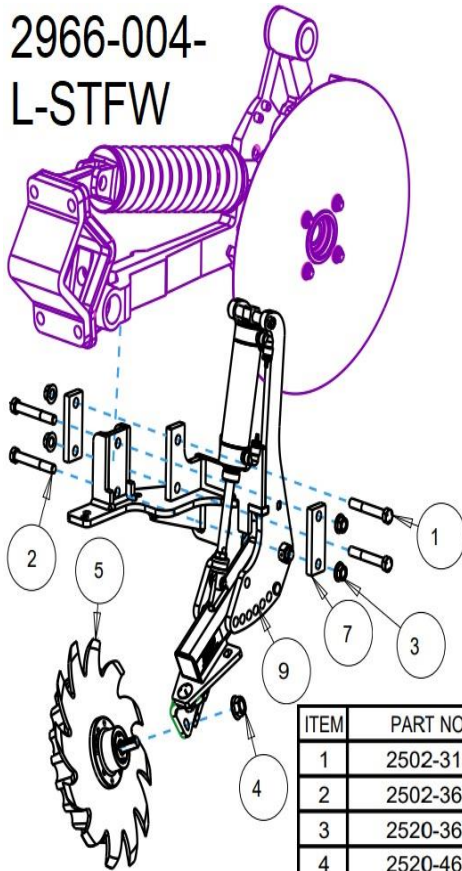

Other wheel options
available – see [page 43](#)

ITEM	PART NO.	DESCRIPTION	QTY
1	2502-316	1/2-13 X 3-1/2 HHCS GR5 ZP	2
2	2502-365	1/2-13 X 3-3/4 HHCS GR5 ZP	2
3	2520-361	1/2-13 FLANGE WHZLCK HXNT, GR 5, ZP	4
4	2520-465	5/8-11 WHIZLOCK HEX NUT, GR 8, ZP	1
5	2966-140-ST-FW	SHRKTH ASSY,RH,3"D-BOLT FLT WL	1
6	2966-141-ST-FW	SHRKTH ASSY,LH,3"D-BOLT FLT WL	1
7	2966-436	CLAMP PLATE	2
8	2966-910	AIR ADJUST SUB-ASSY,RH	1
9	2966-911	AIR ADJUST SUB-ASSY, LH	1

2966-004-
R-STFW

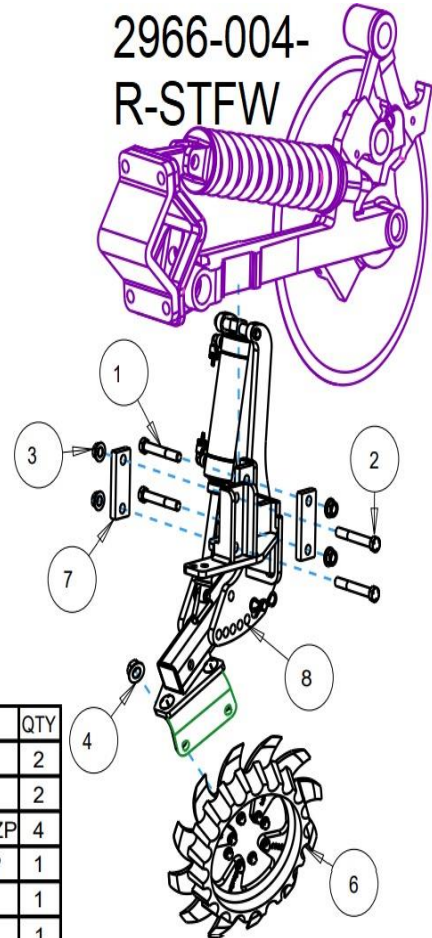

PARTS IDENTIFICATION – 2966-908

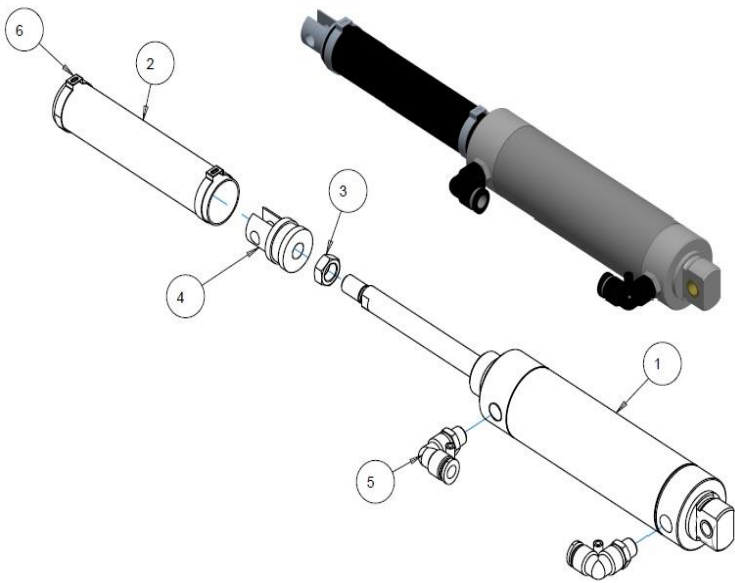

Item	Part #	Description	Qty
1	2515-849	PNEUMATIC CYLINDER, 2 X 4.5	1
2	2515-851	PROTECTIVE SLEEVE	1
3	2520-369	½ - 20 JAM HEX NUT GR A ZP	1
4	2529-509	CLEVIS	1
5	2940-408	3/8PC X 1/4NPT 90 DEGREE ELBOW	2
6	2966-439	EAR CLAMP	2

PARTS IDENTIFICATION (2021-NEWER HUB)

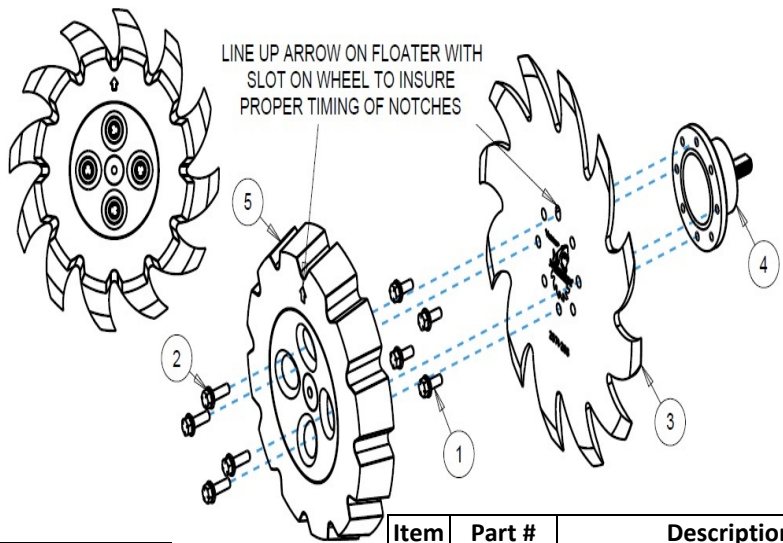
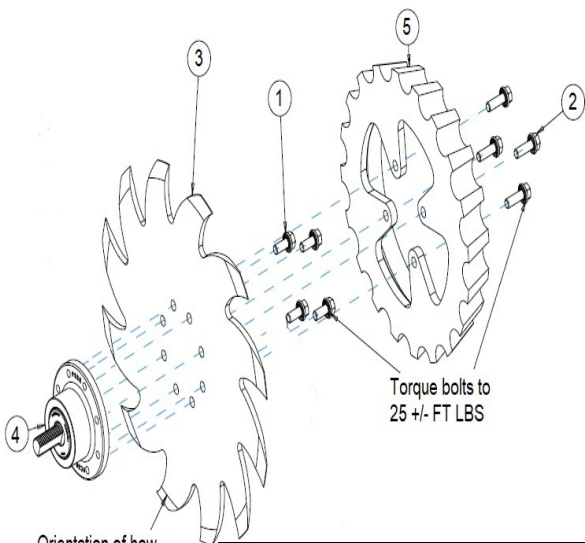

Orientation of how wheel is assembled determines RH or LH assembly

Item	Part #	Description	Qty
1	2502-220	5/16-18 X ¾ HHFS GR5 ZP	4
2	2502-221	5/16-18 X 1 HHFS GR5 ZP	4
3	2571-286	SHARKTOOTH WHEEL, 8 BOLT	1
4	2965-500	HUB ASSEMBLY, 1.406 SPINDLE	1
5	2967-560	FLOATER WHEEL	1

Item	Part #	Description	Qty
1	2502-220	5/16-18 X ¾ HHFS GR5 ZP	4
2	2502-221	5/16-18 X 1 HHFS GR5 ZP	4
3	2571-286	SHARKTOOTH WHEEL, 8 BOLT	1
4	2965-500	HUB ASSEMBLY, 1.406 SPINDLE	1
5	2967-957	ST TIMED FLOATER WHEEL	1

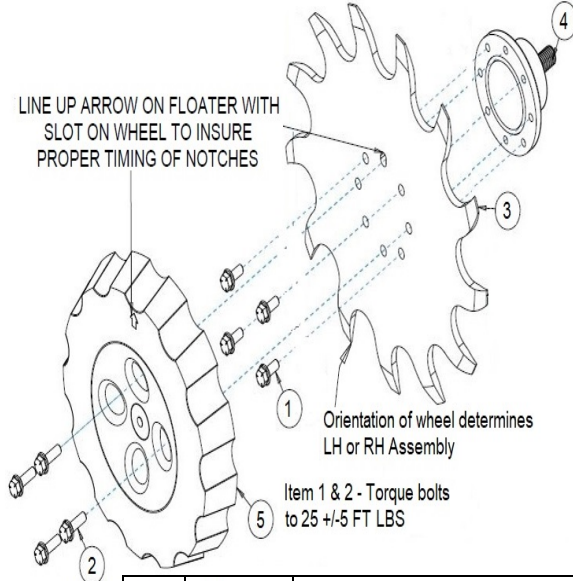
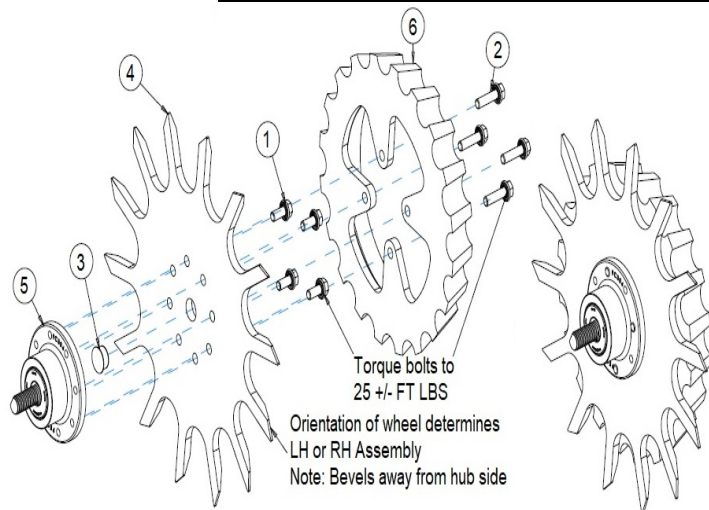

Item	Part #	Description	Qty
1	2502-220	5/16-18 X ¾ HHFS GR5 ZP	4
2	2502-222	5/16-18 X 1 ¼ HHFS GR5 ZP	4
3	2571-286	SHARKTOOTH WHEEL, 8 BOLT	1
4	2571-287-R	13" BEVEL WHEEL, 8 BOLT, RH	1
	2571-287-L	13" BEVEL WHEEL, 8 BOLT, LH	1
5	2965-500	HUB ASSEMBLY, 1.406 SPINDLE	1
6	2967-560	FLOATER WHEEL	1

Item	Part #	Description	Qty
1	2502-220	5/16-18 X ¾ HHFS GR5 ZP	4
2	2502-221	5/16-18 X 1 HHFS GR5 ZP	4
3	2571-600	SHARKTOOTH FINGER WHEEL	1
4	2965-500	HUB ASSEMBLY, 1.406 SPINDLE	1
5	2967-955	STF TIMED FLOATER WHEEL	1

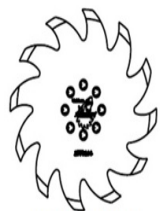

SHARKTOOTH WHEEL ASSEMBLY
RH - 2966-140-ST (SHOWN)
LH - 2966-141-ST



SHARKTOOTH WITH FLOATER WHEEL ASSEMBLY
RH - 2966-140-ST-FW (SHOWN)
LH - 2966-141-ST-FW



SHARKTOOTH WITH POLY FLOATER WHEEL ASSEMBLY
RH - 2966-140-ST-PFW (SHOWN)
LH - 2966-141-ST-PFW

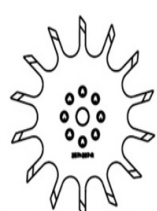

BEVEL WHEEL ASSEMBLY
RH - 2966-140-BW (SHOWN)
LH - 2966-141-BW



BEVEL WHEEL W/ FLOATER WHEEL ASSEMBLY
RH - 2966-140-BW-FW (SHOWN)
LH - 2966-141-BW-FW

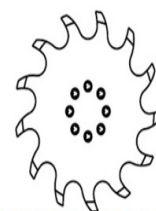

SHARKTOOTH FINGER WHEEL ASSEMBLY
RH - 2966-140-STF (SHOWN)
LH - 2966-140-STF



SHARKTOOTH FINGER W/ FLOATER WHEEL ASSEMBLY
RH - 2966-140-STF-FW (SHOWN)
LH - 2966-141-STF-FW

PARTS IDENTIFICATION

(OLD 4 BOLT WHEELS USING NEW HUB/BEARING)

FIELD SERVICE KITS

- 2965-119 - SERVICE KIT FOR 2570-740-2.812 D-BOLT
- 2965-120 - SERVICE KIT FOR 2570-742-3.812 D-BOLT
- 2965-121 - SERVICE KIT FOR 2570-766-2.562 D-BOLT

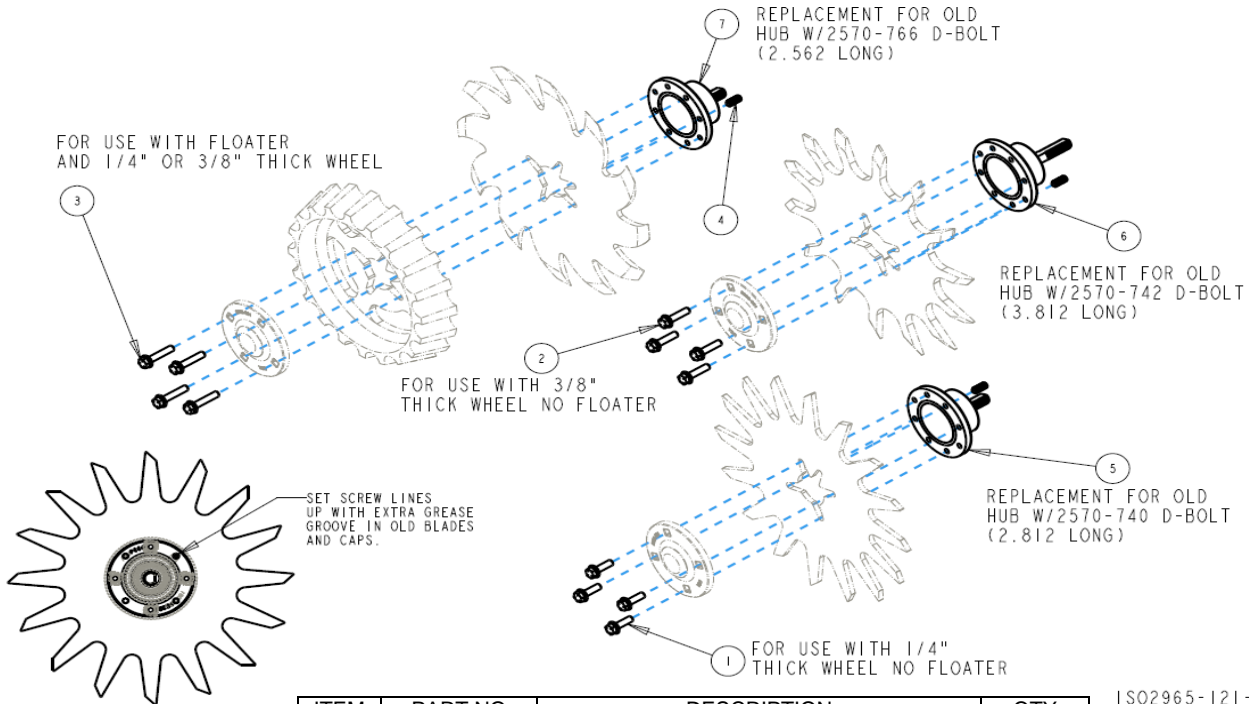

ITEM	PART NO	DESCRIPTION	QTY
1	2502-221	5/16-18 X 1 HHFS GRADE 5	4
2	2502-222	5/16-18 X 1-1/4 HHFS GRADE 5	4
3	2502-225	5/16-18 X 1-1/2 HHFS GRADE 5	4
4	2940-560	SET SCREW	1
5	2965-500	HUB ASSEMBLY 1.406 SPINDLE	1
6	2965-501	HUB ASSEMBLY 2.406 SPINDLE	1
7	2965-502	HUB ASSEMBLY 1.157 SPINDLE	1

ISO2965-121-2

2020-OLDER WHEEL & HUB/BEARING ASSEMBLY

ORIENTATION OF TOOTHED WHEEL DETERMINES LH/RH

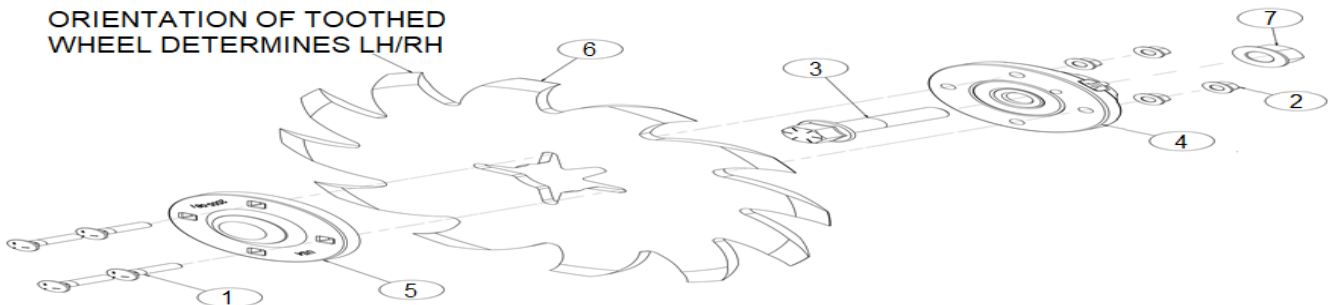

ITEM	PART NO	DESCRIPTION	QTY
1	2505-207	5/16-18 X 1-1/4 CARRIAGE HEAD BOLT GRADE 5	4
2	2520-206	5/16-18 FLANGE LOCK NUT	4
3	2570-740	D-BOLT FLANGE HEAD 5/8-11 X 2.812 GRADE 8	1
4	2965-128	HUB/BEARING ASSEMBLY	1
	2550-069	SEAL	1
	2570-594	BEARING	1
	2570-715	INSERT	1
	2965-351	HUB	1
	2533-110	GREASE FITTING	1
5	2965-352	HUB CAP	1
6	2967-602	SHARK TOOTH WHEEL	1
7	2520-465	5/8-11 FLANGE LOCK NUT GRADE 8	1

PARTS IDENTIFICATION – 2966-910 – RH ASSEMBLY

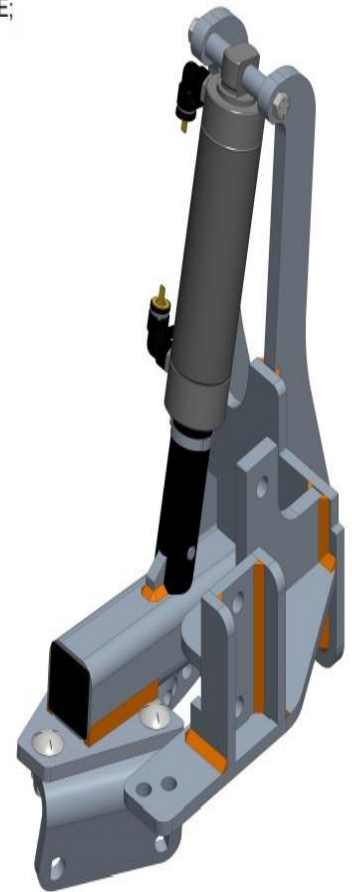
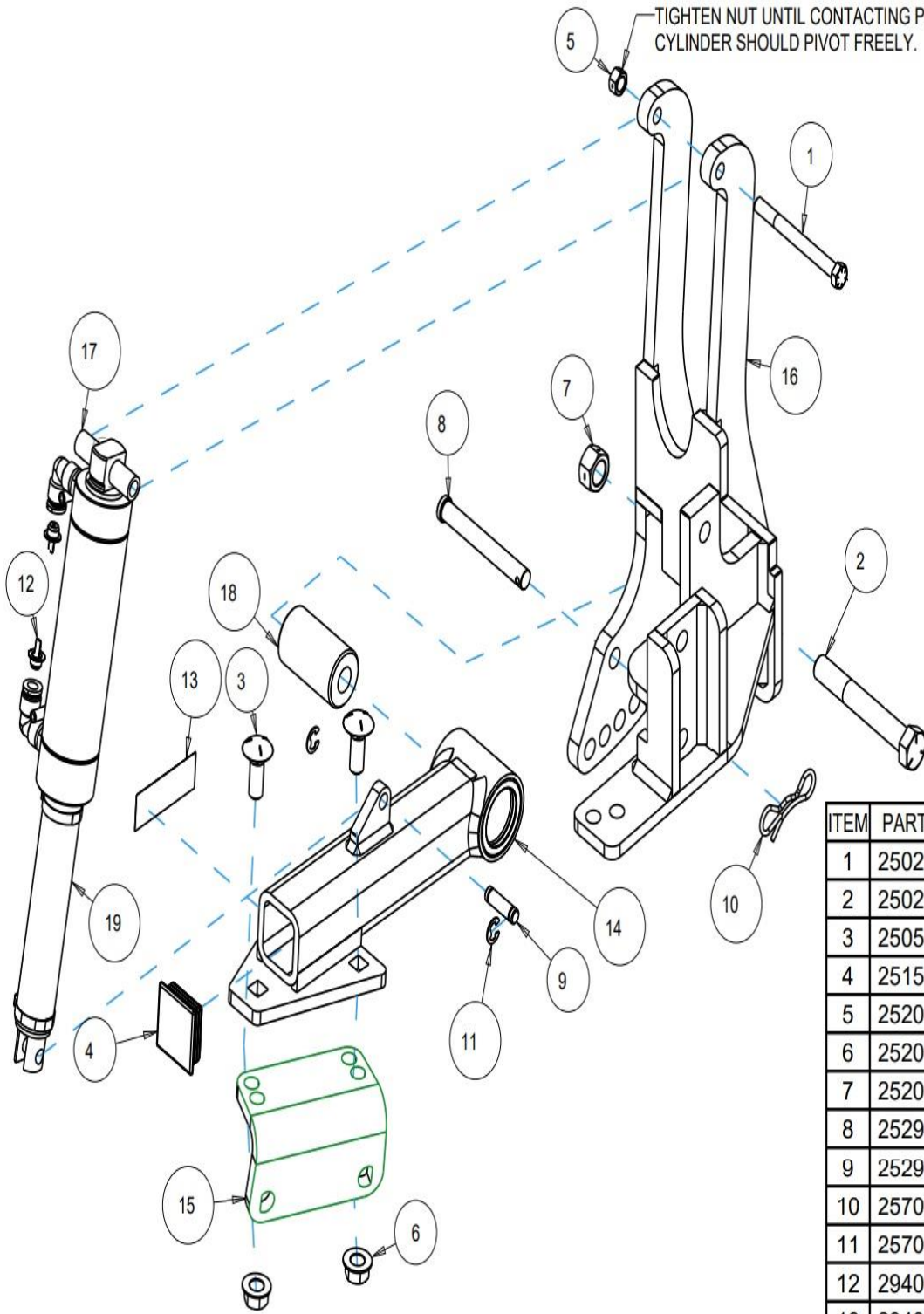

ITEM	PART NO.	DESCRIPTION	QTY
1	2502-264	3/8-16 X 4 HHCS GR 8 ZP	1
2	2502-334	5/8-11 X 4-1/2 HHCS GR5 ZP	1
3	2505-337	1/2-13 X 1 1/4 CARBLT G5ZP	2
4	2515-850	PLASTIC CAP	1
5	2520-255	3/8-16 LOCK HEX NUT, GR A, ZP	1
6	2520-361	1/2-13 FLANGE WHZLCK HXNT, GR 5, ZP	2
7	2520-459	5/8-11 LOCK HEX NUT, GR B, ZP	1
8	2529-508	CLEVIS PIN, .5 X 3.75 USABLE	1
9	2529-510	CLEVIS PIN	1
10	2570-448	.120 BOWTIE LOCKING COTTER ZP	1
11	2570-577	EXTERNAL RETAINING RING	2
12	2940-389	RUBBER AIR BAG PLUG	2
13	2940-589	YETTER DECAL	1
14	2966-2008	ARM W.A.	1
15	2966-2010	WHEEL MOUNT W.A.	1
16	2966-2012	MOUNT W.A., RH	1
17	2966-428	PIVOT BUSHING	2
18	2966-435	PIVOT BUSHING, CHROME PLATED	1
19	2966-909	CYLINDER ASSEMBLY	1

PARTS IDENTIFICATION – 2966-911 – LH ASSEMBLY

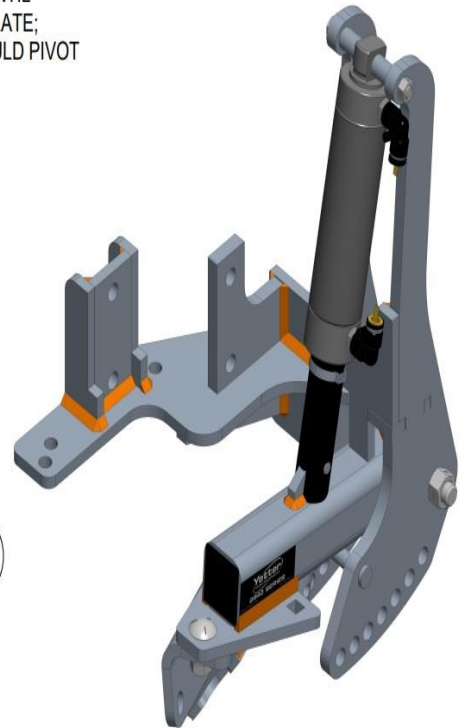
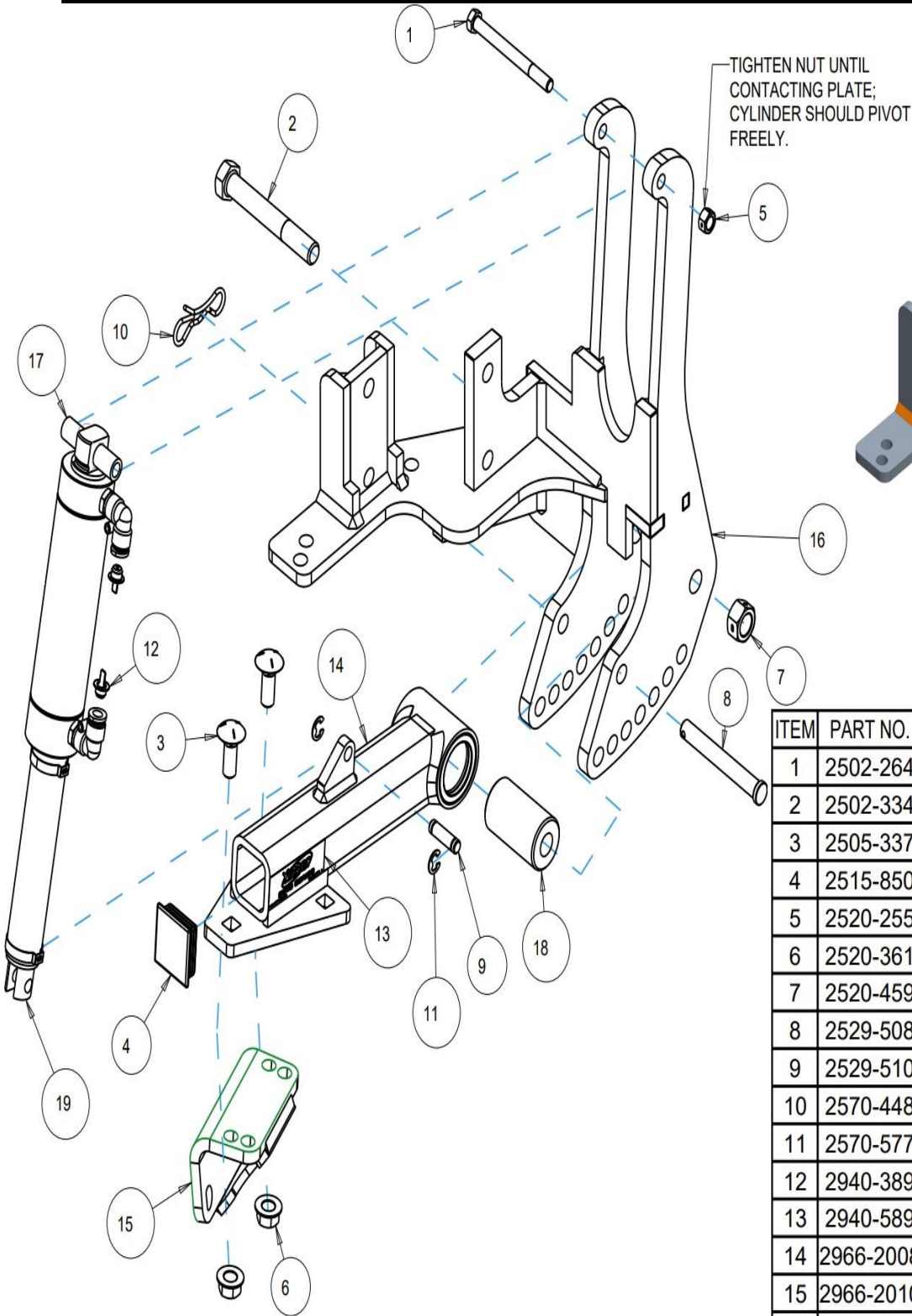

ITEM	PART NO.	DESCRIPTION	QTY
1	2502-264	3/8-16 X 4 HHCS GR 8 ZP	1
2	2502-334	5/8-11 X 4-1/2 HHCS GR5 ZP	1
3	2505-337	1/2-13 X 1 1/4 CARBLT G5ZP	2
4	2515-850	PLASTIC CAP	1
5	2520-255	3/8-16 LOCK HEX NUT, GR A, ZP	1
6	2520-361	1/2-13 FLANGE WHZLCK HXNT, GR 5, ZP	2
7	2520-459	5/8-11 LOCK HEX NUT, GR B, ZP	1
8	2529-508	CLEVIS PIN, .5 X 3.75 USABLE	1
9	2529-510	CLEVIS PIN	1
10	2570-448	.120 BOWTIE LOCKING COTTER ZP	1
11	2570-577	EXTERNAL RETAINING RING	2
12	2940-389	RUBBER AIR BAG PLUG	2
13	2940-589	YETTER DECAL	1
14	2966-2008	ARM W.A.	1
15	2966-2010	WHEEL MOUNT W.A.	1
16	2966-2011	MOUNT W.A., LH	1
17	2966-428	PIVOT BUSHING	2
18	2966-435	PIVOT BUSHING, CHROME PLATED	1
19	2966-909	CYLINDER ASSEMBLY	1

PARTS IDENTIFICATION

2940-082
5X7 & 7X7 BAR MOUNT KIT

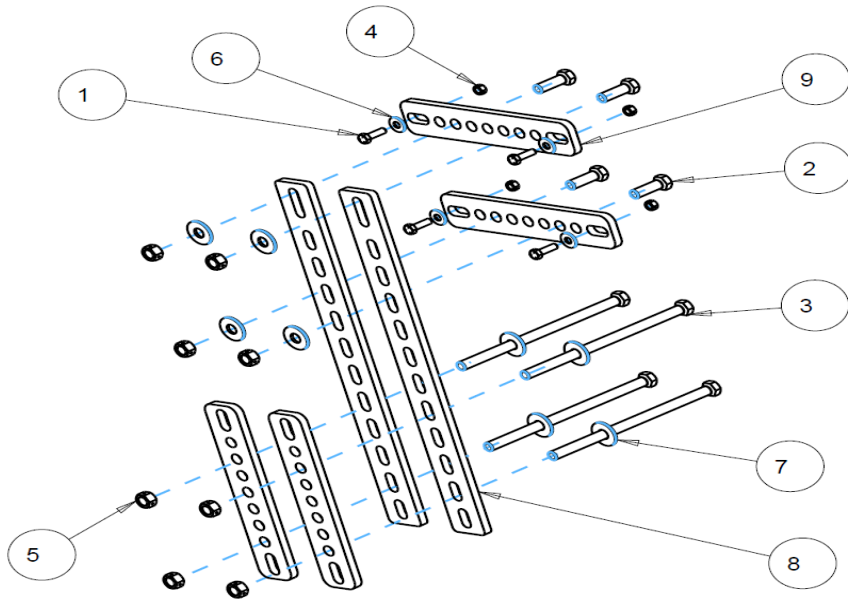

2940-082

Item	Part #	Description	Qty
1	2502-198	5/16-18 X 1 HHCS GR 5 ZP	4
2	2502-294	1/2-13 X 1-1/2 HHCS GR 5 ZP	4
3	2502-372	1/2-13 X 6 1/2 HHCS GR5 ZP	4
	2502-374	1/2-13 X 9 HHCS GR 5 ZP	4
4	2520-205	5/16-18 LOCK HEX NUT ZP	4
5	2520-357	1/2-13 LOCK HEX NUT ZP	8
6	2526-201	5/16 STANDARD FLAT WASHER ZP	4
7	2526-351	1/2 STANDARD FLAT WASHER ZP	8
8	2940-344	MOUNT STRAP (LONG)	2
9	2940-355	MOUNT STRAP (SHORT)	4

2940-083
8X16 & 8X12 BAR MOUNT KIT

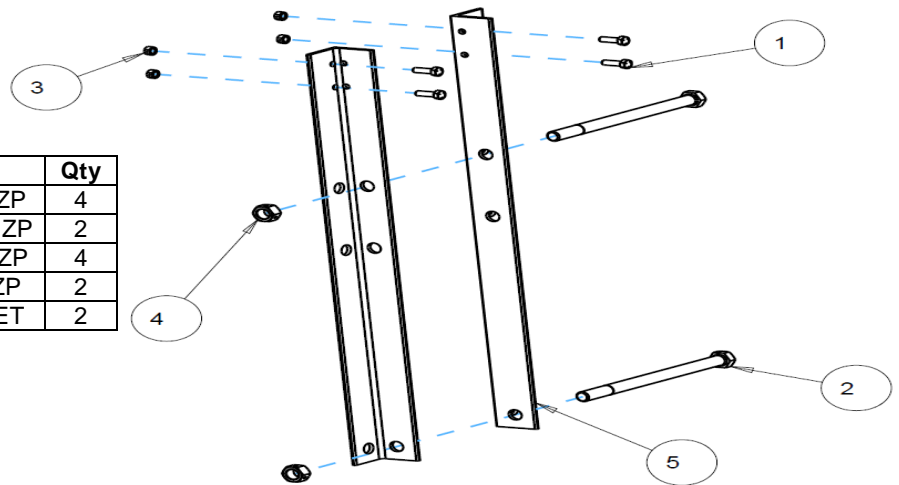

2940-083

Item	Part #	Description	Qty
1	2502-198	5/16-18 X 1 HHCS GR 5 ZP	4
2	2502-398	5/8-11 X 9 1/2 HHCS GR 5 ZP	2
3	2520-205	5/16-18 LOCK HEX NUT ZP	4
4	2520-459	5/8-11 LOCK HEX NUT ZP	2
5	2940-479	ANGLE MOUNT BRACKET	2

2940-084
UNIVERSAL HAND RAIL MOUNT KIT

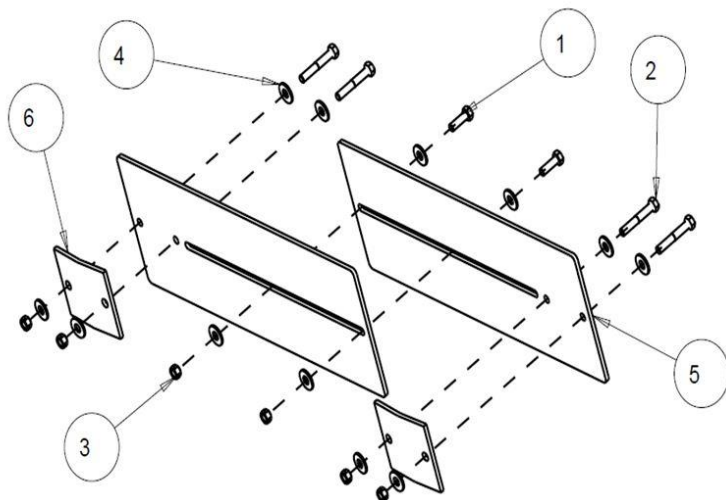

2940-084

Item	Part #	Description	Qty
1	2502-198	5/16-18 X 1 HHCS GR 5 ZP	7
2	2502-207	5/16-18 X 2 HHCS GR 5 ZP	4
	2502-212	5/16-18 X 2 1/2 HHCS GR5 ZP	4
3	2520-205	5/16-18 LOCK HEX NUT ZP	11
4	2526-201	5/16 STANDARD FLAT WASHER ZP	18
5	2940-480	HAND RAIL TELESCOPING PLATE	2
6	2940-481	HAND RAIL CLAMP	2

PARTS IDENTIFICATION

2940-085 2 PT/UNIVERSAL COMPRESSOR MOUNT KIT

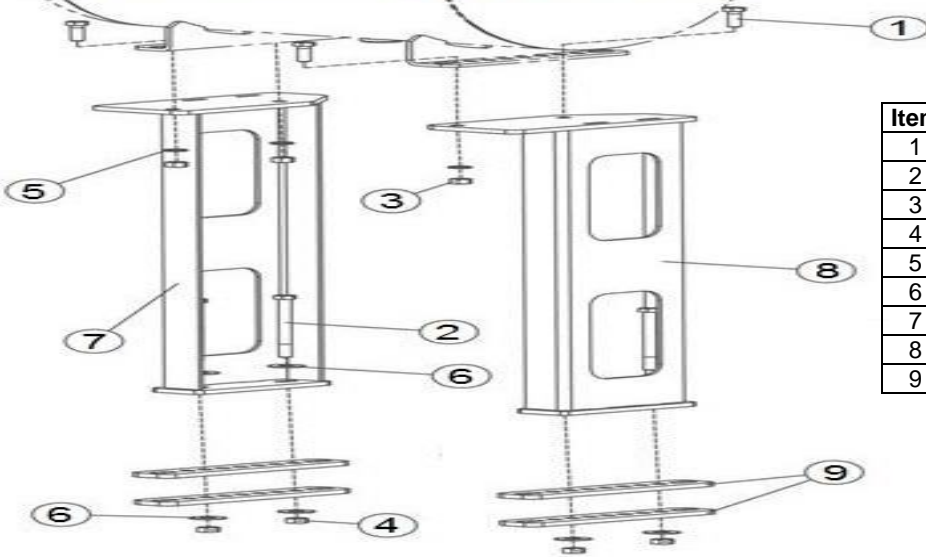

2940-085

Item	Part #	Description	Qty
1	2502-294	1/2-13 X 1 1/2 HHCS GR 5 ZP	4
2	2502-373	1/2-13 X 6 HHCS GR 5 ZP	4
3	2520-352	1/2-13 HEX NUT ZP	4
4	2520-357	1/2-13 LOCK HEX NUT ZP	4
5	2525-352	1/2 MED LOCK WASHER ZP	4
6	2526-352	1/2 SAE FLAT WASHER ZP	8
7	2940-207	COMPRESSOR MOUNT W.A., LH	1
8	2940-208	COMPRESSOR MOUNT W.A., RH	1
9	2940-355	MOUNT STRAP	4

2940-086

Item	Part #	Description	Qty
1	2502-294	1/2-13 X 1 1/2 HHCS GR 5 ZP	8
2	2502-349	1/2-13 X 5 FLTHD HHCS GR 5 ZP	4
3	2520-352	1/2-13 HEX NUT ZP	12
4	2525-352	1/2 MED LOCK WASHER ZP	12
5	2526-351	1/2 STANDARD FLAT WASHER ZP	24
6	2940-344	COMPRESSOR STRAP	2
7	2940-351	COMPRESSOR MOUNT BRACKET	4

2940-086 DRAFT TUBE/UNIVERSAL COMPRESSOR MOUNT KIT

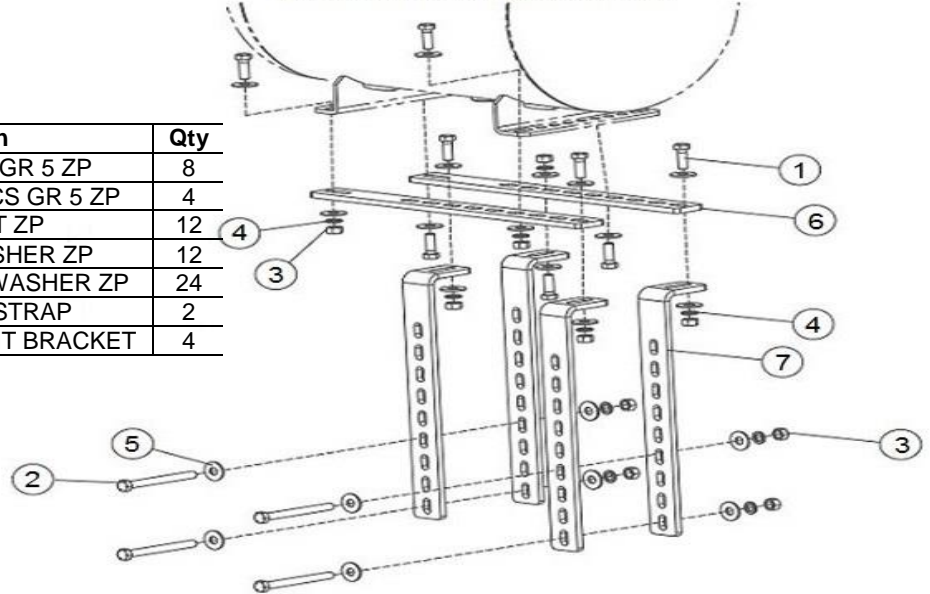

2940-090 8x12 & 2940-091 8x16 HYD COMP MOUNT KIT

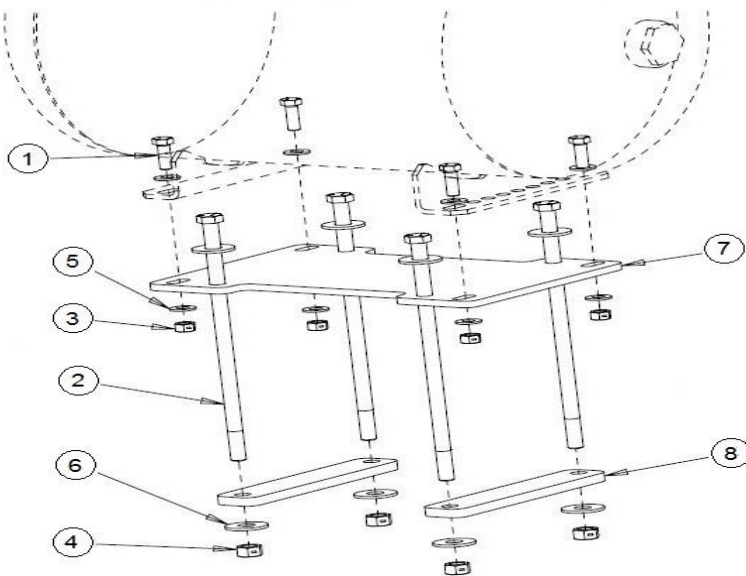

2940-090 & 2940-091

Item	Part #	Description	Qty
1	2502-294	1/2-13 X 1 1/2 HHCS GR 5 ZP	4
2	2502-388	5/8-11 X 14 HHCS GR 5 ZP (IN 2940-090 KIT)	4
	2502-389	5/8-11 X 18 HHCS GR 5 ZP (IN 2940-091 KIT)	4
3	2520-357	1/2-13 HEX LOCK NUT ZP	4
4	2520-459	5/8-11 HEX LOCK NUT ZP	4
5	2526-352	1/2 STANDARD FLAT WASHER ZP	8
6	2526-451	5/8 STANDARD FLAT WASHER ZP	8
7	2940-372	HYDRAULIC COMPRESSOR MOUNT PLATE	1
8	2940-373	MOUNT STRAP	2

2940-106 HYD COMP PARTS IDENTIFICATION

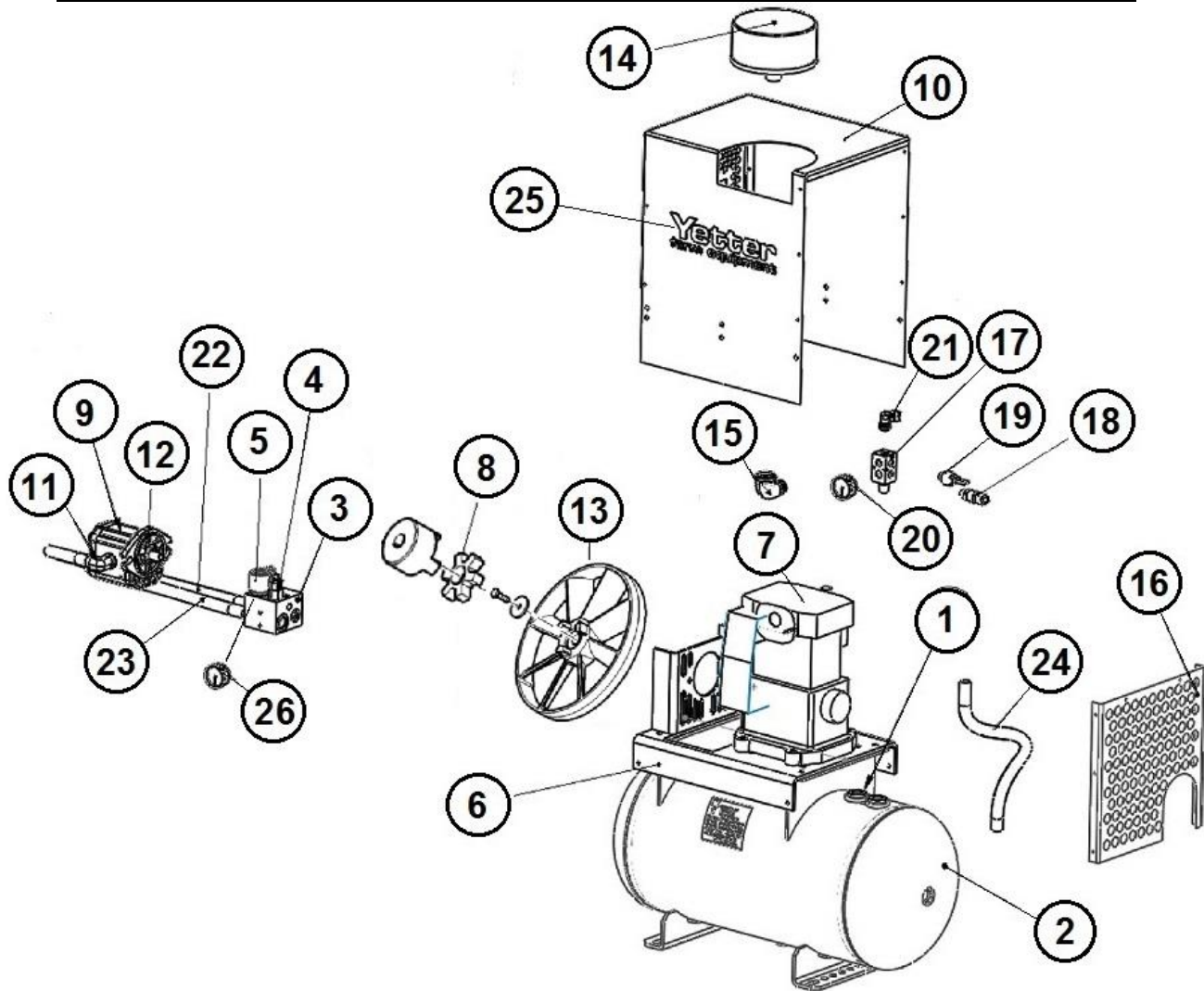

Item	Part Number	Description	Qty
1	N/A	CHECK VALVE	1
2	2940-440	12 GALLON TANK	1
3	2940-546	HYDRAULIC COMPRESSOR CONTROL BLOCK	1
4	N/A	FLOW CONTROL VALVE	1
5	2940-506	ON/OFF SOLENOID (COIL ONLY)	1
	2940-543	ON/OFF SOLENOID (CARTRIDGE VALVE)	1
6	N/A	FRAME	1
7	2940-545	ROL-AIR COMPRESSOR PUMP UNIT	1
8	2940-531	RUBBER SPIDER INSERT FOR LOVEJOY COUPLER	1
9	2940-554	HYDRAULIC MOTOR	1
10	N/A	HOUSING COVER	1
11	N/A	MOTOR ELBOW FITTING	1
12	N/A	INLET ELBOW FITTING	1
13	2940-519A	HYDRAULIC COMPRESSOR FAN, CAST (will fit on all Yetter Hyd. Compressors)	1
14	2940-549	HYDRAULIC COMPRESSOR AIR FILTER (FILTER ELEMENT ONLY)	1
15	N/A	FILTER ELBOW	1
16	N/A	BACK GUARD	1
17	N/A	AIR MANIFOLD	1
18	2940-416	175PSI TANK SAFETY RELIEF VALVE	1
19	2940-377	COMPRESSOR PRESSURE SWITCH 125-145PSI	1
20	2940-439	0-160PSI HYDRAULIC COMPRESSOR GAUGE	1
21	2940-635	3/8PTC X 3/8 NPT 90 DEGREE ELBOW FITTING, SWIVEL	1
22	N/A	TANK HOSE	1
23	N/A	INLET HOSE	1
24	N/A	PRESSURE LINE	1
25	2565-058	YETTER DECAL	1
26	2940-544	HYDRAULIC PRESSURE GAUGE WITH ADAPTER 0 – 5000PSI (LIQUID FILLED)	1

HYDRAULIC PUMP (2940-545) PARTS IDENTIFICATION

ROLAIR
SCHEMATIC FOR
PMP12MK103

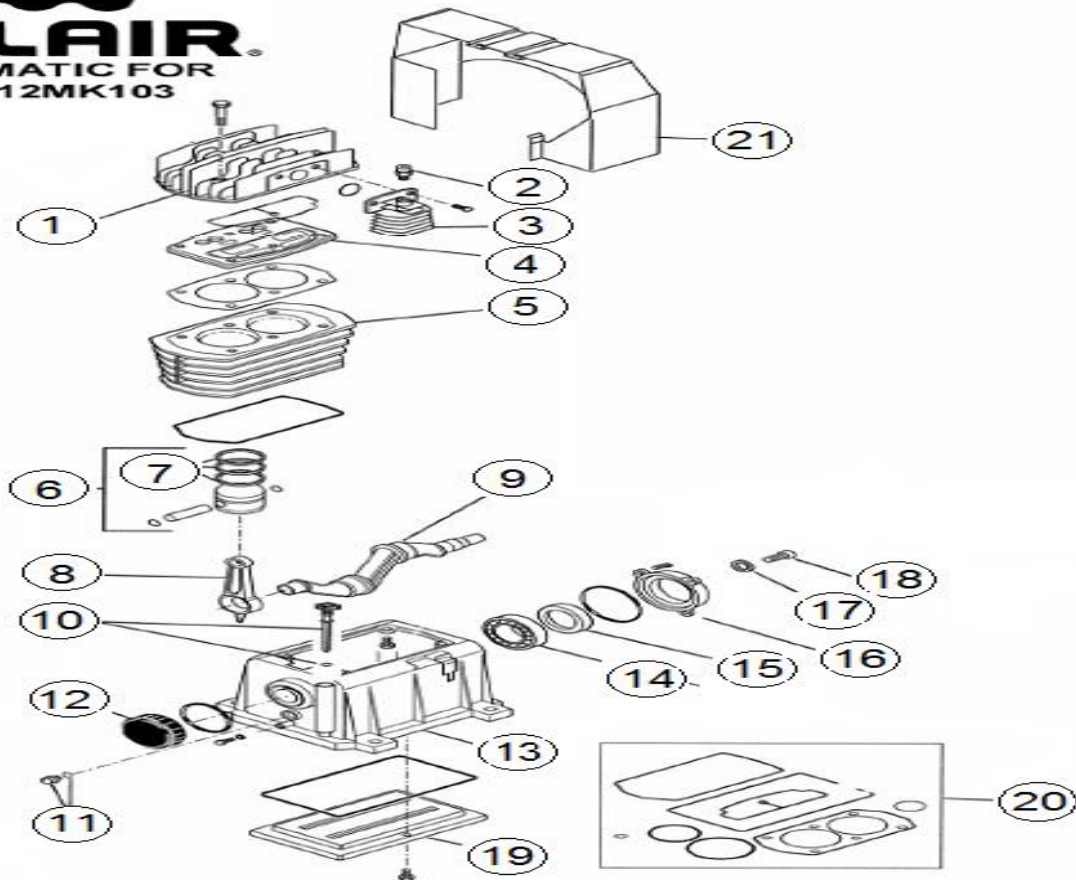

ROLAIR
S Y S T E M S

PARTS LIST FOR PMP12MK103

Schematic #	Description	Part #	Qty.
1	Head	FC113167020	1
2	Cold Start Valve	FC011158000	1
3	Aftercooler	FC116091024	1
4	Valve Plate Assembly	FC413167005	1
5	Cylinder	FC113167002	1
6	Complete Piston Assembly	FC413167006	2
7	Ring Set (2 required)	FC213167001	2
8	Connecting Rod	FC113150004	2
9	Crankshaft	FC113167003	1
10	Dipstick	FC312036000	1
11	Sight Gauge	FC012029000	1
12	End Cover	FC113149009	1
13	Crankcase	FC113167001	1
14	Ball Bearing	FC033027000	1
15	Oil Seal	FC010053000	1
16	Bearing Carrier	FC113149008	1
17	Washer	FC014005001	1
18	Bolt (Left-Hand Thread)	FC014001057	1
19	Lower Cover	FC113149015	1
20	Gasket Set	FC213167002	1
21	Shroud	FC113150002	1

PART REFERENCE ONLY

2940-103A PARTS IDENTIFICATION

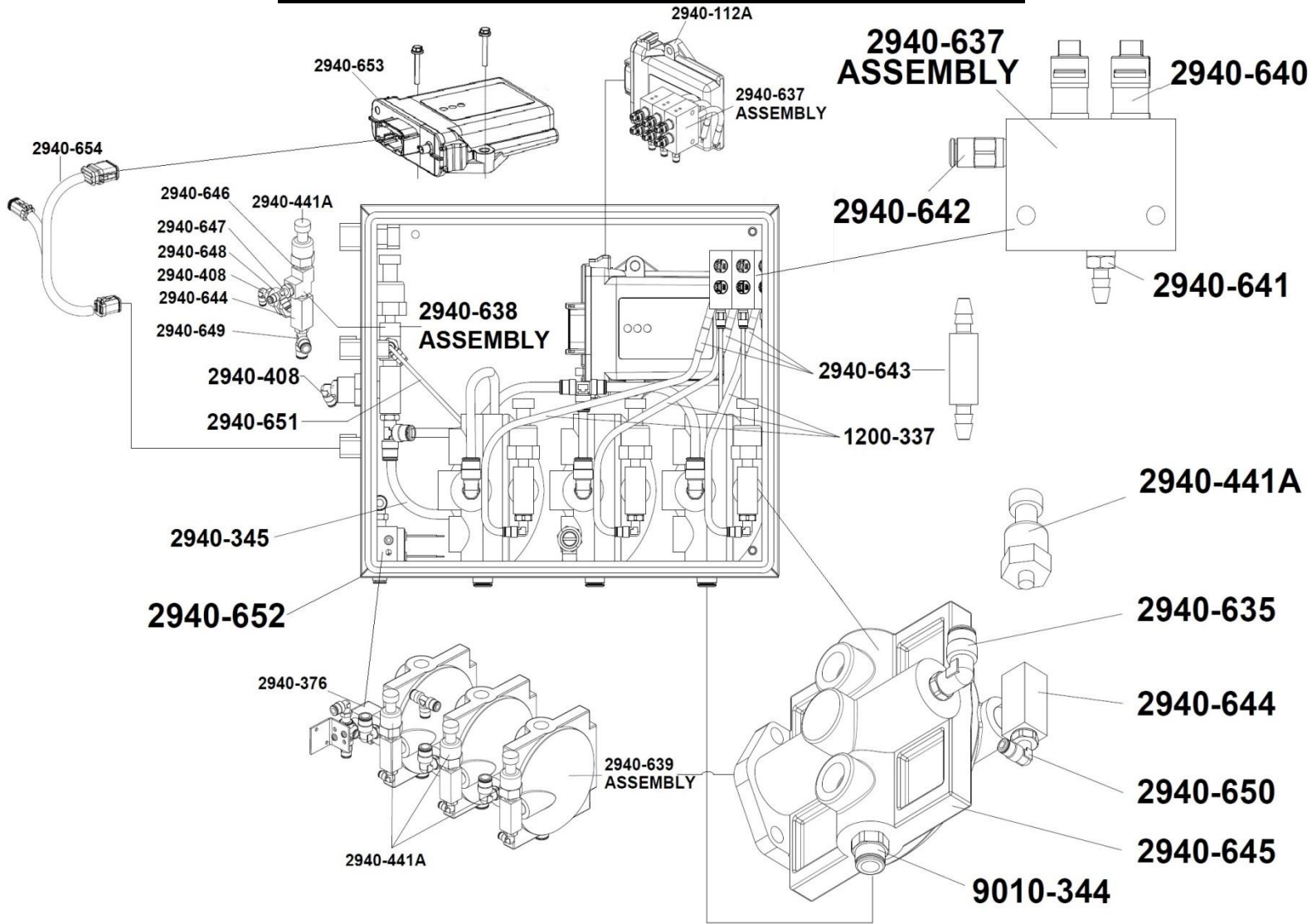

PART #	DESCRIPTION	QTY
1200-337	1/4 TUBING, 100FT ROLL, BLACK	1
2940-112A	12V MIDAC VDM	1
2940-345	3/8 TUBING, 100FT ROLL, BLACK	1
2940-376	WATER SEPARATOR DRAIN VALVE	1
2940-408	3/8PTC X 1/4NPT 90° ELBOW FITTING	1
2940-441A	0-200PSI PRESSURE TRANSDUCER W/ DEUTSCH	4
2940-635	3/8"PTC X 3/8NPT 90° ELBOW FITTING	3
2940-637	VALVE BLOCK ASSEMBLY	3
2940-638	INLET ASSEMBLY	1
2940-639	POR ASSEMBLY	3
2940-640	MAC BV VLAWE 2 WAY	6
2940-641	10-32 TO 1/4" TUBE BARB FITTING	3
2940-642	10-32 TO 1/4" TUBE PTC FITTING	3
2940-643	1/4" TUBE ORIFICE	3
2940-644	1/4" NPT TEE	4
2940-645	PILOT OPERATED REGULATOR	3
2940-646	1/4" NPT STREET ELBOW	1
2940-647	1/4"NPT TO 5/32" RUN TEE	1
2940-648	1/4" NPT BULKHEAD	1
2940-649	1/4NPT 3/8" RUN TEE	1
2940-650	1/4NPT TO 1/4" TUBE PTC ELBOW FITTING	3
2940-651	5/32 TUBING, BLACK	1
2940-652	12 X 14 X 8 ENCLOSURE	1
2940-653	THRASHER MODULE	1
2940-654	THRASHER TO MIDAC CONTROL HARNESS	1
9010-344	3/8PTC X 3/8NPTF STRAIGHT FITTING	3

2940-101A PARTS IDENTIFICATION

Item	Part #	Description	Qty
1	2940-416	175PSI TANK SAFETY RELIEF VALVE	1
2	2940-439	0-160PSI HYD. COMP. GAUGE, 1/4 NPT	1
3	N/A	AIR MANIFOLD	1
4	2940-635	3/8PC X 3/8NPT 90° ELBOW FITTING, SWIVEL	1
5	2940-336	HIGH PRESSURE RELIEF VALVE (NO FITTINGS)	1
	1200-323	1/4"PC TO 1/8NPT ELBOW	
6	2940-377	COMPRESSOR PRESSURE SWITCH 125-145PSI	1
7	2940-395	FILTER ELEMENT	1
8	2940-390	ELECTRIC COMPRESSOR	1
9	2940-391	COMPRESSOR RELAY	1
10	2940-440	12 GALLON TANK	1
11	N/A	1/4 TURN TANK DRAIN VALVE	1

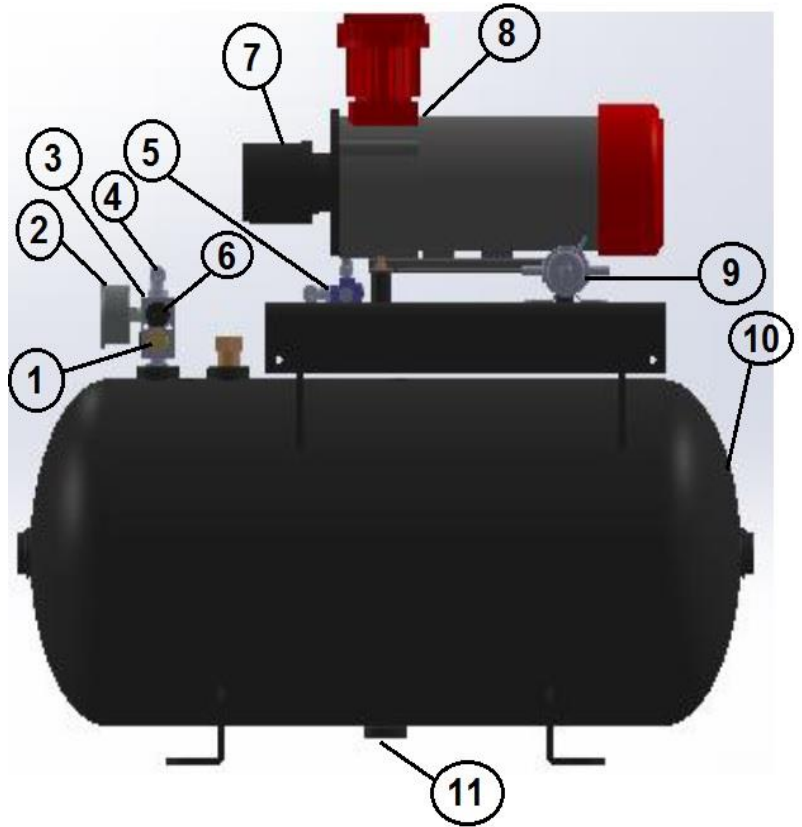

2940-136 PARTS IDENTIFICATION

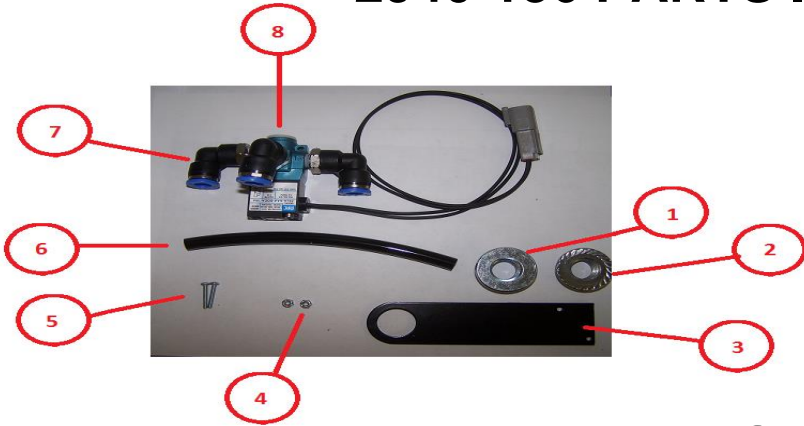

Item	Part #	Description	Qty
1	14M7291	METRIC FLANGE HEX NUT	1
2	2520-464	5/8-11 SERRATED FLANGE NUT	1
3	2940-335	DUMP VALVE MOUNT TAB	1
4	2520-110	M5 HEX LOCK NUT	2
5	N/A	PHILIPS HEAD BOLT	2
6	2940-138	6" 3/8 DRAIN AIRLINE	1
7	2940-337	3/8 PTC ELBOW 1/8NPT	3
8	2940-336	VALVE	1

2940-415 PARTS IDENTIFICATION

Item	Part #	Description	Qty
1	2940-663	SCREW, SEPARATOR TO MOUNTING BRACKET	2
2	Not Used	SCREW, WATER SEPARATOR TO REGULATOR	2
3	2940-664	MOUNTING BRACKET	1
4	2940-404	REGULATOR	1
5	2940-408	3/8PTC X 1/4NPT ELBOW AIR FITTING	2
6	2940-423	1/4PTC X 1/8NPT ELBOW AIR FITTING	1
7	2940-438	WATER SEPARATOR	1
8	2940-667	PRESSURE GAUGE, 1-160PSI, 1/8NPT	1

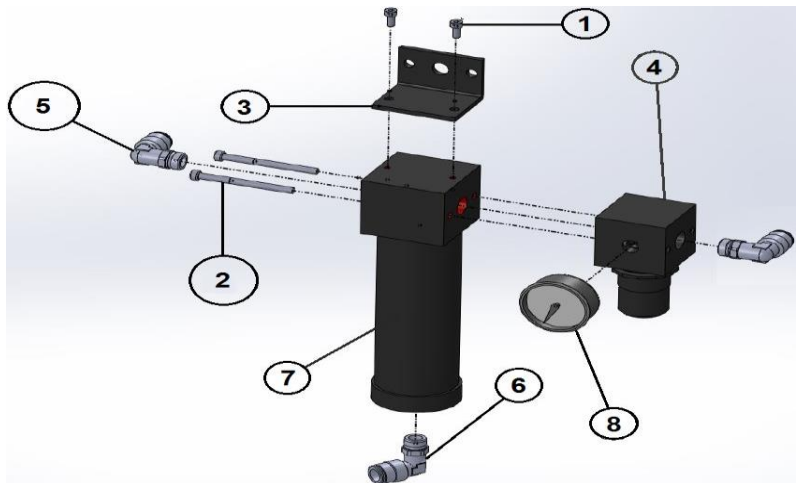

Troubleshooting Guide

Problem	Cause	Corrective Action
Tank pressure drops when compressor shuts off	<ol style="list-style-type: none"> 1. improper check valve function 2. loose connections/ air leak 3. water separator drain valve leaking 	<ol style="list-style-type: none"> 1. replace check valve on compressor 2. perform leak check (see pages 37) 3. replace water separator drain valve
Compressor runs continuously/air flow lower than normal, Compressor Run Time High warning on cab controller if compressor runs continuously for 15 minutes	<ol style="list-style-type: none"> 1. excessive air usage 2. loose connections/air leak 3. Improper pressure switch function 4. clogged air filter element 5. worn compressor 6. defective safety valve 7. tank drain valve open 8. water separator valve leaking 	<ol style="list-style-type: none"> 1. decrease air usage 2. perform leak check (see pages 37) 3. replace pressure switch 4. clean/replace filter element 5. replace compressor 6. replace safety valve 7. close tank drain valve 8. replace water separator valve
Compressor will not run	<ol style="list-style-type: none"> 1. air system is off 2. hydraulics disengaged 3. no power to control box 4. communication harness connection issue 5. shut off psi(145psi) reached 6. worn compressor 7. Improper pressure switch function 	<ol style="list-style-type: none"> 1. press ACTIVATE SYSTEM 2. engage compressor hydraulic circuit 3. check power connections from battery to control box, check 2940-166 breaker at battery 4. check harnessing from compressor to the control box 5. compressor will restart after tank pressure drops below 125psi 6. replace compressor 7. replace pressure switch
No air output from the RU, RD, and WT ports even though pressure is commanded and tank pressure reads 75psi or greater	<ol style="list-style-type: none"> 1. air system is off 2. no power to the VDM 3. 75psi of tank pressure not achieved 4. improperly functioning Mac Valves 5. communication harness connection issue 	<ol style="list-style-type: none"> 1. press ACTIVATE SYSTEM 2. check power connections from battery to VDM, check 2940-166 breaker at the battery 3. allow the compressor to build at least 75psi 4. replace Mac Valves as needed 5. check the end of all connectors to make sure terminal pins are all flush to the end of the male connectors and the connectors are seated tightly
Low or sporadic tank pressure reading Air leaking out regulator knob	water separator/regulator assembly plumbed incorrectly	plumb water separator/regulator correctly (air compressor→water separator→exit regulator side→enter control box inlet port)
Compressor struggles to build/won't build 145psi	flow control valve adjustment needed	flow control valve adjustment needed (see page 36 for instructions)
No connection to Thrasher or No connection between VDM & Thrasher	improper communication harness connection between VDM and Thrasher	<ol style="list-style-type: none"> 1. Make sure the lights on the Thrasher are laminated 2. Make sure 2940-654 Thrasher to Midac is plugged in
Excessive noise from compressor	<ol style="list-style-type: none"> 1. loose mounting bolts 2. worn bearings 3. cylinder or piston is worn 4. compressor over speeding 	<ol style="list-style-type: none"> 1. tighten bolts 2. replace compressor 3. rebuild compressor 4. check compressor RPMs (see page 36) & slow motor down if needed, hydraulic plumbing of the compressor is incorrect (see page 24 - 25)
Excessive moisture in discharge	<ol style="list-style-type: none"> 1. excessive water in air tank 2. high humidity 	<ol style="list-style-type: none"> 1. drain tank, drain tank more frequently 2. move compressor to area with less humidity.
Hydraulic motor front seal leakage	<ol style="list-style-type: none"> 1. case drain clogged or unplugged 2. case drain not plumbed correctly 	<ol style="list-style-type: none"> 1. remove case drain plumbing and clean out debris/obstruction, replace seal 2. Plumb case drain according to the instructions (see pages 25), replace seal
Row cleaners do not react uniformly	1. check each row cleaner for drag	1. replace bushings/parts causing drag or check hardware tightness
Row cleaners do not raise when seed units are raised	<ol style="list-style-type: none"> 1. no power to dump valves 2. not enough up pressure in air cylinder 3. limit switch needs repositioned 	<ol style="list-style-type: none"> 1. check voltage to limit switch, dump valves 2. make sure a minimum 30psi in RU circuit 3. reposition the limit switch to trip immediately when seed units raised



OPTIONAL

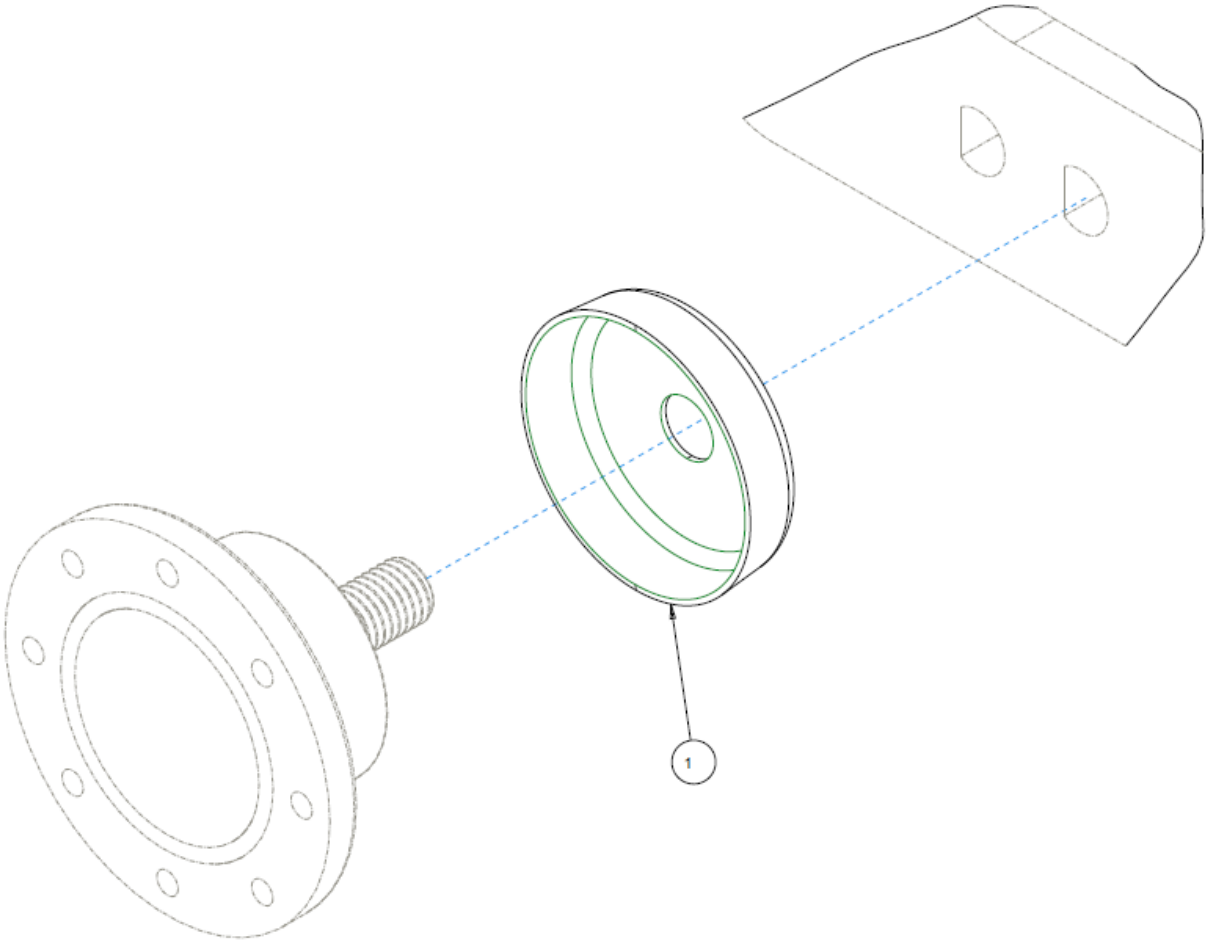

ITEM	PART NO.	DESCRIPTION	QTY
1	2965-550	BEARING SHIELD	1



A Tradition of Solutions since 1930

Yetter Farm Equipment Co

PO BOX 358 109 S. McDonough

Colchester, IL 62326-0358

Phone: 309-776-4111

Toll Free: 800-447-5777

Email: info@yetterco.com

For updated models and manuals visit the Yetter website:

www.yetterco.com

© Yetter Farm Equipment Co. All Rights Reserved

2565-979-REV-E • 11/2024