

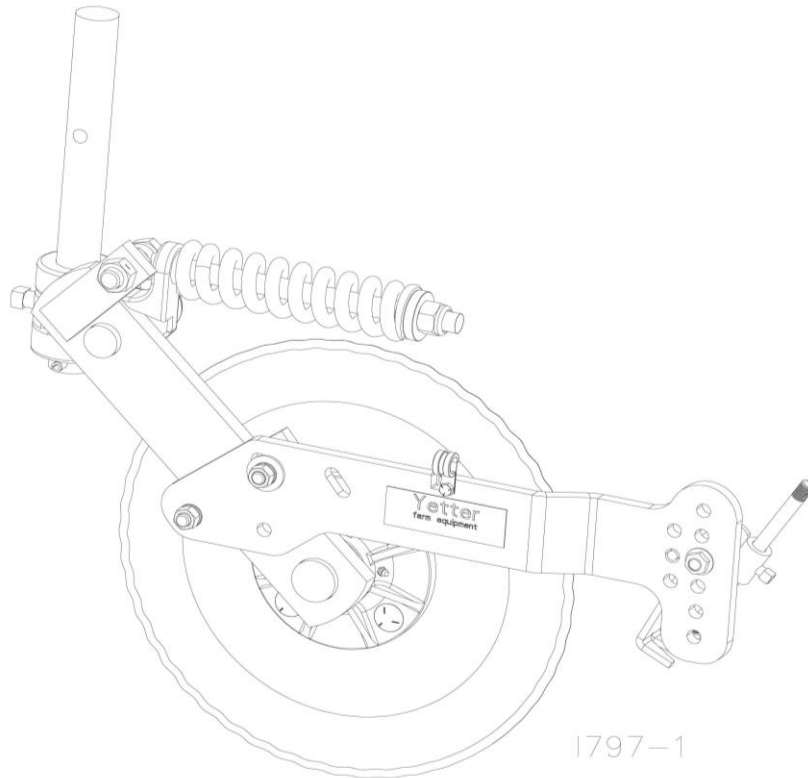

2910-137 INJECTION KIT LIQUID FERTILIZER

OPERATOR'S MANUAL
PART IDENTIFICATION
2565-760_REV_D • 02/2025



YETTER MANUFACTURING CO.
FOUNDED 1930

Colchester, IL 62326-0358
Toll free: 800/447-5777
309/776-3222 (Fax)
Website: www.yetterco.com
E-mail: info@yetterco.com

YETTER

FOREWORD

You've just joined an exclusive but rapidly growing club.
For our part, we want to welcome you to the group and thank you for buying a Yetter product.

We hope your new Yetter products will help you achieve both goals-increase your productivity and increase your efficiency so that you may generate more profit.

This operator's manual has been designed into four major sections: Foreword, Safety Precautions, Installation Instructions and Parts Breakdown.

This **SAFETY ALERT SYMBOL** indicates important safety messages in the manual. When you see this symbol, be alert to the possibility of **PERSONAL INJURY** and carefully read the message that follows.



DANGER: Indicates an imminently hazardous situation which, if not avoided "will" result in death or serious injury. This signal word is to be limited to the most extreme situations



WARNING: Indicates a potentially hazardous situation which, if not avoided, "could" result in death or serious injury.



CAUTION: Indicates a potentially hazardous situation, which if not avoided, "may" result in minor or moderate injury. It may also be used to alert against unsafe practices.



NOTICE: Indicates information considered important, but not hazard related (e.g., messages relating to property damage).

It is the responsibility of the user to read the operator's manual and comply with the safe and correct operating procedure and to lubricate and maintain the product according to the maintenance schedule in the operator's manual.

The user is responsible for inspecting his machine and for having parts repaired or replaced when continued use of the product would cause damage or excessive wear to the other parts.

It is the user's responsibility to deliver his machine to the Yetter dealer who sold him the product for service or replacement of defective parts, which are covered by the warranty policy.

If you are unable to understand or follow the instructions provided in this publication, consult your local Yetter dealer or contact:

YETTER MANUFACTURING CO.

309/776-4111

800/447-5777

309/776-3222 (FAX)

Website: www.yetterco.com

E-mail: info@yetterco.com

WARRANTY

Yetter Manufacturing warrants all products manufactured and sold by it against defects in material. This warranty being expressly limited to replacement at the factory of such parts or products as shall appear to be defective after inspection. This warranty does not obligate the Company to bear cost of labor in replacement of parts. It is the policy of the Company to make improvements without incurring obligations to add them to any unit already sold. No warranty is made or authorized to be made, other than herein set forth. This warranty is in effect for one year after purchase.

DEALER: _____

Yetter Manufacturing warrants its own products only and cannot be responsible for damages to equipment on which mounted.



SAFETY PRECAUTIONS



A brief description of signal words that may be used in this manual:

DANGER: Indicates an imminently hazardous situation which, if not avoided “will” result in death or serious injury. This signal word is to be limited to the most extreme situations.

WARNING: Indicates a potentially hazardous situation which, if not avoided, “could” result in death or serious injury.

CAUTION: Indicates a potentially hazardous situation, which if not avoided, “may” result in minor or moderate injury. It may also be used to alert against unsafe practices.

NOTICE: Indicates information considered important, but not hazard related (e.g., messages relating to property damage).

Consult your implement and tractor operator’s manual for correct and safe operating practices. Be aware of towed implement width and allow safe clearance.

Safety decals are placed on the implement to alert the operator and others to the risk of personal injury or unsafe operation during normal operations and servicing.

1. The safety decals must be kept clean and in good condition to ensure that they are legible.
2. Safety decals must be replaced if they are missing or illegible.
3. When components are replaced during repair or servicing, check that the new components include the necessary safety signs.
4. Replacement safety decals may be obtained from your local dealer.



WARNING

Read these instructions carefully to acquaint yourself with the Equipment. Working with unfamiliar equipment can lead to accidents.

Never park the equipment on a steep incline or leave the equipment running unattended.

Never clean, lubricate or adjust a machine that is in motion.

Always check that straps are secure.

Make sure latches are in pinned position when moving equipment.

Do not allow children to operate this equipment.

Do not allow riders on the equipment, trailer and/or pick-up.

Use speed and caution dictated by the terrain being traversed. Do not operate on any slope steep enough to cause tipping or loss of control.

Read and understand the operator’s manual and require all other persons who will operate the equipment to do the same.

If operating on public roadways, where legal, be certain all lighting is operating properly and observe all traffic laws.

Beware of increased stopping distances and control effort when operating with implements attached.

Be familiar with all controls and be prepared to stop equipment quickly in an emergency.

FAILURE TO HEED MAY RESULT IN PERSONAL INJURY OR DEATH.

LIQUID FERTILIZER APPLICATION RATE AND PRESSURE CHART

TABLES ARE BASED ON 30" NOZZLE SPACING

TIP #	LIQUID PRESSURE IN PSI	CAPACITY 1 NOZZLE IN GPM	GALLONS PER ACRE (USING WATER)					
			4 MPH H2O	5 MPH H2O	5.5 MPH H2O	6 MPH H2O	7 MPH H2O	8 MPH H2O
#00015	20	0.11	5.45	4.36	3.96	3.63	3.11	2.72
	25	0.12	5.94	4.75	4.32	3.96	3.39	2.97
	30	0.13	6.44	5.15	4.68	4.29	3.68	3.22
	40	0.15	7.43	5.94	5.40	4.95	4.24	3.71
	50	0.17	8.42	6.73	6.12	5.61	4.81	4.21
60	0.18	8.91	7.13	6.48	5.94	5.09	4.46	
#0002	20	0.14	6.93	5.54	5.04	4.62	3.96	3.47
	25	0.16	7.92	6.34	5.76	5.28	4.53	3.96
	30	0.17	8.42	6.73	6.12	5.61	4.81	4.21
	40	0.20	9.90	7.92	7.20	6.60	5.66	4.95
	50	0.23	11.39	9.11	8.28	7.59	6.51	5.69
60	0.25	12.38	9.90	9.00	8.25	7.07	6.19	
#0003	20	0.21	10.40	8.32	7.56	6.93	5.94	5.20
	25	0.24	11.88	9.50	8.64	7.92	6.79	5.94
	30	0.26	12.87	10.30	9.36	8.58	7.35	6.44
	40	0.30	14.85	11.88	10.80	9.90	8.49	7.43
	50	0.34	16.83	13.46	12.24	11.22	9.62	8.42
60	0.37	18.32	14.65	13.32	12.21	10.47	9.16	
#0004	20	0.28	13.86	11.09	10.08	9.24	7.92	6.93
	25	0.32	15.84	12.67	11.52	10.56	9.05	7.92
	30	0.35	17.33	13.86	12.60	11.55	9.90	8.66
	40	0.40	19.80	15.84	14.40	13.20	11.31	9.90
	50	0.45	22.28	17.82	16.20	14.85	12.73	11.14
60	0.49	24.26	19.40	17.64	16.17	13.86	12.13	
#0005	20	0.35	17.33	13.86	12.60	11.55	9.90	8.66
	25	0.40	19.80	15.84	14.40	13.20	11.31	9.90
	30	0.43	21.29	17.03	15.48	14.19	12.16	10.64
	40	0.50	24.75	19.80	18.00	16.50	14.14	12.38
	50	0.56	27.72	22.18	20.16	18.48	15.84	13.86
60	0.61	30.20	24.16	21.96	20.13	17.25	15.10	
#0006	20	0.42	20.79	16.63	15.12	13.86	11.88	10.40
	25	0.47	23.27	18.61	16.92	15.51	13.29	11.63
	30	0.52	25.74	20.59	18.72	17.16	14.71	12.87
	40	0.60	29.70	23.76	21.60	19.80	16.97	14.85
	50	0.67	33.17	26.53	24.12	22.11	18.95	16.58
60	0.74	36.63	29.30	26.64	24.42	20.93	18.32	
#0008	20	0.57	28.22	22.57	20.52	18.81	16.12	14.11
	25	0.63	31.19	24.95	22.68	20.79	17.82	15.59
	30	0.69	34.16	27.32	24.84	22.77	19.52	17.08
	40	0.80	39.60	31.68	28.80	26.40	22.63	19.80
	50	0.89	44.06	35.24	32.04	29.37	25.17	22.03
60	0.98	48.51	38.81	35.28	32.34	27.72	24.26	
#0010	20	0.71	35.15	28.12	25.56	23.43	20.08	17.57
	25	0.79	39.11	31.28	28.44	26.07	22.35	19.55
	30	0.87	43.07	34.45	31.32	28.71	24.61	21.53
	40	1.00	49.50	39.60	36.00	33.00	28.29	24.75
	50	1.12	55.44	44.35	40.32	36.96	31.68	27.72
60	1.23	60.89	48.71	44.28	40.59	34.79	30.44	
#0015	20	1.06	52.47	41.98	38.16	34.98	29.98	26.24
	25	1.19	58.91	47.12	42.84	39.27	33.66	29.45
	30	1.30	64.35	51.48	46.80	42.90	36.77	32.18
	40	1.50	74.25	59.40	54.00	49.50	42.43	37.13
	50	1.68	83.16	66.53	60.48	55.44	47.52	41.58
60	1.81	89.60	71.68	65.16	59.73	51.20	44.80	
ROW SPACING MULTIPLIER	10" X 3.3	15" X 2.0	18" X 1.66	20" X 1.5	36" X .83	38" X .79	40" X .75	

GPA = $\frac{5940 \times \text{GPM}}{\text{MPH} \times \text{W}}$ **H2O = WATER** **SOLUTION FACTOR**
 (Per Nozzle) **GPA = GALLON PER ACRE** 28% = H2O/1.13
 GPM = GALLON PER MINUTES 32% = H2O/1.15
 MPH = MILES PER HOUR
 W = WIDTH

This table is a reference only. Please calibrate your equipment to insure proper rate of application. The information contained in this issue is offered in good faith by Yetter Mfg. Co. to further the understanding of liquid fertilizer application.

However, the use of the information provided is beyond the control of Yetter Mfg. Co. and in no case shall Yetter Mfg. Co. or any seller of its products be responsible for any damages that may occur from the use of this information.

ASSEMBLY

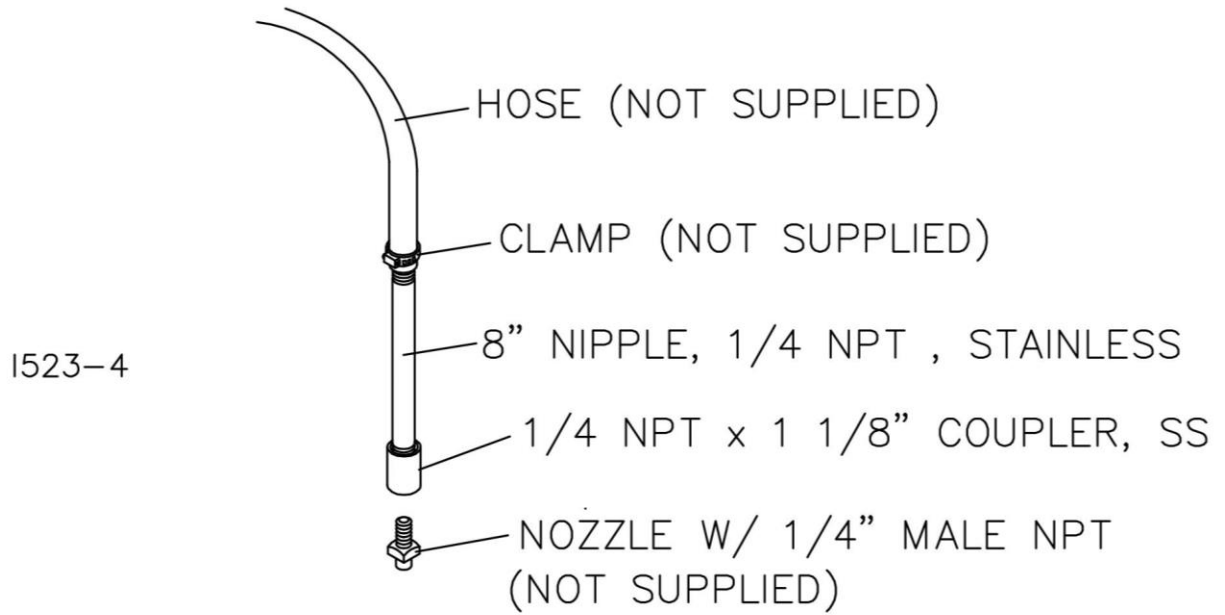

PARTS IDENTIFICATION

2910-137 – HIGH CLEARANCE INJECTOR KIT

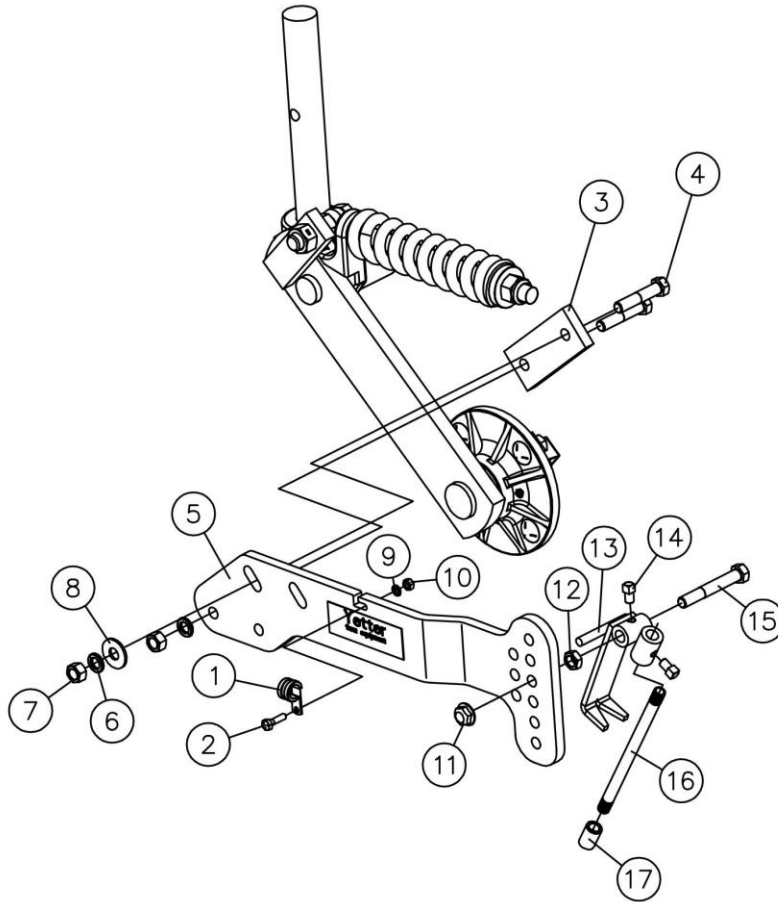

1797

ITEM	PART NO.	DESCRIPTION	QTY
1	2910-329	3/4" TUBE CLAMP	1
2	2502-110	1/4-20 X 1 CAP SCREW	1
3	2910-345	CLAMP PLATE	1
4	2502-296	1/2-13 X 2-1/2 CAP SCREW GRADE 5	2
5	2910-321	INJECTOR ARM	1
6	2525-352	1/2 LOCKWASHER	2
7	2520-352	1/2-13 HEX NUT	2
8	2526-351	1/2 FLAT WASHER	1
9	2525-151	1/4 LOCKWASHER	1
10	2520-151	1/4-20 HEX NUT	1
11	2520-366	1/2 FLANGED LOCK NUT SS	1
12	2520-367	1/2-13 JAM HEX NUT SS	1
13	2910-213	INJECTOR HOLDER	1
14	2503-256	3/8-16 X 1/2 SET SCREW SS	2
15	2502-321	1/2-13 X 3-1/2 CAP SCREW GRADE 5 SS	1
16	2515-318	8" NIPPLE 1/4 NPT SS	1
17	2515-312	1/4 NPT COUPLER SS	1

NOTES:

Our name Is getting known

Just a few years ago, Yetter products were sold primarily to the Midwest only. Then we embarked on a program of expansion and moved into the East, the South, the West and now north into Canada. We're even getting orders from as far away as Australia and Africa.

So, when you buy Yetter products . . .you're buying a name that's recognized. A name that's known and respected. A name that's become a part of American agriculture and has become synonymous with quality and satisfaction in the field of conservation tillage.

Thank you.

YETTER MANUFACTURING CO.
Colchester, IL 62326-0358 • 309/776-4111
Toll Free 800/447-5777
Fax 309/776-3222
Website: WWW.YETTERCO.COM
E-MAIL: INFO@YETTERCO.COM

2565-760_REV_D • 02/2025