

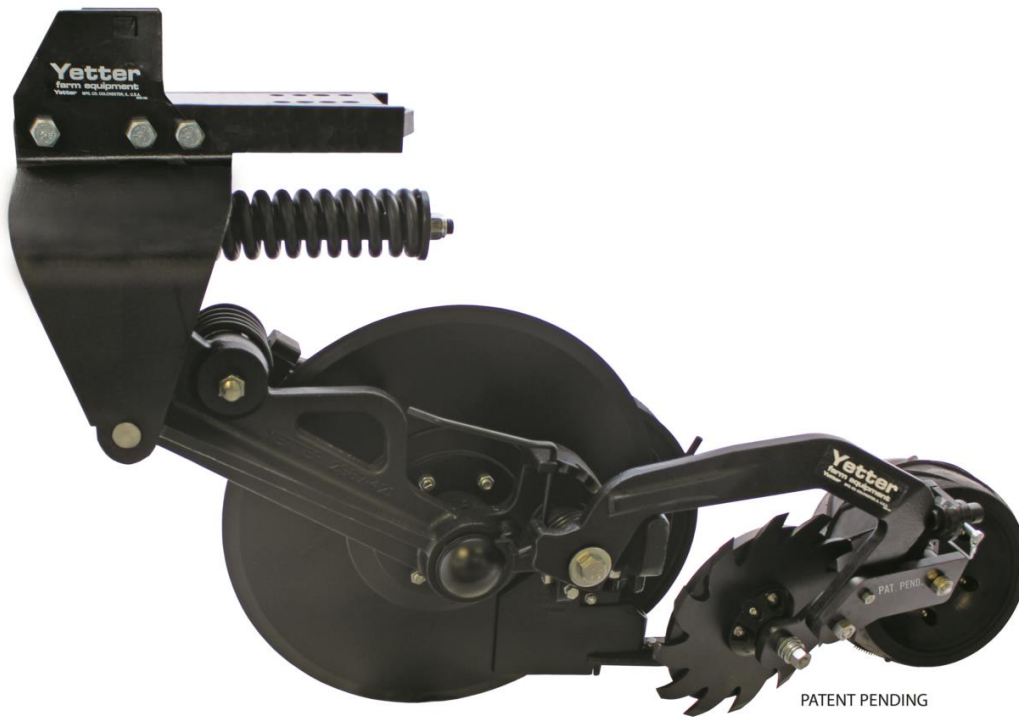

## 10000 SERIES MAGNUM™ FERTILIZER COULTER

2565-957\_Rev\_M 08/2024



**YETTER MANUFACTURING CO.**

*Founded 1930*

Colchester, IL 62326-0358

Toll free: 800-447-5777

Fax: 309-776-3222

Website: [www.yetterco.com](http://www.yetterco.com)

Email: [info@yetterco.com](mailto:info@yetterco.com)

# YETTER

## FOREWORD

You've just joined an exclusive but rapidly growing club.  
For our part, we want to welcome you to the group and thank you for buying a Yetter product.

We hope your new Yetter products will help you achieve both goals-increase your productivity and increase your efficiency so that you may generate more profit.

This operator's manual has been designed into four major sections: Foreword, Safety Precautions, Installation Instructions and Parts Breakdown.

This **SAFETY ALERT SYMBOL** indicates important safety messages in the manual. When you see this symbol, be alert to the possibility of **PERSONAL INJURY** and carefully read the message that follows.



**DANGER:** Indicates an imminently hazardous situation which, if not avoided "will" result in death or serious injury. This signal word is to be limited to the most extreme situations



**WARNING:** Indicates a potentially hazardous situation which, if not avoided, "could" result in death or serious injury.



**CAUTION:** Indicates a potentially hazardous situation, which if not avoided, "may" result in minor or moderate injury. It may also be used to alert against unsafe practices.



**NOTICE:** Indicates information considered important, but not hazard related (e.g., messages relating to property damage).

It is the responsibility of the user to read the operator's manual and comply with the safe and correct operating procedure and to lubricate and maintain the product according to the maintenance schedule in the operator's manual.

The user is responsible for inspecting his machine and for having parts repaired or replaced when continued use of the product would cause damage or excessive wear to the other parts.

It is the user's responsibility to deliver his machine to the Yetter dealer who sold him the product for service or replacement of defective parts, which are covered by the warranty policy.

If you are unable to understand or follow the instructions provided in this publication, consult your local Yetter dealer or contact:

### YETTER MANUFACTURING CO.

309/776-4111

800/447-5777

309/776-3222 (FAX)

Website: [www.yetterco.com](http://www.yetterco.com)

E-mail: [info@yetterco.com](mailto:info@yetterco.com)

## WARRANTY

Yetter Manufacturing warrants all products manufactured and sold by it against defects in material. This warranty being expressly limited to replacement at the factory of such parts or products as shall appear to be defective after inspection. This warranty does not obligate the Company to bear cost of labor in replacement of parts. It is the policy of the Company to make improvements without incurring obligations to add them to any unit already sold. No warranty is made or authorized to be made, other than herein set forth. This warranty is in effect for one year after purchase.

DEALER: \_\_\_\_\_

Yetter Manufacturing warrants its own products only and cannot be responsible for damages to equipment on which mounted.



## SAFETY PRECAUTIONS



A brief description of signal words that may be used in this manual:

**DANGER:** Indicates an imminently hazardous situation which, if not avoided “will” result in death or serious injury. This signal word is to be limited to the most extreme situations.

**WARNING:** Indicates a potentially hazardous situation which, if not avoided, “could” result in death or serious injury.

**CAUTION:** Indicates a potentially hazardous situation, which if not avoided, “may” result in minor or moderate injury. It may also be used to alert against unsafe practices.

**NOTICE:** Indicates information considered important, but not hazard related (e.g., messages relating to property damage).

Consult your implement and tractor operator’s manual for correct and safe operating practices. Be aware of towed implement width and allow safe clearance.

Safety decals are placed on the implement to alert the operator and others to the risk of personal injury or unsafe operation during normal operations and servicing.

1. The safety decals must be kept clean and in good condition to ensure that they are legible.
2. Safety decals must be replaced if they are missing or illegible.
3. When components are replaced during repair or servicing, check that the new components include the necessary safety signs.
4. Replacement safety decals may be obtained from your local dealer.



### WARNING

Read these instructions carefully to acquaint yourself with the Equipment. Working with unfamiliar equipment can lead to accidents.

Never park the equipment on a steep incline or leave the equipment running unattended.

Never clean, lubricate or adjust a machine that is in motion.

Always check that straps are secure.

Make sure latches are in pinned position when moving equipment.

Do not allow children to operate this equipment.

Do not allow riders on the equipment, trailer and/or pick-up.

Use speed and caution dictated by the terrain being traversed. Do not operate on any slope steep enough to cause tipping or loss of control.

Read and understand the operator’s manual and require all other persons who will operate the equipment to do the same.

If operating on public roadways, where legal, be certain all lighting is operating properly and observe all traffic laws.

Beware of increased stopping distances and control effort when operating with implements attached.

Be familiar with all controls and be prepared to stop equipment quickly in an emergency.

**FAILURE TO HEED MAY RESULT IN PERSONAL INJURY OR DEATH.**

# TABLE OF CONTENTS

Foreword .....	2
Safety.....	2-3
Torque .....	5
General Information.....	6-7
Assembly Instructions .....	8-9
Operation.....	10-12
Troubleshooting .....	13
Maintenance .....	14-18
Part Identification .....	19-51



**CAUTION:** The 10000 Series Magnum™ coulters are very heavy. Pay extra attention to lifting techniques when handling or maneuvering the coulter during assembly. Failure to do so may lead to personal injury.

# BOLT TORQUE

Before operating the 10000 Series Magnum™ for the first time, check to be sure that all hardware is tight. Check all hardware again after approximately 50 hours of operation and at the beginning of each planting season.

All hardware used on the 10000 Series Magnum™ is Grade 5 unless otherwise specified. Grade 5 cap screws are marked with three radial lines on the head. If hardware must be replaced, be sure to replace it with hardware of equal size, strength and thread type. Refer to the torque table below when tightening hardware.







**NOTICE:** Over tightening hardware can cause as much damage as when under tightening. Tightening hardware beyond the recommended range can reduce its shock load capacity.

The chart below is a guide for proper torque. Use it unless a specified torque is called out elsewhere in the manual.

Torque is the force you apply to the wrench handle or the cheater bar, times the length of the handle or bar.

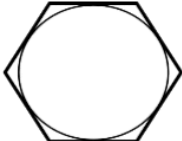
Use a torque wrench whenever possible.

The following table shows torque in ft. lbs. for coarse thread hardware.

Bolt Diameter and Threads per Inch	 Grade 2	 Grade 5	 A-325	 Grade 8
1/4	6	10		14
5/16	12	20		30
3/8 – 16	25	35		50
7/16 – 14	35	55		80
1/2 – 13	55	85		125
9/16 – 12	75	125		175
5/8 – 11	105	170		235
3/4-10	185	305		425
7/8 – 9	170	445		690
1-8	260	670		1030
1 1/8 – 7	365	900		1460
1 1/4 - 7	515	1275		2060
1 3/8 – 6	675	1675		2700
1 1/2 - 6	900	2150		3500
1 3/4 – 5	1410	3500		5600

# GENERAL INFORMATION

## 10000 Series Magnum™ Fertilizer Coulter

### STANDARD FEATURES FOR ALL MODELS

- High application speeds with minimal soil disturbance for fall, pre-plant, and side-dressing applications
- Tube kits for applying liquid, dry, or anhydrous
- All cast design
- Spring loaded knife with carbide tip for extended wear
- 22.6" blade set at 4° angle.
- Fits 4x4, 4x6, 5x7, 6x4, and 7x7 toolbar sizes
- Sharktooth® Wheel Closer standard

Model No.	Description	Est. Wt.
10000-001A-LH	LH MAGNUM, w/ Walking Tandem*, fits toolbars 4,5,6,7 wide Unv. Mt.	380 lbs
10000-001A-RH	RH MAGNUM, w/ Walking Tandem*, fits toolbars 4,5,6,7 wide-Unv. Mt.	380 lbs
10000-002A-LH	LH MAGNUM, w/ Walking Tandem*, fits toolbars 4" wide, Short Mt.	375 lbs
10000-002A-RH	RH MAGNUM, w/ Walking Tandem*, fits toolbars 4" wide, Short Mt.	375 lbs
10000-003A-LH	LH MAGNUM, w/o Walking Tandem*, fits toolbars 4,5,6,7 wide Unv. Mt.	355 lbs
10000-003A-RH	RH MAGNUM, w/o Walking Tandem*, fits toolbars 4,5,6,7 wide Unv. Mt.	355 lbs
10000-004A-LH	LH MAGNUM, w/o Walking Tandem*, fits toolbars 4" wide Short Mt.	345 lbs
10000-004A-RH	RH MAGNUM, w/o Walking Tandem*, fits toolbars 4" wide Short Mt.	345 lbs

### Section B:

Model No.	Description	Est. Wt.
2987-040-L	LH NH3 (3/8")Tube Kit	.395 lbs
2987-040-R	RH NH3 (3/8") Tube Kit	.395 lbs
2987-041-L	LH NH3 w/ Liquid (3/8" Dual) Tube Kit	.697 lbs
2987-041-R	RH NH3 w/ Liquid (3/8" Dual) Tube Kit	.697 lbs
2987-042-L	LH NH3 w/ Vapor (3/8" & 3/4") Tube Kit	.954 lbs
2987-042-R	RH NH3 w/ Vapor (3/8" & 3/4") Tube Kit	.954 lbs
2987-043-L	LH NH3 w/ Liquid & Vapor (3/8" Dual & 3/4" Single) Tube Kit	1.044 lbs
2987-043-R	RH NH3 w/ Liquid & Vapor (3/8" Dual & 3/4" Single) Tube Kit	1.044 lbs
2987-044-L	LH Vapor Only (3/4" )Tube Kit	.455 lbs
2987-044-R	RH Vapor Only (3/4") Tube Kit	.455 lbs
2987-046	Liquid (1/2" Single) Tube Kit	.425 lbs
2987-047	Liquid (1/2" Dual) Tube Kit	.850 lbs
2987-050	Dry (1-1/2")Tube Kit	1.159 lbs
2987-051	Dry w/ NH3 (1-1/2" & 3/8") Tube Kit	1.404 lbs
2987-052	Dry w/ NH3 & Vapor (1-1/2" & 3/8" & 3/4") Tube Kit	1.987 lbs
2987-053	Dry (1-1/2") Tube Kit	2.55 lbs
10000-050-LH	LH 10000 Magnum™ Dry Tube Assembly kit	1.5 lbs
10000-050-RH	RH 10000 Magnum™ Dry Tube Assembly Kit	1.5 lbs

### Section C:

Model No.	Description	Est Wt.
10000-011	4" Tall Toolbar Mount Hardware Kit	4 lbs
10000-012	5" Tall Toolbar Mount Hardware Kit	4.1 lbs
10000-013	6" Tall Toolbar Mount Hardware Kit	4.3 lbs
10000-014	7" Tall Toolbar Mount Hardware Kit	4.5 lbs

### Optional Equipment:

10000-020-LH	LH Walking Tandem* Wheel Conversion Kit	28.5 lbs
10000-020-RH	RH Walking Tandem* Wheel Conversion Kit	28.5 lbs
^^10000-080-LH	LH Residue Manager Mount bracket for 10000 Series Magnum	20 lbs
^^10000-080-RH	RH Residue Manager Mount bracket for 10000 Series Magnum	20 lbs
10000-099	2" Drop Down Kit (Wheel tracks for Magnum)	17 lbs

# GENERAL INFORMATION

## 10000 Magnum™ Fertilizer Coulter

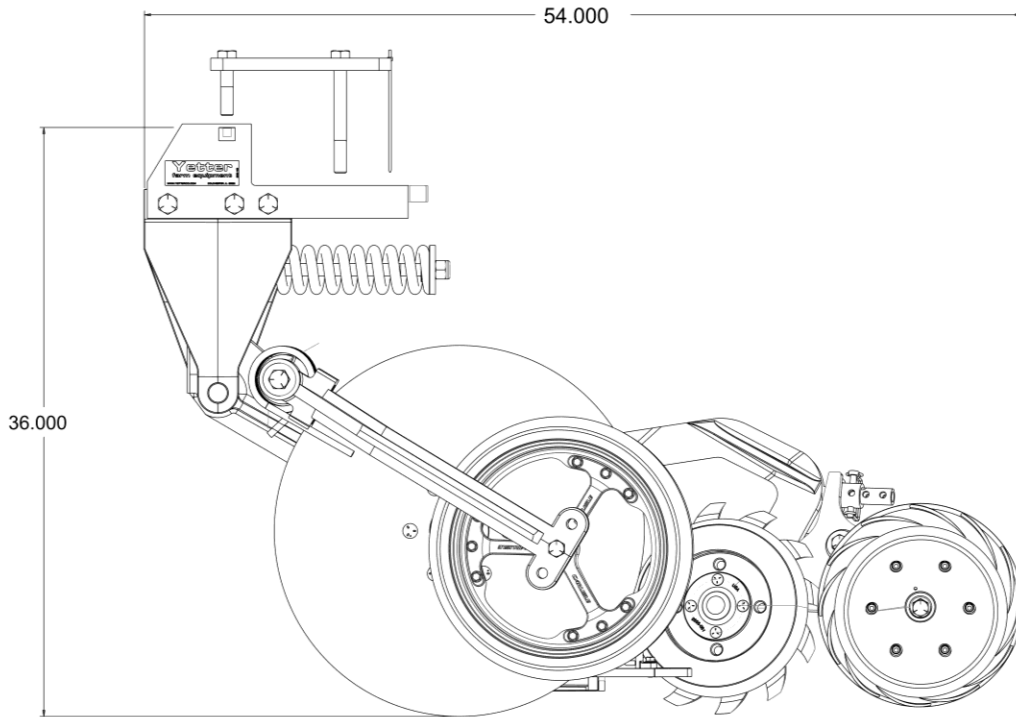
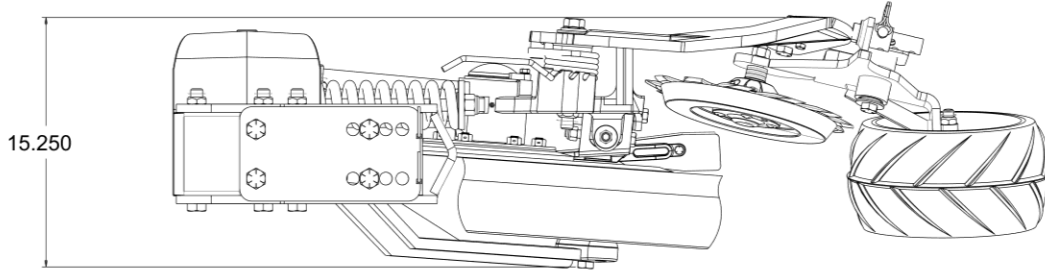



# ASSEMBLY INSTRUCTIONS



**WARNING:** Never work under the toolbar while in a raised position without using safety lockups.



**WARNING:** Use extreme caution, the blade is sharp and may cause bodily injury. The coulter can be mounted to the toolbar using different techniques. One way is to mount the main arm assembly to the toolbar and then attach the components one at a time. Another way is to completely assemble the coulter before attaching to the toolbar frame.



**CAUTION:** 10000 Magnum™ Fertilizer Coulter and its components are very heavy. Extra attention to lifting techniques while handling and or maneuvering the coulter during assembly is very important. **Failure to do so may lead to personal injury or death.**

**STEP 1:** Mark the toolbar frame as to the location that each coulter is to be mounted.

Install an equal quantity of right hand and left hand coulters to each section of the toolbar. Example: A 30' – 3 section toolbar with 12 coulters (6R & 6L) will need to install 2R and 2L coulters on each section of the toolbar. If any questions concerning assembly of coulters, then please contact Yetter Farm Equipment for recommendations at 800-447-5777.

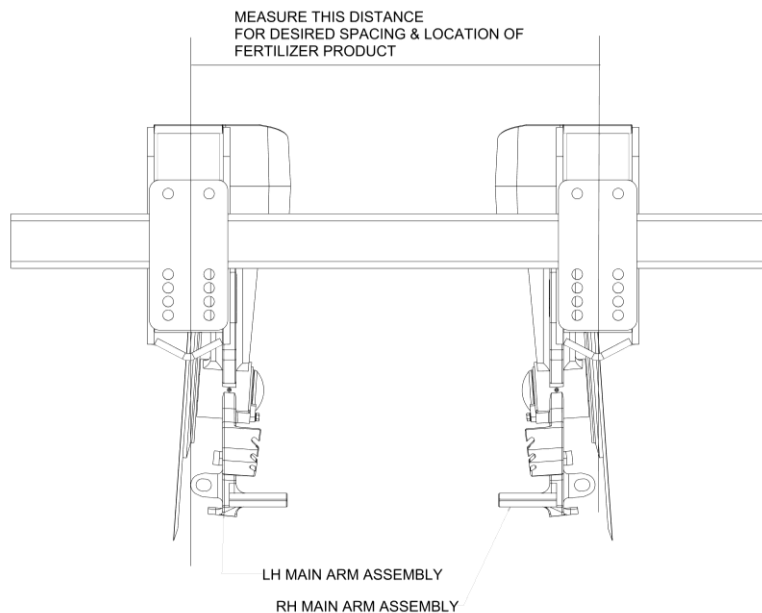

**NOTICE:** The coulter blade is in line with the center of the mount bracket. Measure from left edge to left edge or from right edge to right edge to ensure the coulters are mounted at the desired spacing.



# ASSEMBLY INSTRUCTIONS

**STEP 2:** Attach the 10000 Series Magnum™ to the toolbar using the appropriate clamp and hardware.

## HARDWARE KITS PART IDENTIFICATION

10000-011 4" TALL TOOLBAR MOUNT KIT

ITEM	PART NO.	DESCRIPTION	QTY
1	2502-401	3/4-10 X 3-1/2 HHCS GRADE 5, ZP	2
2	2502-509	3/4-10 X 7 HHCS GRADE 5, ZP	2
3	2520-506	3/4-10 HEX NUT, GR 8, ZP	2
4	2525-501	3/4 MED LOCKWASHER ZP	4

10000-012 5" TALL TOOLBAR MOUNT KIT

ITEM	PART NO.	DESCRIPTION	QTY
1	2502-404	3/4-10 X 4 HHCS GRADE 5, ZP	2
2	2502-408	3/4-10 X 7-1/2 HHCS GRADE 5, ZP	2
3	2520-506	3/4-10 HEX NUT, GR 8, ZP	2
4	2525-501	3/4 MED LOCKWASHER ZP	4

10000-013 6" TALL TOOLBAR MOUNT KIT

ITEM	PART NO.	DESCRIPTION	QTY
1	2502-507	3/4-10 X 5 HHCS GRADE 5, ZP	2
2	2502-514	3/4-10 X 9 HHCS GRADE 5, ZP	2
3	2520-506	3/4-10 HEX NUT, GR 8, ZP	2
4	2525-501	3/4 MED LOCKWASHER ZP	4

10000-014 7" TALL TOOLBAR MOUNT KIT (SHOWN)

ITEM	PART NO.	DESCRIPTION	QTY
1	2502-510	3/4-10 X 6 HHCS GRADE 5, ZP	2
2	2502-516	3/4-10 X 9-1/2 HHCS GRADE 5, ZP	2
3	2520-506	3/4-10 HEX NUT, GR 8, ZP	2
4	2525-501	3/4 MED LOCKWASHER ZP	4

ISO-10000-011

# OPERATION INSTRUCTIONS

## TOOLBAR FRAME HEIGHT ADJUSTMENT

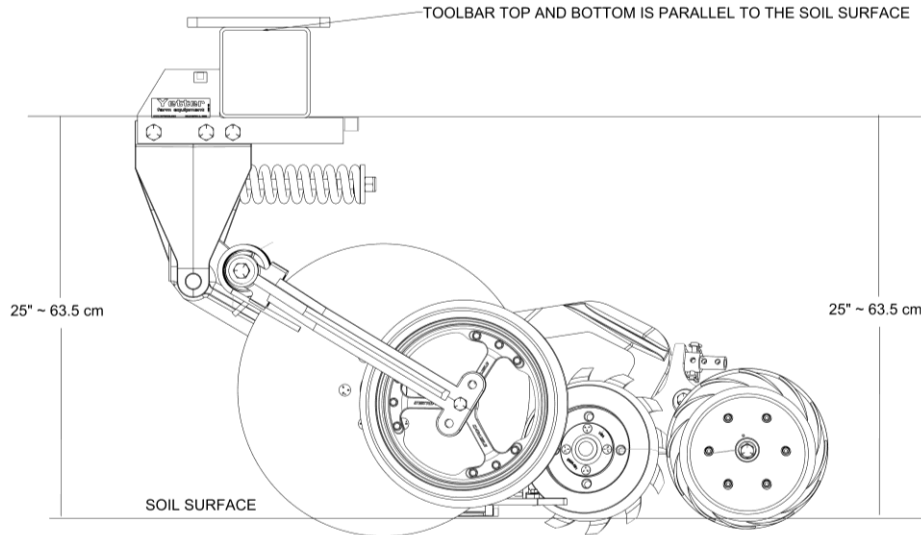

FIGURE A (CORRECT)

Adjusting Opener Depth:  
-Raise toolbar frame for shallow application  
-Lower toolbar frame for deeper application

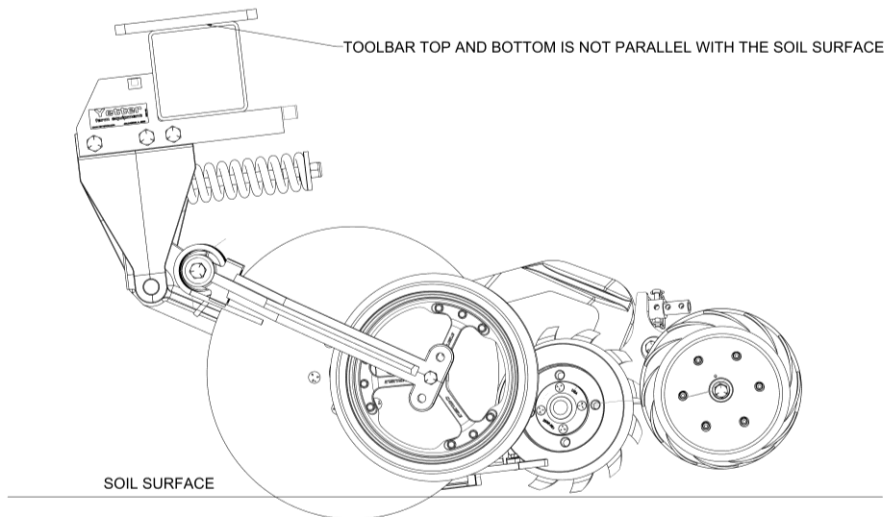

FIGURE B (INCORRECT)

**Figure A:** The toolbar height is set to 25" above the soil surface. To ensure that frame heights are correct, it is important measurements are taken before use.

**Figure B:** The hitch is set too low while the toolbar is not parallel with the soil surface.



**NOTICE:** The illustrations are intended to show that the settings are critical. **Tool frame levelness and height adjustment are very important settings for correct performance of the 10000 Magnum™ Coulters**

# OPERATION INSTRUCTIONS

## 10000 MAGNUM™ CLOSING WHEEL DOWNFORCE ADJUSTMENT

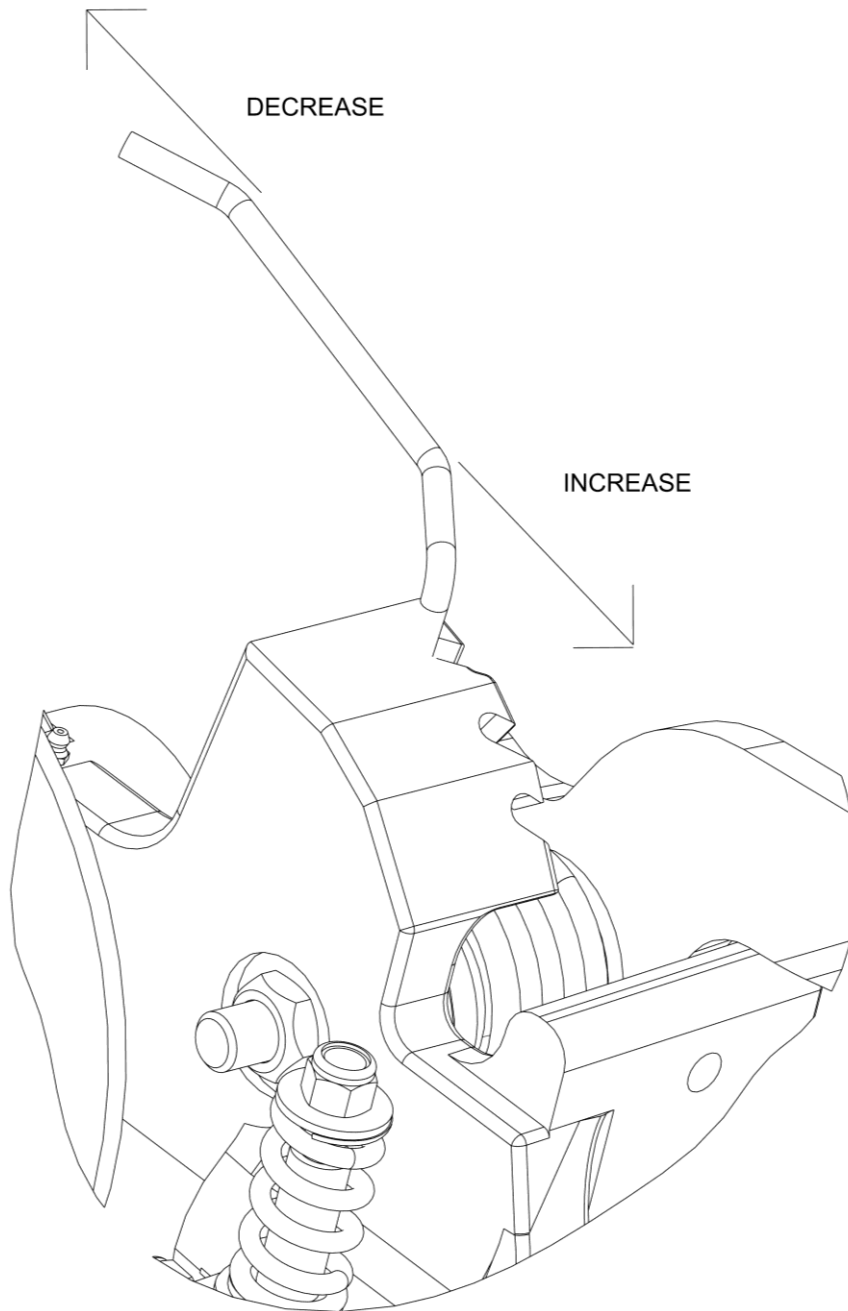

# OPERATION INSTRUCTIONS

## 10000 MAGNUM™ WHEEL SEALER DEPTH ADJUSTMENT

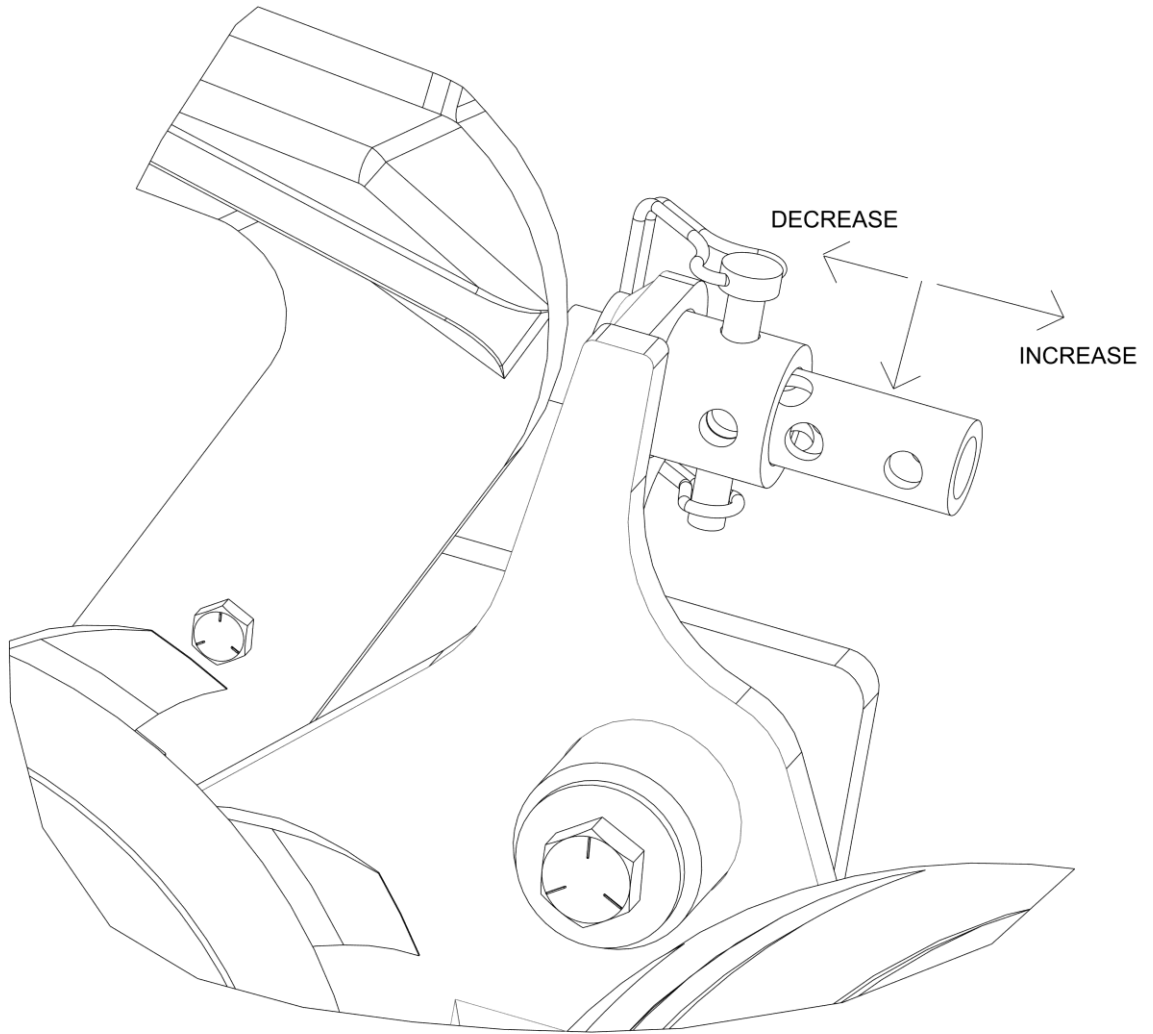

# OPERATION INSTRUCTIONS

## Troubleshooting the 10000 Series Magnum™ Coultter

Symptom	Problem	Solution
Mud builds up on press wheels and wheels stop turning	Too much down pressure	Remove spring pressure from press wheels
	Field is too wet	Wait until field dries before running
Poor opener penetration	Hard ground conditions	Add weights to toolbar frame
	Residue laying in bunches	Spread residue evenly across the field
	Excessive residue	Adjust toolbar for deeper operation
	Dull disk openers	Sharpen or replace opener disks
	Disk opener worn too small	Replace disk opener
Furrow not closing	Field is too wet or overly hard ground conditions	Adjust closing wheel spring pressure
Soil freezes to blade		Raise toolbar when stopping to prevent anhydrous ammonia from contacting and freezing soil to blade
Residue buildup in front of openers	Residue wedged between scraper and disk opener	Verify adjustment bolt is properly adjusted to hold scraper against blade
Uneven depth	Residue laying in bunches	Spread residue evenly across field
	In adequate down pressure	Increase down pressure or install weights

# MAINTENANCE

## Practice Safety

Understand and practice safe service procedures before doing work. Follow ALL the operating, maintenance, and safety information in the equipment operator's manual. Clear the area of bystanders, especially small children, when performing any maintenance or adjustments. Keep work area clean and dry. Use adequate lighting for the job. Use only tools, jacks, and hoists of sufficient capacity for the job.

Never lubricate, service, or adjust a machine while it is moving. Keep hands, feet, and clothing free from power-driven moving parts. Disengage all power and operate controls to relieve pressure. Lower equipment to the ground and stop the engine. Remove the key. Wait for all moving parts to stop before servicing, adjusting, repairing, or unplugging.

Securely support any machine elements with blocks or safety stands that must be raised for service work.

Keep all parts in good condition and properly installed. Fix damaged equipment immediately. Replace worn or broken parts. Remove any buildup of grease, oil, or debris from the equipment.

Make sure all guards are in place and properly secured when maintenance work is completed.

# MAINTENANCE

## Lubrication Intervals

Lubricate with grease at hourly interval indicated on symbol.

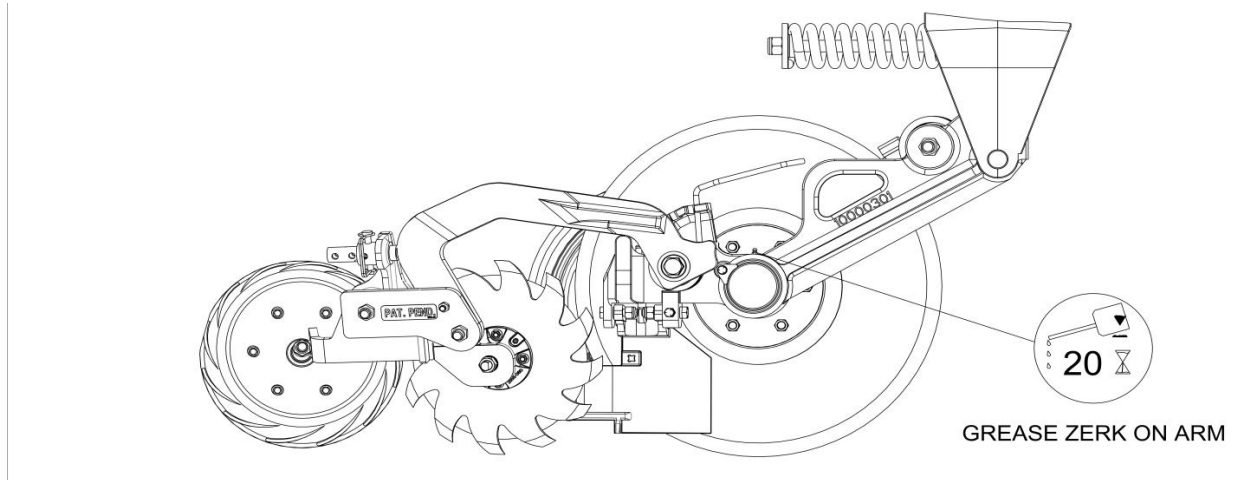

**The recommended service intervals are based on normal operating conditions. Severe or unusual conditions may require more frequent lubrication.**

**Perform each lubrication and service procedure at the beginning of each season. Clean grease fittings before using grease gun to avoid injecting dirt and grit into the bearing. Replace and lost or broken fittings immediately. If a fitting fails to take grease, remove and clean thoroughly, replace if necessary. Also check for failure of adjoining parts.**



# MAINTENANCE

## Lubrication



**CAUTION:** To help prevent serious injury or death to you or others, service machinery on a level surface. Lower machine to ground or sufficiently lock or block raised machine before servicing. If machine is connected to tractor, engage parking brake and place transmission in “PARK”, shut off engine and remove key. If machine is detached from tractor, block wheels and use jack stands to prevent movement.



**CAUTION:** Do not clean, lubricate, or adjust machine while in motion.

Use grease based on NLGI consistency number and the expected air temperature range during operation.

Use a **multi-purpose polyurea, water resistant, moderate speed, and NLGI grade #2** grease. Other greases may be used if they meet the **NLGI performance standard**.

Some types of grease thickener are not compatible with others. Consult your grease supplier before mixing different types of grease.

### Alternative Lubricants

Conditions in certain geographical areas may require special lubricants and lubrication practices which do not appear in the operator’s manual. If there are any questions, consult Yetter Manufacturing Co. to obtain the latest information and recommendations.

Part #	Description	Ounces of Grease
10000-111-LH 10000-111-RH	Main Arm, Magnum Assembly	18 oz

### Storing Lubricants

Your machine can operate at top efficiency only if clean lubricants are used.

Use clean containers to handle all lubricants.

**Store them in an area protected from dust, moisture, and other contaminants.**

## MAINTENANCE

### Storing the Equipment

Store the machine in an area away from human activity.

Store the machine in a RAISED position.

Install service locks on all wheel cylinders.

At the end of the season the machine should be thoroughly inspected and prepared for storage. Repair or replace any worn or damaged components to prevent down time at the beginning of the following season. Store machine under cover with all parts in operating condition.

- Clean machine thoroughly to remove all dirt, debris, and crop residue.
- Inspect machine for worn or broken parts. See your Yetter Farm Equipment dealer during the off-season so parts and service can be acquired when the machine is not needed in the field.
- Lubricate bearings as outlined in the lubrication section.
- Paint all parts which are chipped or worn to prevent rust.
- Store machine in a clean, dry location with the unit out of the sun.
- If the machine cannot be stored inside, cover with a waterproof tarpaulin and tie securely in place
- Do not allow children to play on or around the machine

# MAINTENANCE

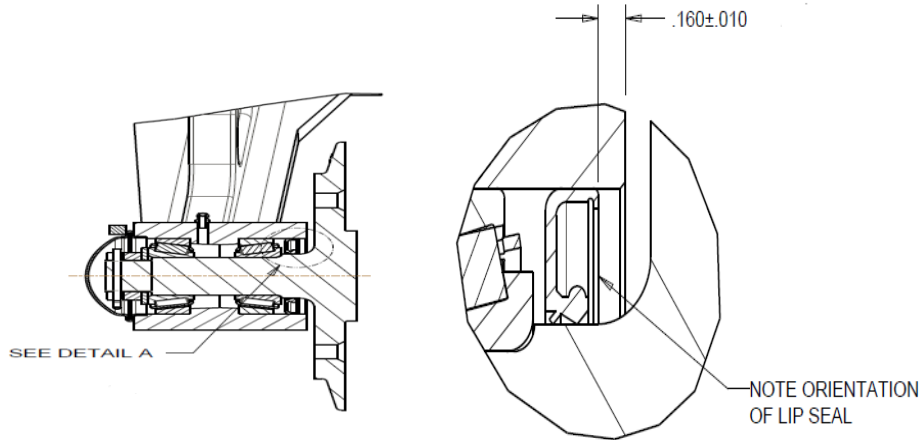

## BEARING ADJUSTMENT:

1. Raise the toolbar until the blade is clear of the ground. Place a safety stand under the toolbar. Remove the blade. Remove the hub cap, cotter pin, slotted nut, washer and spacer from the spindle shaft assembly.
2. Pull the coulter spindle shaft assembly from the hub. Remove bearing cones and seal.
3. Wash the old grease from the hub, bearing cups, coulter spindle shaft, seal and bearing cones. Inspect the condition of bearing cups, cones and seal. Replace if necessary.
4. Apply #2 multi-purpose **polyurea** grease on each bearing. Make sure the space around each roller is filled. Lubricate the bearing cups.
5. Position the bearing in the cup and install the seal. Lubricate the seal lips and proceed with re-assembly of the removed parts including the blade. Blade bolt torque is 90 - 96 ft/lbs.
6. While rotating the spindle, tighten/torque the slotted nut to 15-20 ft/lbs. to pre-load the bearings. Loosen the slotted nut ½ turn to release the pre-load.
7. While rotating the spindle, tighten the slotted nut until the next castellation opening on the nut is aligned with a hole in the spindle. Install the cotter pin and bend the ends of the pin around the nut.
8. Check the spindle rotation, if the spindle rotates freely then install hub cap, retainer, bolt and lock washer. If the spindle is difficult to turn and/or roughness is felt then replace the bearings and cups as required.

## KNIFE WEAR:

The lower portion of the scraper and tube are subject to wear during operation. The rate of wear will depend on a variety of factors and in abrasive hard soil conditions the wear will be more rapid.

NOTE: In certain areas, replacement knives should be kept in stock, replacing worn knives as needed.

**ADJUST KNIFE TO BLADE CONTACT** on each opener so the blade will turn by hand with slight resistance, but will not coast or freewheel. In loose soil the knife adjustment is critical. If adjustment is not maintained, soil or residue may wedge between knife and blade, resulting in the blade not turning. Because of blade run out, rotate the blade one full revolution after adjustment. Re-adjust knife as needed. Never strike the knife with a heavy object or damage may occur. To adjust, use shims or adjust knife mounting out.

**PART IDENTIFICATION**  
**10000-001B-LH (SHOWN) LEFT HAND & 10000-001B-RH RIGHT HAND MAGNUM**  
**W/ WALKING TANDEM CLOSING SYSTEM**  
**4,5,6,7 WIDE TOOLBAR UNIVERSAL MOUNT**

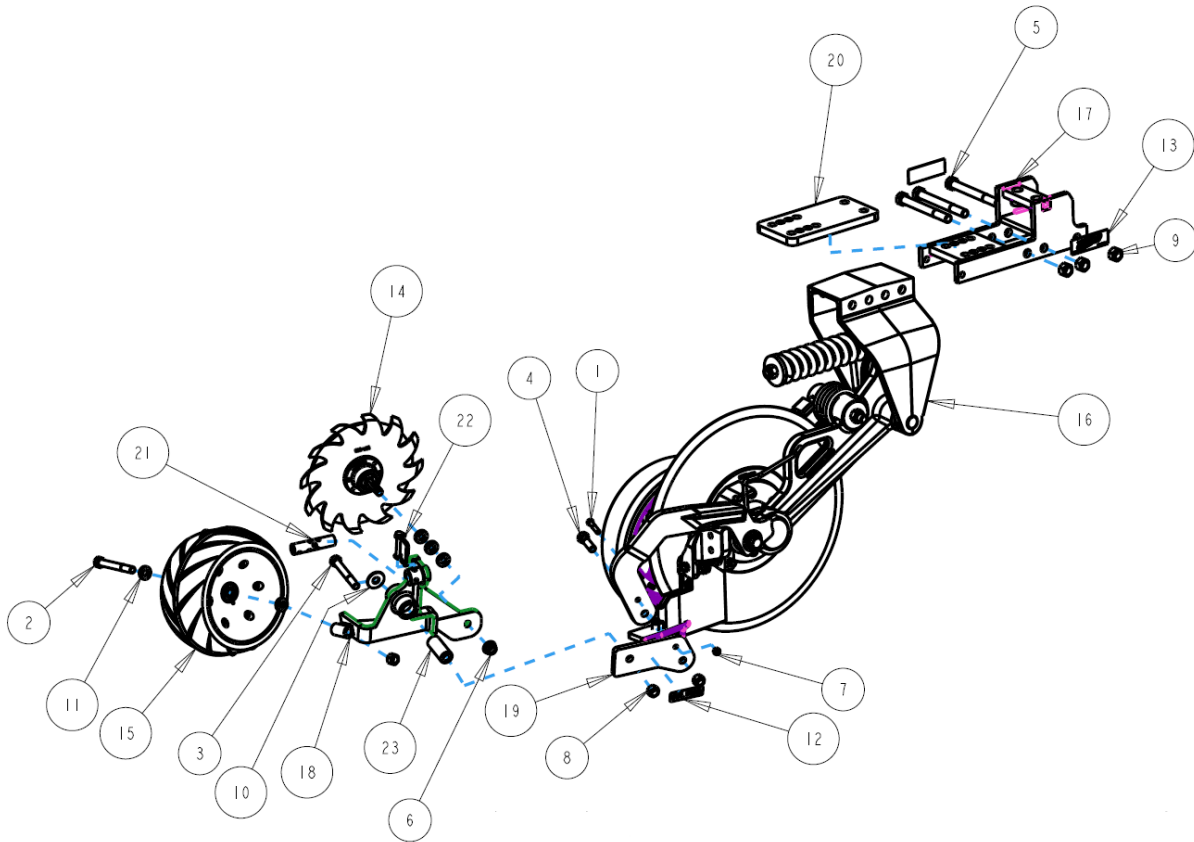

ITEM	PART NO.	DESCRIPTION	QTY
1	2502-245	3/8-16 X 1-3/4 HHCS GR. 5	1
2	2502-327	5/8-11 X 5 HHCS GR. 5	1
3	2502-334	5/8-11 X 4-1/2 HHCS GR. 5	1
4	2502-391	5/8-11 X 2 HHCS GR. 5	1
5	2502-509	3/4-10 X 7 HHCS GR. 5	3
6	2520-465	5/8-11 FLANGE NUT GR. 8	1
7	2520-601	3/8-16 TOP LOCK HEX NUT GR. C	1
8	2520-603	5/8-11 TOP LOCK HEX NUT GR. C	3
9	2520-604	3/4-10 TOP LOCK HEX NUT GR. C	3
10	2526-451	5/8 FLAT WASHER	1
11	2526-455	WASHER 21/32" ID. X 1-1/4" OD. X 1/4" THICK	5
12	2565-071	PATENT DECAL	1
13	2565-162	YETTER DECAL	2
14	2987-142-L	LH CAST CLOSER WHEEL ASSEMBLY	1
15	6200-363	6.5 X 12 PRESS WHEEL ASSEMBLY	1
	2570-069	40MM BEARING	1
16	10000-100-LH	LH BASE ASSEMBLY	1
17	10000-200	TOOLBAR MOUNT 4,5,6,7	1
18	10000-205-LH	LH TANDEM CLOSER PIVOT	1
	10000-332	SLEEVE 1.5" OD. X 1.25" ID. X 0.75" WIDTH	2
19	10000-308	TANDEM MOUNT PLATE	1
20	10000-310	CLAMP PLATE UNIVERSAL	1
21	10000-330	ADJUSTMENT TUBE	1
22	10000-334	3/8" WIRE PIN	1
23	10000-361	SEALER PIVOT BUSHING	1

## PART IDENTIFICATION

10000-002-LH (SHOWN) & 10000-002-RH  
MAGNUM w/ WALKING TANDEM  
4" WIDE TOOLBAR, SHORT MOUNT

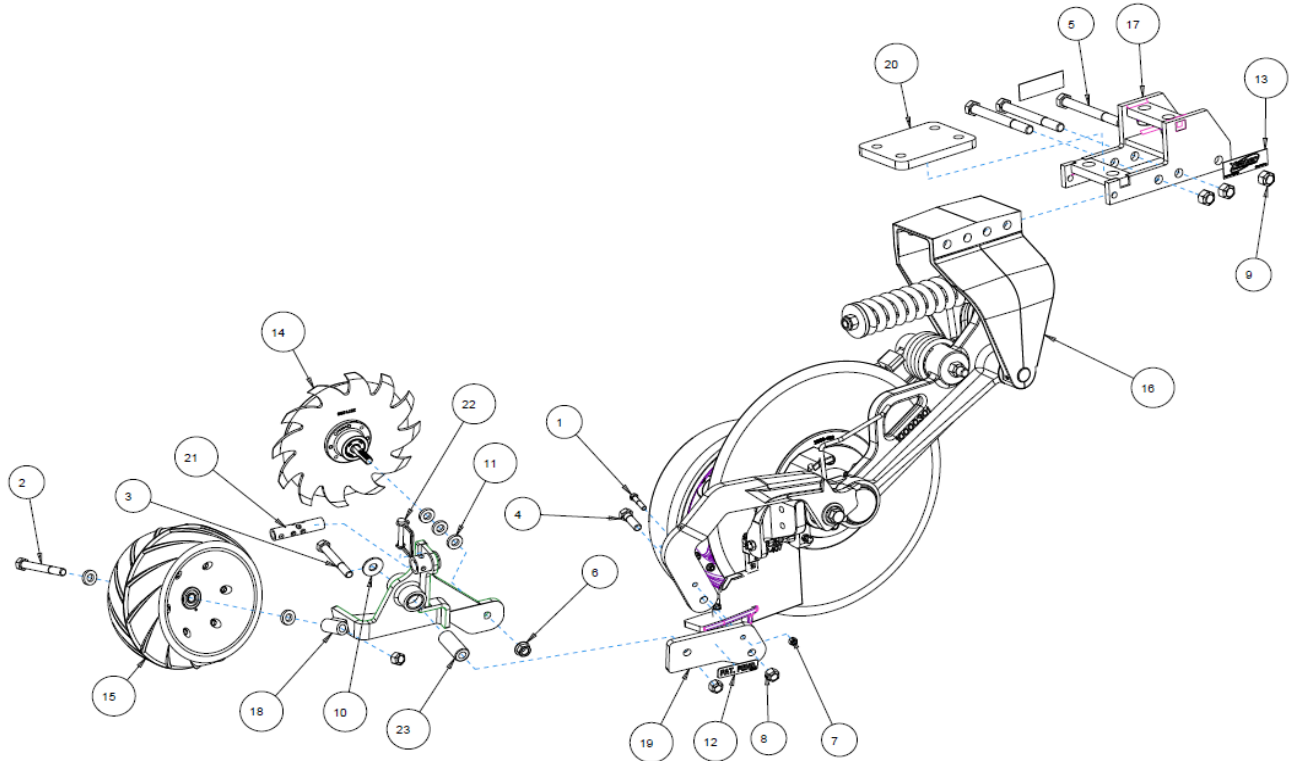

ITEM	PART NO.	DESCRIPTION	QTY.
1	2502-245	3/8-16 X 1-3/4 HHCS GR. 5	1
2	2502-327	5/8-11 X 5 HHCS GR. 5	1
3	2502-334	5/8-11 X 4-1/2 HHCS GR. 5	1
4	2502-391	5/8-11 X 2 HHCS GR. 5	1
5	2502-509	3/4-10 X 7 HHCS GR. 5	3
6	2520-465	5/8-11 FLANGE HEX NUT GR. 8	1
7	2520-601	3/8-16 TOP LOCK HEX NUT GR. C	1
8	2520-603	5/8-11 TOP LOCK HEX NUT GR. C	3
9	2520-604	3/4-10 TOP LOCK HEX NUT GR. C	3
10	2526-451	5/8 FLAT WASHER	1
11	2526-455	WASHER 21/32 ID. X 1-1/4 OD. X 1/4 THK	5
12	2565-071	PATENT DECAL	1
13	2565-162	YETTER DECAL	2
14	2987-142-L	LH CAST CLOSING WHEEL ASSEMBLY	1
15	6200-363	6.5 X 12 PRESS WHEEL ASSEMBLY	1
	2570-069	40MM BEARING	1
16	10000-100-LH	LH BASE ASSEMBLY	1
17	10000-201	4" MOUNT	1
18	10000-205-LH	LH TANDEM CLOSER PIVOT	1
	10000-332	SLEEVE 1.5" OD. X 1.25" ID. X 0.75" WIDTH	2
19	10000-308	TANDEM MOUNT PLATE	1
20	10000-311	CLAMP PLATE 4" TOOLBAR	1
21	10000-330	ADJUSTMENT TUBE	1
22	10000-334	3/8" WIRE PIN	1
23	10000-361	SEALER PIVOT BUSHING	1

## PART IDENTIFICATION

10000-003-LH (SHOWN) & 10000-003-RH  
MAGNUM w/o WALKING TANDEM. 4". 5". 6". 7" WIDE TOOLBARS

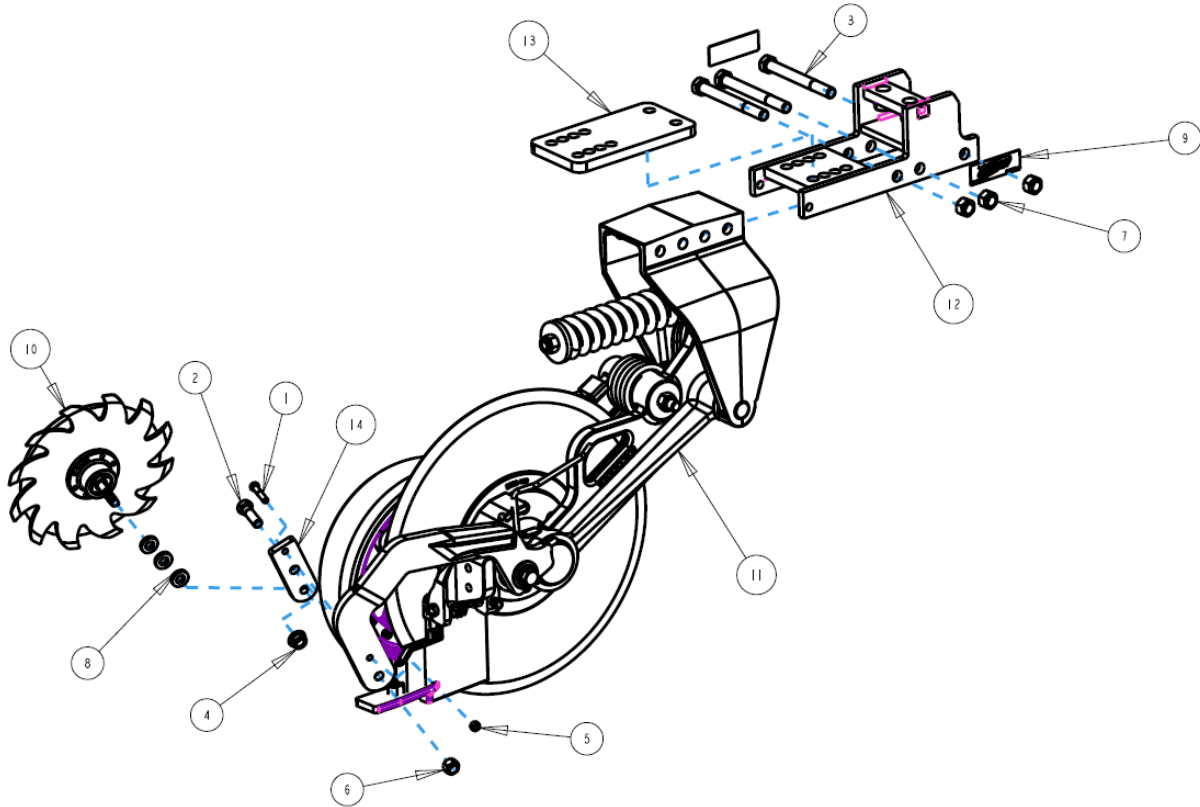

ITEM	PART NO.	DESCRIPTION	QTY
1	2502-245	3/8-16 X 1-3/4 HHCS GR. 5	1
2	2502-391	5/8-11 X 2 HHCS GR. 5	1
3	2502-509	3/4-10 X 7 HHCS GR. 5	3
4	2520-465	5/8-11 FLANGE HEX NUT GR. 8	1
5	2520-601	3/8-16 TOP LOCK HEX NUT GR. C	1
6	2520-603	5/8-11 TOP LOCK HEX NUT GR. C	1
7	2520-604	3/4-10 TOP LOCK HEX NUT GR. C	3
8	2526-455	WASHER 21/32 ID. X 1-1/4 OD. X 1/4 THK	3
9	2565-162	YETTER DECAL	2
10	2987-142-L	LH CAST CLOSING WHEEL ASSEMBLY	1
11	10000-100-LH	LH BASE ASSEMBLY	1
12	10000-200	TOOLBAR MOUNT 4,5,6,7	1
13	10000-310	CLAMP PLATE UNIVERSAL	1
14	10000-312	CLOSER MOUNT PLATE	1

**PART IDENTIFICATION**  
**10000-004-LH (SHOWN) & 10000-004-RH**  
**MAGNUM w/o WALKING TANDEM, 4" WIDE TOOLBARS, SHORT MOUNT**

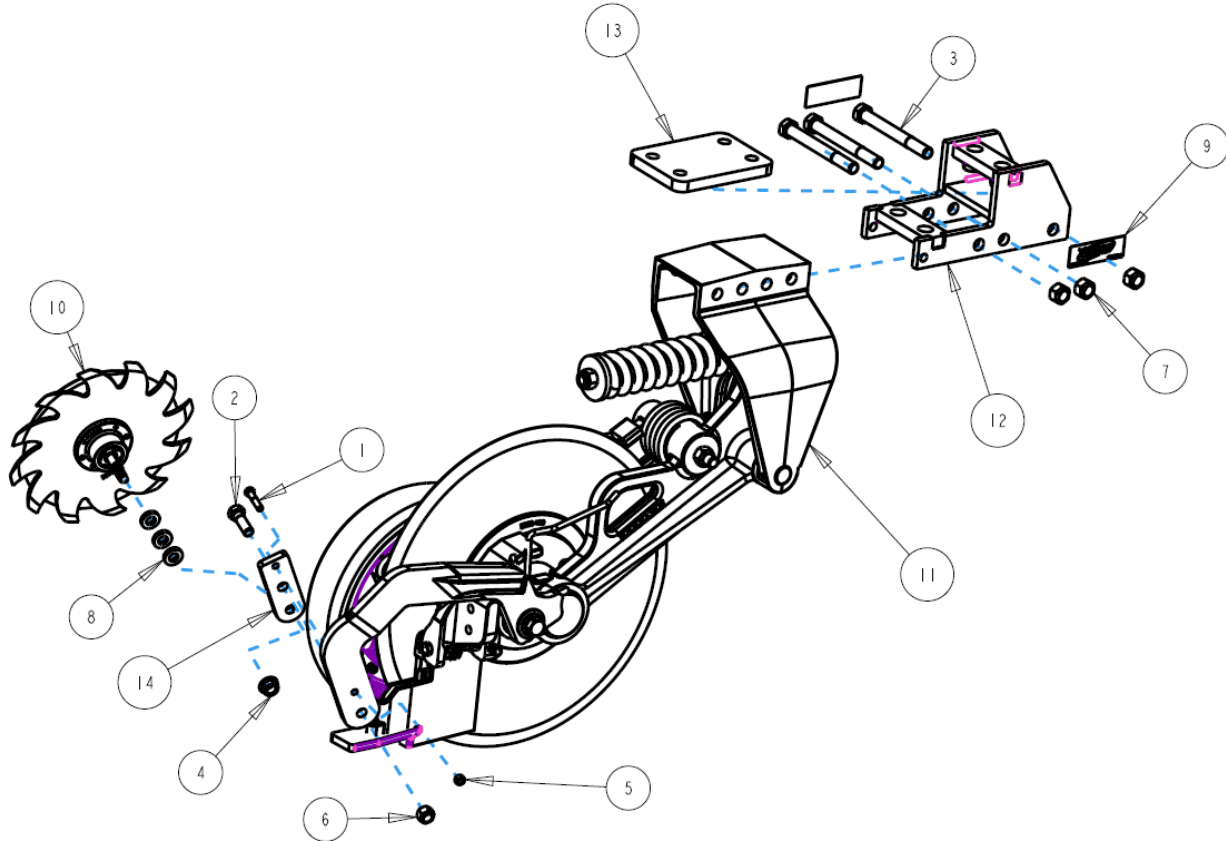

ITEM	PART NO.	DESCRIPTION	QTY
1	2502-245	3/8-16 X 1-3/4 HHCS GR. 5	1
2	2502-391	5/8-11 X 2 HHCS GR. 5	1
3	2502-509	3/4-10 X 7 HHCS GR. 5	3
4	2520-465	5/8-11 FLANGE HEX NUT GR. 8	1
5	2520-601	3/8-16 TOP LOCK HEX NUT GR. C	1
6	2520-603	5/8-11 TOP LOCK HEX NUT GR. C	1
7	2520-604	3/4-10 TOP LOCK HEX NUT GR. C	3
8	2526-455	WASHER 21/32 ID. X 1-1/4 OD. X 1/4 THK	3
9	2565-162	YETTER DECAL	2
10	2987-142-L	LH CAST CLOSING WHEEL ASSEMBLY	1
11	10000-100-LH	LH BASE ASSEMBLY	1
12	10000-201	TOOLBAR MOUNT 4 INCH	1
13	10000-311	CLAMP PLATE 4 INCH	1
14	10000-312	CLOSER MOUNT PLATE	1



PART IDENTIFICATION  
 10000-099  
 2" DROP DOWN KIT

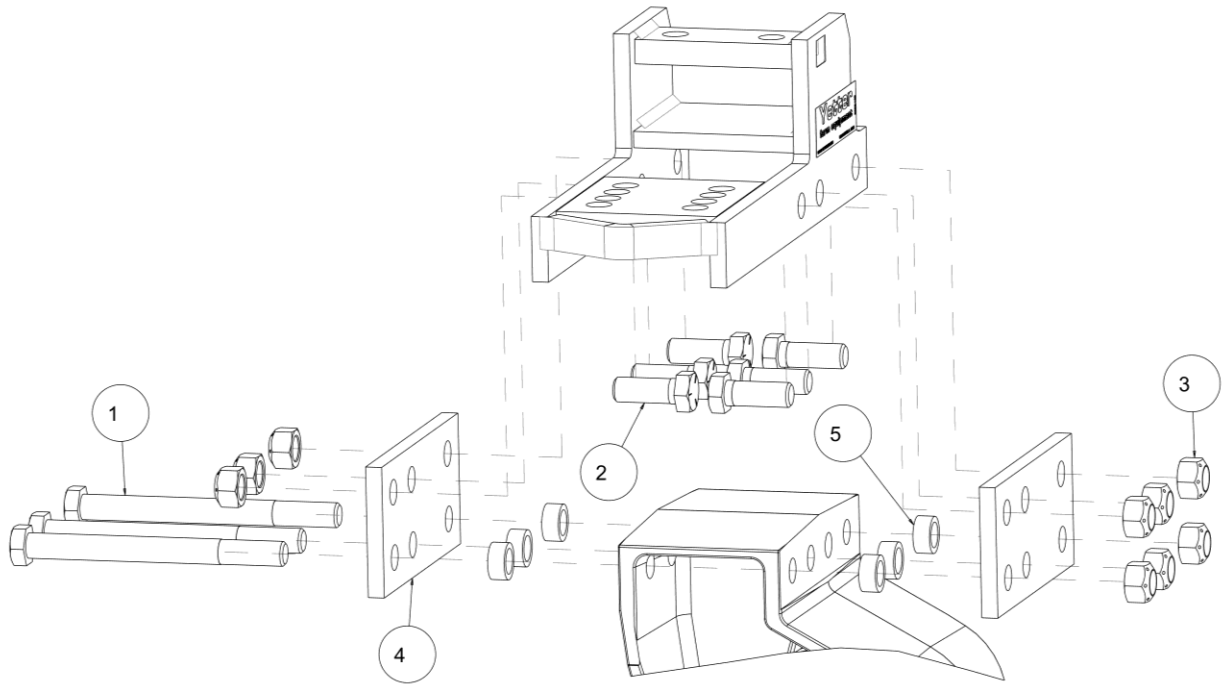

DROP DOWN KIT TO BE USED IN WHEEL TRACKS

ITEM	PART #	DESCRIPTION	QTY
1	2502-405	3/4-10 X 8 HHCS GR. 5 ZP	3
2	2502-503	3/4-10 X 2 HHCS GR.5 ZP	6
3	2520-604	3/4-10 HEX TOP LOCK, GR. C, ZP	9
4	10000-348	DROP-DOWN PLATE	2
5	10000-349	BUSHING	6

**PART IDENTIFICATION**  
**10000-100-LH (SHOWN) & 10000-1000-RH**  
**MAGNUM BASE ASSEMBLY**

ITEM	PART #	DESCRIPTION	QTY
1	2502-198	5/16-18 X 1 HHCS GR.5 ZP	1
2	2502-244	3/8-16 X 1-1/4 HHCS GR 5 ZP	1
3	2502-296	1/2-13 X 2-1/2 HHCS GR5 ZP	1
4	2502-327	5/8-11 X 5 HHCS GR.5 ZP	1
5	2502-351	1/2-13 X 2 HHCS GR.5 ZP	1
6	2502-364	1/2-13 X 4 HHCS GR. 5 ZP	1
7	2502-405	3/4-10 X 8 HHCS GR. 5 ZP	1
8	2502-426	3/4-10 X 6 HHFS GR8, ZP	1
9	2502-525	3/4-10 X 16 HHCS GR. 5 ZP, 3" THREAD LENGTH	1
10	2506-306	1/2-13 X 1-1/2 #3 REPAIRPLWBLT	6
11	2520-253	3/8-16 JAM HEX NUT ZP	1
12	2520-357	1/2-13 LOCK HEX NUT, GR A, ZP	6
13	2520-363	1/2-13 NYL INSERT LOCKNUT, GR 2	4
14	2520-516	3/4-10NYLON INSERT LCKNT, GR 2, ZP	1
15	2520-603	5/8-11 HEX TOP LOCK	1
16	2520-604	3/4-10 HEX TOP LOCK	2
17	2525-201	5/16 MED. LOCKWASHER ZP.	1
18	2526-351	1/2 STANDARD FLATWASHER ZP	2
19	2526-453	5/8 SAE FLATWASHER ZP	3
20	2526-501	3/4 STANDARD FLATWASHER ZP	2
21	2530-208	3/8 X 2-1/2 ROLL PIN ZP	1
22	2570-069	40MM BEARING - AN212132 (5203KYY2)	1
23	2570-447	EYEBOLT, 1/2-13 X 4-1/4	1
24	2571-279	.256 X 22.60" COULTER BLADE	1
25	2967-302	SPACER, 3/4" PLATED	1
26	2986-342	COMPRESSION SPRING, AVENGER	1
27	2986-405	SPRING BUSHING	1
(A) 28	2987-395-L	PAINTED LH CLSNG ARM TORS SPRG	1
29	2987-407	LH SIDE KNIFE CAST, MACH W/CARB	1
30	3000-344	2-1/2" SPRING#LHL-1500B-2, BLK	1
(A) 31	10000-111-LH	MAGNUM LH MAIN ARM, ASSEMBLY	1
32	10000-112	WW ARM W/ BUSHING, ASSY	1
(A) 33	10000-113-LH	CLOSING ARM LH W/ BUSHING	1
34	10000-114	WIPER WHEEL	1
35	10000-203	CLOSING PIVOT BUSHING	1
(A) 36	10000-250-LH	BEAVERTAIL LH W.A., 2IN	1
37	10000-302	MOUNT OFFEST MAGNUM, MACHINED	1
38	10000-307	MAIN PIVOT PIN	1
39	10000-309	BUSHING, WIPER WHEEL PIVOT	1
(A) 40	10000-317-LH	MAGNUM WIPER WHEEL TORSION SPRING, LH	1
41	10000-333	SPRING LIMITER BUSHING	1
42	10000-347	PIVOT BUSHING	3

**MANUFACTURED 7/2016 – 2/2018**

**PART IDENTIFICATION**  
**10000-100-LH (SHOWN) & 10000-1000-RH**  
**MAGNUM BASE ASSEMBLY**

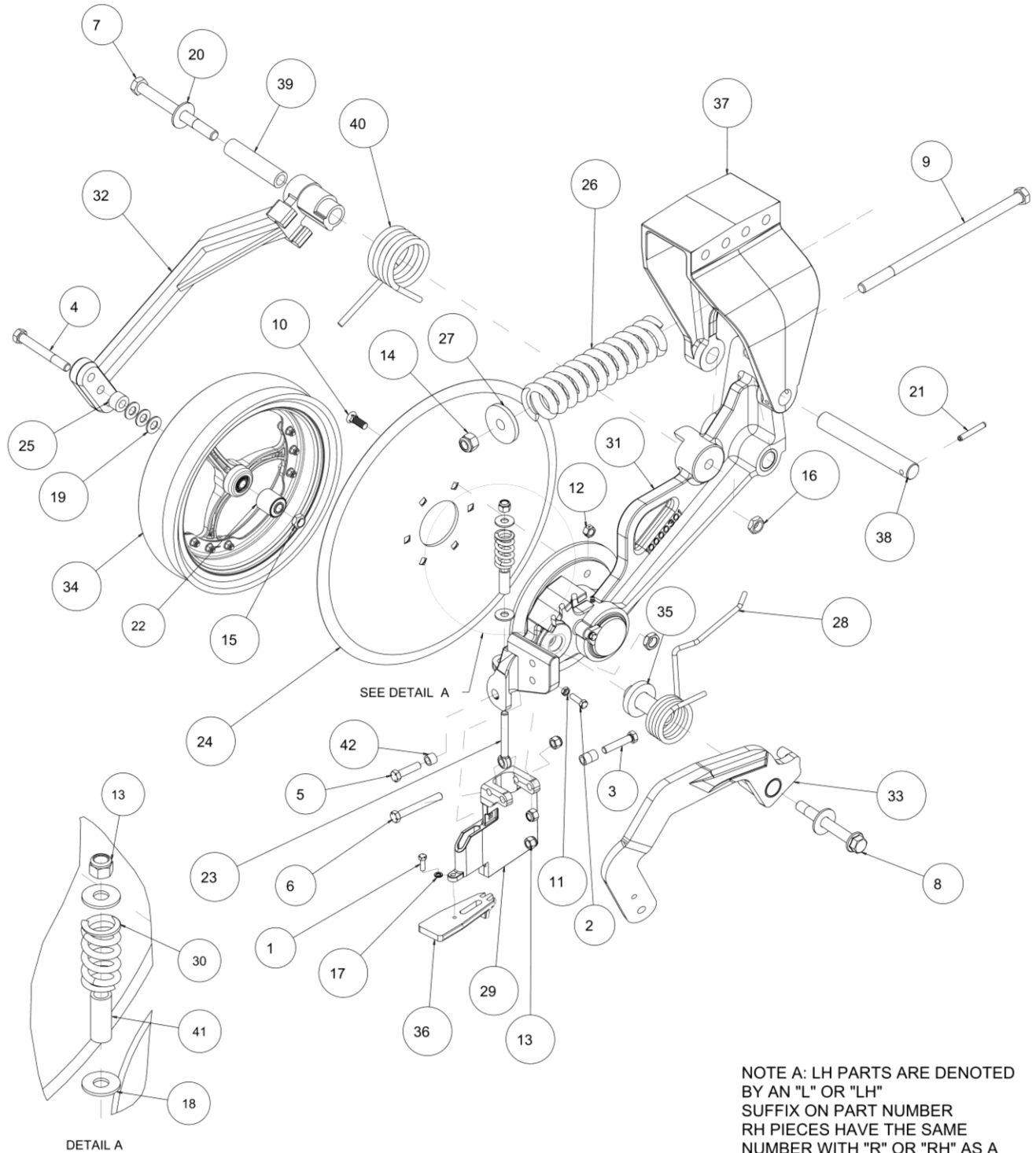

**MANUFACTURED 7/2016 – 2/2018**

# PART IDENTIFICATION

## 10000-100-LH

ITEM	PART NO.	DESCRIPTION	QTY
1	2502-206	5/16-18 X 1-1/2 HHCS GRADE 5	1
2	2502-244	3/8-16 X 1-1/4 HHCS GRADE 5	1
3	2502-296	1/2-13 X 2-1/2 HHCS GRADE 5	1
4	2502-327	5/8-11 X 5 HHCS GRADE 5	1
5	2502-351	1/2-13 X 2 HHCS GRADE 5	1
6	2502-405	3/4-10 X 8 HHCS GRADE 5	1
7	2502-426	3/4-10 X 6 HHCS GRADE 8	1
8	2502-525	3/4-10 X 6 HHFS GRADE 5 3" THREAD	1
9	2506-306	1/2-13 X 1-1/2 #3 PLOW BOLT	6
10	2520-253	3/8-16 JAM HEX NUT	1
11	2520-359	1/2-13 NYLON LOCK HEX NUT GRADE N8	3
12	2520-362	1/2-13 LOCK HEX NUT GRADE C	6
13	2520-516	3/4-10 NYLON LOCK HEX NUT	1
14	2520-603	5/8-11 TOP LOCK HEX NUT	1
15	2520-604	3/4-10 TOP LOCK HEX NUT	2
16	2525-201	5/16 LOCKWASHER	1
17	2526-351	1/2 STANDARD FLAT WASHER	2
18	2526-352	1/2 SAE FLAT WASHER	1
19	2526-453	5/8 SAE FLAT WASHER	3
20	2526-501	3/4 STANDARD FLAT WASHER	2
21	2530-208	3/8 X 2-1/2 ROLL PIN	1
22	2531-107	1/8 X 1 COTTER PIN	1
23	2570-447	EYEBOLT 1/2-13 X 4-1/4	1
24	2571-279	SMOOTH BLADE .256 X 22.60"	1
25	2967-302	SPACER 3/4"	1
26	2986-342	COMPRESSION SPRING	1
27	2986-405	SPRING BUSHING	1
28	2987-395-L	LEFT HAND TORSION SPRING	1
29	2987-407	LEFT HAND KNIFE	1
30	3000-344	2-1/2" COMPRESSION SPRING	1
31	10000-111-LH	LEFT HAND MAIN ARM ASSEMBLY	1
32	10000-112	WIPER WHEEL ARM ASSEMBLY	1
33	10000-113-LH	LEFT HAND CLOSING PIVOT ARM	1
34	6000-071	WIPER WHEEL	1
	2570-069	BEARING	1
35	10000-203	BUSHING, CLOSING ARM PIVOT	1
36	10000-250-LH	LEFT HAND BEAVERTAIL SEALER	1
37	10000-302	MOUNT OFFSET	1
38	10000-307	PIVOT PIN 1.25" X 9.125"	1
39	10000-309	BUSHING, WIPER WHEEL PIVOT	1
40	10000-317-LH	SPRING, LEFT HAND WIPER WHEEL TORSION	1
41	10000-333	BUSHING, SPRING LIMITER	1
42	10000-347	BUSHING, KNIFE PIVOT	3
43	10000-355	PIN, 1/2 X 3.5	1

**MANUFACTURED 3/2018 – PRESENT**

# PART IDENTIFICATION

## 10000-100-LH

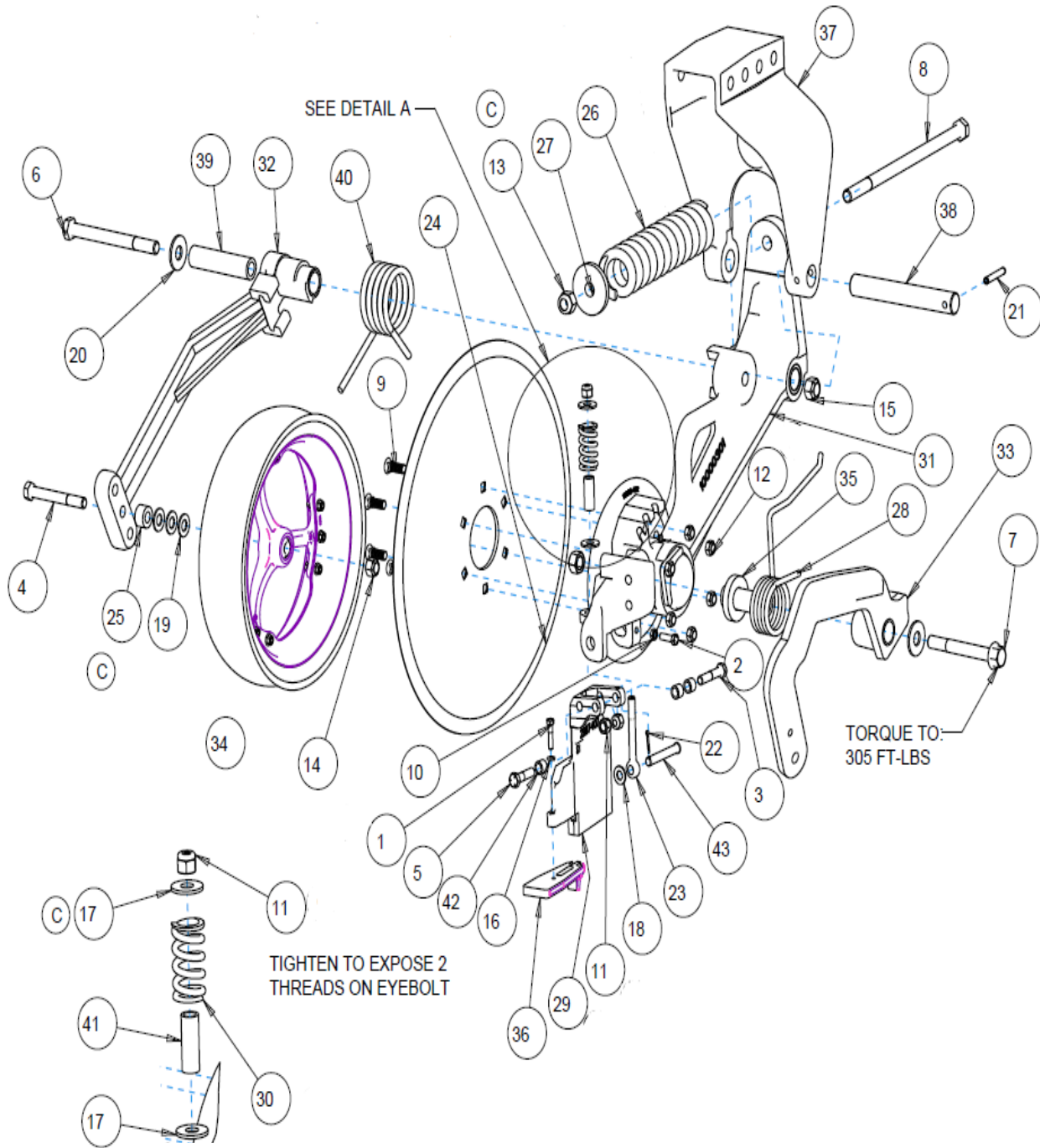

**MANUFACTURED 3/2018 - PRESENT**

# PART IDENTIFICATION

## 10000-100-RH

ITEM	PART NO.	DESCRIPTION	QTY
1	2502-206	5/16-18 X 1-1/2 HHCS GRADE 5	1
2	2502-244	3/8-16 X 1-1/4 HHCS GRADE 5	1
3	2502-296	1/2-13 X 2-1/2 HHCS GRADE 5	1
4	2502-327	5/8-11 X 5 HHCS GRADE 5	1
5	2502-351	1/2-13 X 2 HHCS GRADE 5	1
6	2502-405	3/4-10 X 8 HHCS GRADE 5	1
7	2502-426	3/4-10 X 6 HHCS GRADE 8	1
8	2502-525	3/4-10 X 6 HHFS GRADE 5 3" THREAD	1
9	2506-306	1/2-13 X 1-1/2 #3 PLOW BOLT	6
10	2520-253	3/8-16 JAM HEX NUT	1
11	2520-359	1/2-13 NYLON LOCK HEX NUT GRADE N8	3
12	2520-362	1/2-13 LOCK NUT GRADE C	6
13	2520-516	3/4-10 NYLON LOCK HEX NUT	1
14	2520-603	5/8-11 TOP LOCK HEX NUT	1
15	2520-604	3/4-10 TOP LOCK HEX NUT	2
16	2525-201	5/16 LOCKWASHER	1
17	2526-351	1/2 STANDARD FLAT WASHER	2
18	2526-352	1/2 SAE FLAT WASHER	1
19	2526-453	5/8 SAE FLAT WASHER	3
20	2526-501	3/4 STANDARD FLAT WASHER	2
21	2530-208	3/8 X 2-1/2 ROLL PIN	1
22	2531-107	1/8 X 1 COTTER PIN	1
23	2570-447	EYEBOLT 1/2-13 X 4-1/4	1
24	2571-279	SMOOTH BLADE .256 X 22.60"	1
25	2967-302	SPACER 3/4"	1
26	2986-342	COMPRESSION SPRING	1
27	2986-405	SPRING BUSHING	1
28	2987-395-R	RIGHT HAND TORSION SPRING	1
29	2987-406	RIGHT HAND KNIFE	1
30	3000-344	2-1/2" COMPRESSION SPRING	1
31	10000-111-RH	RIGHT HAND MAIN ARM ASSEMBLY	1
32	10000-112	WIPER WHEEL ARM ASSEMBLY	1
33	10000-113-RH	RIGHT HAND CLOSING PIVOT ARM	1
34	6000-071	WIPER WHEEL	1
	2570-069	BEARING	1
35	10000-203	BUSHING, CLOSING ARM PIVOT	1
36	10000-250-RH	RIGHT HAND BEAVERTAIL SEALER	1
37	10000-302	MOUNT OFFSET	1
38	10000-307	PIVOT PIN 1.25" X 9.125"	1
39	10000-309	BUSHING, WIPER WHEEL PIVOT	1
40	10000-317-RH	SPRING, RIGHT HAND WIPER WHEEL TORSION	1
41	10000-333	BUSHING, SPRING LIMITER	1
42	10000-347	BUSHING, KNIFE PIVOT	3
43	10000-355	PIN, 1/2 X 3.5	1

**MANUFACTURED 3/2018 – PRESENT**

# PART IDENTIFICATION

## 10000-100-RH

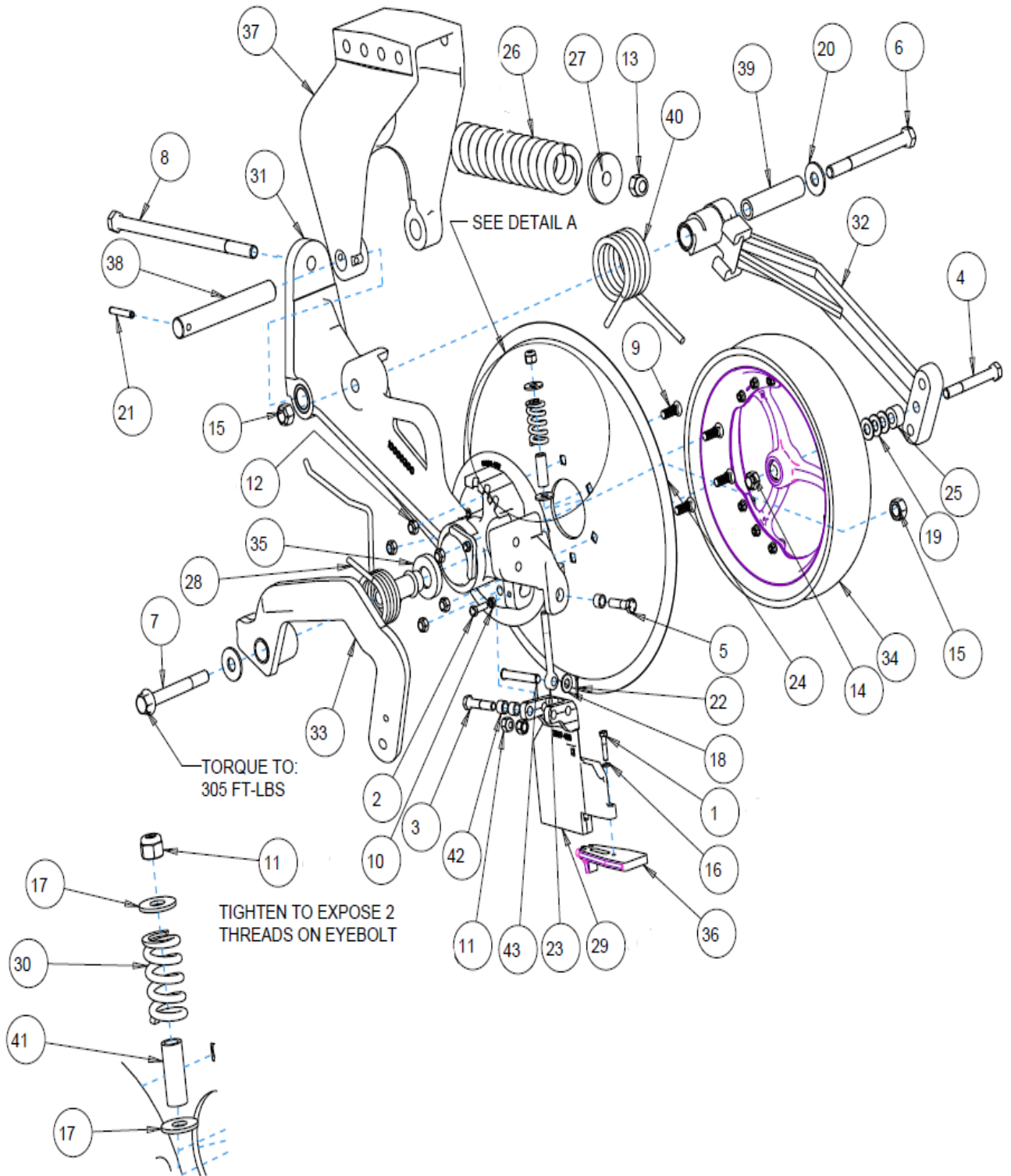



PART IDENTIFICATION  
 10000-111-LH (SHOWN)  
 10000-111-RH

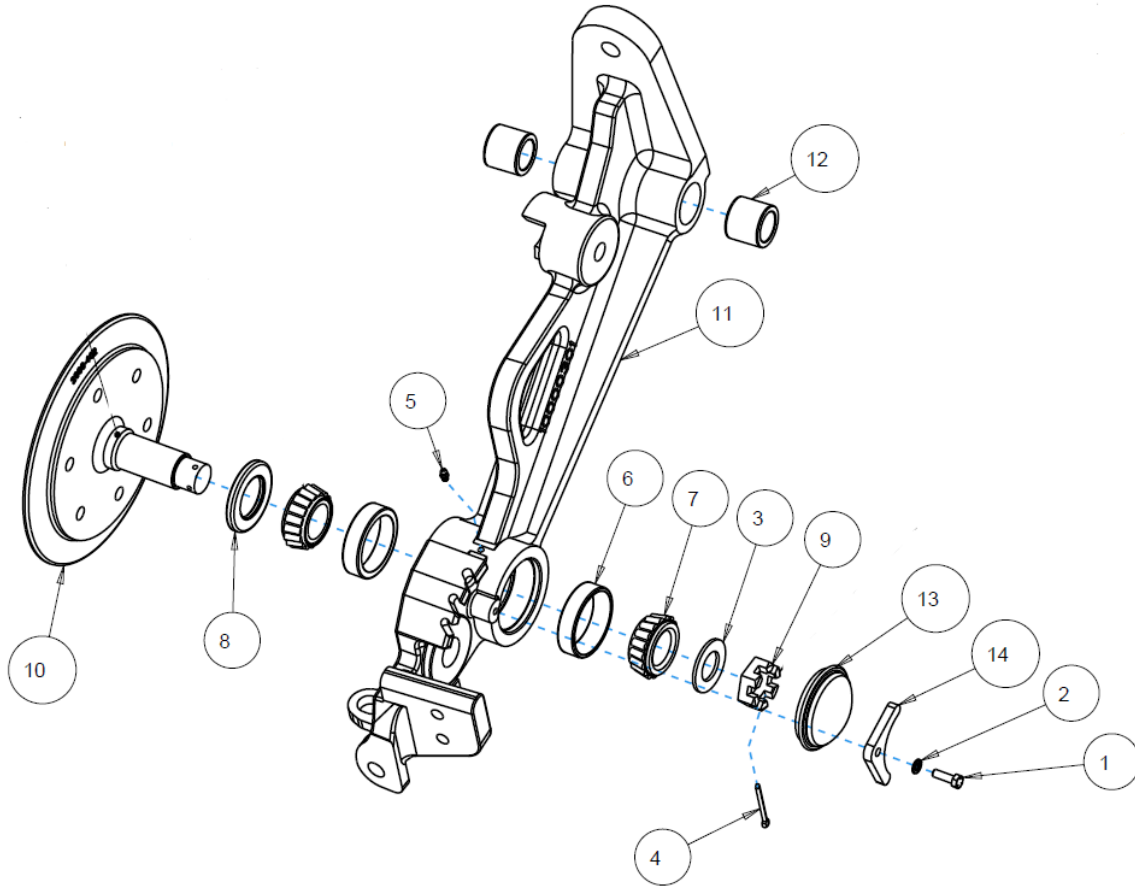

ITEM	PART NO.	DESCRIPTION	QTY
1	2502-198	5/16-18 X 1 HHCS GRADE 5	1
2	2525-201	5/16 LOCKWASHER	1
3	2526-562	1-17/64 ID X 2-1/4 OD X 10 GAUGE MACHINE BUSHING	1
4	2531-124	3/16 X 2 COTTER PIN	1
5	2533-110	1/4-28 GREASE FITTING STRAIGHT SELF-TAP	1
6	2550-056	CUP, KOYO #2729	2
7	2550-057	BEARING, KOYO #2788R	2
8	2550-058	SEAL, CR #17699	1
9	2986-329	1-1/4-12 CASTLE HEX NUT GRADE 2	1
10	<b>*2986-402*</b>	SPINDLE (SUB: <b>10000-121 SERVICE KIT-SPINDLE AND SEAL</b> )	1
11	10000-301	LEFT HAND MAGNUM ARM (SHOWN)	1
	10000-300	RIGHT HAND MAGNUM ARM	1
12	10000-313	SLEEVE 1.75 OD X 1.25 ID X 1.50 WIDTH	2
13	10000-314	HUB CAP	1
14	10000-315	HUB CAP RETAINER	1

**MANUFACTURED 06/2016 – 06-2023**

**PART IDENTIFICATION**  
**10000-111-LH (SHOWN)**  
**10000-111-RH**

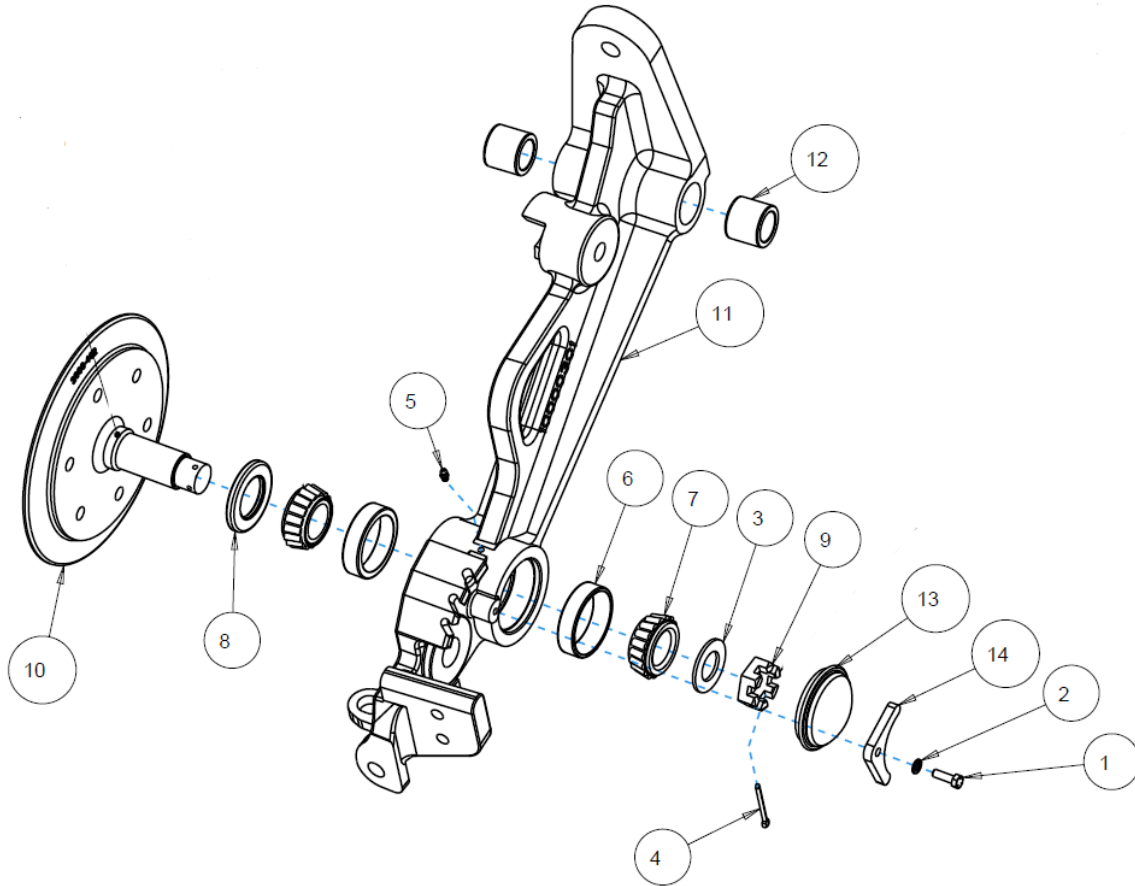

ITEM	PART NO.	DESCRIPTION	QTY
1	2502-198	5/16-18 X 1 HHCS GRADE 5	1
2	2525-201	5/16 LOCKWASHER	1
3	2526-562	1-17/64 ID X 2-1/4 OD X 10 GAUGE MACHINE BUSHING	1
4	2531-124	3/16 X 2 COTTER PIN	1
5	2533-110	1/4-28 GREASE FITTING STRAIGHT SELF-TAP	1
6	2550-056	CUP, KOYO #2729	2
7	2550-057	BEARING, KOYO #2788R	2
8	2550-073	SEAL, CR #21159	1
9	2986-329	1-1/4-12 CASTLE HEX NUT GRADE 2	1
10	10000-402	SPINDLE	1
11	10000-301	LEFT HAND MAGNUM ARM (SHOWN)	1
	10000-300	RIGHT HAND MAGNUM ARM	1
12	10000-313	SLEEVE 1.75 OD X 1.25 ID X 1.50 WIDTH	2
13	10000-314	HUB CAP	1
14	10000-315	HUB CAP RETAINER	1

**MANUFACTURED 06/2023 – PRESENT**

PART IDENTIFICATION

10000-112  
MAGNUM WHEEL ARM ASSEMBLY

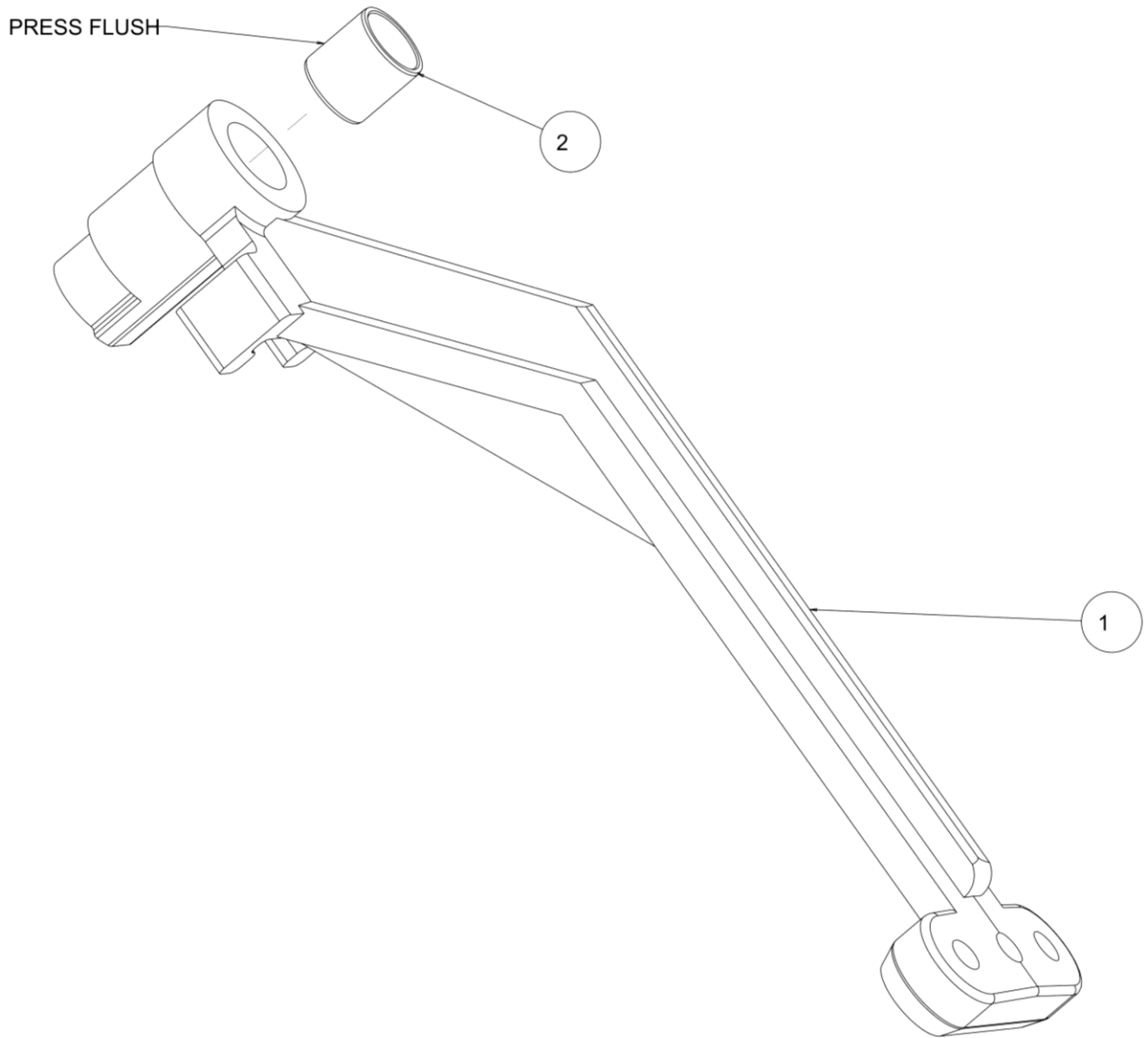

ITEM	PART #	DESCRIPTION	QTY
1	10000-303	WIPER WHEEL ARM, MACHINED	1
2	10000-316	BEARING SLEEVE 1.5 OD X 1.25 ID X 1.50	1

**MANUFACTURED 06/2016 – 06-2023**

**PART IDENTIFICATION**  
**10000-112A**  
**WIPER WHEEL ARM ASSEMBLY**

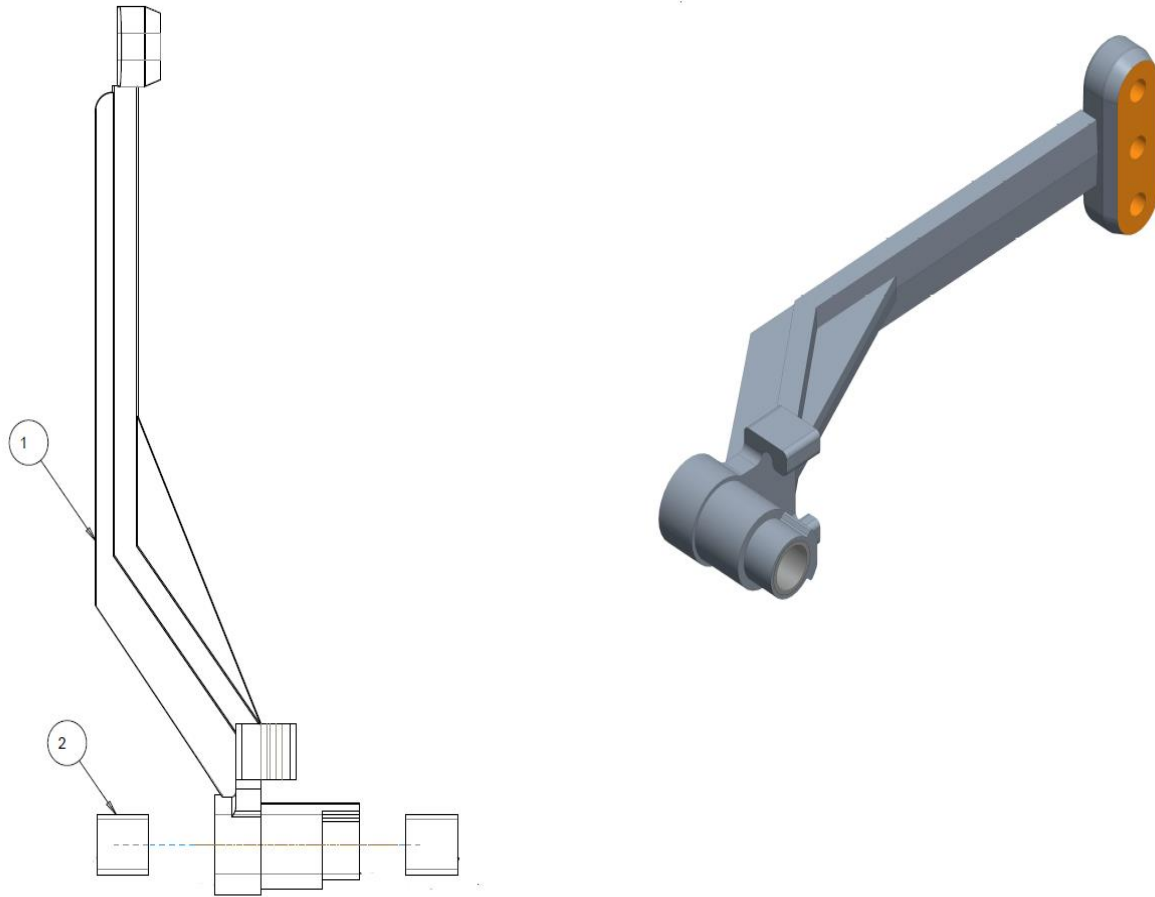

ITEM	PART NO.	DESCRIPTION	QTY
1	10000-303	WIPER WHEEL ARM	1
2	10000-316	SLEEVE 1.5 OD X 1.25 ID X 1.50 WIDTH	2

**MANUFACTURED 06/2023 – PRESENT**

**PART IDENTIFICATION**  
**10000-113-LH(SHOWN) AND 10000-113-RH**  
**CLOSING WHEEL ARM ASSEMBLY**

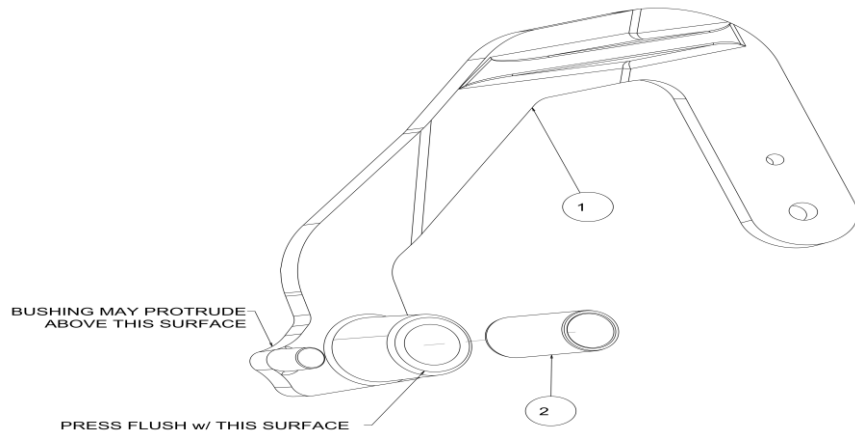

ITEM	PART NO.	DESCRIPTION	QTY
1	10000-304	LEFT HAND CLOSE WHEEL ARM (SHOWN)	1
	10000-305	RIGHT HAND CLOSE WHEEL ARM	1
2	10000-318	SLEEVE 1.50 OD X 1.25 ID X 2.70 WIDTH	1

**10000-114**  
07/2016-07/2023

PARTS IDENTIFICATION

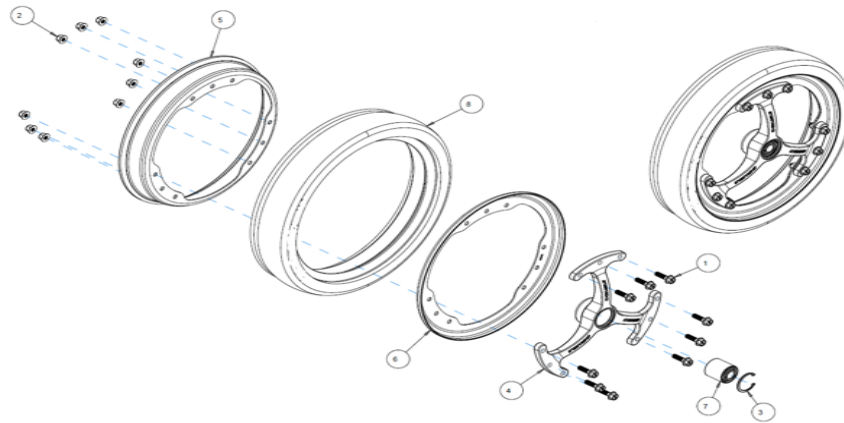

PART LIST:

- |   |                                 |
|---|---------------------------------|
| 1. 2502-228 M8 X 30 HEX HEAD FLANGE SCREW 8.8 | 5. 2570-148 4" X 16" WHEEL HALF |
| 2. 2520-207 M8 NYLON FLANGE LOCK NUT          | 6. 2570-149 3" X 16" WHEEL HALF |
| 3. 2550-527 SNAP RING                         | 7. 2570-069 BEARING             |
| 4. 2570-090 TRI-SPOKE HUB                     | 8. 2987-399 TIRE 4.5" X 16"     |
|   | 2570-091 TIRE 3" X 16"          |

**6000-071**  
08/2023-PRESENT

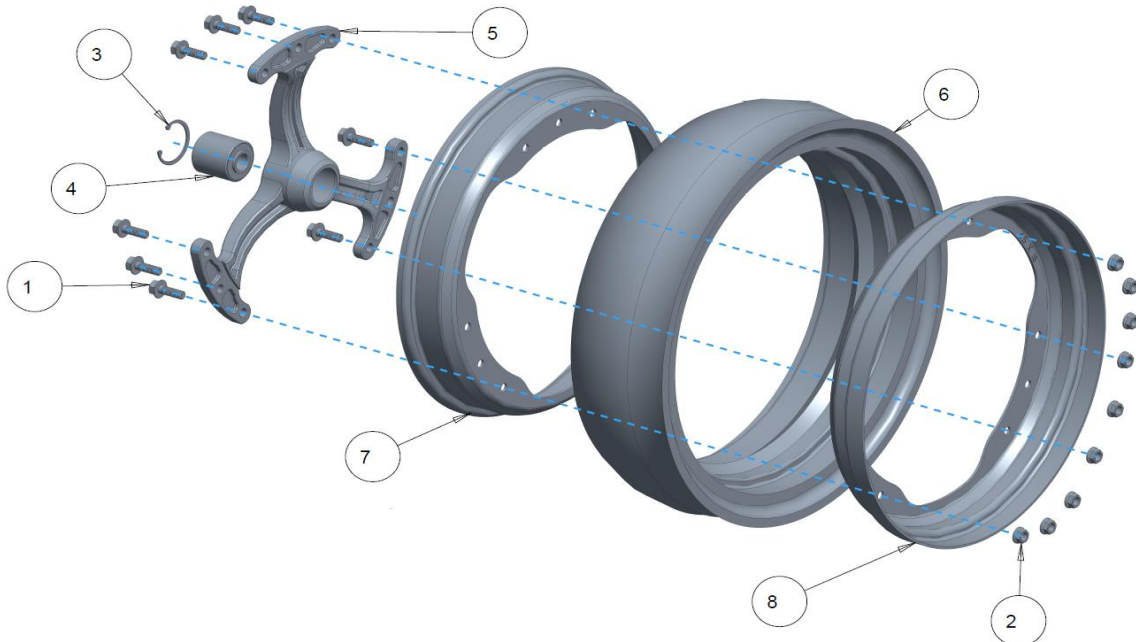

1	2502-229	FLANGE HEAD BOLT M8X1.25X25MM	9	5	6000-600	THREE SPOKE HUB	1
2	2520-208	FLANGE HEX NUT	9	6	6000-602	4.5"X16 TIRE	1
3	2550-527	SNAP RING	1	7	6000-604	WHEEL HALF	1
4	2570-069	40MM BEARING	1	8	6000-605	INNER WHEEL HALF	1

## PART IDENTIFICATION

2987-142-L (SHOWN) & 2987-142-R  
CLOSING WHEEL ASSEMBLY

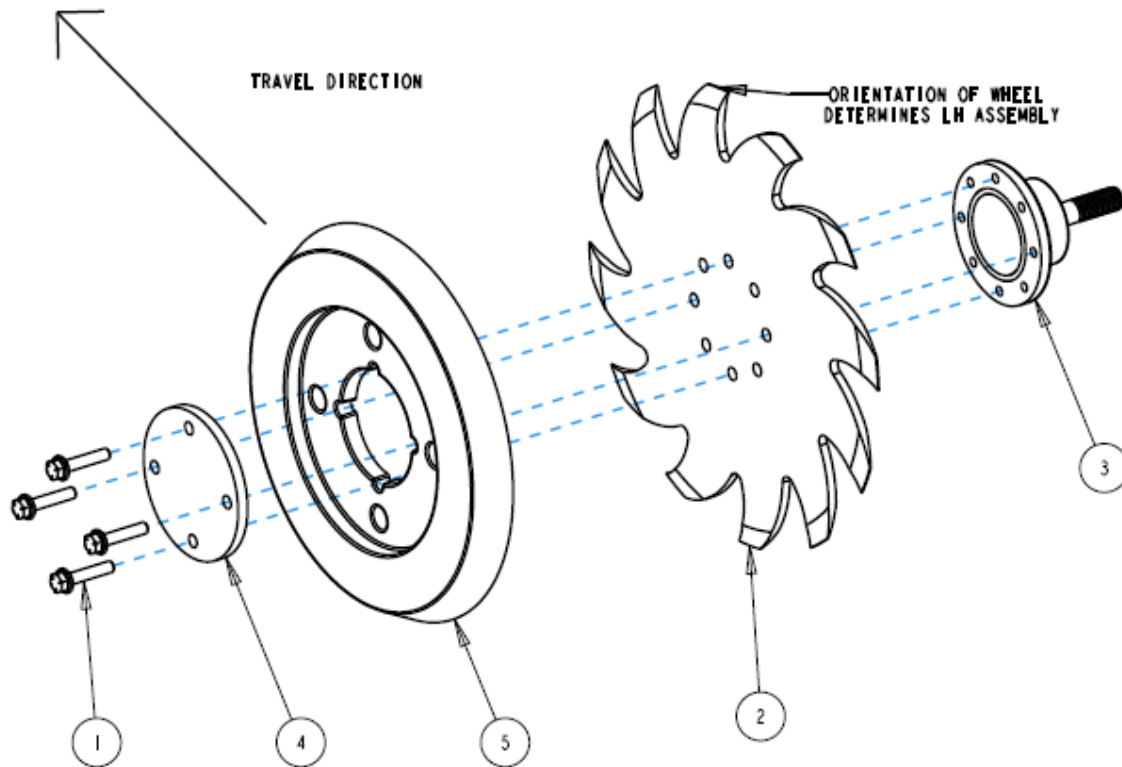

ITEM	PART NO.	DESCRIPTION	QTY.
1	2502-225	5/16-18 X 1-1/2 HHFS GR. 5	4
2	2571-286	SHARKTOOTH WHEEL	1
3	2965-501	HUB ASSEMBLY 2.406" SPINDLE	1
4	2965-503	HUB CAP	1
5	2987-396	CAST PRESS WHEEL	1

**MANUFACTURED 06/2021 – PRESENT**

## PART IDENTIFICATION

### 2987-142-L (SHOWN) & 2987-142-R CLOSING WHEEL ASSEMBLY

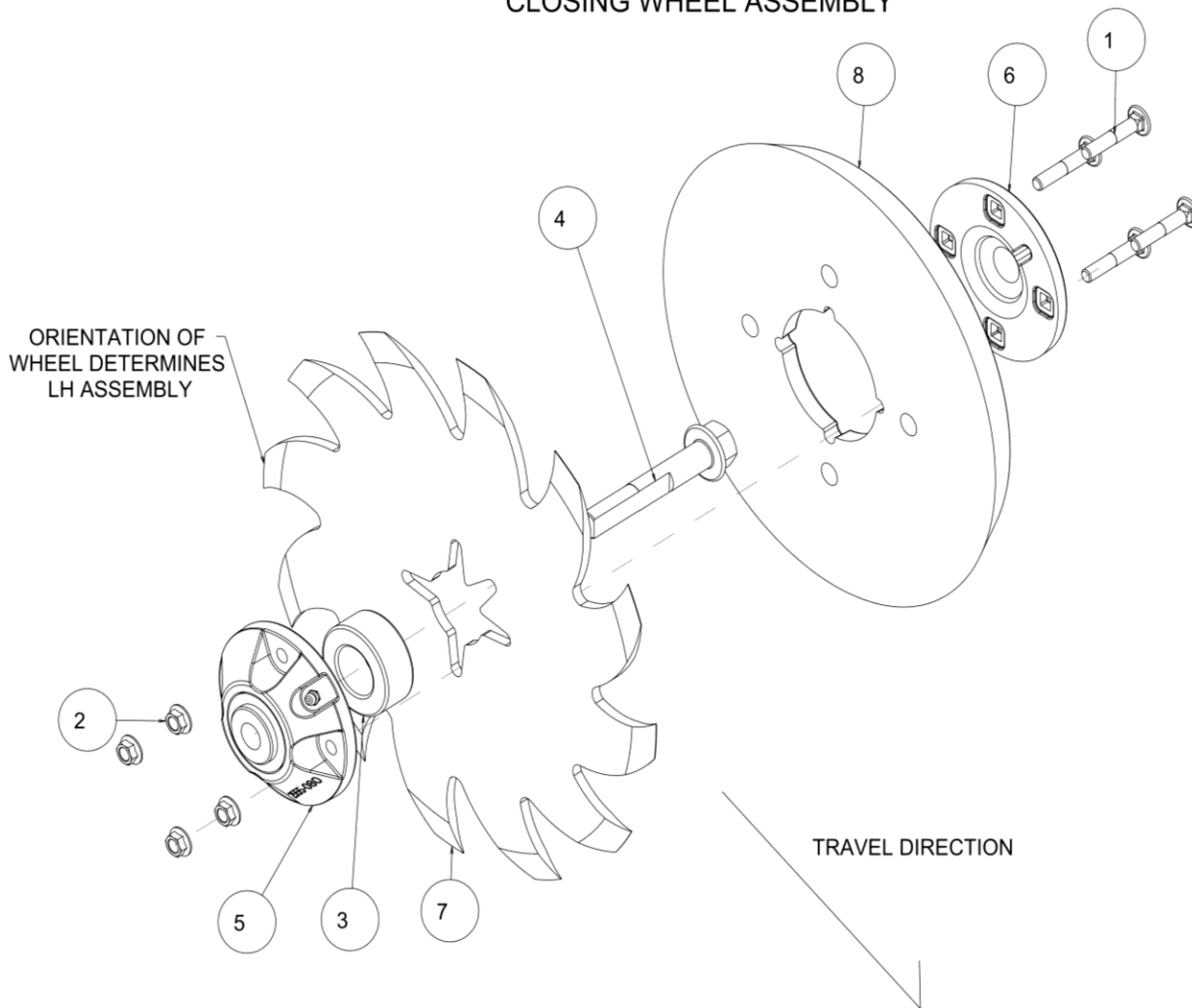

ITEM	PART NO.	DESCRIPTION	QTY.
1	2502-209	5/16-18 X 1-13/4 GR. 5	4
2	2520-206	5/16-18 FLANGE LOCK NUT	4
3	2570-594	BEARING	1
4	2570-742	D-BOLT FLANGED 5/8-11 X 3.812" GR. 8	1
5	2965-128	HUB ASSEMBLY	1
	2550-069	SEAL	1
	2570-594	BEARING	1
	2570-715	INSERT	1
	2965-351	HUB	1
6	2965-352	HUB CAP	1
7	2967-602	13" SHARK TOOTH	1
8	2987-396	PRESS WHEEL	1

**MANUFACTURED 06/2016 – 06/2021**



# PARTS IDENTIFICATION

## 2965-120

### HUB UPDATE KIT

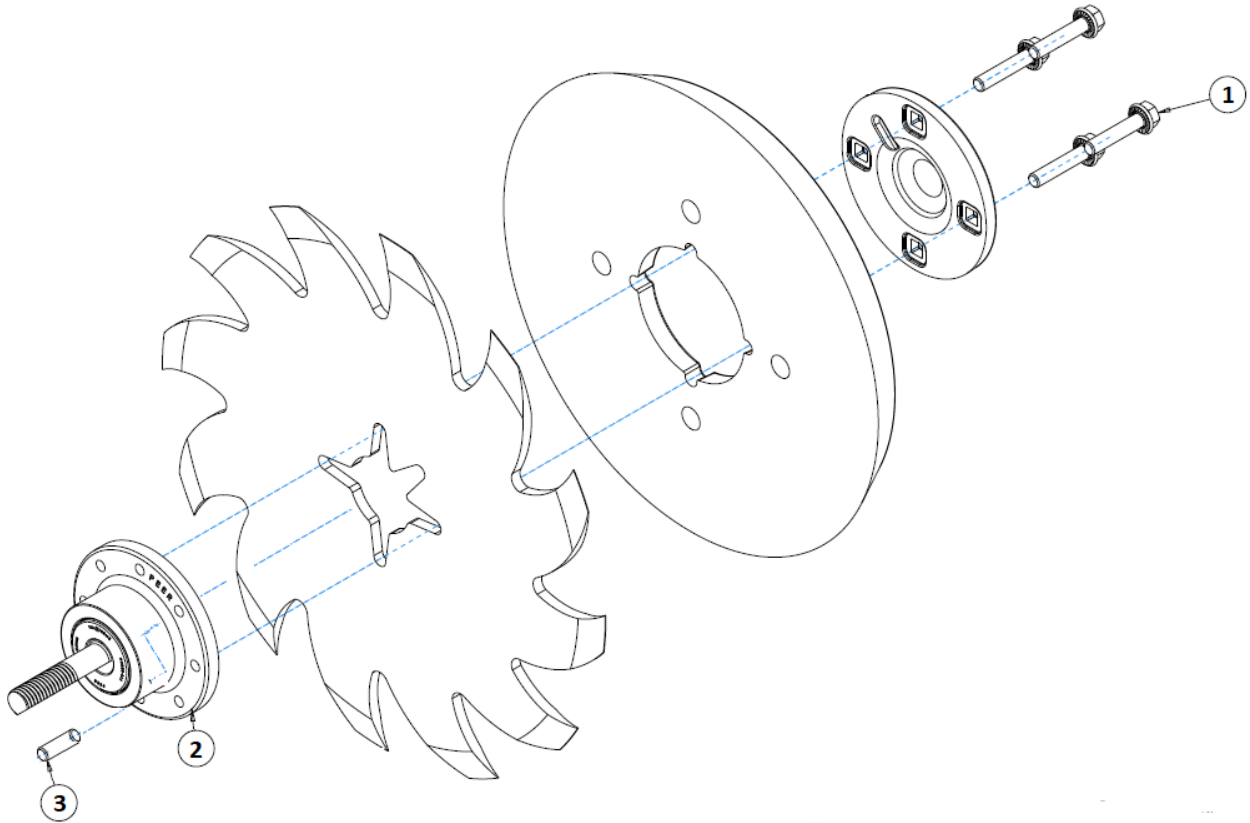

ITEM	PART NO.	DESCRIPTION	QTY.
1	2502-225	5/16-18 X 1-1/2 HHFS GR. 5	4
2	2965-501	HUB ASSEMBLY 2.406" SPINDLE	1
3	2940-560	SET SCREW .313-18 X .75	1

# PARTS IDENTIFICATION

10000-080-LH

## RESIDUE MANAGER MOUNT KIT

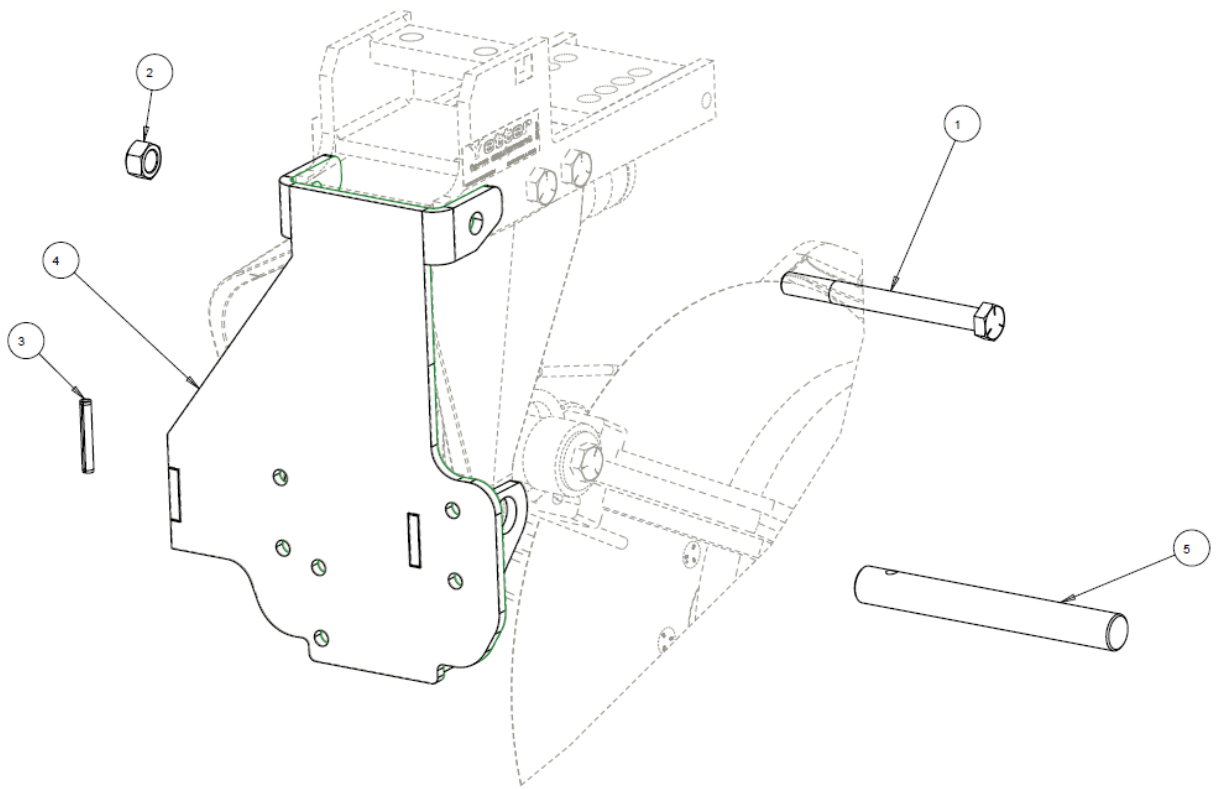

ITEM	PART NO.	DESCRIPTION	QTY
1	2502-405	3/4-10 X 8 HHCS GR. 5 ZP	1
2	2520-604	3/4-10 HEX TOP LOCK, GR. C, ZP	1
3	2530-208	3/8 X 2-1/2 ROLL PIN ZP	1
4	10000-207-LH	LH RESIDUE MANAGER MOUNT	1
5	10000-354	MAIN PIVOT PIN, ZP	1

# PARTS IDENTIFICATION

10000-080-RH

## RESIDUE MANAGER MOUNT KIT

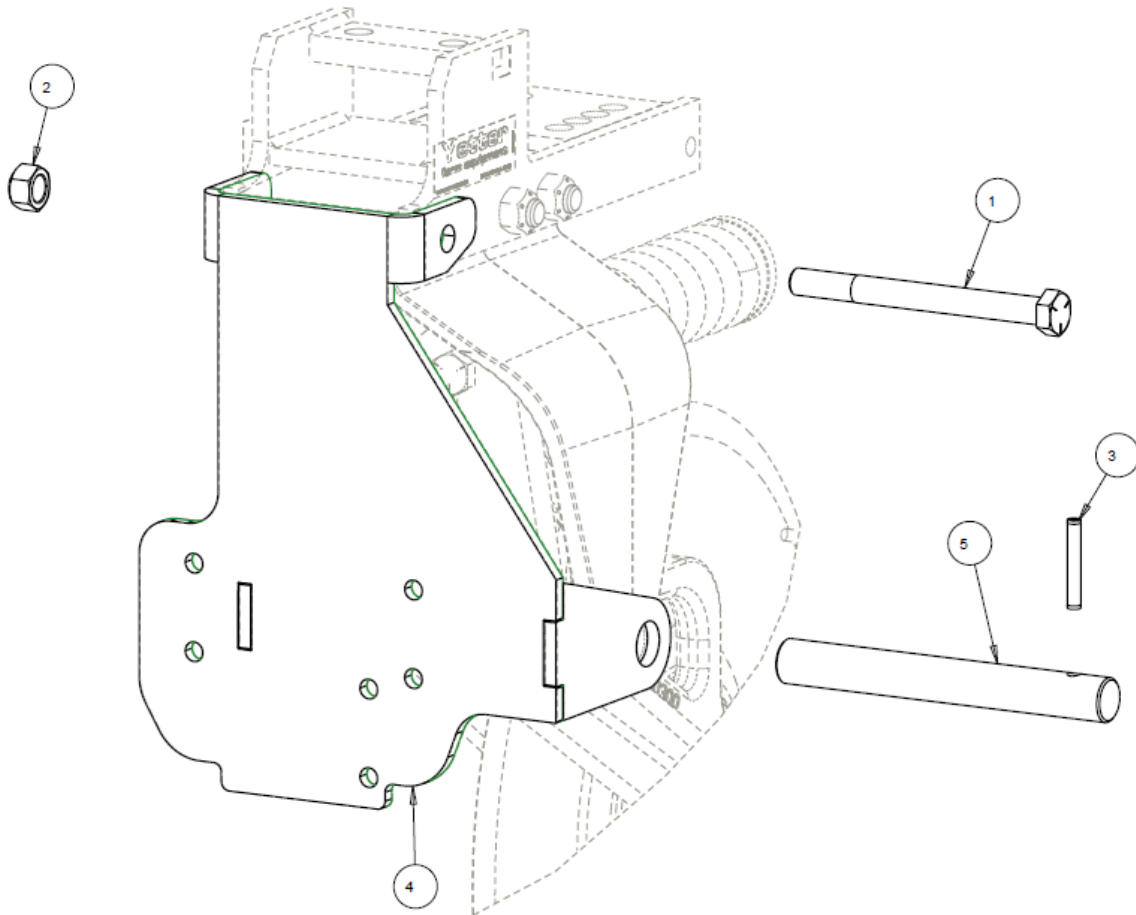

ITEM	PART NO.	DESCRIPTION	QTY
1	2502-405	3/4-10 X 8 HHCS GR. 5 ZP	1
2	2520-604	3/4-10 HEX TOP LOCK, GR. C, ZP	1
3	2530-208	3/8 X 2-1/2 ROLL PIN ZP	1
4	10000-207-RH	RH RESIDUE MANAGER MOUNT	1
5	10000-354	MAIN PIVOT PIN, ZP	1

## PARTS IDENTIFICATION

### 10000-117 LEFT HAND MAGNUM OFFSET KIT

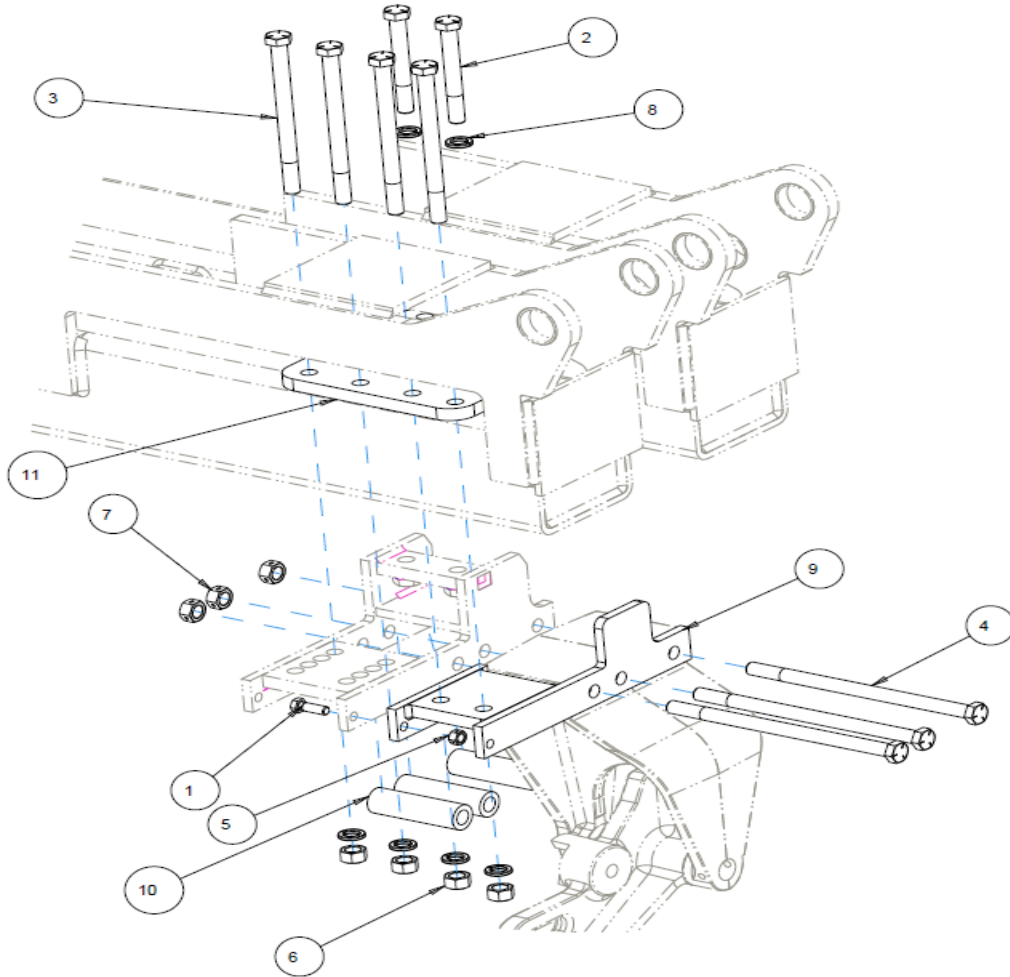

ITEM	PART NO.	DESCRIPTION	QTY
1	2502-294	1/2-13 X 1-1/2 HHCS GR5 ZP	1
2	2502-510	3/4-10 X 6 HHCS GR.5 ZP	2
3	2502-516	3/4-10 X 9-1/2 HHCS GR5 ZP	4
4	2502-526	3/4-10 X 13 HHCS GR 5 ZP	3
5	2520-357	1/2-13 LOCK HEX NUT, GR A, ZP	1
6	2520-506	3/4-10 HEX NUT, GR 8, ZP	4
7	2520-515	3/4-10 LOCK HEX NUT, GR A, ZP	3
8	2525-501	3/4 MED. LOCKWASHER ZP.	6
9	10000-208	OFFSET MOUNT W.A., RH	1
10	10000-356	SUPPORT SPACER	3
11	10000-357	OFFSET MOUNT PLATE	1

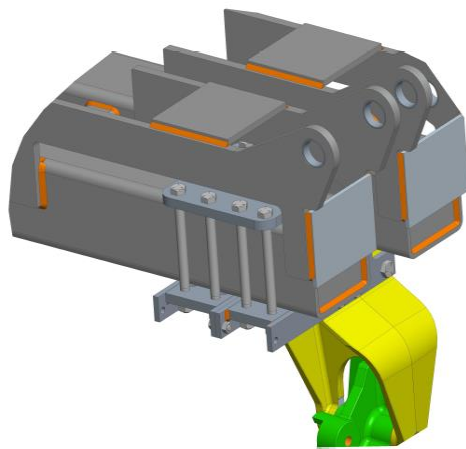

# PARTS IDENTIFICATION

## 10000-118 LEFT HAND MAGNUM OFFSET KIT

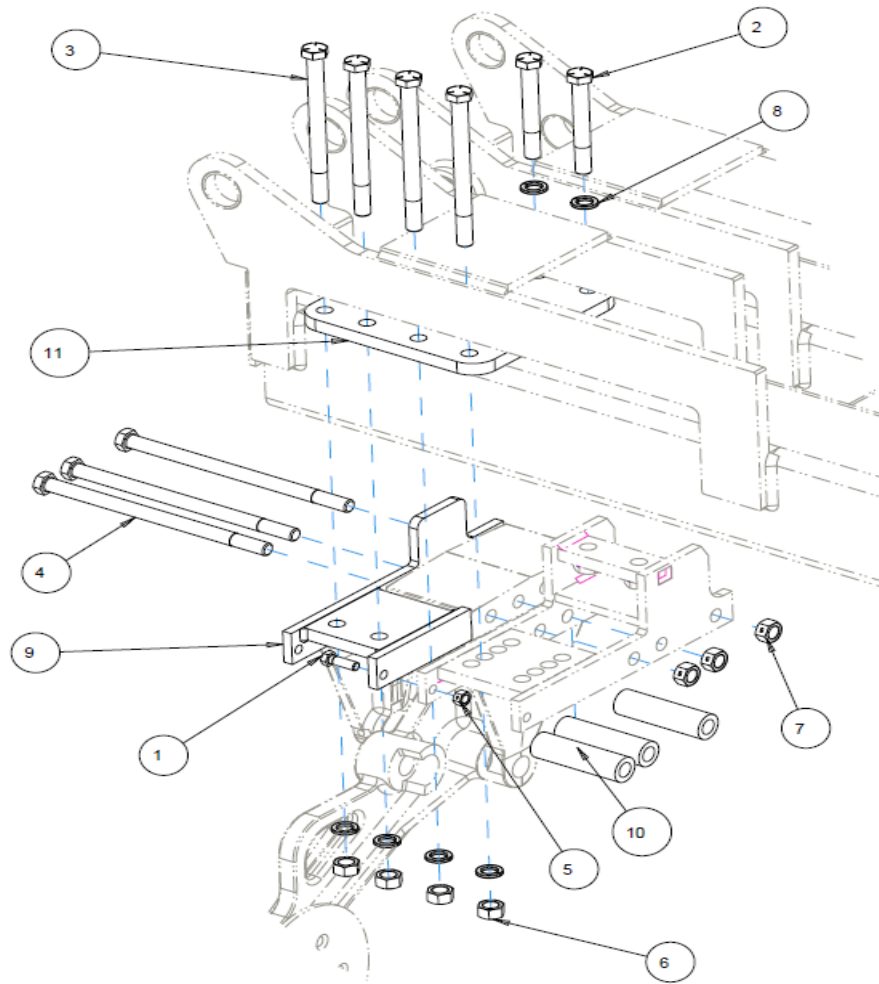

ITEM	PART NO.	DESCRIPTION	QTY
1	2502-294	1/2-13 X 1-1/2 HHCS GR5 ZP	1
2	2502-510	3/4-10 X 6 HHCS GR.5 ZP	2
3	2502-516	3/4-10 X 9-1/2 HHCS GR5 ZP	4
4	2502-526	3/4-10 X 13 HHCS GR 5 ZP	3
5	2520-357	1/2-13 LOCK HEX NUT, GR A, ZP	1
6	2520-506	3/4-10 HEX NUT, GR 8, ZP	4
7	2520-515	3/4-10 LOCK HEX NUT, GR A, ZP	3
8	2525-501	3/4 MED. LOCKWASHER ZP.	6
9	10000-209	OFFSET MOUNT W.A., LH	1
10	10000-356	SUPPORT SPACER	3
11	10000-357	OFFSET MOUNT PLATE	1

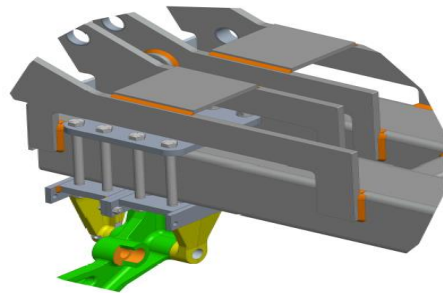

## PART IDENTIFICATION

### 2987-040-R (SHOWN) & 2987-040-L NH3 (3/8" TUBE) FERTILIZER KIT

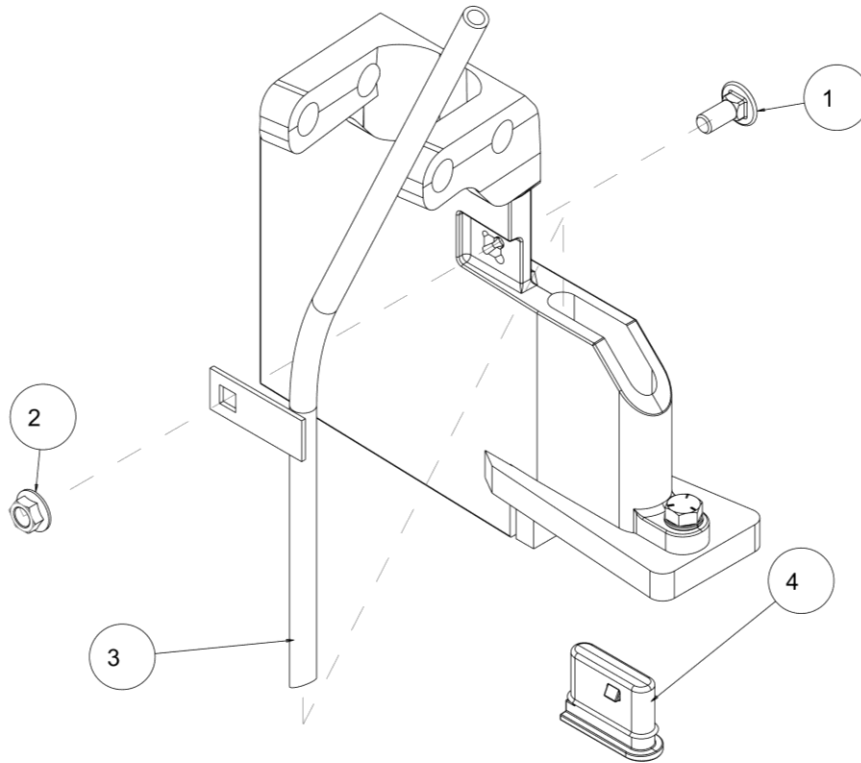

NOTE A: LH PARTS ARE DENOTED BY AN "L" OR "LH" SUFFIX ON PART NUMBER  
RH PIECES HAVE THE SAME NUMBER WITH "R" OR "RH" AS A SUFFIX

ITEM	PART #	DESCRIPTION	QTY
1	2505-205	5/16-18 X 3/4 CARBOLT G5 ZP	1
2	2520-206	5/16-18 FLANGE LOCK NUT	1
(A) 3	2987-248-R	RH FERT TUBE W.A. L/N	1
4	2987-412	FULL PLUG	1

## PART IDENTIFICATION

### 2987-041-R (SHOWN) & 2987-041-L NH3 (3/8" DUAL TUBE) FERTILIZER KIT

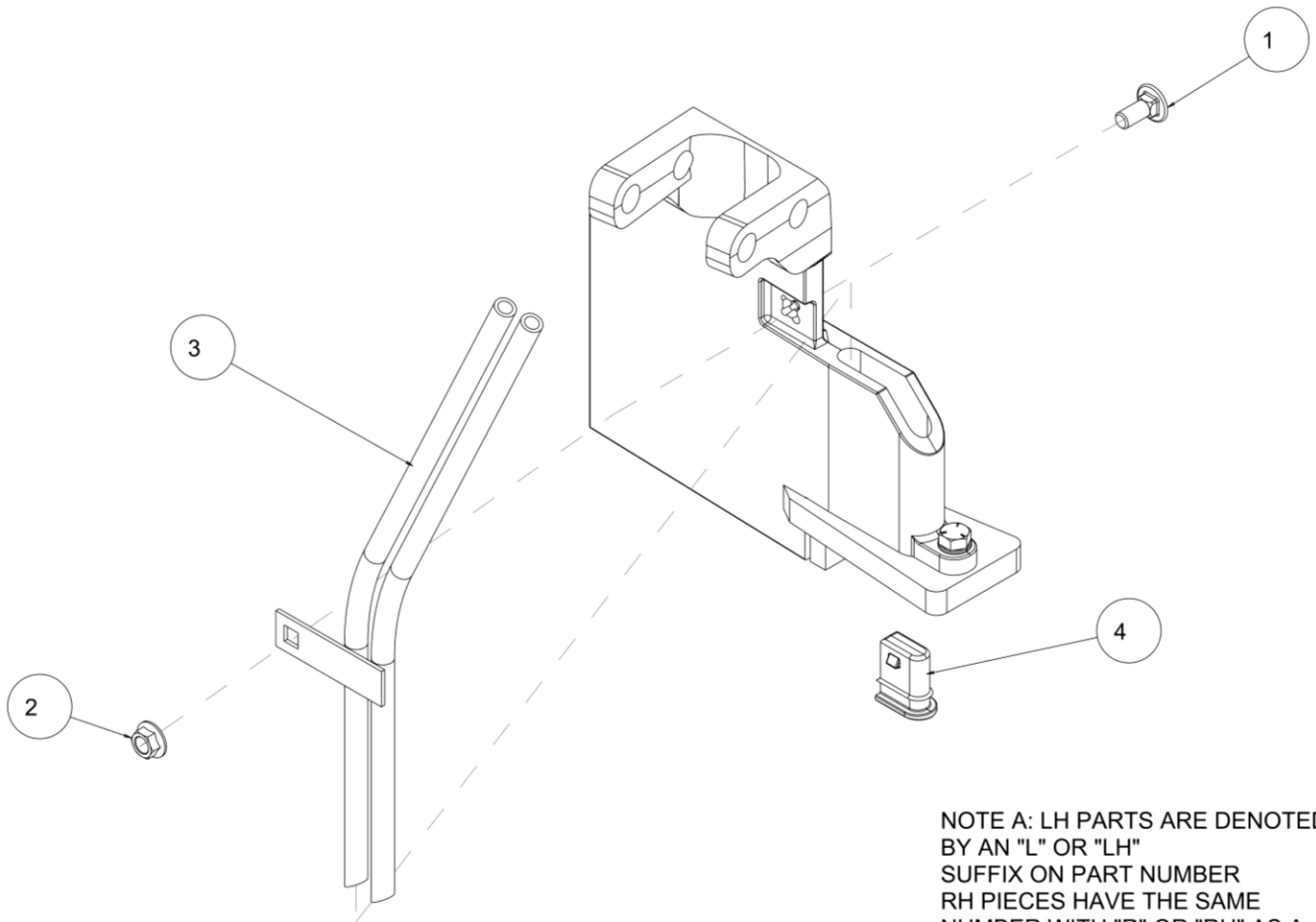

NOTE A: LH PARTS ARE DENOTED  
BY AN "L" OR "LH"  
SUFFIX ON PART NUMBER  
RH PIECES HAVE THE SAME  
NUMBER WITH "R" OR "RH" AS A  
SUFFIX

ITEM	PART #	DESCRIPTION	QTY
1	2505-205	5/16-18 X 3/4 CARBOLT G5 ZP	1
2	2520-206	5/16-18 FLANGE LOCK NUT	1
(A) 3	2987-247-R	RH FERT TUBE W.A. NH3 W/LIQ	1
4	2987-414	3/4 PLUG	1

## PART IDENTIFICATION

2987-042-R (SHOWN) & 2987-042-L  
NH3 w/ VAPOR (3/8" & 3/4" TUBE) KIT

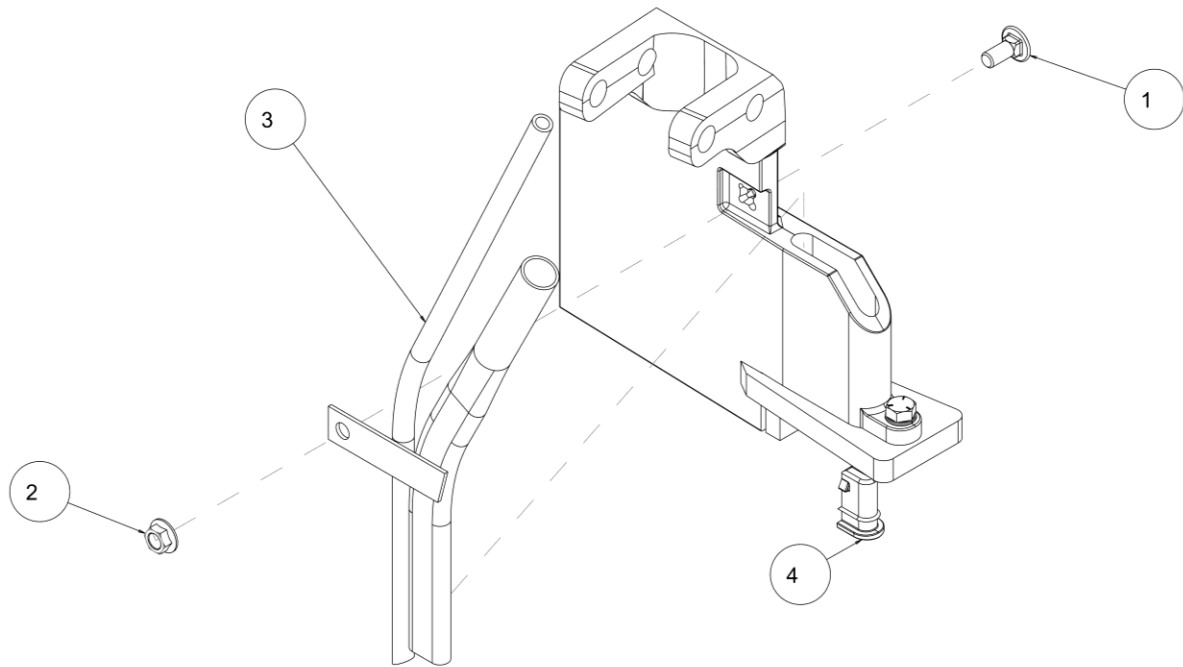

NOTE A: LH PARTS ARE DENOTED  
BY AN "L" OR "LH"  
SUFFIX ON PART NUMBER  
RH PIECES HAVE THE SAME  
NUMBER WITH "R" OR "RH" AS A  
SUFFIX

ITEM	PART #	DESCRIPTION	QTY
1	2505-205	5/16-18 X 3/4 CARBOLT G5 ZP	1
2	2520-206	5/16-18 FLANGE LOCK NUT	1
(A) 3	2987-246-R	RH FERT TUBE W.A. NH3 W/V	1
4	2987-413	1/2 PLUG	1



## PART IDENTIFICATION

2987-043-R (SHOWN) & 2987-043-L  
NH3 w/ VAPOR (3/8" DUAL & 3/4" SINGLE TUBE) KIT

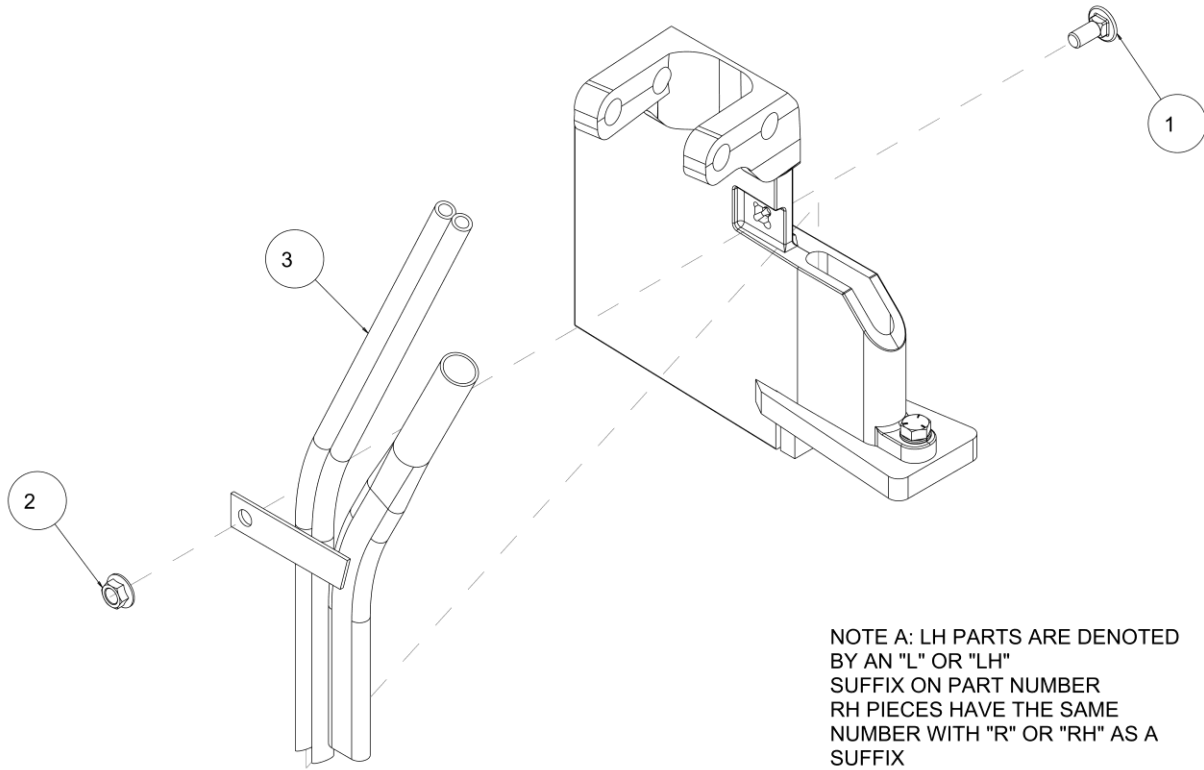

ITEM	PART #	DESCRIPTION	QTY
1	2505-205	5/16-18 X 3/4 CARBOLT G5 ZP	1
2	2520-206	5/16-18 FLANGE LOCK NUT	1
(A) 3	2987-249-R	RH FERT TUBE W.A. NH3, LIQ, VAPOR	1

## PART IDENTIFICATION

2987-044-R (SHOWN) & 2987-044-L  
NH3 VAPOR ONLY (3/4" TUBE) KIT

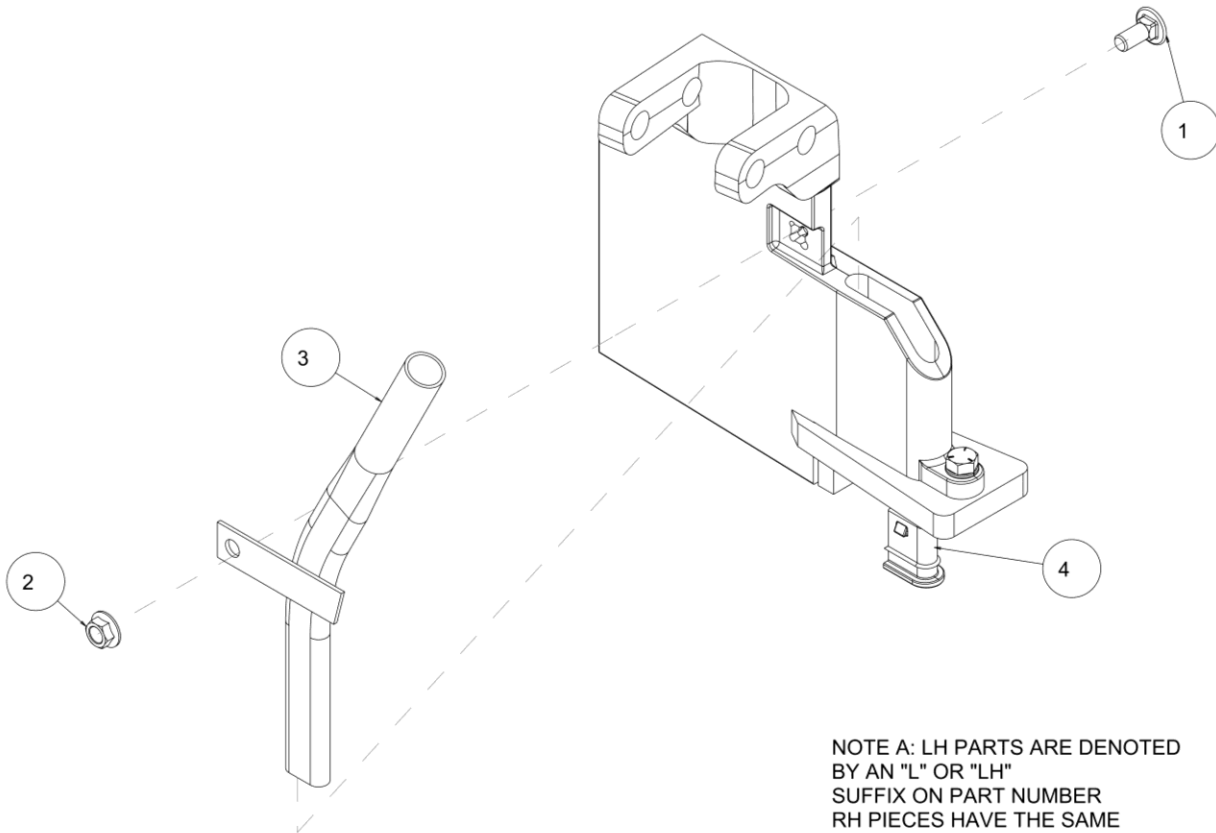

NOTE A: LH PARTS ARE DENOTED  
BY AN "L" OR "LH"  
SUFFIX ON PART NUMBER  
RH PIECES HAVE THE SAME  
NUMBER WITH "R" OR "RH" AS A  
SUFFIX

ITEM	PART #	DESCRIPTION	QTY
1	2505-205	5/16-18 X 3/4 CARBOLT G5 ZP	1
2	2520-206	5/16-18 FLANGE LOCK NUT	1
(A) 3	2987-251-R	RH FERT TUBE W.A. VAPOR ONLY	1
4	2987-414	3/4 PLUG	1

PART IDENTIFICATION

2987-046  
LIQUID (1/2" SINGLE TUBE) KIT

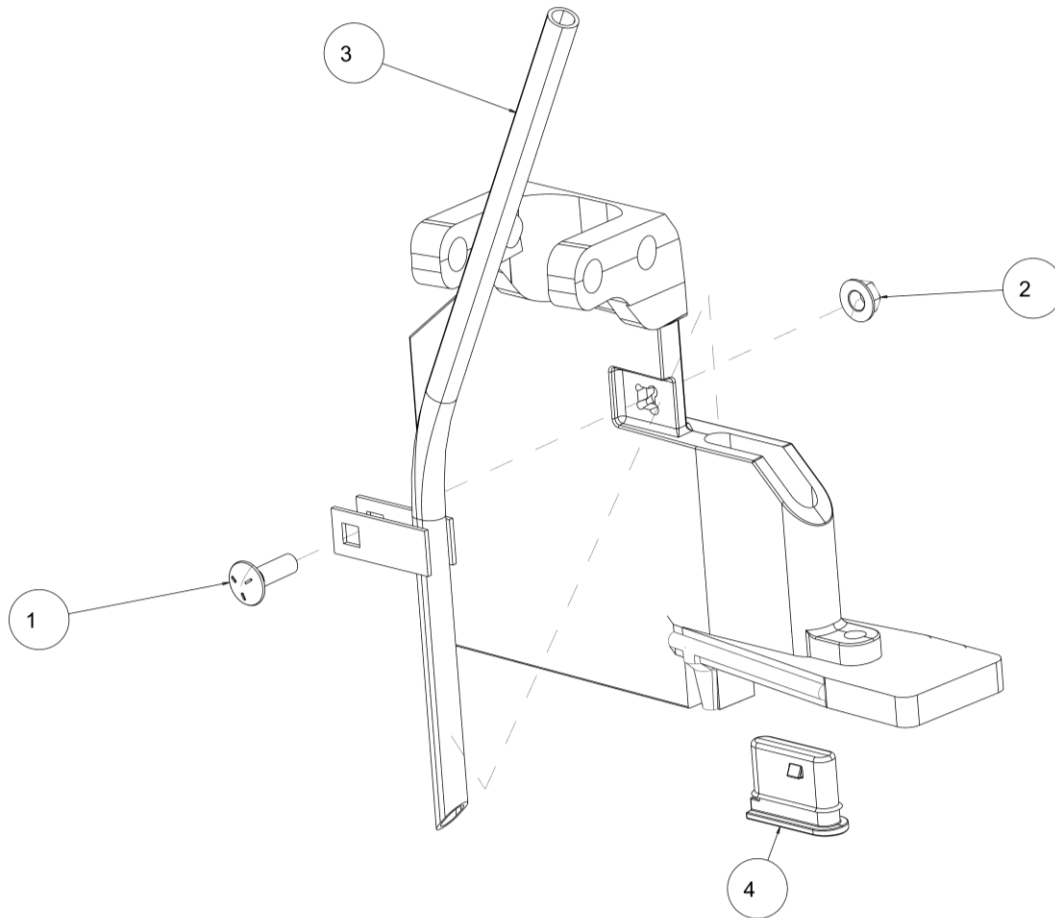

ITEM	PART #	DESCRIPTION	QTY
1	2505-206	5/16-18 X 1 CARBLT GR5 ZP	1
2	2520-206	5/16-18 FLANGE LOCK NUT	1
3	2987-252	1/2" LIQ TUBE W.A.	1
4	2987-412	FULL PLUG	1

# PART IDENTIFICATION

## 2987-047 LIQUID (1/2" DUAL TUBE) KIT

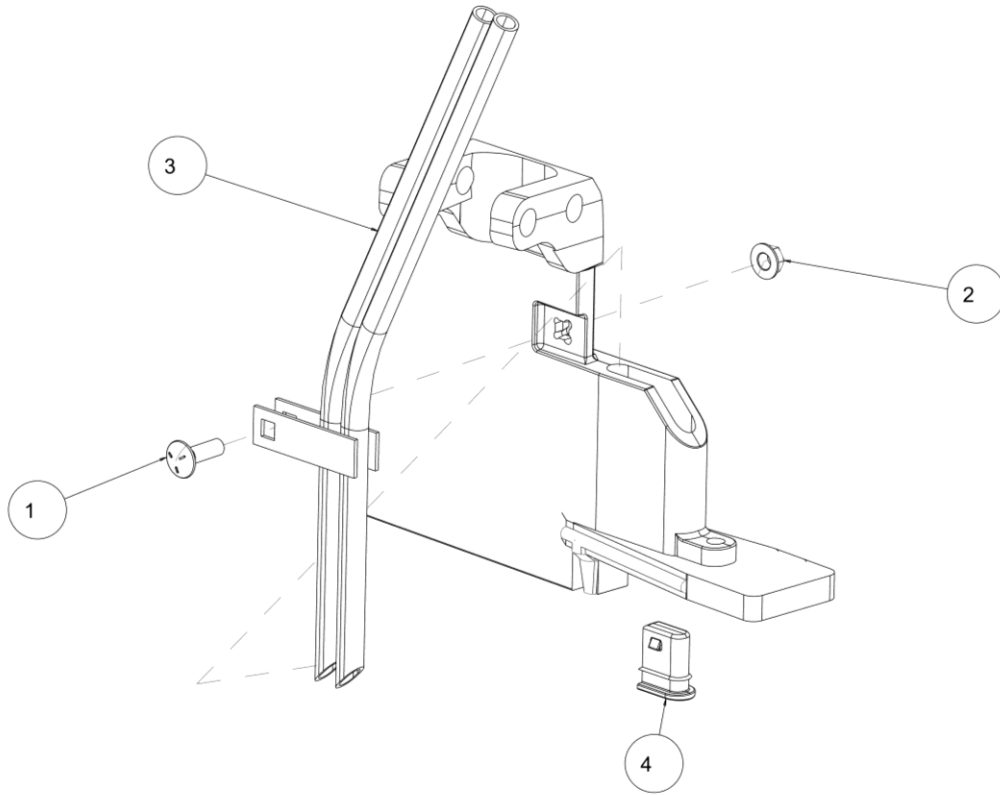

ITEM	PART #	DESCRIPTION	QTY
1	2505-206	5/16-18 X 1 CARBLT GR5 ZP	1
2	2520-206	5/16-18 FLANGE LOCK NUT	1
3	2987-253	1/2" DUAL LIQ TUBE W.A.	1
4	2987-414	3/4 PLUG	1

PART IDENTIFICATION

10000-050-LH (SHOWN) & 10000-050-RH  
MAGNUM GRANULAR FERTILIZER TUBE KIT

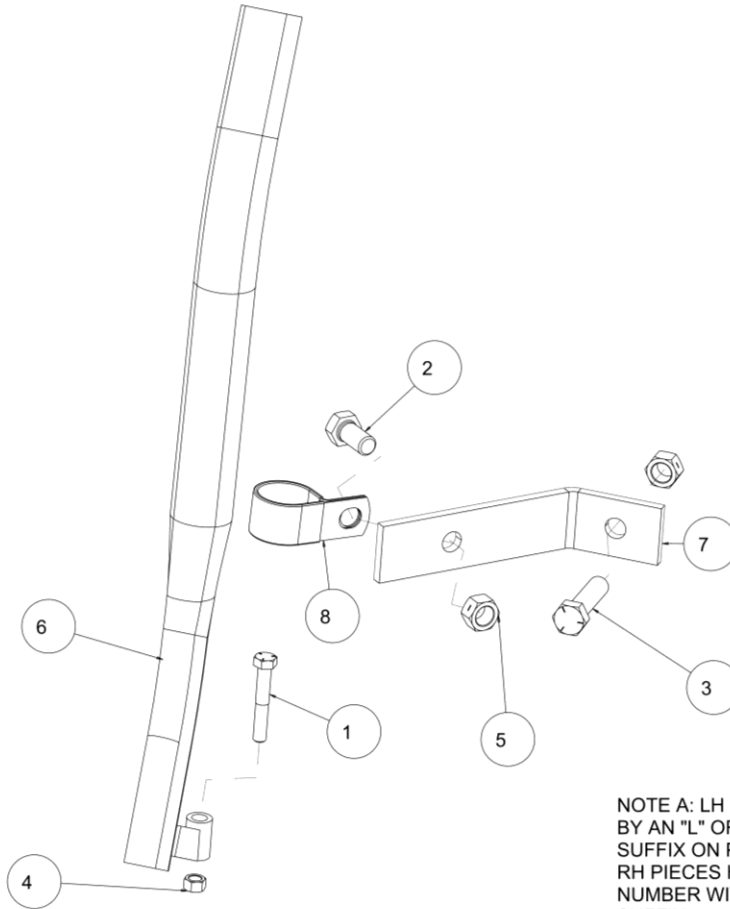

NOTE A: LH PARTS ARE DENOTED BY AN "L" OR "LH" SUFFIX ON PART NUMBER  
RH PIECES HAVE THE SAME NUMBER WITH "R" OR "RH" AS A SUFFIX

ITEM	PART #	DESCRIPTION	QTY
1	2502-207	5/16-18 X 2 HHCS GR5 ZP	1
2	2502-292	1/2-13 X 1 HHCS GR5 YD	1
3	2502-351	1/2-13 X 2 HHCS GR.5 ZP	1
4	2520-201	5/16-18 HEX NUT ZP	1
5	2520-358	1/2-13 LOCK HEX NUT, GR8, ZP	2
(A) 6	10000-206-LH	MAGNUM LH DRY FERT TUBE, W.A.	1
7	10000-345	DRY TUBE SUPPORT	1
8	10000-346	LOOP CLAMP - VINYL CUSHIONED 1.5" I.D.	1

## PART IDENTIFICATION

### 2987-406 RH (TOP) & 2987-407 LH (BOTTOM) MAGNUM KNIFE ATTACHMENT

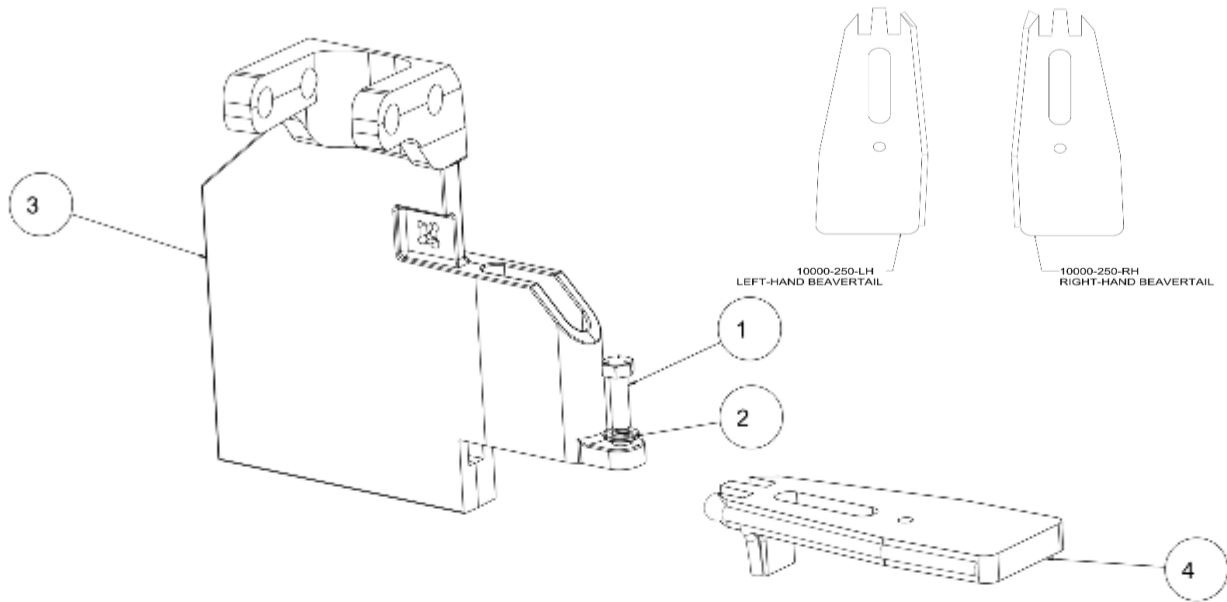

ITEM	PART #	DESCRIPTION	QTY
1	2502-198	5/16-18 X 1 HHCS GR.5 ZP	1
2	2525-201	5/16 MED. LOCKWASHER ZP.	1
3	2987-406-C	SIDE KNIFE w/ CARBIDE RH	1
4	10000-250-RH	BEAVERTAIL RH W.A., 2IN	1

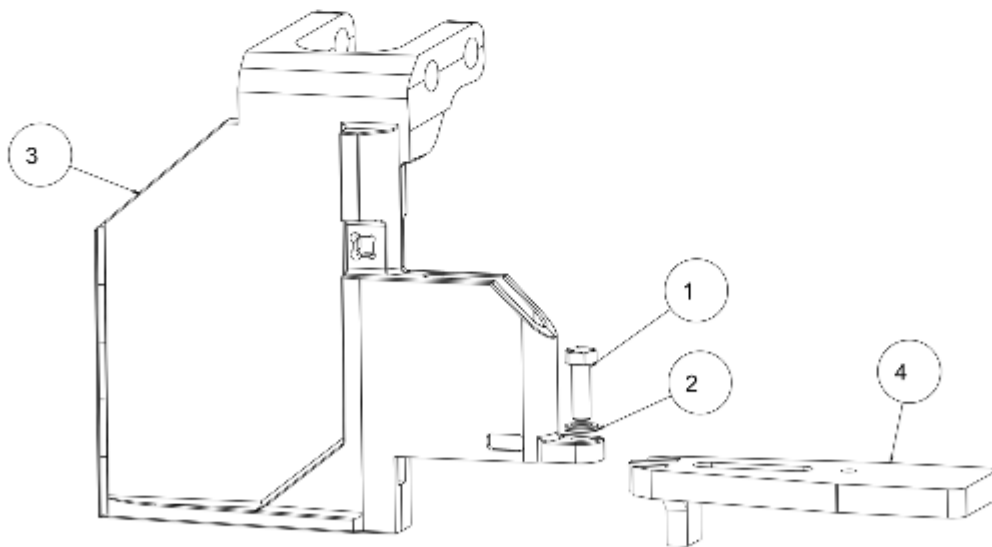

ITEM	PART #	DESCRIPTION	QTY
1	2502-198	5/16-18 X 1 HHCS GR.5 ZP	1
2	2525-201	5/16 MED. LOCKWASHER ZP.	1
3	2987-407-C	SIDE KNIFE w/ CARBIDE LH	1
4	10000-250-LH	BEAVERTAIL LH W.A., 2IN	1



A Tradition of Solutions since 1930

Yetter Farm Equipment Co

PO BOX 358 109 S. McDonough

Colchester, IL 62326-0358

Phone: 309-776-4111

Toll Free: 800-447-5777

Email: [info@yetterco.com](mailto:info@yetterco.com)

For updated models and manuals visit the Yetter website:

[www.yetterco.com](http://www.yetterco.com)

© Yetter Farm Equipment Co. All Rights Reserved

2565-957\_Rev\_M  08/2024