

Yetter

FARM EQUIPMENT

2967-006A RESIDUE MANAGER FOR KINZE UNIT MOUNTED COULTER OPERATOR'S MANUAL

2565-962_REV_D • 08/2023



YETTER MANUFACTURING CO.
FOUNDED 1930

Colchester, IL 62326-0358
Toll free: 800/447-5777
309/776-3222 (Fax)
Website: www.yetterco.com
E-mail: info@yetterco.com

YETTER

FOREWORD

You've just joined an exclusive but rapidly growing club.

For our part, we want to welcome you to the group and thank you for buying a Yetter product.

We hope your new Yetter products will help you achieve both goals-increase your productivity and increase your efficiency so that you may generate more profit.

This operator's manual has been designed into four major sections: Foreword, Safety Precautions, Installation Instructions and Parts Breakdown.



This **SAFETY ALERT SYMBOL** indicates important safety messages in the manual. When you see this symbol, be alert to the possibility of **PERSONAL INJURY** and carefully read the message that follows.

The word **NOTE** is used to convey information that is out of context with the manual text. It contains special information such as specifications, techniques and reference information of a supplementary nature.

The word **IMPORTANT** is used in the text when immediate damage will occur to the machine due to improper technique or operation. Important will

apply to the same information as specified by note only of an immediate and urgent nature.

It is the responsibility of the user to read the operator's manual and comply with the safe and correct operating procedure and to lubricate and maintain the product according to the maintenance schedule in the operator's manual.

The user is responsible for inspecting his machine and for having parts repaired or replaced when continued use of the product would cause damage or excessive wear to the other parts.

It is the user's responsibility to deliver his machine to the Yetter dealer who sold him the product for service or replacement of defective parts, which are covered by the warranty policy.

If you are unable to understand or follow the instructions provided in this publication, consult your local Yetter dealer or contact:

YETTER MANUFACTURING CO.

309/776-4111

800/447-5777

309/776-3222 (FAX)

Website: www.yetterco.com

E-mail: info@yetterco.com

WARRANTY

Yetter Manufacturing warrants all products manufactured and sold by it against defects in material. This warranty being expressly limited to replacement at the factory of such parts or products as shall appear to be defective after inspection. This warranty does not obligate the Company to bear cost of labor in replacement of parts. It is the policy of the Company to make improvements without incurring obligations to add them to any unit already sold. No warranty is made or authorized to be made, other than herein set forth. This warranty is in effect for one year after purchase.

DEALER _____

Yetter Manufacturing warrants its own products only and cannot be responsible for damages to equipment on which mounted.

SAFETY PRECAUTIONS

A brief description of signal words that may be used in this manual:

CAUTION: Used as a general reminder of good safety practices or to direct attention to unsafe practices.

WARNING: Denotes a specific potential hazard.

DANGER: Denotes the most serious specific potential hazard.



CAUTION

Consult your implement and tractor operator's manual for correct and safe operating practices. Be aware of towed implement width and allow safe clearance.



CAUTION: SAFETY SIGNS

Safety decals are placed on the implement to alert the operator and others to the risk of personal injury or unsafe operation during normal operations and servicing.

1. The safety decals must be kept clean and in good condition to ensure that they are legible.
2. Safety decals must be replaced if they are missing or illegible.
3. When components are replaced during repair or servicing, check that the new components include the necessary safety signs.
4. Replacement safety decals may be obtained from your local dealer.



WARNING

Read these instructions carefully to acquaint yourself with the Equipment. Working with unfamiliar equipment can lead to accidents.

Never park the equipment on a steep incline or leave the equipment running unattended.

Never clean, lubricate or adjust a machine that is in motion.

Always check that straps are secure.

Make sure latches are in pinned position when moving equipment.

Do not allow children to operate this equipment.

Do not allow riders on the equipment, trailer and/or pick-up.

Use speed and caution dictated by the terrain being traversed. Do not operate on any slope steep enough to cause tipping or loss of control.

Read and understand the operator's manual and require all other persons who will operate the equipment to do the same.

If operating on public roadways, where legal, be certain all lighting is operating properly and observe all traffic laws.

Beware of increased stopping distances and control effort when operating with implements attached.

Be familiar with all controls and be prepared to stop equipment quickly in an emergency.

FAILURE TO HEED MAY RESULT IN PERSONAL INJURY OR DEATH.

INTRODUCTION

The 2967-006 RESIDUE MANAGER has been designed as a 'universal' fitment for several models of Kinze Unit Mounted Coulters – Planter Models 2000, 3000, 4900.

TABLE OF CONTENTS

Foreword.....	2
Safety.....	3
Torque Specifications.....	4
Image Identifications	5-7
Assembly Instructions	8-15
Operation	16-18
Maintenance	19
Part Identification.....	20-25

BOLT TORQUE





Before operating the 2967-006A Residue Manager for the first time, check to be sure that all hardware is tight. Check all hardware again after approximately 50 hours of operation and at the beginning of each planting season.

All hardware used on the 2967-006A Residue Manager is Grade 5 unless otherwise noted. Grade 5 cap screws are marked with three radial lines on the head. If hardware must be replaced, be sure to replace it with hardware of equal size, strength and thread type. Refer to the torque values chart when tightening hardware.

Important: Over tightening hardware can cause as much damage as when under tightening. Tightening hardware beyond the recommended range can reduce its shock load capacity.

The chart below is a guide for proper torque. Use it unless a specified torque is called out elsewhere in the manual. Torque is the force you apply to the wrench handle or the cheater bar, times the length of the handle or bar. Use a torque wrench whenever possible.

The following table shows torque in ft. lbs. for coarse thread hardware.

Bolt Diameter and Threads per Inch	 Grade 2	 Grade 5	 A-325	 Grade 8
1/4	6	10	14	14
5/16	12	20	30	30
3/8 – 16	25	35	50	50
7/16 – 14	35	55	80	80
1/2 – 13	55	85	125	125
9/16 – 12	75	125	175	175
5/8 – 11	105	170	235	235
3/4-10	185	305	425	425
7/8 – 9	170	445	690	690
1-8	260	670	1030	1030
1 1/8 – 7	365	900	1460	1460
1 1/4 - 7	515	1275	2060	2060
1 3/8 – 6	675	1675	2700	2700
1 1/2 - 6	900	2150	3500	3500
1 3/4 – 5	1410	3500	5600	5600

Lubricate all bearings and moving parts as assembled and make certain that they work freely.



WARNING: Never work around the toolbar/implement while in a raised position without using safety lockups.



CAUTION: The 2967-006A Residue manager attachments are very heavy. Pay extra attention to lifting techniques while handling and or maneuvering the opener during assembly. Failure to do so may lead to personal injury.

IMAGE IDENTIFICATION

2967-006A

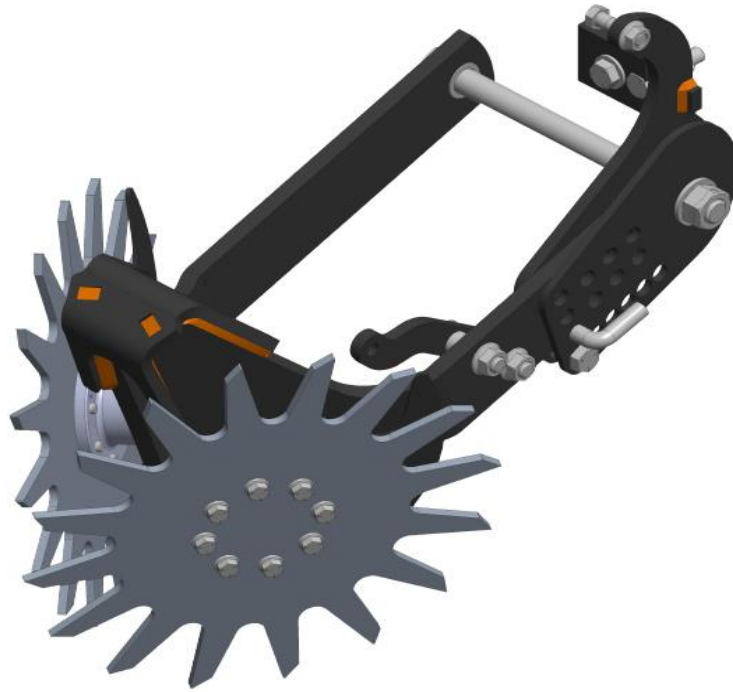

2967-006A-FW



**IMAGE IDENTIFICATION
2967-006A-BW**



2967-006A-BW-FW

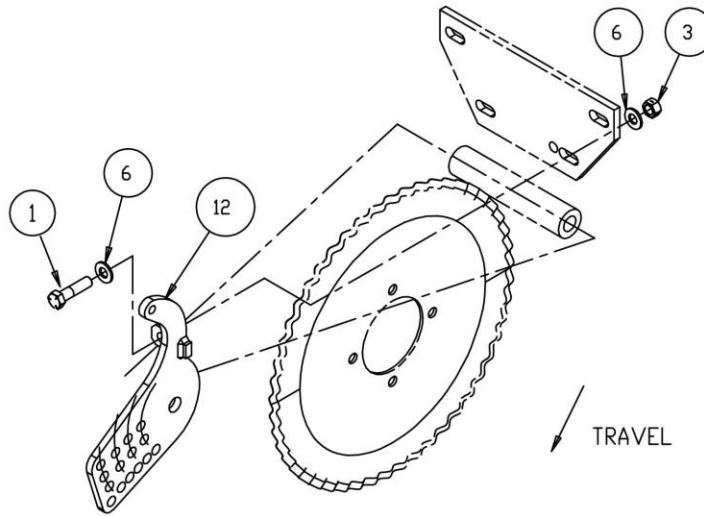

IMAGE IDENTIFICATION
2967-006A-ST-FW



ASSEMBLY INSTRUCTIONS

STEP 1. Remove the bottom left hand bolt from the coultter. Install the 2966-297 mount bracket with the 1/2 X 2" cap screw, 1/2 flat washers and 1/2 locknut.



ITEM	PART NO.	DESCRIPTION
1	2502-351	1/2-13 X 2 HHCS GR.5 ZP
3	2520-357	1/2-13 LOCK HEX NUT, GR A, ZP
6	2526-352	1/2 SAE FLATWASHER ZP
12	2966-297	KINZE MOUNT BRACKET W.A.

ASSEMBLY INSTRUCTIONS

STEP 1A. "CAST IRON COULTER" Remove the bottom left hand bolt from the coultter. Install the 2966-297 mount bracket with the 1/2" X 2-1/4" cap screw, 1/2" flat washers, 2966-298 adapter and 1/2" locknut.

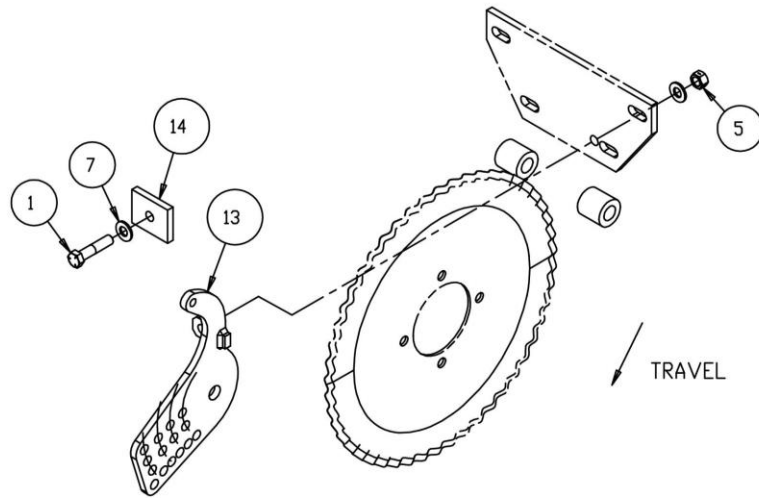

ITEM	PART NO.	DESCRIPTION
1	2502-314	1/2-13 X 2-1/4" GRADE 5 HHCS ZP
5	2520-357	1/2-13 LOCK HEX NUT, GR A, ZP
7	2526-352	1/2 SAE FLATWASHER ZP
13	2966-297	KINZE MOUNT BRACKET W.A.
14	2966-298	ADAPTER SPACER

ASSEMBLY INSTRUCTIONS

STEP 2. Attach the 2966-295 combo arm to the coultter and 2966-297 mount bracket using the 3/4" X 10" cap screw, 3/4" flat washers, 2966-402 bushings, 2966-398 adjustment plate and 3/4" locknut.

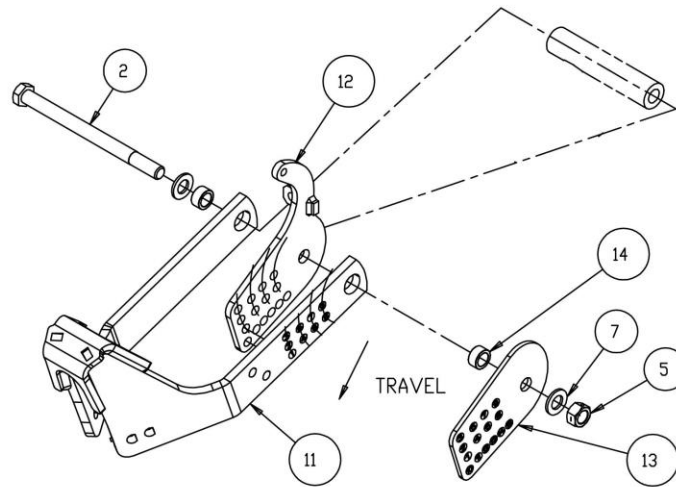

ITEM	PART NO.	DESCRIPTION
2	2502-515	3/4-10 X 10 HHCS GR5 ZP
5	2520-518	3/4-10 LOCK HEX NUT, GR 8, ZP
7	2526-504	3/4 SAE FLATWASHER, ZP
11	2966-295	W.A. ROW CLEANER KINZE COMBO ARM
12	2966-297	KINZE MOUNT BRACKET W.A.
13	2966-398	ADJUSTMENT PLATE
14	2966-402	BUSHING, ZP

ASSEMBLY INSTRUCTIONS

STEP 2A. Attach the 2966-295 combo arm to the coulter and 2966-297 mount bracket using the 3/4" cap screws, 3/4" flat washers, 2966-402 bushings and 2966-398 adjustment plate.

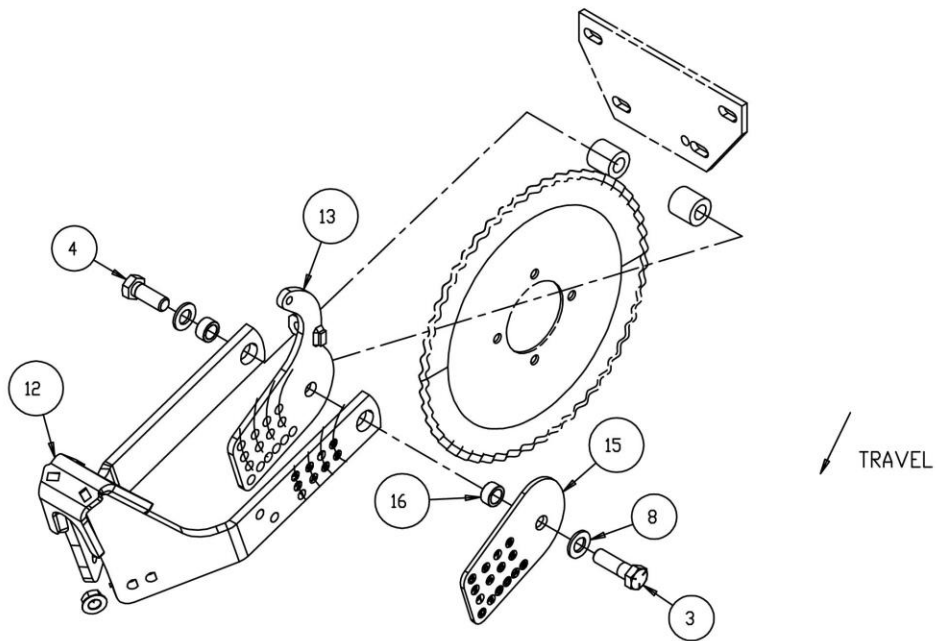

ITEM	PART NO.	DESCRIPTION
3	2502-407	3/4-10 X 2-1/2 HHCS GR5 ZP
4	2502-503	3/4-10 X 2 HHCS GR.5 ZP
8	2526-504	3/4 SAE FLATWASHER, ZP
12	2966-295	W.A. ROW CLEANER KINZE COMBO ARM
13	2966-297	KINZE MOUNT BRACKET W.A.
15	2966-398	ADJUSTMENT PLATE
16	2966-402	BUSHING, ZP

ASSEMBLY INSTRUCTIONS

STEP 3. Attach 2966-398 adjustment plate to the 2966-297 mount bracket using the 1/2" x 2" cap screw and 1/2" locknut. DO NOT FULLY TIGHTEN UNTIL STEP 4.

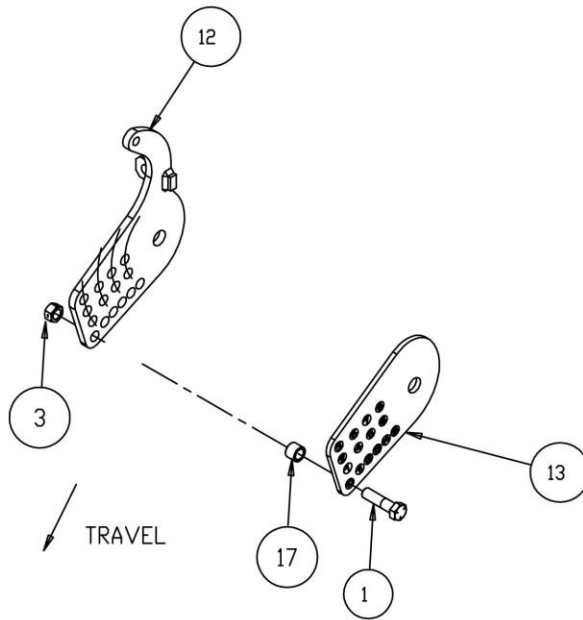

ITEM	PART NO.	DESCRIPTION
1	2502-351	1/2-13 X 2 HHCS GR.5 ZP
3	2520-357	1/2-13 LOCK HEX NUT, GR A, ZP
12	2966-297	KINZE MOUNT BRACKET W.A.
13	2966-398	ADJUSTMENT PLATE
17	2967-622	9/16" SPACER ZP

ASSEMBLY INSTRUCTIONS

STEP 4. Install the 2984-326 pin to align the adjustment holes of the 2966-295 combo arm, 2966-297 mount bracket and 2966-398 adjustment plate. **NOW FULLY TIGHTEN THE 1/2" X 2" cap screw to secure the 2966-398 adjustment plate in position.**

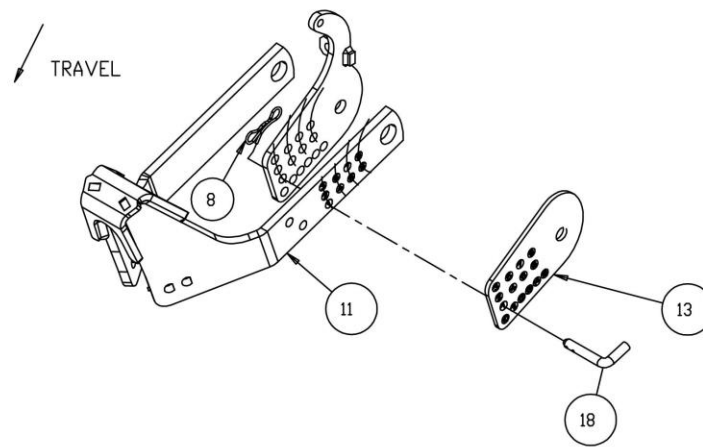

ITEM	PART NO.	DESCRIPTION
8	2570-448	.120BOWTIE LCKING COTT ZP
11	2966-295	W.A. ROW CLEANER KINZE COMBO ARM
12	2966-297	KINZE MOUNT BRACKET W.A.
13	2966-398	ADJUSTMENT PLATE
18	2984-326	R.M. UPSTOP PIN ZP

ASSEMBLY INSTRUCTIONS

STEP 5. Attach the left hand, right hand wheel assemblies and scrapers to the combo arm. Secure with the 5/8 flange lock hex nuts. Torque 180 ft. lbs.

ITEM	PART NO.	DESCRIPTION
4	2520-464	5/8-11 WHIZLOCK HEX NUT, GR 2, ZP
9	2966-140-ST-FW	SHRKTH ASSY,RH,3"D-BOLT FLT WL
10	2966-141-ST-FW	SHRKTH ASSY,LH,3"D-BOLT FLT WL
11	2966-295	W.A. ROW CLEANER KINZE COMBO ARM
15	2967-331-L	SCRAPER, LH
16	2967-331-R	SCRAPER, RH

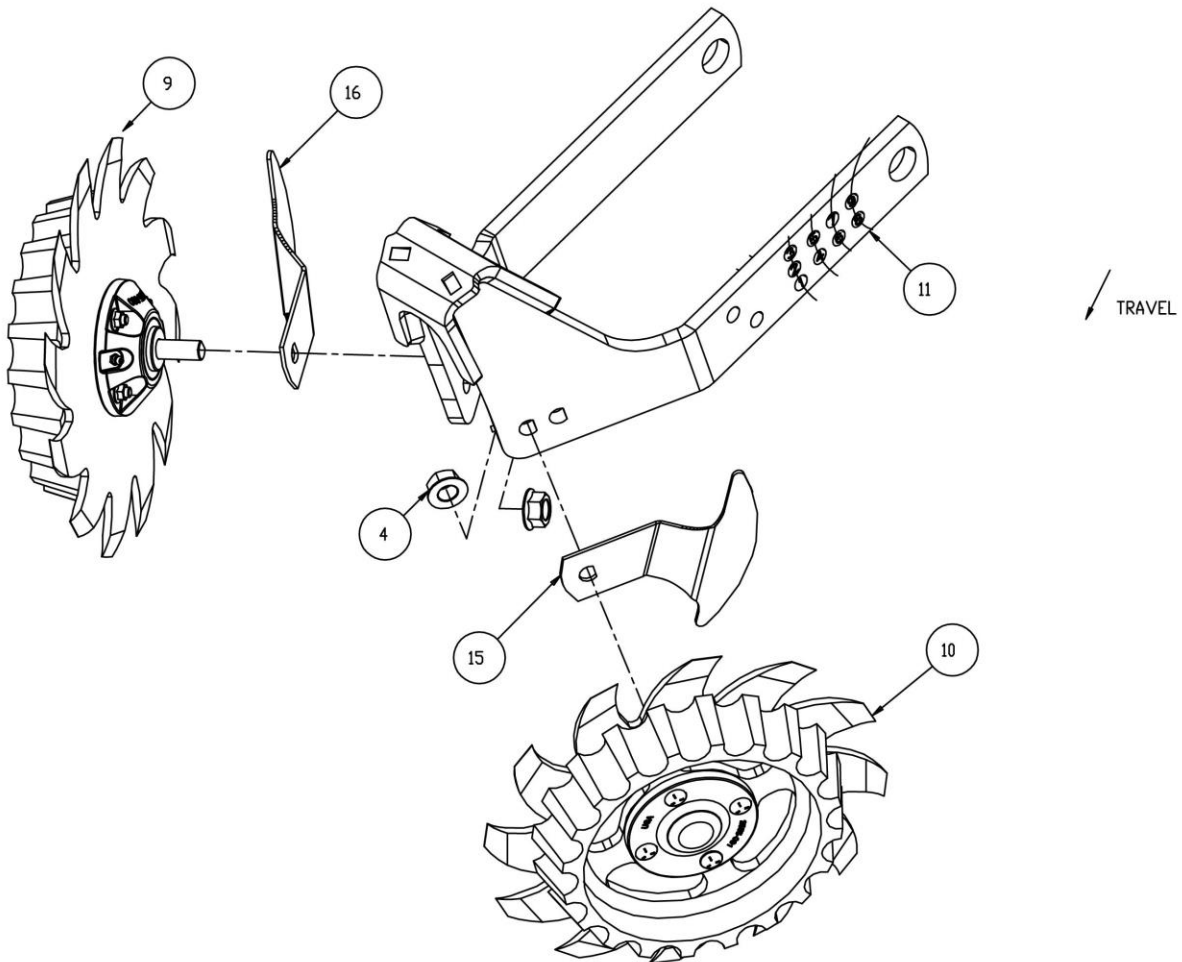

ASSEMBLY INSTRUCTIONS

STEP 6. OPTIONAL: Attach the 2966-405 cylinder anchor to the 2966-295 combo arm using the 1/2" carriage bolts, spacers and 1/2" flange lock nuts. Attach the air cylinder to the 2966-297 mount bracket using the 7/16" X 1-1/2" cap screw and 7/16" flange lock nut.

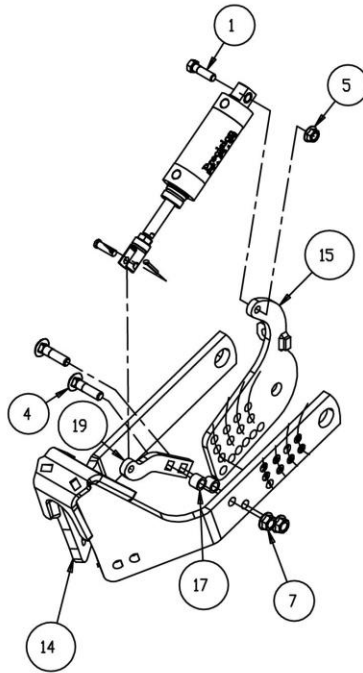

ITEM	PART NO.	DESCRIPTION
1	2502-266	7/16-14 X 1-1/2 HHCS GR 5 ZP
4	2505-345	1/2-13 X 2 CAR BLT GR5 ZP
5	2520-307	7/16-14 FLANGE LOCK NUT
7	2520-361	1/2-13 FLANGE WHZLCK HXNT, GR 5, ZP
14	2966-295	W.A. ROW CLEANER KINZE COMBO ARM
15	2966-297	KINZE MOUNT BRACKET W.A.
17	2966-401	SPACER, ZP
19	2966-405	CYLINDER ARM ANCHOR

OPERATION PRECAUTIONS

STOP

Read this before using the Yetter product.

- MACHINE OPERATION

IMPORTANT: failure to properly set the planter frame height and levelness can result in less than successful operation of the planter and the Yetter product and may result in damaged equipment. All operators should read and thoroughly understand the instructions given prior to using the Yetter product.

NOTE: **DO NOT** use this product if the planter is not adjusted properly!

Leveling the planter:

With the planter lowered to proper operating height (**Usually 20"-22"**).

Read the planter operator's manual for recommended setting. Check to be sure the toolbar and row unit parallel arms are level fore and aft. **Re-check** when the planter is in the **field** and has been **fully loaded** with seed, fertilizer, granular chemicals, etc. Also, a field check with a bubble level on the frame should be made of the hitch height to ensure level operation front to back.

It is important for the planter to operate level laterally. Tire pressure must be maintained at pressures specified by the manufacturer.

Field and actual planting conditions change and will dictate planter frame heights. You must ensure that the row unit parallel arms are approximately parallel with the ground.

IMPORTANT: For proper operation of the planter attachments and row units, it is imperative that the planter toolbars and row unit parallel arms be level side-to-side and front-to-rear. The toolbar frame should operate at a 20"-22" height from the **planting surface**. Check the manufacturer's operator's manual for instructions on how to adjust the frame height and levelness.

PLANTER HEIGHT ADJUSTMENT

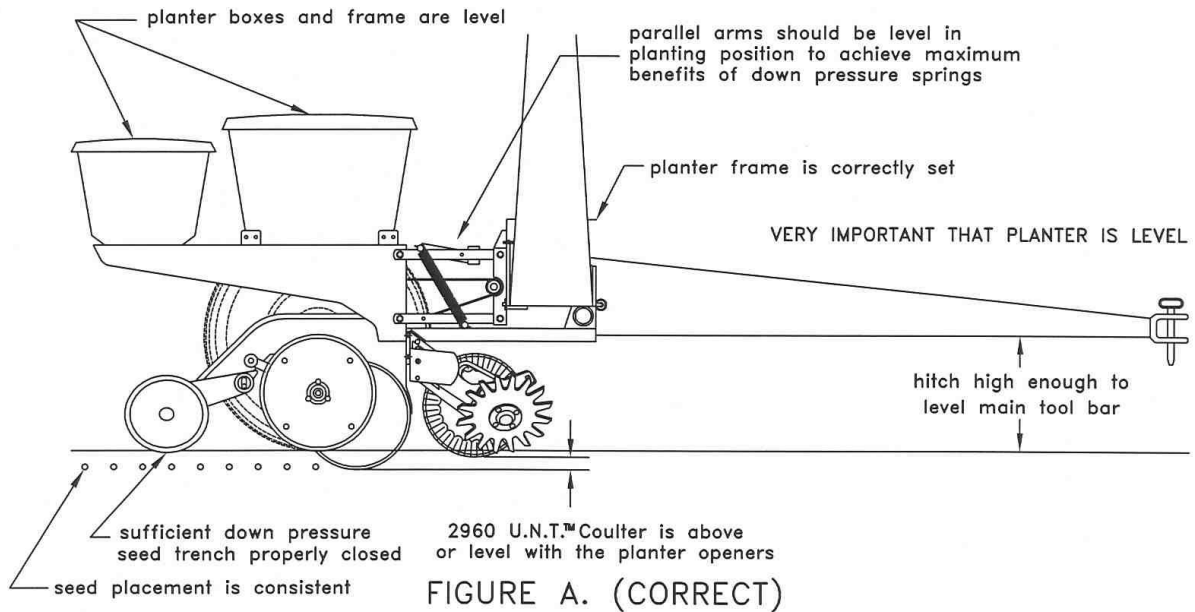

1720-19

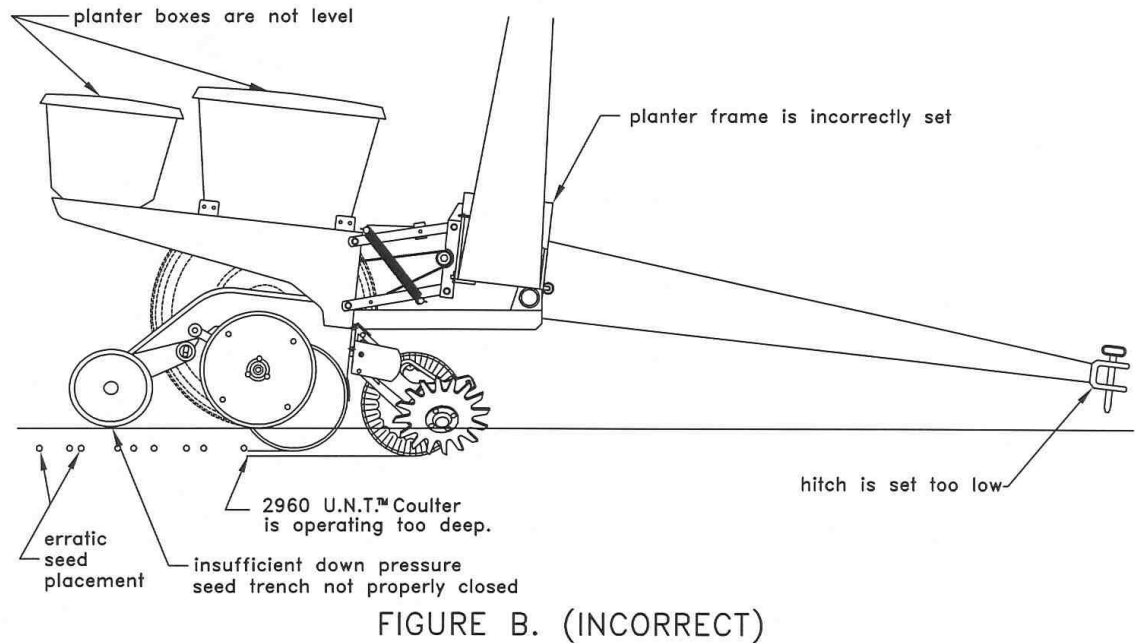

Figure A. – The planter hitch and frame are both 20” off the ground. To ensure this, visually check to see that the planter boxes are level and that the planter unit parallel arms are also parallel with the ground. **When using planter attachments located in front of the planter unit, this setting is very important.**

Figure B. – The planter hitch is set too low while the planter frame remains at 20” off the ground! Notice from the illustration that the unit mounted coulter is running deeper in the ground than the planter unit. This condition can result in the formation of an air pocket below the seedbed, which will in turn dramatically decrease seed growth.

NOTE: Both illustrations are strictly for reference only. They are intended to show that proper adjustment of the hitch height is critical. Consult your planter operator’s manual for the proper height adjustment of the hitch.

OPERATION



CAUTION: Where rocks are present the residue manager should be set in the “float” position, not locked down.

Adjust the residue manager to move crop residue aside and not move any soil. Adjustments to the residue manager may have to be made when changing field conditions and type and amount of residue.

- Float setting – install the adjustment pin under the residue manager arm.
- Rigid setting – install the adjustment pin through the residue arm.

ROW CLEANER DO'S AND DON'TS

1. **DO NOT** move soil; Residue Managers are designed to move crop residue only.
2. **DO NOT** operate planter at slow speeds, ground speed affects how aggressive the spoke wheels are; operate at sufficient speed (4-6 mph) to maintain good residue flow.
3. **DO NOT** expect 100% of crop residue to be cleared, it is not necessary and would necessitate engaging the soil. The width of path cleared depends on ground conditions, depth setting and ground speed.
4. **DO** expect to see wheels occasionally quit turning, indicates ideal (shallow) setting which is not moving soil.
5. **DO** adjust toolbar frame height 20”-22” and drawbar correctly. Very important to ensure planter opener will follow ground contours properly.



IMPORTANT: For proper operation, the planter frame must operate level (for, aft and side to side) and at the correct height, typically 20”-22”. Regularly inspect the residue manager for loose or worn bolts. Repair and replace as needed.

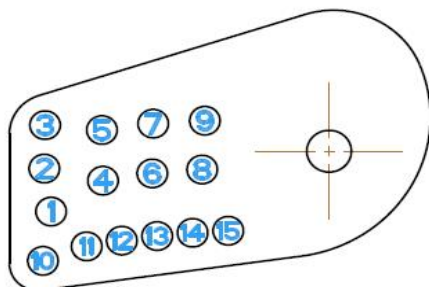

1/4" DEPTH ADJUSTMENTS
PINNED: #1-9 (0"-2")
FLOATING: #10-15 (0"-1.25")
NOTE: #10 FOR BUSHING ONLY

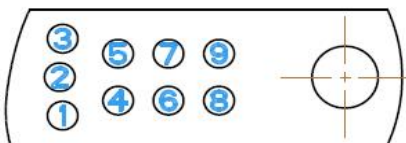

MAINTENANCE

Practice Safety

Understand and practice safe service procedures before doing work. Follow ALL the operating, maintenance and safety information in the equipment operator manual. Clear the area of bystanders, especially small children, when performing any maintenance or adjustments. Keep work area clean and dry. Use adequate lighting for the job. Use only tools, jacks and hoists of sufficient capacity for the job.

Never lubricate, service, or adjust machine while it is moving. Keep hands, feet, and clothing from power-driven moving and rotating parts. Disengage all power and operate controls to relieve pressure. Lower equipment to the ground and stop the engine. Remove the key. Wait for all moving parts to stop before servicing, adjusting, repairing or unplugging.

Securely support any machine elements with blocks or safety stands that must be raised for service work.

Keep all parts in good condition and properly installed. Fix damaged equipment immediately. Replace worn or broken parts. Remove any buildup of grease, oil, or debris.

Make sure all guards are in place and properly secured when maintenance work is completed.



CAUTION: To help prevent serious injury or death to you or others caused by unexpected movement, service machine on a level surface. Lower machine to ground or sufficiently lock or block raised machine before servicing. If machine is connected to tractor, engage parking brake and place transmission in "PARK", shut off engine and remove key. If machine is detached from tractor, block wheels and use shop stands to prevent movement.

Storing the Equipment

Store the machine in an area away from human activity

Store machine in RAISED position.

Install service locks on all wheel cylinders.

At the end of the season, the machine should be thoroughly inspected and prepared for storage. Repair or replace any worn or damaged components to prevent down time at the start of the next season. Store machine under cover with all parts in operating condition.

- Clean machine thoroughly to remove all dirt, debris, and crop residue, which would hold moisture and cause rusting.
- Inspect machine for worn or broken parts. See your Yetter Farm Equipment dealer during the off-season so that parts or service can be acquired when machine is not needed in the field.
- Lubricate bearings as outlined in the Lubrication section
- Paint all parts which are chipped or worn and require repainting.
- Store machine in a clean, dry place with the planting unit out of the sun.
- If the machine cannot be stored inside, cover with a waterproof tarpaulin and tie securely in place.
- Do not allow children to play on or around the machine

PART IDENTIFICATION

2967-006A-ST-FW

KINZE WELDED COULTER (NOT INCLUDED)

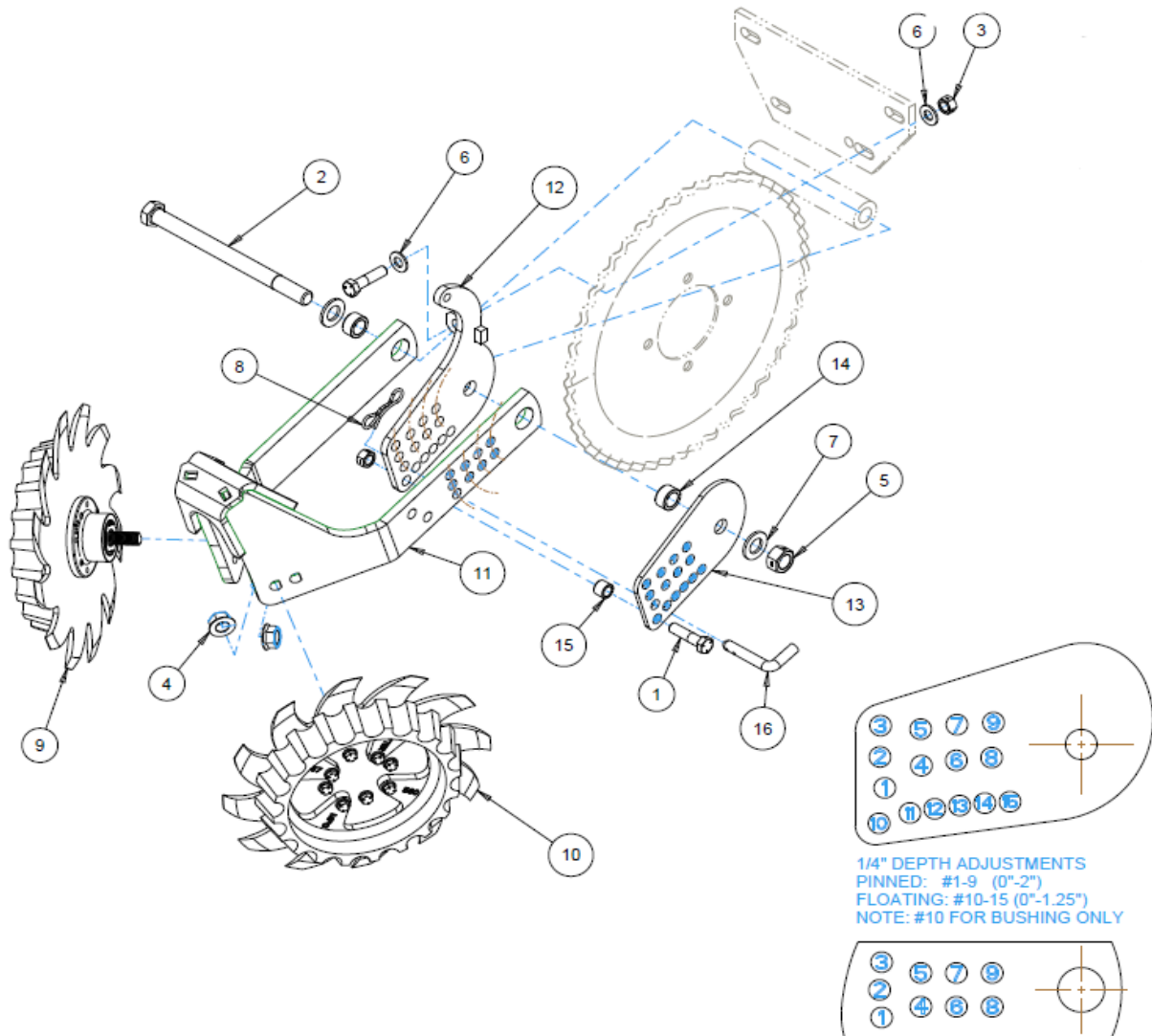

ITEM	PART NO.	DESCRIPTION	QTY
1	2502-351	1/2-13 X 2 HHCS GR.5 ZP	2
2	2502-515	3/4-10 X 10 HHCS GR5 ZP	1
3	2520-357	1/2-13 LOCK HEX NUT, GR A, ZP	2
4	2520-465	5/8-11 SER. FLANGE NUT, GR 8, ZP	2
5	2520-518	3/4-10 LOCK HEX NUT, GR 8, ZP	1
6	2526-352	1/2 SAE FLATWASHER ZP	2
7	2526-504	3/4 SAE FLATWASHER, ZP	2
8	2570-448	.120 BOWTIE LOCKING COTTER ZP	1
9	2966-140-ST-FW	SHRKTH ASSY,RH,3"D-BOLT FLT WL	1
10	2966-141-ST-FW	SHRKTH ASSY,LH,3"D-BOLT FLT WL	1
11	2966-295	W.A. ROW CLEANER KINZE COMBO ARM	1
12	2966-297	KINZE MOUNT BRACKET W.A.	1
13	2966-398	ADJUSTMENT PLATE	1
14	2966-402	BUSHING, ZP	2
15	2967-622	9/16" SPACER ZP	1
16	2984-326	R.M. UPSTOP PIN ZP	1

PART IDENTIFICATION

2967-006A-ST-FW

KINZE CAST COULTER (NOT INCLUDED)

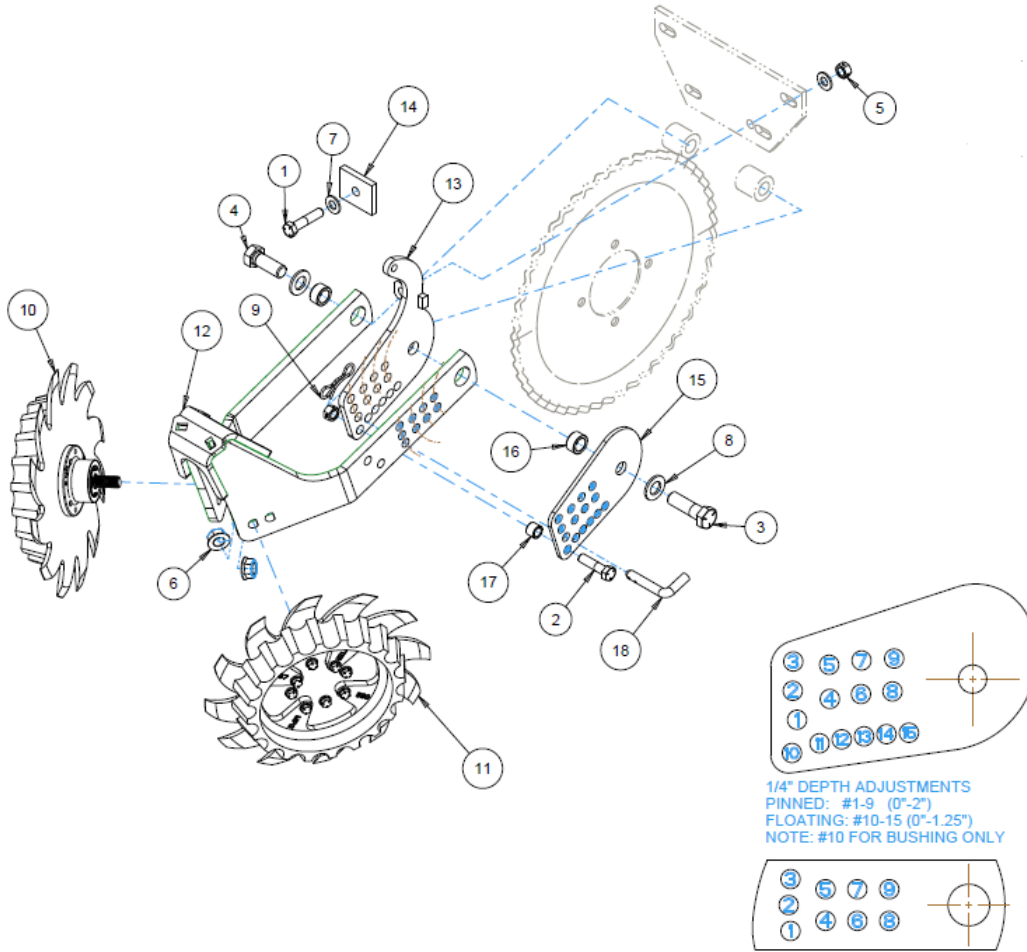

ITEM	PART NO.	DESCRIPTION	QTY
1	2502-314	1/2-13 X 2-1/4" GRADE 5 HHCS ZP	1
2	2502-351	1/2-13 X 2 HHCS GR.5 ZP	1
3	2502-407	3/4-10 X 2-1/2 HHCS GR5 ZP	1
4	2502-503	3/4-10 X 2 HHCS GR.5 ZP	1
5	2520-357	1/2-13 LOCK HEX NUT, GR A, ZP	2
6	2520-465	5/8-11 SER. FLANGE NUT, GR 8, ZP	2
7	2526-352	1/2 SAE FLATWASHER ZP	2
8	2526-504	3/4 SAE FLATWASHER, ZP	2
9	2570-448	.120 BOWTIE LOCKING COTTER ZP	1
10	2966-140-ST-FW	SHRKTH ASSY,RH,3"D-BOLT FLT WL	1
11	2966-141-ST-FW	SHRKTH ASSY,LH,3"D-BOLT FLT WL	1
12	2966-295	W.A. ROW CLEANER KINZE COMBO ARM	1
13	2966-297	KINZE MOUNT BRACKET W.A.	1
14	2966-298	ADAPTER SPACER	1
15	2966-398	ADJUSTMENT PLATE	1
16	2966-402	BUSHING, ZP	2
17	2967-622	9/16" SPACER ZP	1
18	2984-326	R.M. UPSTOP PIN ZP	1

PART IDENTIFICATION

2967-006A-ST-FW

KINZE WELDED COULTER (NOT INCLUDED)
PRECISION CLEAN SWEEP AIR CYLINDER (NOT INCLUDED)

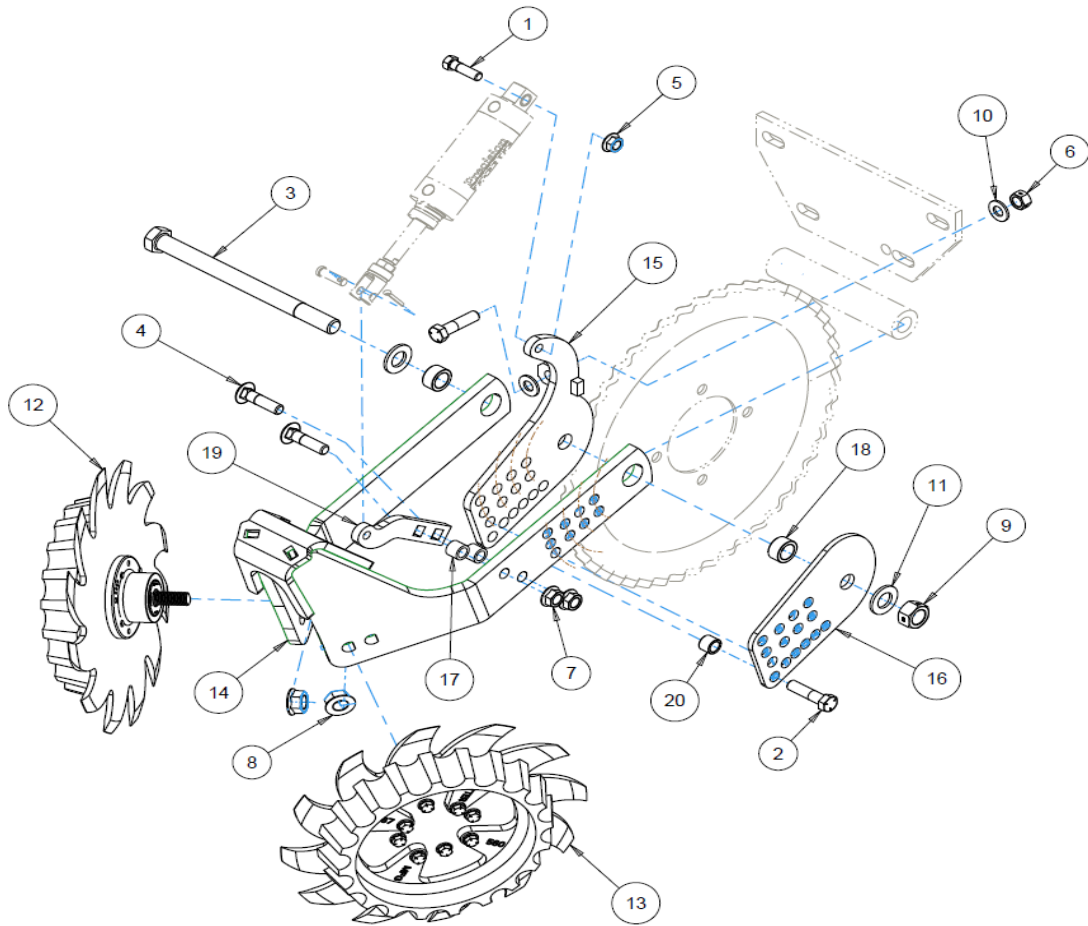

ITEM	PART NO.	DESCRIPTION	QTY
1	2502-266	7/16-14 X 1-1/2 HHCS GR 5 ZP	1
2	2502-351	1/2-13 X 2 HHCS GR.5 ZP	2
3	2502-515	3/4-10 X 10 HHCS GR5 ZP	1
4	2505-345	1/2-13 X 2 CAR BLT GR5 ZP	2
5	2520-307	7/16-14 FLANGE LOCK NUT	1
6	2520-357	1/2-13 LOCK HEX NUT, GR A, ZP	2
7	2520-361	1/2-13 FLANGE WHZLCK HXNT, GR 5, ZP	2
8	2520-465	5/8-11 SER. FLANGE NUT, GR 8, ZP	2
9	2520-518	3/4-10 LOCK HEX NUT, GR 8, ZP	1
10	2526-352	1/2 SAE FLATWASHER ZP	2
11	2526-504	3/4 SAE FLATWASHER, ZP	2
12	2966-140-ST-FW	SHRKTH ASSY,RH,3"D-BOLT FLT WL	1
13	2966-141-ST-FW	SHRKTH ASSY,LH,3"D-BOLT FLT WL	1
14	2966-295	W.A. ROW CLEANER KINZE COMBO ARM	1
15	2966-297	KINZE MOUNT BRACKET W.A.	1
16	2966-398	ADJUSTMENT PLATE	1
17	2966-401	SPACER, ZP	2
18	2966-402	BUSHING, ZP	2
19	2966-405	CYLINDER ARM ANCHOR	1
20	2967-622	9/16" SPACER ZP	1

PART IDENTIFICATION

2967-006A-ST-FW

KINZE CAST COULTER (NOT INCLUDED)
PRECISION CLEAN SWEEP AIR CYLINDER (NOT INCLUDED)

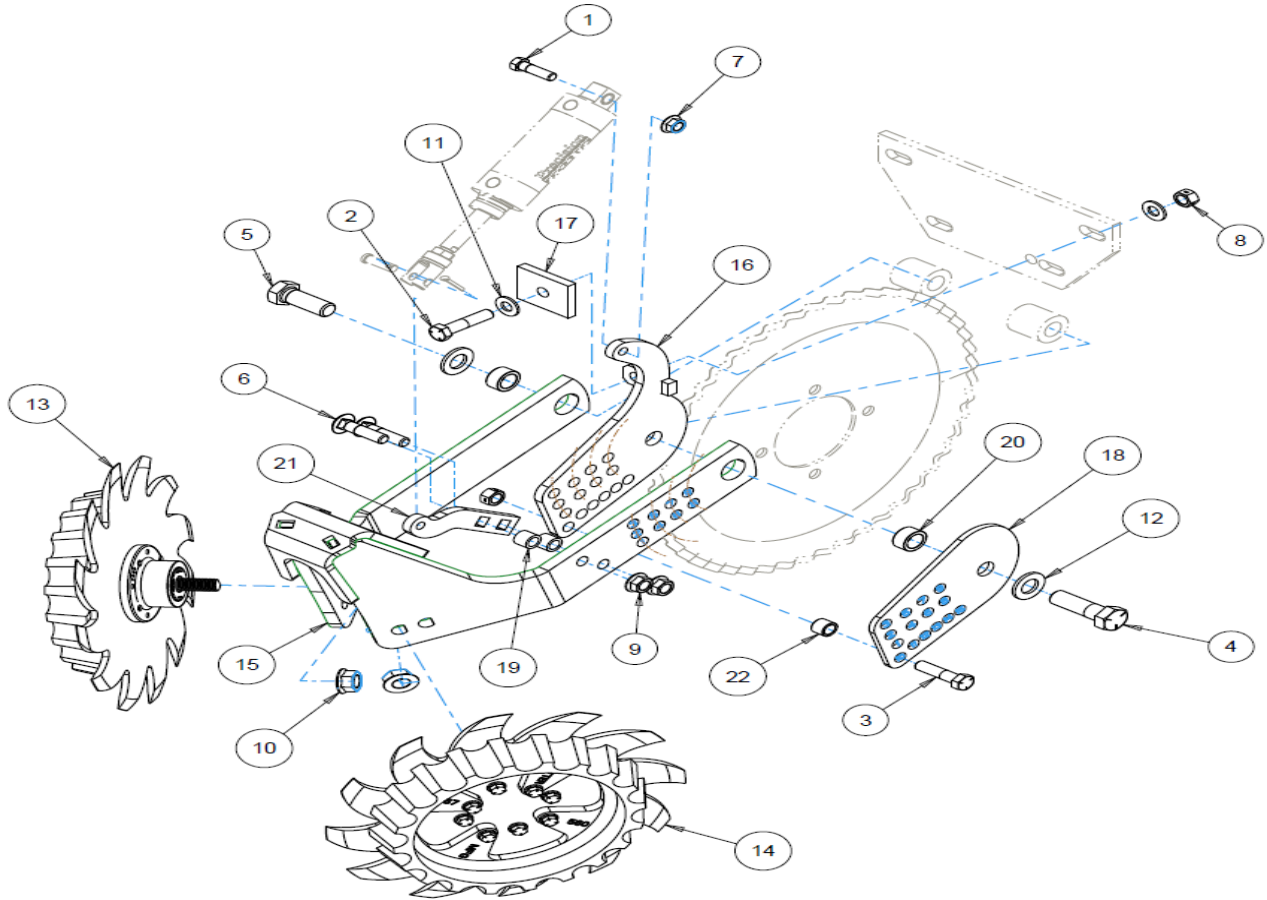

ITEM	PART NO.	DESCRIPTION	QTY
1	2502-266	7/16-14 X 1-1/2 HHCS GR 5 ZP	1
2	2502-314	1/2-13 X 2-1/4" GRADE 5 HHCS ZP	1
3	2502-351	1/2-13 X 2 HHCS GR.5 ZP	1
4	2502-407	3/4-10 X 2-1/2 HHCS GR5 ZP	1
5	2502-503	3/4-10 X 2 HHCS GR.5 ZP	1
6	2505-345	1/2-13 X 2 CAR BLT GR5 ZP	2
7	2520-307	7/16-14 FLANGE LOCK NUT	1
8	2520-357	1/2-13 LOCK HEX NUT, GR A, ZP	2
9	2520-361	1/2-13 FLANGE WHZLCK HXNT, GR 5, ZP	2
10	2520-465	5/8-11 SER. FLANGE NUT, GR 8, ZP	2
11	2526-352	1/2 SAE FLATWASHER ZP	2
12	2526-504	3/4 SAE FLATWASHER, ZP	2
13	2966-140-ST-FW	SHRKTH ASSY,RH,3"D-BOLT FLT WL	1
14	2966-141-ST-FW	SHRKTH ASSY,LH,3"D-BOLT FLT WL	1
15	2966-295	W.A. ROW CLEANER KINZE COMBO ARM	1
16	2966-297	KINZE MOUNT BRACKET W.A.	1
17	2966-298	ADAPTER SPACER	1
18	2966-398	ADJUSTMENT PLATE	1
19	2966-401	SPACER, ZP	2
20	2966-402	BUSHING, ZP	2
21	2966-405	CYLINDER ARM ANCHOR	1
22	2967-622	9/16" SPACER ZP	1

PART IDENTIFICATION

2966-140-ST-FW

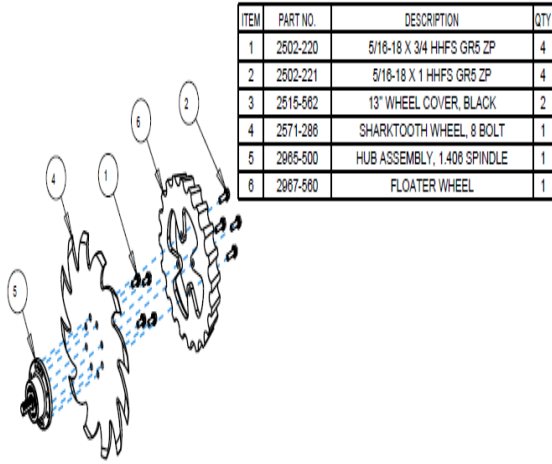

2966-140-ST-PFW

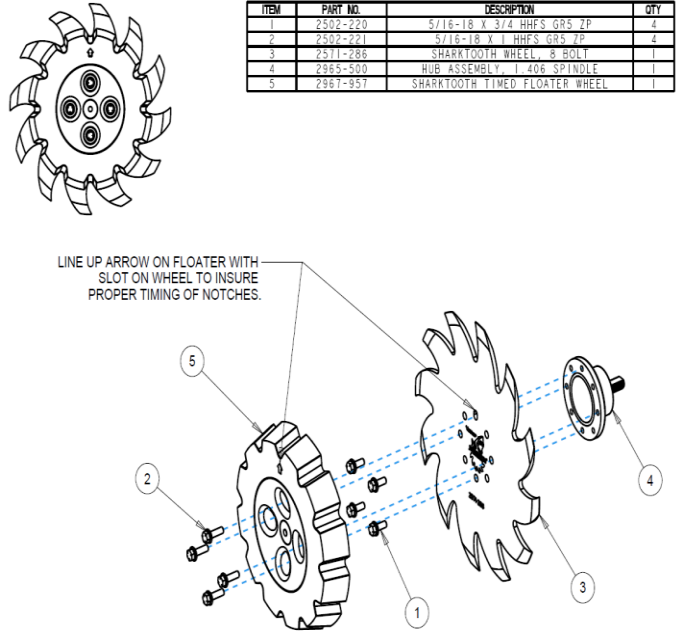

2966-140-BW-FW

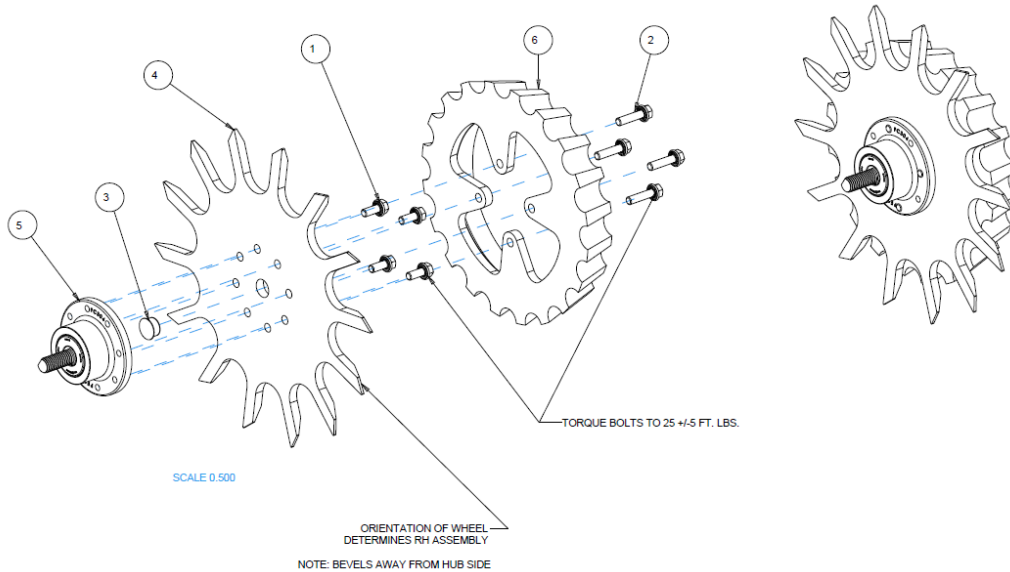

ITEM	PART NO.	DESCRIPTION	QTY
1	2502-220	5/16-18 X 3/4 HHFS GR5 ZP	4
2	2502-222	5/16-18 X 1-1/4 HHFS GR5 ZP	4
3	2570-994	BEVEL WHEEL CENTER HOLE PLUG	1
4	2571-287-R	13" BEVEL WHEEL, 8 BOLT, RH	1
5	2965-500	HUB ASSEMBLY, 1.406 SPINDLE	1
6	2967-560	FLOATER WHEEL	1

PART IDENTIFICATION

2966-140-STF-FW

RIGHT HAND SHARKTOOTH FINGER WHEEL ASSEMBLY

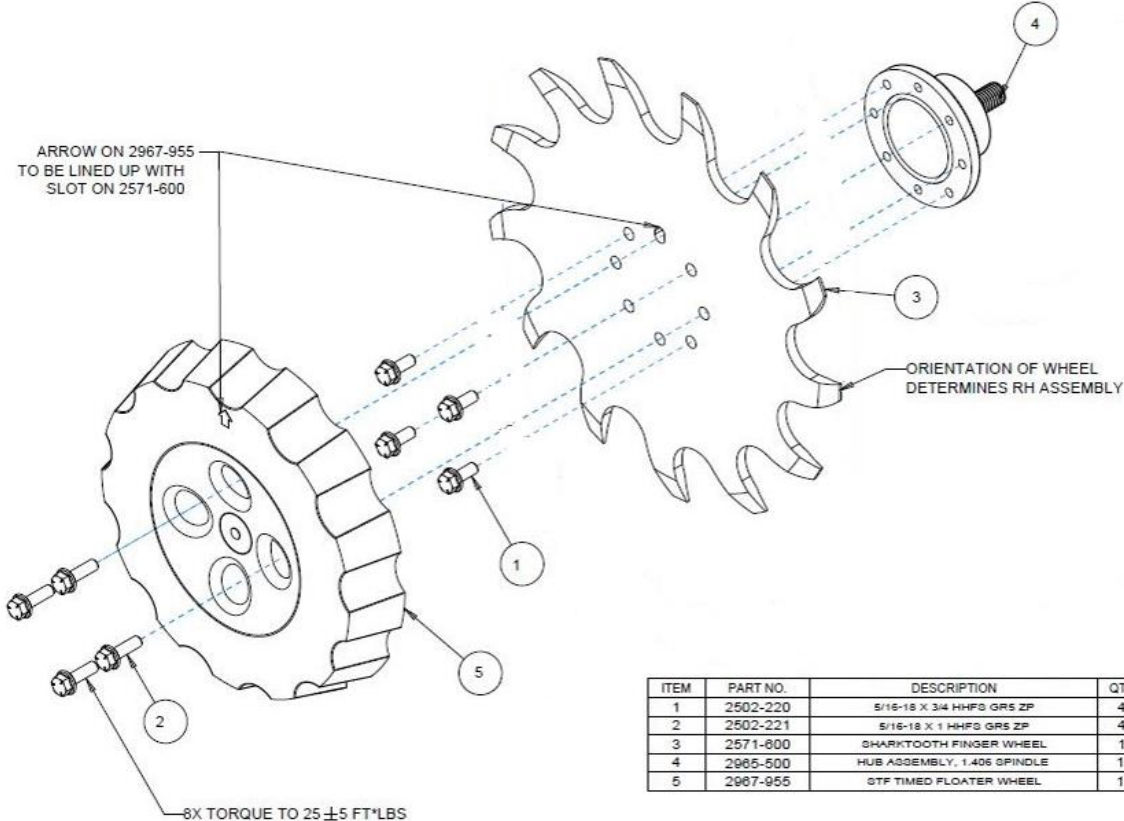

2966-141-FW TAPER TOOTH WHEEL ASSEMBLY

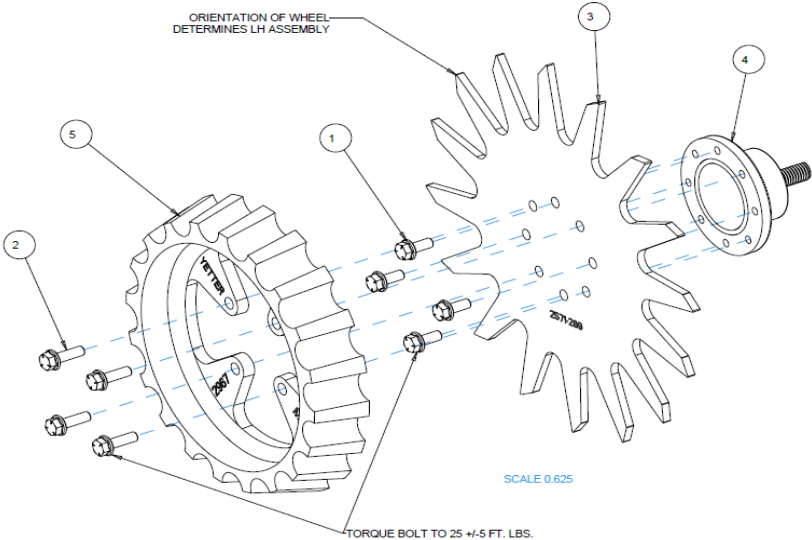

ITEM	PART NO.	DESCRIPTION	QTY
1	2502-220	5/16-18 X 3/4 HHFS GR5 ZP	4
2	2502-221	5/16-18 X 1 HHFS GR5 ZP	4
3	2571-289	13" TAPER TOOTH SPOKE WHEEL, 8 BOLT	1
4	2965-500	HUB ASSEMBLY, 1.406 SPINDLE	1
5	2967-560	FLOATER WHEEL	1

FIELD SERVICE KITS

- 2965-119 - SERVICE KIT FOR 2570-740-2.812 D-BOLT
- 2965-120 - SERVICE KIT FOR 2570-742-3.812 D-BOLT
- 2965-121 - SERVICE KIT FOR 2570-766-2.562 D-BOLT

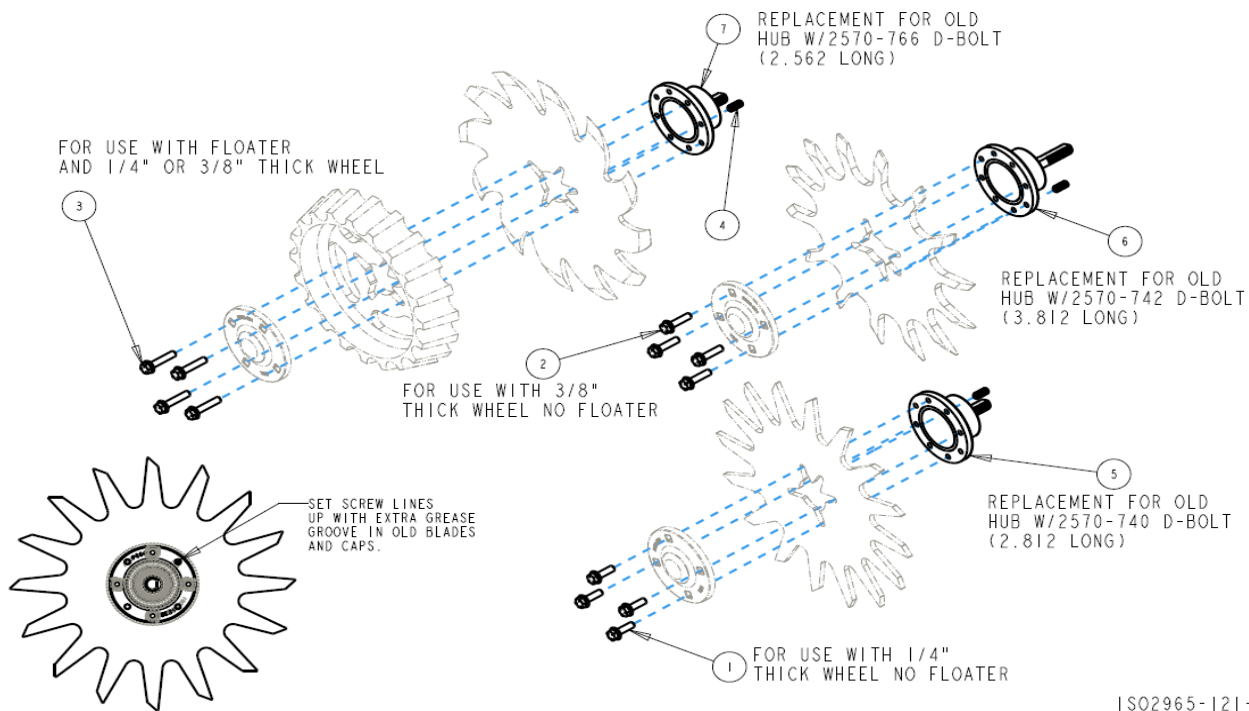

ISO2965-121-2

ITEM	PART NO	DESCRIPTION	QTY
1	2502-221	5/16-18 X 1 HHFS GRADE 5	4
2	2502-222	5/16-18 X 1-1/4 HHFS GRADE 5	4
3	2502-225	5/16-18 X 1-1/2 HHFS GRADE 5	4
4	2940-560	SET SCREW	1
5	2965-500	HUB ASSEMBLY 1.406 SPINDLE	1
6	2965-501	HUB ASSEMBLY 2.406 SPINDLE	1
7	2965-502	HUB ASSEMBLY 1.157 SPINDLE	1



ITEM	PART NO	DESCRIPTION	QTY
1	2505-207	5/16-18 X 1-1/4 CARRIAGE HEAD BOLT GRADE 5	4
2	2520-206	5/16-18 FLANGE LOCK NUT	4
3	2570-740	D-BOLT FLANGE HEAD 5/8-11 X 2.812 GRADE 8	1
4	2965-128	HUB/BEARING ASSEMBLY	1
	2550-069	SEAL	1
	2570-594	BEARING	1
	2570-715	INSERT	1
	2965-351	HUB	1
	2533-110	GREASE FITTING	1
5	2965-352	HUB CAP	1
6	2967-602	SHARK TOOTH WHEEL	1
7	2520-465	5/8-11 FLANGE LOCK NUT GRADE 8	1

NOTES



A Tradition of Solutions since 1930

Yetter Farm Equipment Co

PO BOX 358 109 S. McDonough

Colchester, IL 62326-0358

Phone: 309-776-4111

Toll Free: 800-447-5777

Email: info@yetterco.com

For updated models and manuals visit the Yetter website:

www.yetterco.com

© Yetter Farm Equipment Co. All Rights Reserved

2565-962_REV_D • 08/2023