



OWNER'S MANUAL  
PART IDENTIFICATION  
2565-989 REV E 2/2024  
**Furrow Max**

**6200-070, 6200-071, 6200-072, 6200-073, 6200-080**



**YETTER MANUFACTURING CO.**

Founded 1930

Colchester, IL 62326

Toll free: (800)447-5777.

Fax: (309)776-3222

Website: [yetterco.com](http://yetterco.com)

E-mail: [info@yetterco.com](mailto:info@yetterco.com)

**YETTER**

# TABLE OF CONTENTS

**BOLT TORQUE..... 2**  
**FOREWORD..... 3**  
**SAFETY..... 4**  
**INSTALLATION..... 5-13**  
**OPERATION..... 14**  
**PARTS IDENTIFICATION.....15-36**



## BOLT TORQUE





**Important:** Over-tightening hardware can cause just as much damage as under-tightening. Tightening hardware beyond the recommended range can reduce its shock load capacity.

All hardware is either Grade 5 unless otherwise noted. Grade 5 cap screws are marked with three radial lines on the head. Grade 8 cap screws are marked with six radial lines on the head. If hardware must be replaced, be sure to replace it with hardware of equal size, strength and thread type. Refer to the torque values chart when tightening hardware.

The chart below is a guide for proper torque. Use it unless a specified torque is called out elsewhere in the manual. Torque is the force applied to the end of the handle or cheater bar, times the length of the handle or bar. Tightening hardware beyond the recommended range can reduce its shock load capacity.

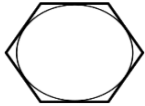
### Use a torque wrench wherever possible

The following table shows torque in ft.-lbs. for coarse thread hardware.

Bolt Diameter and Threads per Inch	 Grade 2	 Grade 5	 A-325	 Grade 8
1/4	6	10		14
5/16	12	20		30
3/8 – 16	25	35		50
7/16 – 14	35	55		80
1/2 – 13	55	85		125
9/16 – 12	75	125		175
5/8 – 11	105	170		235
3/4-10	185	305		425
7/8 – 9	170	445		690
1-8	260	670		1030
1 1/8 – 7	365	900		1460
1 1/4 - 7	515	1275		2060
1 3/8 –6	675	1675		2700
1 1/2 - 6	900	2150		3500
1 3/4 – 5	1410	3500		5600

## FOREWORD

You've just joined an exclusive but rapidly growing club.

For our part, we want to welcome you to the group and thank you for buying a Yetter product.

We hope your new Yetter products will help you achieve both goals-increase your productivity and increase your efficiency so that you may generate more profit.

This operator's manual has been designed into four major sections: Foreword, Safety Precautions, Installation Instructions and Parts Breakdown.



This **SAFETY ALERT SYMBOL** indicates important safety messages in the manual. When you see this symbol, be alert to the possibility of **PERSONAL INJURY** and carefully read the message that follows.

The word **NOTE** is used to convey information that is out of context with the manual text. It contains special information such as specifications, techniques and reference information of a supplementary nature.

The word **IMPORTANT** is used in the text when immediate damage will occur to the machine due to improper technique or operation.

Important will apply to the same information as specified by note only of an immediate and urgent nature.

It is the responsibility of the user to read the operator's manual and comply with the safe and correct operating procedure and to lubricate and maintain the product according to the maintenance schedule in the operator's manual.

The user is responsible for inspecting his machine and for having parts repaired or replaced when continued use of the product would cause damage or excessive wear to the other parts.

It is the user's responsibility to deliver his machine to the Yetter dealer who sold him the product for service or replacement of defective parts, which are covered by the warranty policy.

If you are unable to understand or follow the instructions provided in this publication, consult your local Yetter dealer or contact:

### **YETTER MANUFACTURING CO.**

309/776-4111

800/447-5777

309/776-3222 (FAX)

Website: [www.yetterco.com](http://www.yetterco.com)

E-mail: [info@yetterco.com](mailto:info@yetterco.com)

## WARRANTY

Yetter Manufacturing warrants all products manufactured and sold by it against defects in material. This warranty being expressly limited to replacement at the factory of such parts or products as shall appear to be defective after inspection. This warranty does not obligate the Company to bear cost of labor in replacement of parts. It is the policy of the Company to make improvements without incurring obligations to add them to any unit already sold. No warranty is made or authorized to be made, other than herein set forth. This warranty is in effect for one year after purchase.

DEALER: \_\_\_\_\_

**Yetter Manufacturing warrants its own products only and cannot be responsible for damages to equipment on which mounted.**

# BE ALERT!

## YOUR SAFETY IS INVOLVED



**WATCH FOR THIS SYMBOL. IT POINTS OUT IMPORTANT SAFETY PRECAUTIONS. IT MEANS “ATTENTION – BE ALERT!”**

It is your responsibility as an owner, operator, or supervision to know and instruct everyone using this machine at the time of initial assignment and at least annually thereafter, of the proper operation, precautions, and work hazards which exist in the operation of the machine in accordance with OSHA regulations.

### Safety Is No Accident



**The following safety instructions, combined with common sense, will save your equipment from needless damage and the operator from unnecessary exposure to personal hazard. Pay special attention to the caution notes in the text. Review this manual at least once a year with all operators.**

1. Read and understand the operator's manual before operating this machine. Failure to do so is considered a misuse of the equipment.
2. Make sure equipment is secure before operating.
3. Always keep children away from equipment when operating.
4. Make sure everyone that is not directly involved with the operation is out of the work area before beginning operation.
5. Make sure all safety devices, shields, and guards are in place and functional before beginning operation
6. Shut off all power to adjust, service, or clean.
7. Keep hands, feet, and clothing away from moving parts. It is a good idea to remove all jewelry before operating.
8. Inspect the machine periodically during operation for signs of excessive wear, loose fasteners, and unusual noises.

# INSTALLATION INSTRUCTIONS John Deere

## 7200/7300/1700 6200-070

### STEP 1:

Remove the closing wheel arm, spring and pivot bolts. Then take off the cast block bolted to the row unit. Save the two 12MM bolts holding it on.

### STEP 2:

Using the two 12MM bolts, attach the furrow max unit to the row unit. Ensure that the closing system is straight with the row unit and torque the bolts to 92 ft/lbs.

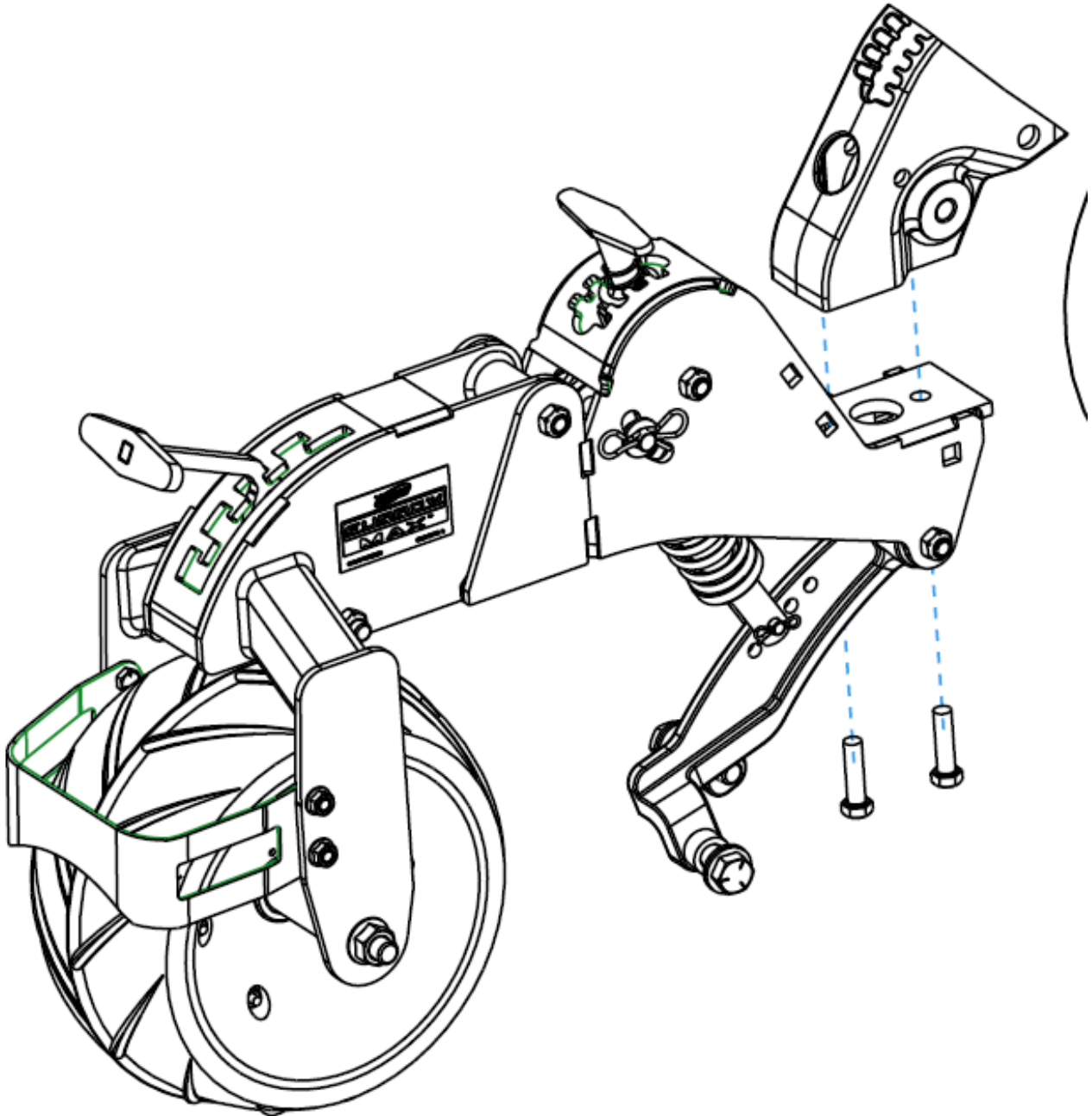

# INSTALLATION INSTRUCTIONS

## STEP 3:

Use the 1/2" x 3.75" pin, washers, and cotter pin to attach the spring to the disc pivot bracket. Use the shoulder bolt and locknut to attach the cast closing disc arm to the main body. Use the 3/8" x 1.25" pin and cotter pin to attach the spring to the cast arm in the 3<sup>rd</sup> hole.

Install the 6 x 12" rubber press wheel onto the rear mount using the 5/8 x 10.5" bolt and serrated flange nut, putting a bushing on each side.

Use the 3/8 x .75" bolts to install the mud scraper. It can be adjusted up or down so it is close to the wheel, but not touching.

Attach the closing disc's to the cast arm using the 9/16 spacer between the disc and the arm only. (Additional washers and spacers are for adjusting the disc's wider or narrower)

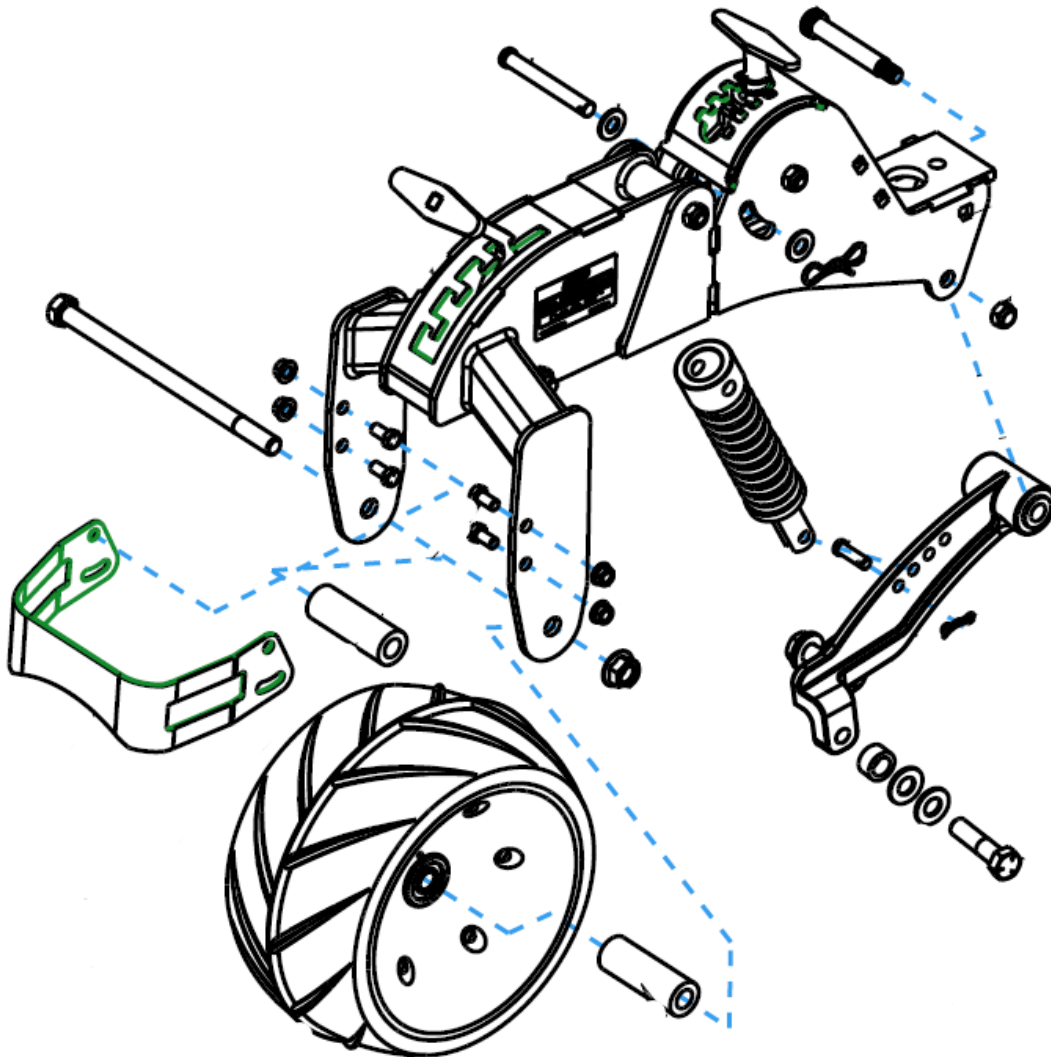

# INSTALLATION INSTRUCTIONS

## John Deere 7200/7300/1700

### 6200-080 V-Closing wheel kit

#### STEP 1:

Remove the closing wheel arm, spring and pivot bolts. Then take off the cast block bolted to the row unit. Save the two 12MM bolts holding it on.

#### STEP 2:

Using the two 12MM bolts, attach the furrow max unit to the row unit. Ensure that the closing system is straight with the row unit and torque the bolts to 92 ft/lbs.

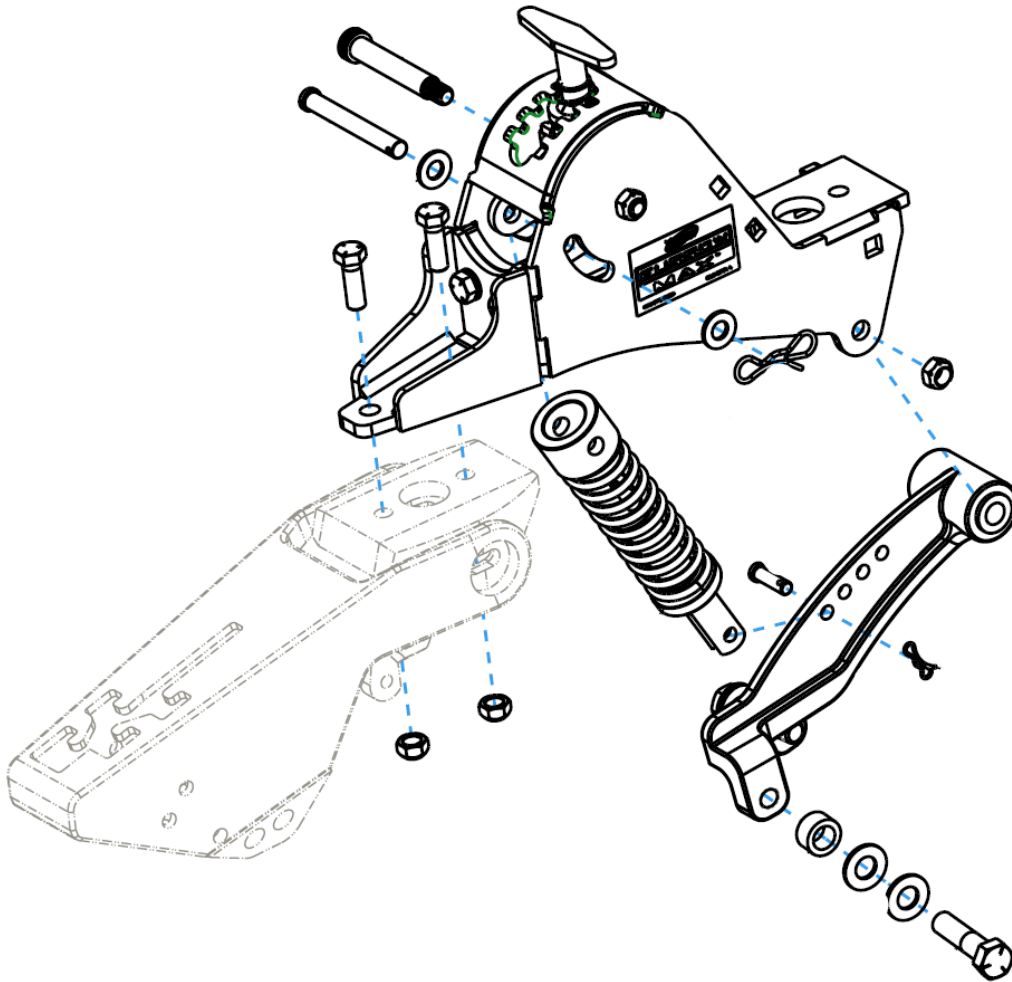

#### STEP 3:

Use the  $\frac{1}{2}$ " x 3.75" pin, washers, and cotter pin to attach the spring to the disc pivot bracket. Use the shoulder bolt and locknut to attach the cast closing disc arm to the main body. Use the  $\frac{3}{8}$ " x 1.25" pin and cotter pin to attach the spring to the cast arm in the 3<sup>rd</sup> hole.

Attach the stock cast closing arm mount block with the two  $\frac{1}{2}$ " x 1.5" bolts and locknuts. Reassemble the closing wheel arm, spring, handle and closing wheels.

# INSTALLATION INSTRUCTIONS

## Kinze 3000 6200-071

### STEP 1:

Remove the closing wheel arm, spring and pivot bolts. Then take off the cast block bolted to the row unit by removing the 3/8" bolt

### STEP 2:

Attach the kinze mount adapter (item 9,10) to the main mount bracket as pictured below. **Leave bolts loose at this time.**

**Note: use the longer 1/2" x 1-1/2" carriage bolts to attach the kinze adapter to the main mount. The shorter 1-1/4" carriage bolts will be used to attach the main mount to the row unit.**

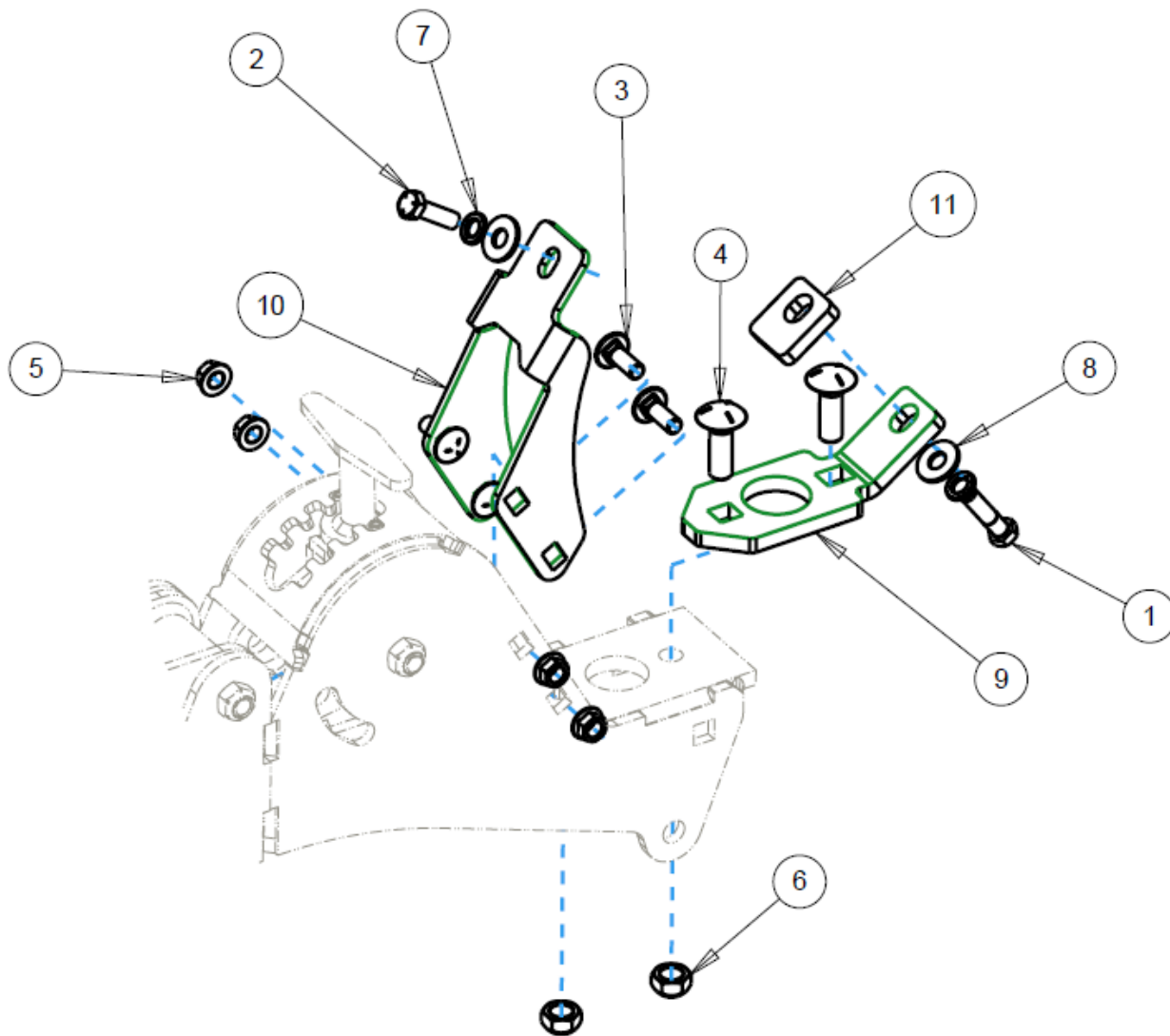



# INSTALLATION INSTRUCTIONS

## STEP 3:

Attach the Furrow Max to the row unit. Make sure all of the bolts are installed before you begin to tighten them.

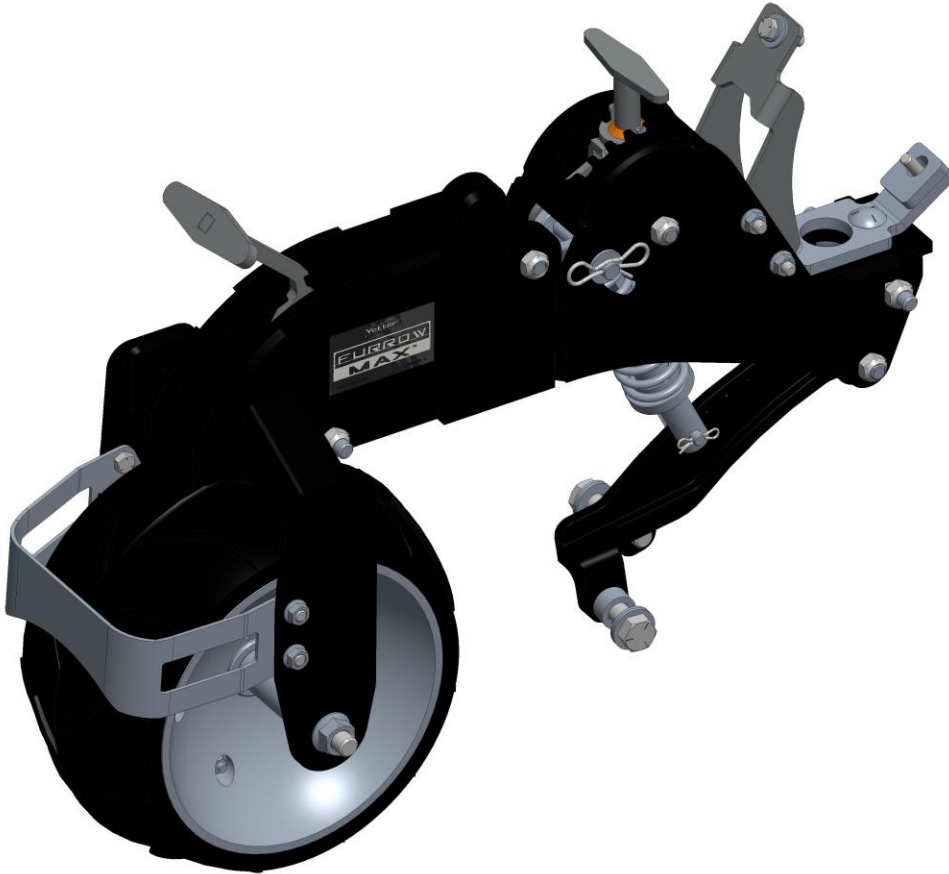

## STEP 4:

Use the  $\frac{1}{2}$ " x 3.75" pin, washers, and cotter pin to attach the spring to the disc pivot bracket. Use the shoulder bolt and locknut to attach the cast closing disc arm to the main body. Use the  $\frac{3}{8}$ " x 1.25" pin and cotter pin to attach the spring to the cast arm in the 3<sup>rd</sup> hole.

Install the 6 x 12" rubber press wheel onto the rear mount using the  $\frac{5}{8}$  x 10.5" bolt and serrated flange nut, putting a bushing on each side.

Use the  $\frac{3}{8}$  x .75" bolts to install the mud scraper. It can be adjusted up or down so it is close to the wheel, but not touching.

Attach the closing disc's to the cast arm using the  $\frac{9}{16}$  spacer between the disc and the arm only. (Additional washers and spacers are for adjusting the disc's wider or narrower)

# INSTALLATION INSTRUCTIONS

## White 9000 6200-072

### STEP 1:

Remove the closing wheel arm, spring and pivot bolts. Then take off the cast block bolted to the row unit. Save the two 12MM bolts holding it on.

### STEP 2:

Using the two 12MM bolts, attach the furrow max unit to the row unit. Ensure that the closing system is straight with the row unit and torque the bolts to 92 ft/lbs.

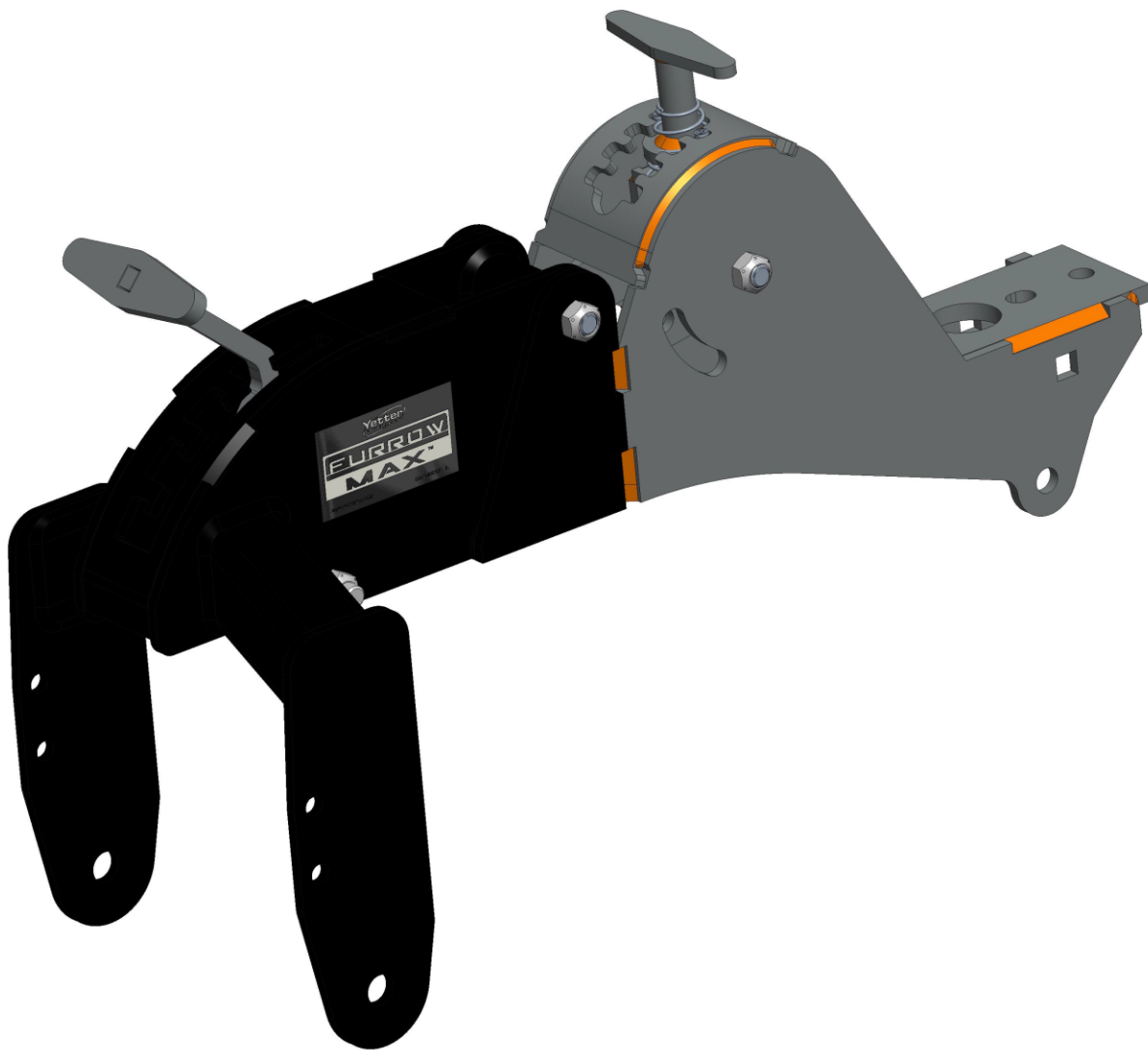

# INSTALLATION INSTRUCTIONS

## STEP 3:

Use the 1/2" x 3.75" pin, washers, and cotter pin to attach the spring to the disc pivot bracket. Use the shoulder bolt and locknut to attach the cast closing disc arm to the main body. Use the 3/8" x 1.25" pin and cotter pin to attach the spring to the cast arm in the 3<sup>rd</sup> hole.

Install the 6 x 12" rubber press wheel onto the rear mount using the 5/8 x 10.5" bolt and serrated flange nut, putting a bushing on each side.

Use the 3/8 x .75" bolts to install the mud scraper. It can be adjusted up or down so it is close to the wheel, but not touching.

Attach the closing disc's to the cast arm using the 9/16 spacer between the disc and the arm only. (Additional washers and spacers are for adjusting the disc's wider or narrower)

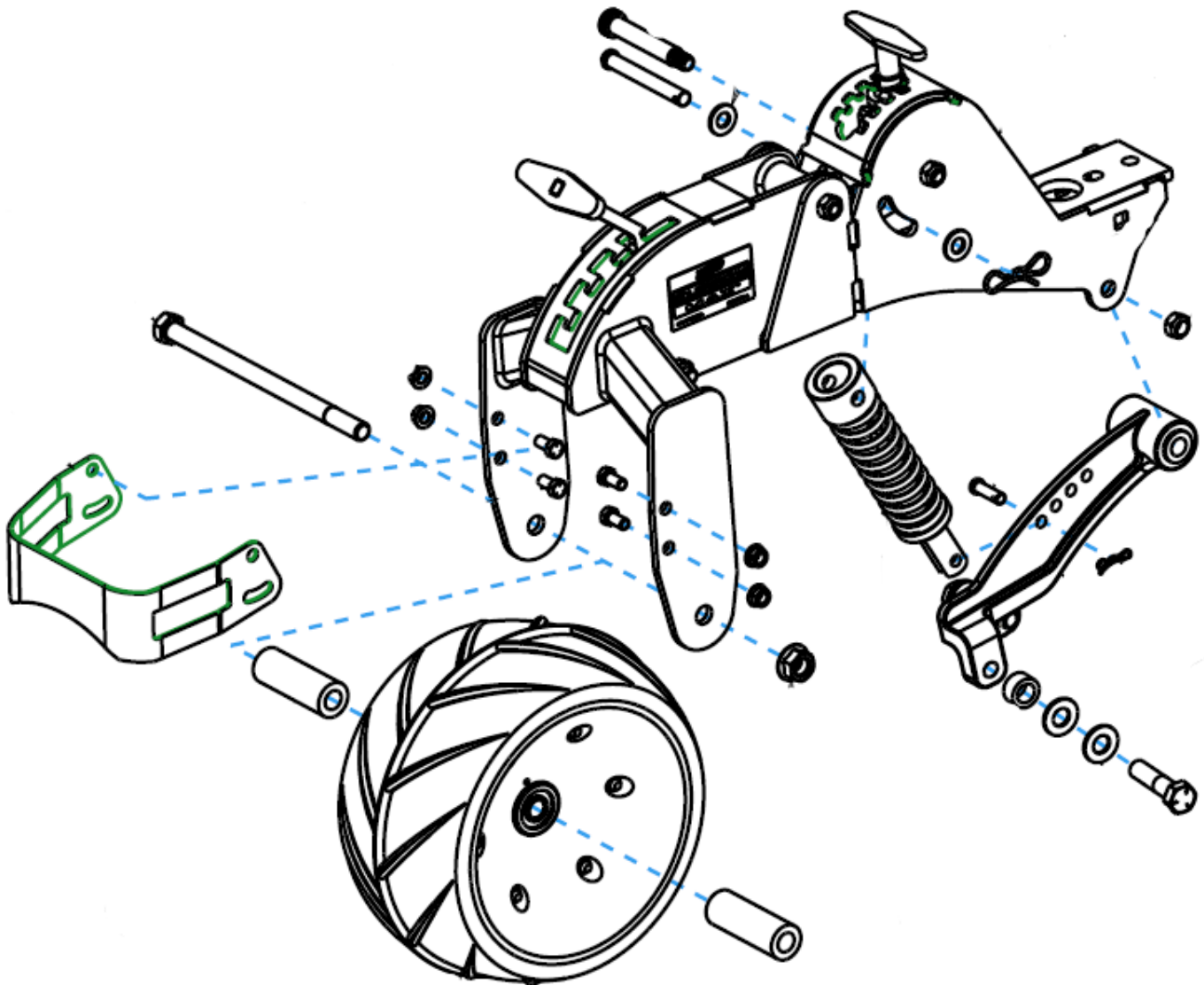

# INSTALLATION INSTRUCTIONS

## Kinze 4900 6200-073

### STEP 1:

Remove the closing wheel arm, spring and pivot bolts.

### STEP 2:

Install the Furrow max sub assembly by first putting the ½" carriage bolts through the old pivot bolt holes. Next put the 7/16" bolt through the lower hole where the old down pressure spring attached. Tighten the carriage bolts and the 7/16" bolt. Next adjust the ¾" bolt out to the point that it has a light amount of tension on the back of the row unit, and then tighten the jam nut.

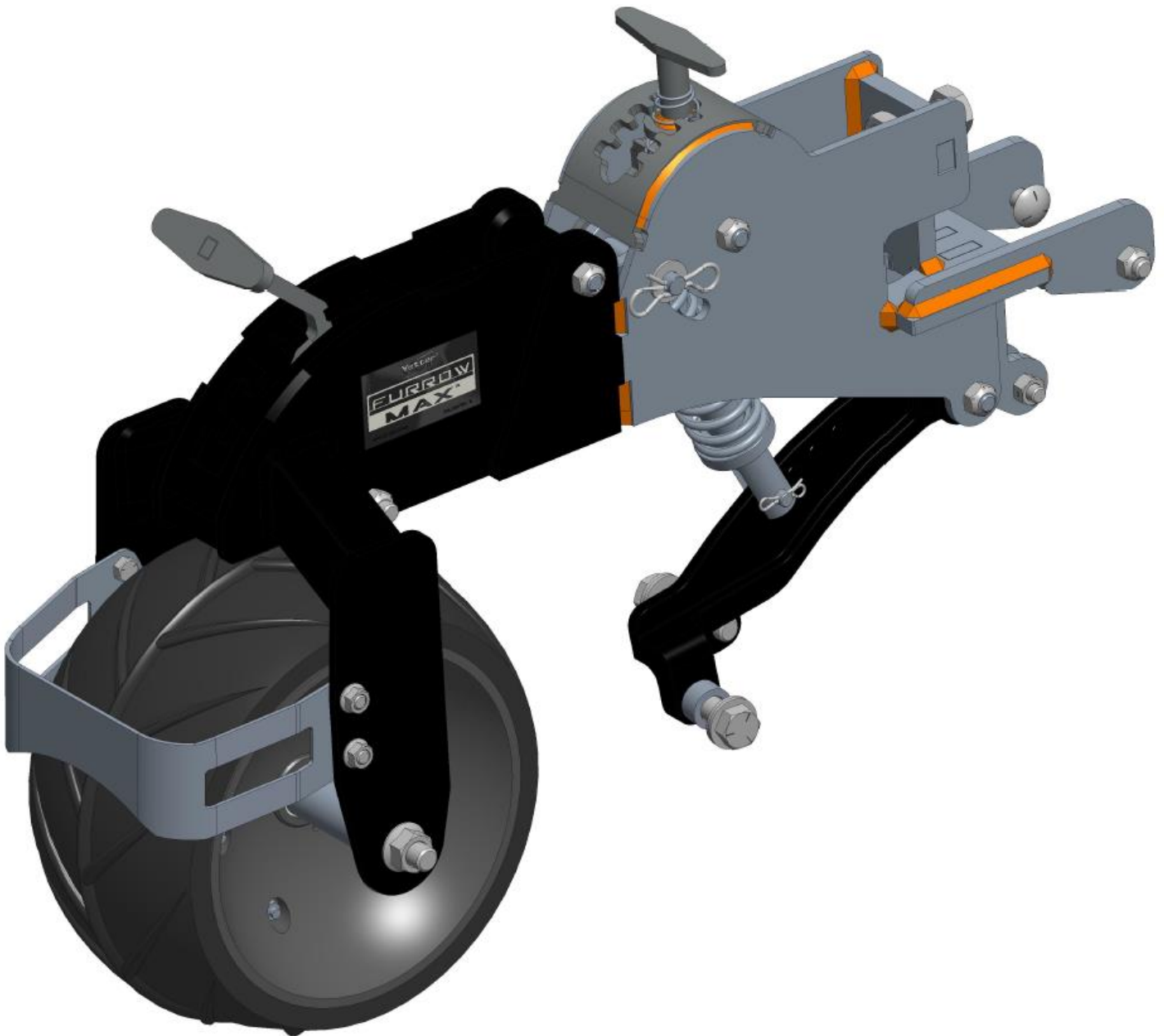

**STEP 3:**

Use the ½" x 3.75" pin, washers, and cotter pin to attach the spring to the disc pivot bracket. Use the shoulder bolt and locknut to attach the cast closing disc arm to the main body. Use the 3/8" x 1.25" pin and cotter pin to attach the spring to the cast arm in the 3<sup>rd</sup> hole.

Install the 6 x 12" rubber press wheel onto the rear mount using the 5/8 x 10.5" bolt and serrated flange nut, putting a bushing on each side.

Use the 3/8 x .75" bolts to install the mud scraper. It can be adjusted up or down so it is close to the wheel, but not touching.

Attach the closing disc's to the cast arm using the 9/16 spacer between the disc and the arm only. (Additional washers and spacers are for adjusting the disc's wider or narrower)

## OPERATION

The front closing disc need to collapse the sidewall and close the seed trench. They need to be run at or above seed depth. The front adjustment handle is for making small adjustment in down pressure. Big adjustments can be made by changing where the spring attaches to the cast spine. If the seed trench can not be collapsed, you can narrow up the spacing on the dual closing disc by changing the spacers. The recommended starting setting is (1) 9/16" bushing in between the closing disc and the cast arm. This can be removed and replaced with the 9/32" bushing that is also provided for narrower spacing.

The rear firming wheel is used to take air pockets out of the seed trench. The down pressure can be adjusted to remove the air pockets and set the density of the soil.

**PART IDENTIFICATION**  
**6200-070**  
**John Deere 7200/7300/1700**

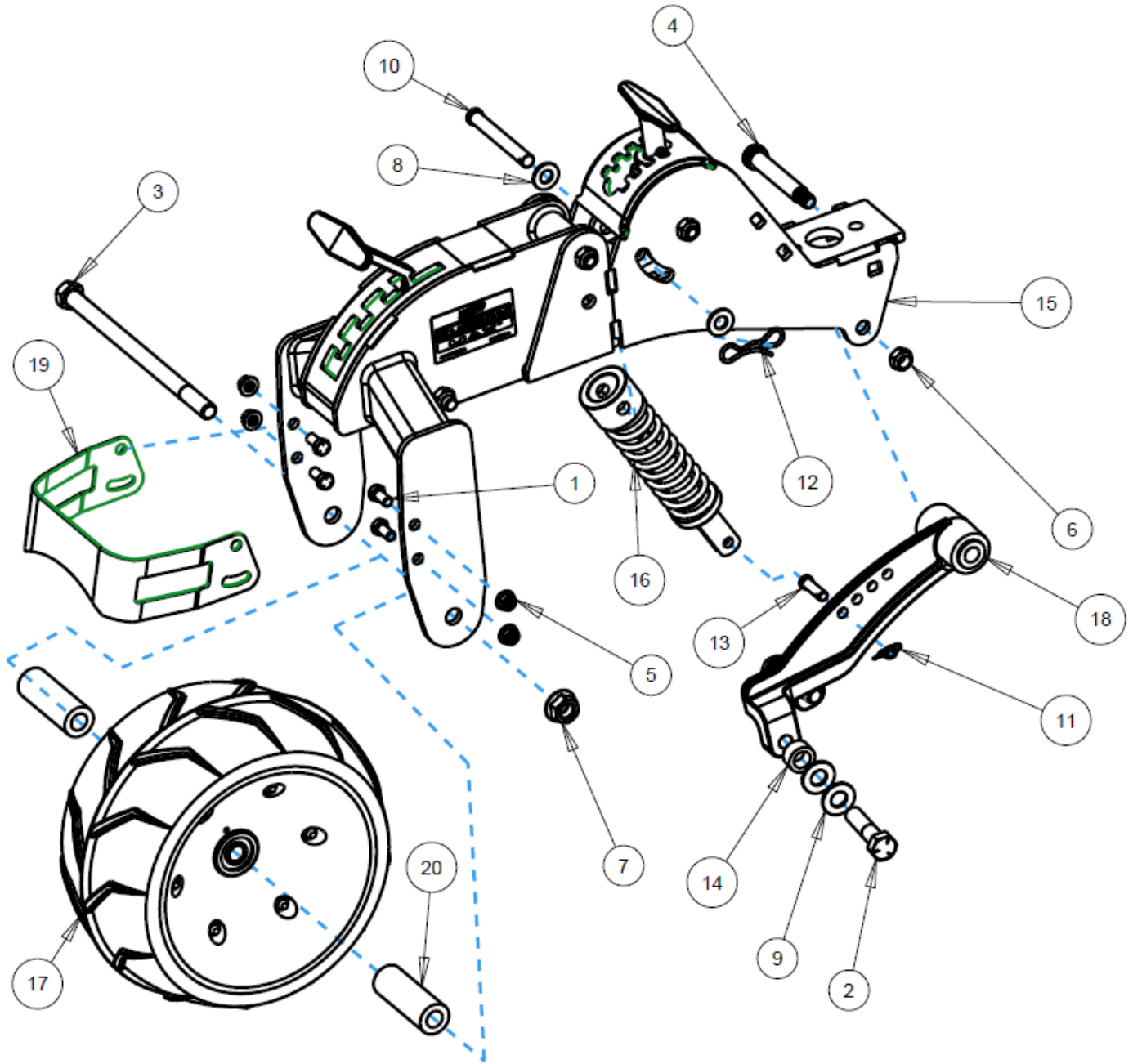

ITEM	PART NO.	DESCRIPTION	QTY
1	2502-230	3/8-16 X 3/4 HHCS GR 5 ZP	4
2	2502-393	5/8-11 X 2 1/2 HHCS GR5 ZP	2
3	2502-442	5/8-11 X 10-1/2 HHCS GR5 ZP	1
4	2510-122	5/8" DIA. SHLDR BLT., 3.250" L SHLDR, 1/2-13	1
5	2520-260	3/8-16 SERRATED FLANGE LOCK NUT GR. 5 ZP	4
6	2520-362	1/2-13 HEX LOCK NUT, GR C, ZP	1
7	2520-478	5/8-11 SER. FLNG NUT, GR 8, ZP W/THDLOCK	1
8	2526-352	1/2 SAE FLATWASHER ZP	2
9	2526-453	5/8 SAE FLATWASHER ZP	4
10	2529-508	CLEVIS PIN, .5 X 3.75 USABLE	1
11	2570-441	5/64 LOCKING COTTER FOR 3/8" PIN, 1-1/14" LONG	1
12	2570-448	.120 BOWTIE LOCKING COTTER ZP	1
13	2959-317	CLEVIS PIN, ZP .375" X 1.25"	1
14	2960-354	PIVOT SPACER; 9/16"; ZP	2
15	6200-185	FURROW MAX, SUB-ASSY, BLK, DEERE	1
16	6200-189	CLOSE DISC SPRING ASSEMBLY	1
17	6200-363	6.5 X 12 PRESS	1
18	6200-496	CLOSE DISC ARM, BLACK	1
19	6200-510	PRESS WHEEL SCRAPER	1
20	6200-523	PRESS WHEEL SPACER, FURROW MAX	2



# PART IDENTIFICATION

6200-071

Kinze 3000

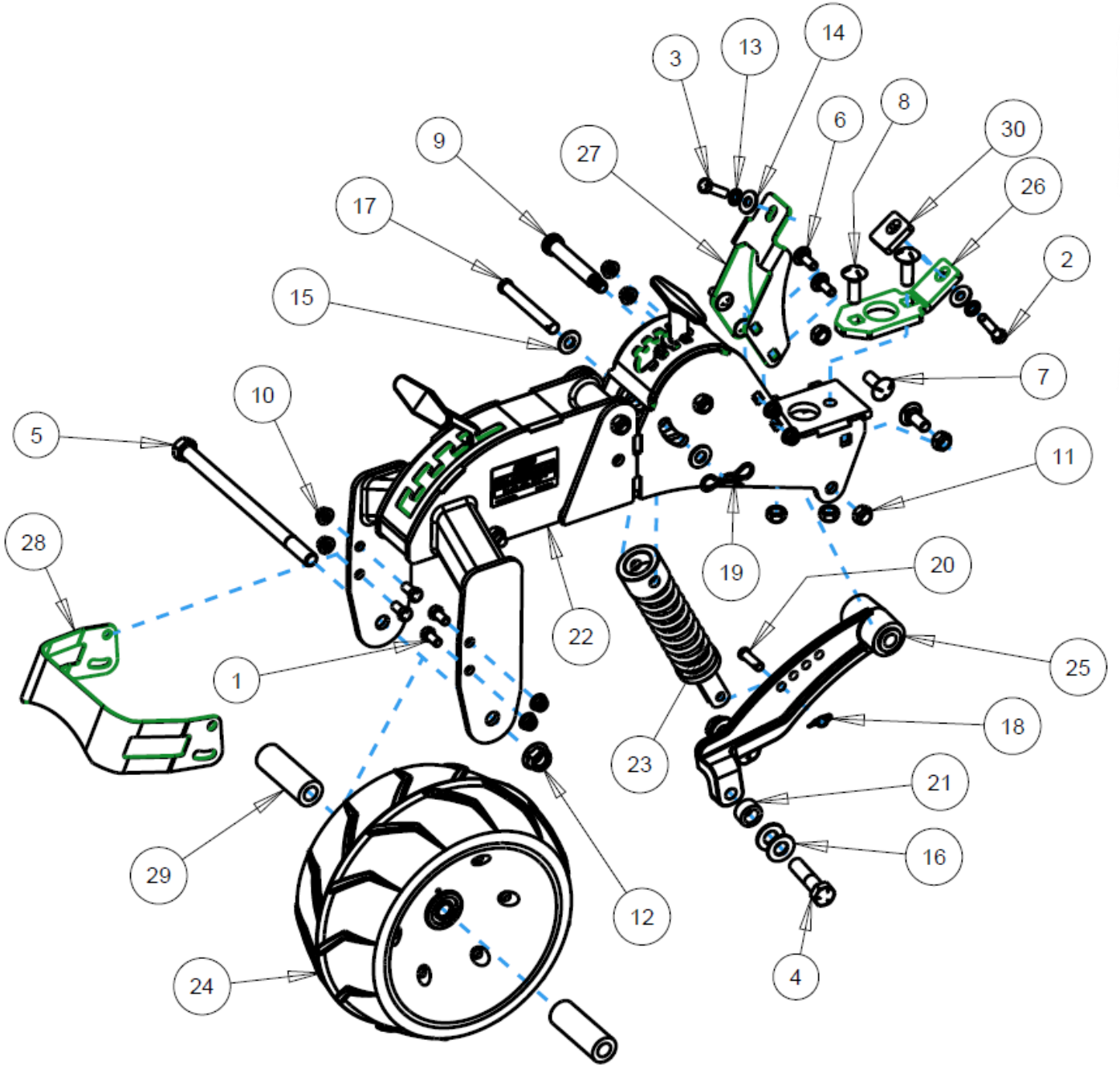

ITEM	PART NO.	DESCRIPTION	QTY
1	2502-230	3/8-16 X 3/4 HHCS GR 5 ZP	4
2	2502-232	3/8-16 X 1 1/2 HHCS GR 5 ZP	1
3	2502-244	3/8-16 X 1-1/4 HHCS GR 5 ZP	1
4	2502-393	5/8-11 X 2 1/2 HHCS GR5 ZP	2
5	2502-442	5/8-11 X 10-1/2 HHCS GR5 ZP	1
6	2505-260	3/8-16 X 1 CARBLT GR5 ZP	4
7	2505-337	1/2-13 X 1 1/4 CARBLT G5ZP	2
8	2505-339	1/2-13 X 1-1/2 CARBLT G5ZP	2
9	2510-122	5/8" DIA. SHLDR BLT., 3.250" L SHLDR, 1/2-13	1
10	2520-260	3/8-16 SERRATED FLANGE LOCK NUT GR. 5 ZP	8
11	2520-362	1/2-13 HEX LOCK NUT, GR C, ZP	5
12	2520-478	5/8-11 SER. FLNG NUT, GR 8, ZP W/THDLOCK	1
13	2525-251	3/8 MED. LOCKWASHER ZP.	2
14	2526-251	3/8 STANDARD FLATWASHER ZP	2
15	2526-352	1/2 SAE FLATWASHER ZP	2
16	2526-453	5/8 SAE FLATWASHER ZP	4
17	2529-508	CLEVIS PIN, .5 X 3.75 USABLE	1
18	2570-441	5/64 LOCKING COTTER FOR 3/8" PIN, 1-1/14" LONG	1
19	2570-448	.120 BOWTIE LOCKING COTTER ZP	1
20	2959-317	CLEVIS PIN, ZP .375" X 1.25"	1
21	2960-354	PIVOT SPACER; 9/16"; ZP	2
22	6200-185	FURROW MAX, SUB-ASSY, BLK, DEERE	1
23	6200-189	CLOSE DISC SPRING ASSEMBLY	1
24	6200-363	6.5 X 12 PRESS	1
25	6200-496	CLOSE DISC ARM, BLACK	1
26	6200-498	KINZE MOUNT ADAPTER	1
27	6200-499	KINZE MOUNT BRACKET	1
28	6200-510	PRESS WHEEL SCRAPER	1
29	6200-523	PRESS WHEEL SPACER, FURROW MAX	2
30	6200-542	SPACER BLOCK	1

# PART IDENTIFICATION

6200-072

White 9000

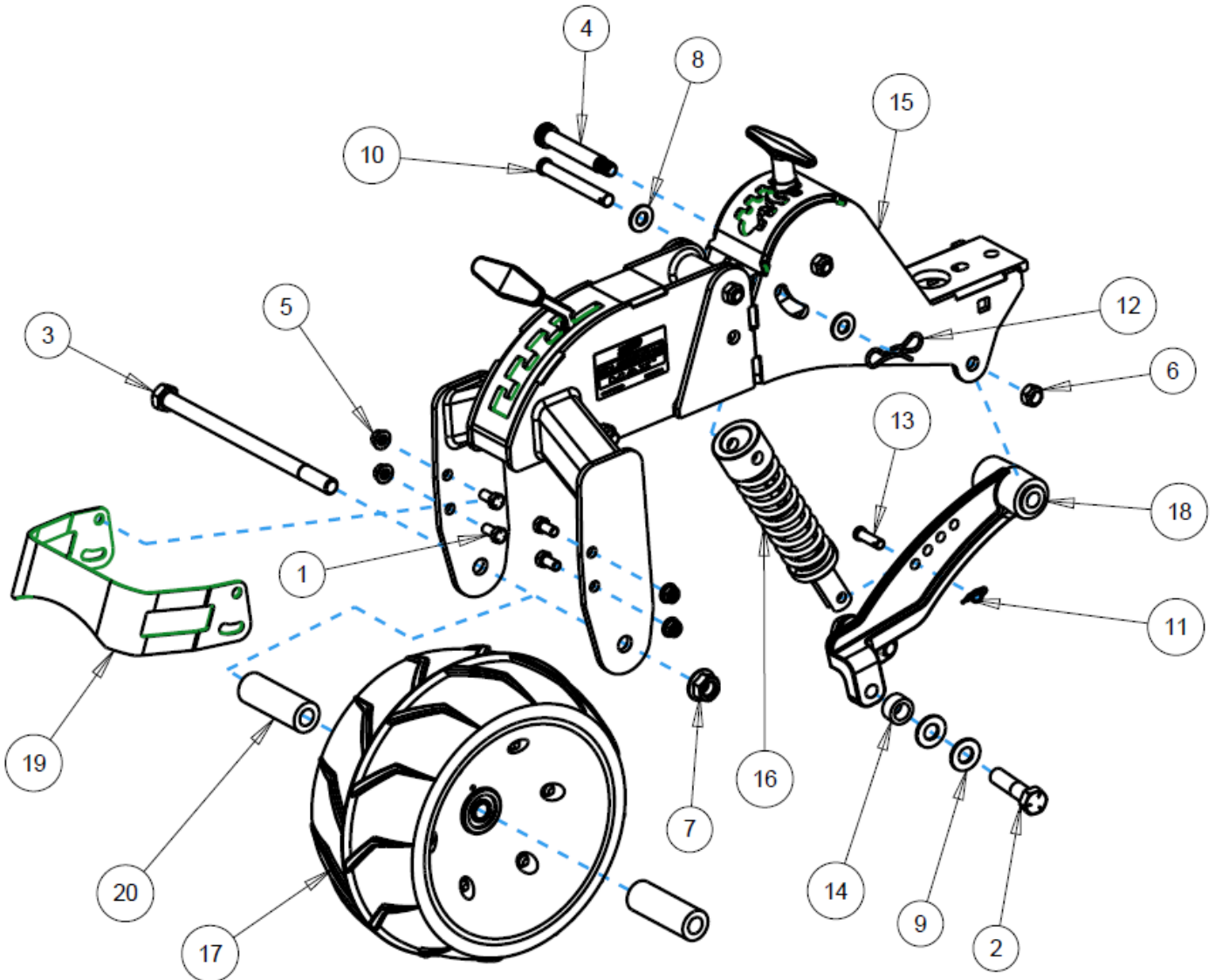

ITEM	PART NO.	DESCRIPTION	QTY
1	2502-230	3/8-16 X 3/4 HHCS GR 5 ZP	4
2	2502-393	5/8-11 X 2 1/2 HHCS GR5 ZP	2
3	2502-442	5/8-11 X 10-1/2 HHCS GR5 ZP	1
4	2510-122	5/8" DIA. SHLDR BLT., 3.250" L SHLDR, 1/2-13	1
5	2520-260	3/8-16 SERRATED FLANGE LOCK NUT GR. 5 ZP	4
6	2520-362	1/2-13 HEX LOCK NUT, GR C, ZP	1
7	2520-478	5/8-11 SER. FLNG NUT, GR 8, ZP W/THDLOCK	1
8	2526-352	1/2 SAE FLATWASHER ZP	2
9	2526-453	5/8 SAE FLATWASHER ZP	4
10	2529-508	CLEVIS PIN, .5 X 3.75 USABLE	1
11	2570-441	5/64 LOCKING COTTER FOR 3/8" PIN, 1-1/14" LONG	1
12	2570-448	.120 BOWTIE LOCKING COTTER ZP	1
13	2959-317	CLEVIS PIN, ZP .375" X 1.25"	1
14	2960-354	PIVOT SPACER; 9/16"; ZP	2
15	6200-182	FURROW MAX, SUB-ASSY, WHITE 9000	1
16	6200-189	CLOSE DISC SPRING ASSEMBLY	1
17	6200-363	6.5 X 12 PRESS	1
18	6200-496	CLOSE DISC ARM, BLACK	1
19	6200-510	PRESS WHEEL SCRAPER	1
20	6200-523	PRESS WHEEL SPACER, FURROW MAX	2

# PART IDENTIFICATION

6200-073

Kinze 4000

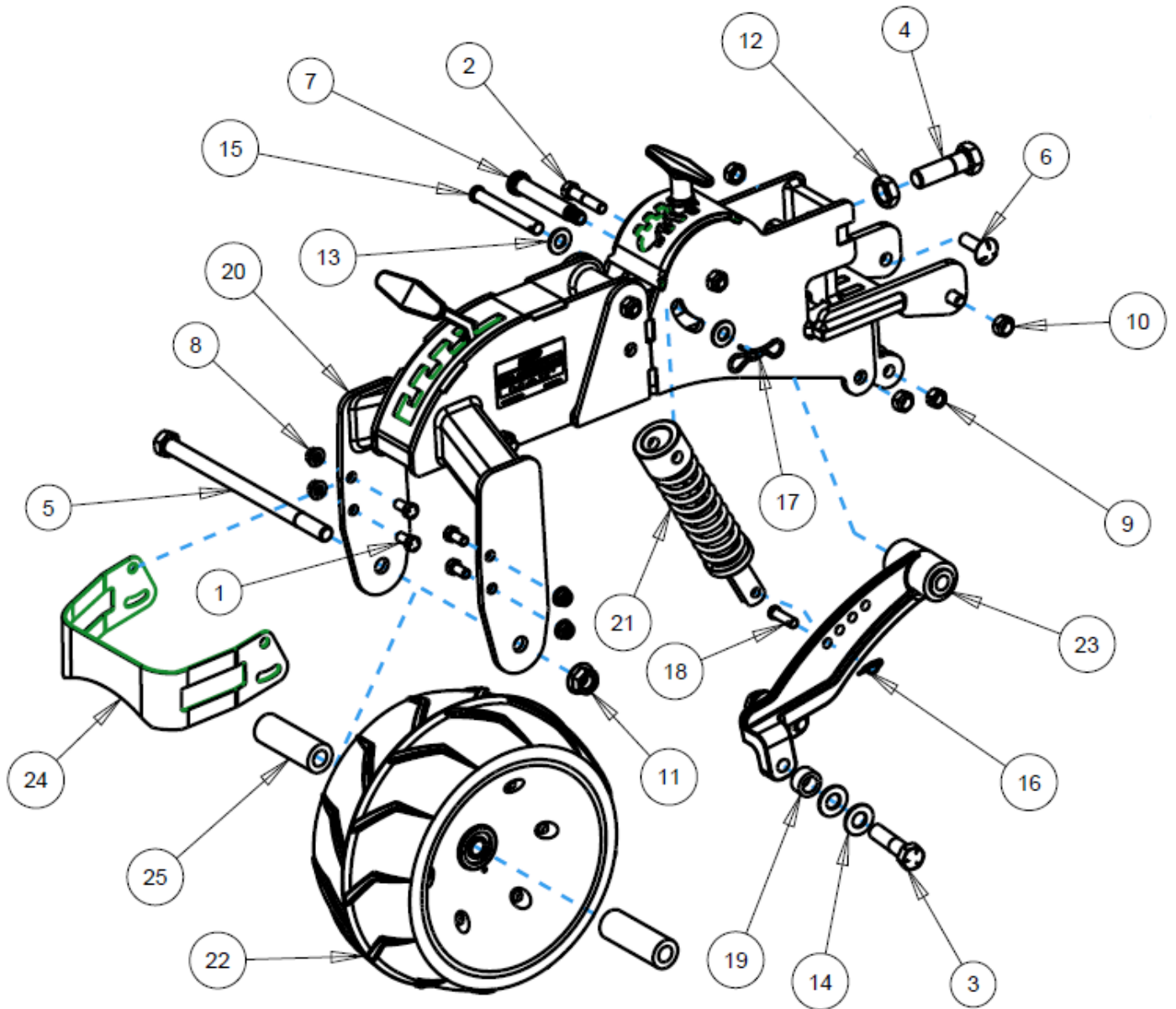

ITEM	PART NO.	DESCRIPTION	QTY
1	2502-230	3/8-16 X 3/4 HHCS GR 5 ZP	4
2	2502-267	7/16-14 X 2 HHCS GR 5 ZP	1
3	2502-393	5/8-11 X 2 1/2 HHCS GR5 ZP	2
4	2502-407	3/4-10 X 2-1/2 HHCS GR5 ZP	1
5	2502-442	5/8-11 X 10-1/2 HHCS GR5 ZP	1
6	2505-339	1/2-13 X 1-1/2 CARBLT G5ZP	2
7	2510-122	5/8" DIA. SHLDR BLT., 3.250" L SHLDR, 1/2-13	1
8	2520-260	3/8-16 SERRATED FLANGE LOCK NUT GR. 5 ZP	4
9	2520-267	7/16-14 LCK HX NT ZP	1
10	2520-362	1/2-13 HEX LOCK NUT, GR C, ZP	3
11	2520-478	5/8-11 SER. FLNG NUT, GR 8, ZP W/THDLOCK	1
12	2520-502	3/4-10 HEX JAM NUT, GR 2, ZP	2
13	2526-352	1/2 SAE FLATWASHER ZP	2
14	2526-453	5/8 SAE FLATWASHER ZP	4
15	2529-508	CLEVIS PIN, .5 X 3.75 USABLE	1
16	2570-441	5/64 LOCKING COTTER FOR 3/8" PIN, 1-1/14" LONG	1
17	2570-448	.120 BOWTIE LOCKING COTTER ZP	1
18	2959-317	CLEVIS PIN, ZP .375" X 1.25"	1
19	2960-354	PIVOT SPACER; 9/16"; ZP	2
20	6200-187	FURROW MAX, SUB-ASSY, BLACK, KINZE 4900	1
21	6200-189	CLOSE DISC SPRING ASSEMBLY	1
22	6200-363	6.5 X 12 PRESS	1
23	6200-496	CLOSE DISC ARM, BLACK	1
24	6200-510	PRESS WHEEL SCRAPER	1
25	6200-523	PRESS WHEEL SPACER, FURROW MAX	2

**PART IDENTIFICATION**  
**John Deere 7200/7300/1700**  
**6200-080 V-Closing wheel kit**

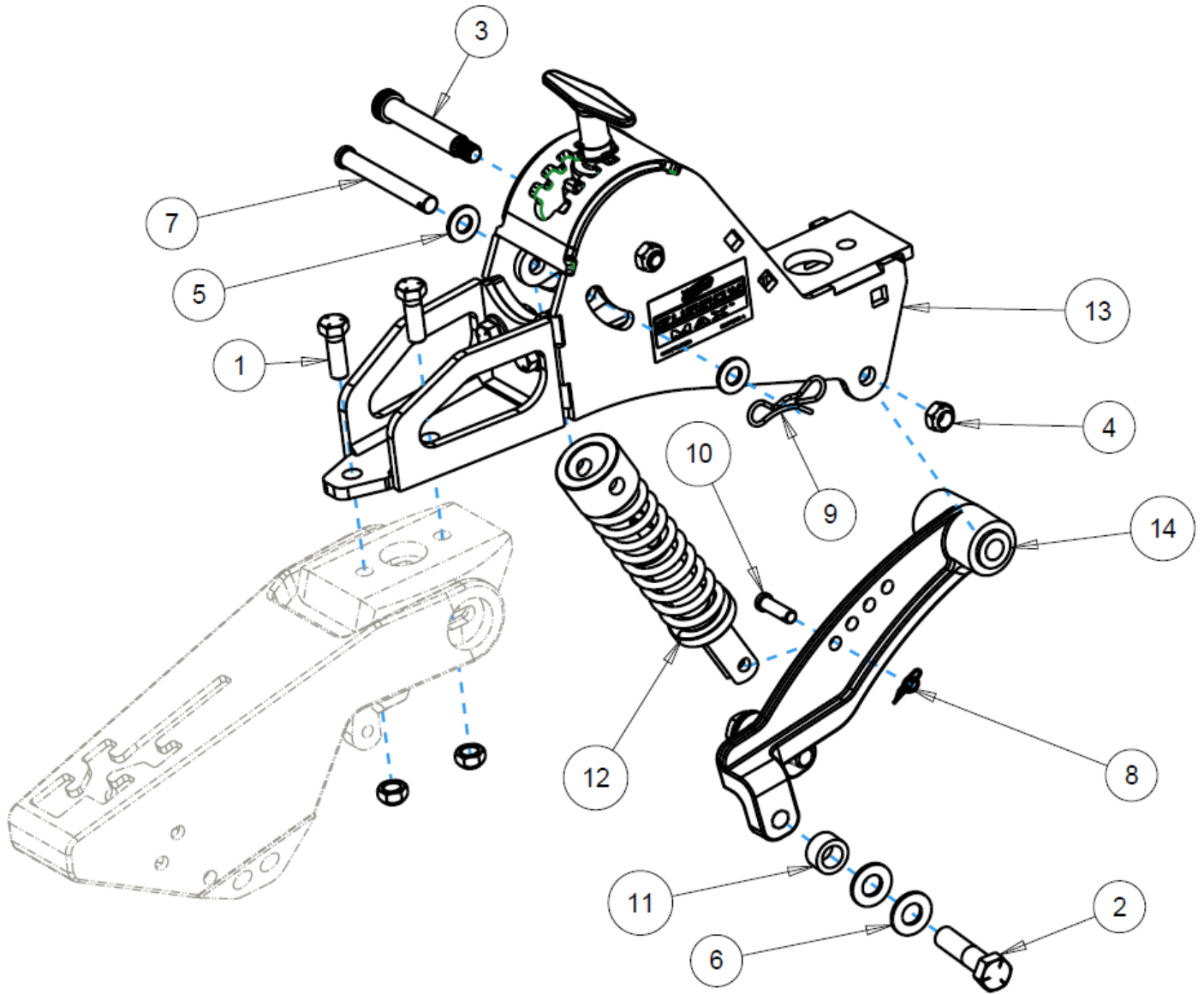

ITEM	PART NO.	DESCRIPTION	QTY
1	2502-294	1/2-13 X 1-1/2 HHCS GR5 ZP	2
2	2502-393	5/8-11 X 2 1/2 HHCS GR5 ZP	2
3	2510-122	5/8" DIA. SHLDR BLT., 3.250" L SHLDR, 1/2-13	1
4	2520-362	1/2-13 HEX LOCK NUT, GR C, ZP	3
5	2526-352	1/2 SAE FLATWASHER ZP	2
6	2526-453	5/8 SAE FLATWASHER ZP	4
7	2529-508	CLEVIS PIN, .5 X 3.75 USABLE	1
8	2570-441	5/64 LOCKING COTTER FOR 3/8" PIN, 1-1/14" LONG	1
9	2570-448	.120 BOWTIE LOCKING COTTER ZP	1
10	2959-317	CLEVIS PIN, ZP .375" X 1.25"	1
11	2960-354	PIVOT SPACER; 9/16"; ZP	2
12	6200-189	CLOSE DISC SPRING ASSEMBLY	1
13	6200-192	FURROW MAX, L/FIRMING, BLACK, SUB-ASSY	1
14	6200-496	CLOSE DISC ARM, BLACK	1



# PART IDENTIFICATION

## 6000-013A

### 8" Serrated

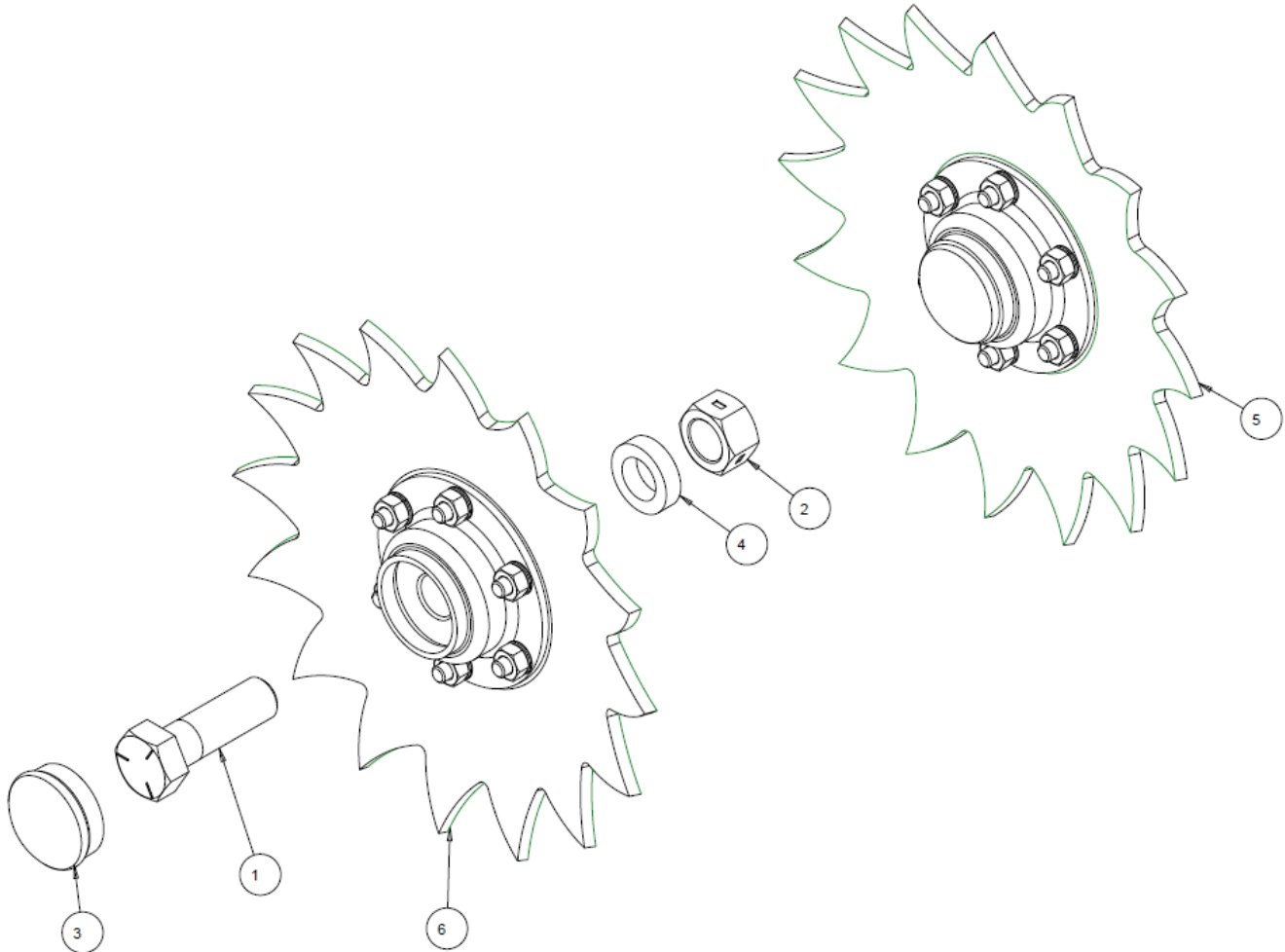

ITEM	PART NO.	DESCRIPTION	QTY
1	2502-391	5/8-11 X 2 HHCS GR 5 ZP	2
2	2520-459	5/8-11 LOCK HEX NUT, GR B, ZP	2
3	2570-789	HUB CAP	2
4	2967-468	9/32" PIVOT ARM BUSHING	2
5	6000-108 8"	SERRATED CLOSE DISC ASSY, LH, CNH 1	1
6	6000-109 8"	SERRATED CLOSE DISC ASSY. RH, CNH 1	1

# PART IDENTIFICATION

## 6000-017

### 8" Smooth

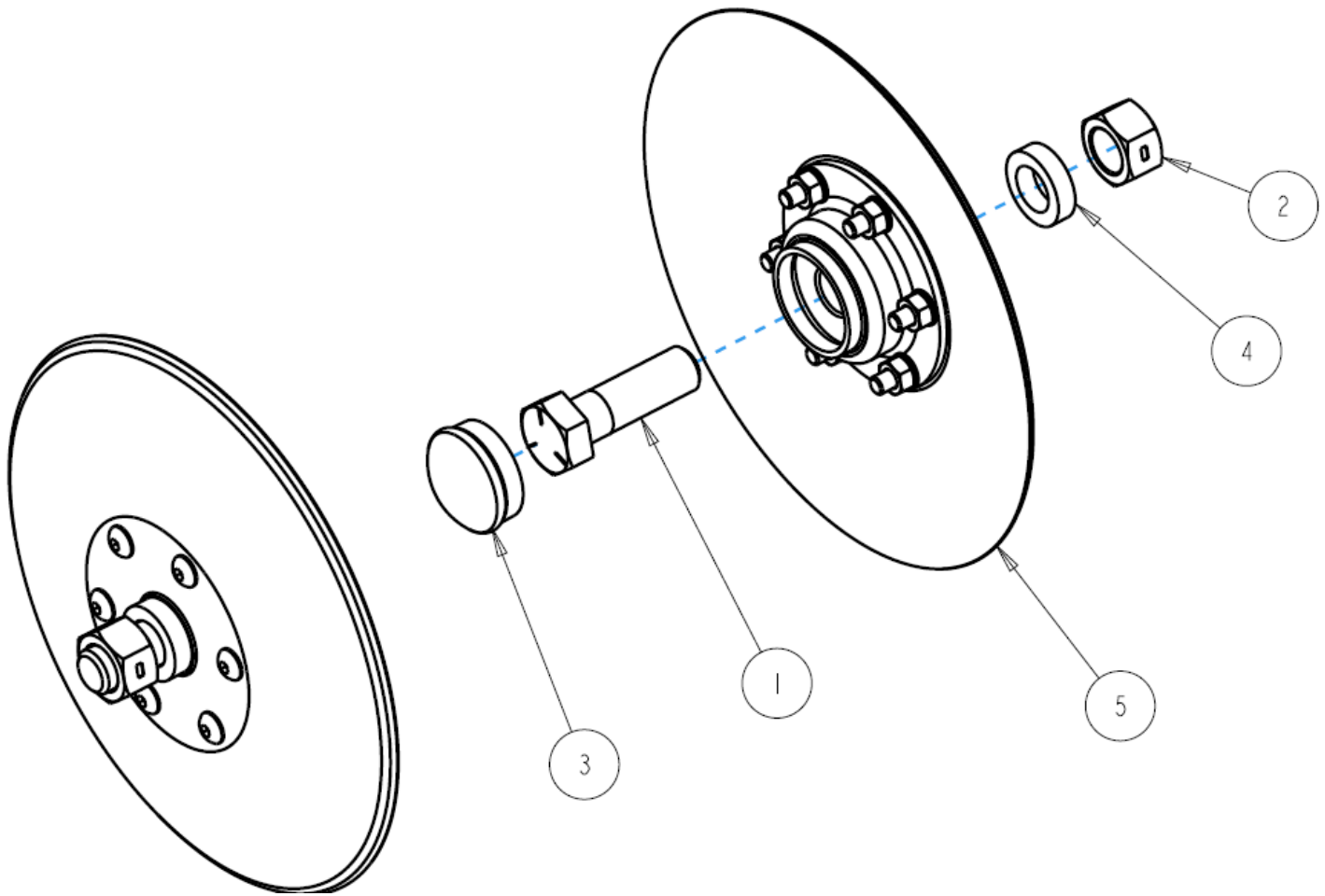

ITEM	PART NO.	DESCRIPTION	QTY
1	2502-391	5/8-11 X 2 HHCS GR 5 ZP	2
2	2520-459	5/8-11 LOCK HEX NUT, GR B, ZP	2
3	2570-789	HUB CAP	2
4	2967-468	9/32" PIVOT ARM BUSHING	2
5	6000-113	8" SMOOTH CLOSE DISC ASSY, CNH	2

# PART IDENTIFICATION

## 6200-085-LH (shown) 6200-085-RH

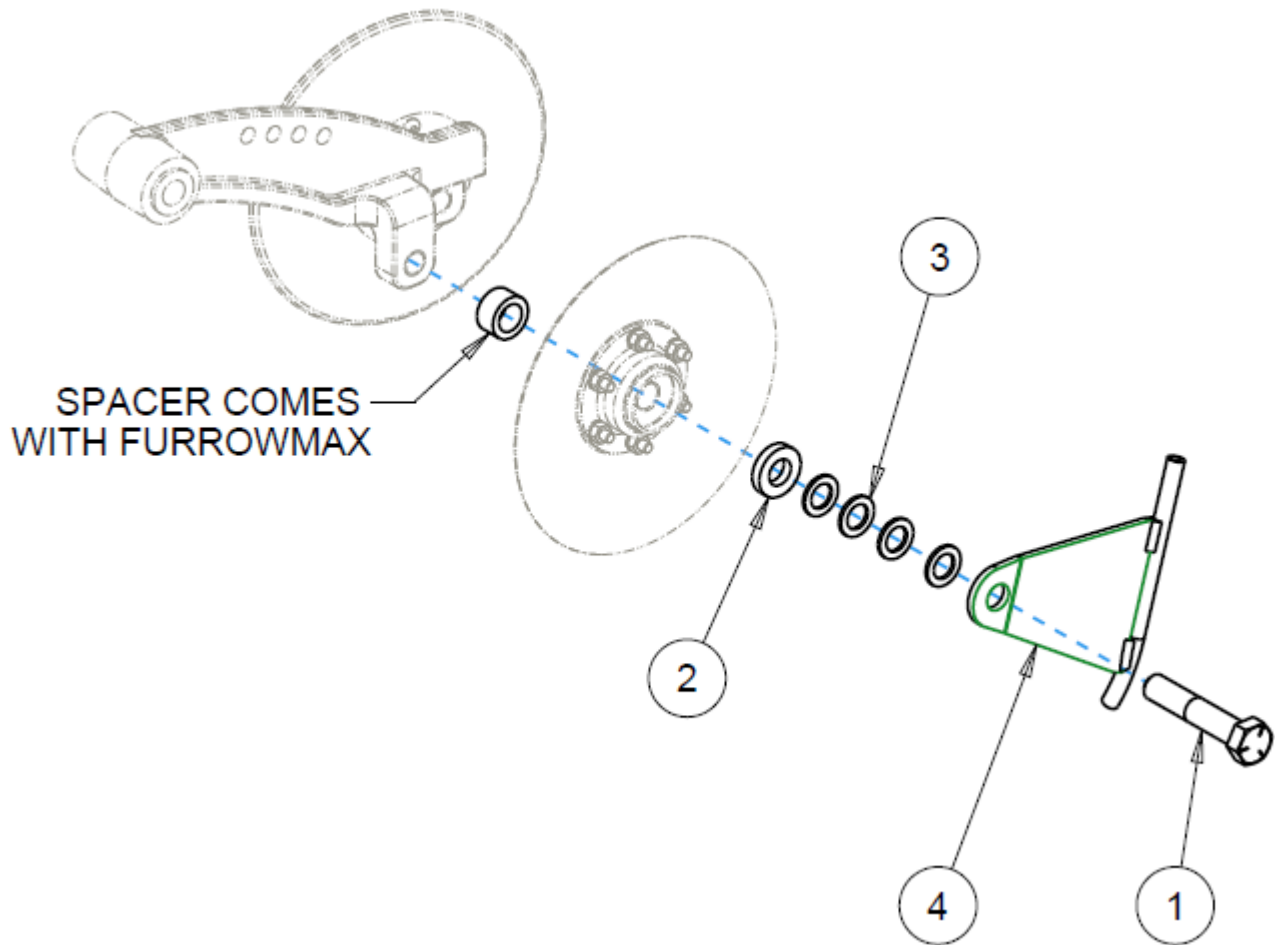

Item	PART NO.	DESCRIPTION	QTY.
1	2502-385	5/8-11 X 3-1/4 HHCS GR5 ZP	1
2	2526-455	WASH 21/32" X 1 1/4" X 1/4	1
3	2527-563	5/8ID X1"OD X14GA MACH BU	4
4	6200-249	LIQUID TUBE W.A., L.H., STAINLESS	1
4	6200-250	LIQUID TUBE W.A., R.H., STAINLESS	1

# PART IDENTIFICATION

## 6200-182

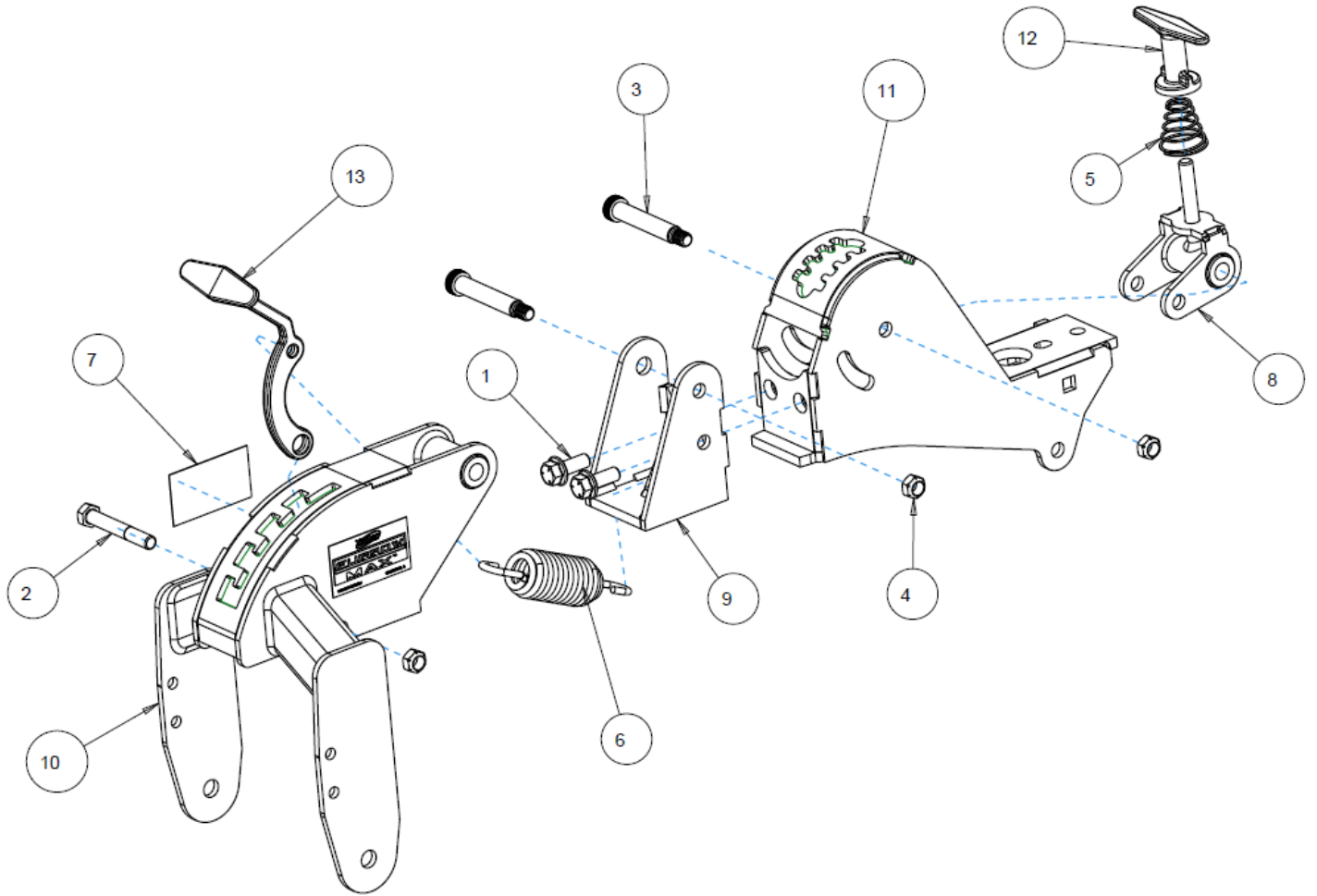

ITEM	PART NO.	DESCRIPTION	QTY
1	2502-310	1/2-13 X 1 1/4 SERRATED FLANGE HHCS GR5	2
2	2502-316	1/2-13 X 3-1/2 HHCS GR5 ZP	1
3	2510-122	5/8" DIA. SHLDR BLT., 3.250" L SHLDR, 1/2-13	2
4	2520-362	1/2-13 HEX LOCK NUT, GR C, ZP	3
5	2550-786	CONICAL COMP SPRING, 1.75" X .875" OD, 1.59" X .715"	1
6	2550-787	TAPERED END EXTENSION SPRING	1
7	2565-835	FURROW MAX DECAL, 3-1/2 X 2	2
8	6200-243	PIVOT BRACKET W.A.	1
9	6200-245-BLACK	PRESS WHEEL MOUNT W.A., PAINTED BLACK	1
10	6200-246-BLACK	PRESS WHEEL W.A., PAINTED BLACK	1
11	6200-247	MAIN BODY W.A., WHITE 9000	1
12	6200-442	T-HANDLE, FURROW MAX	1
13	6200-545	SPRING ADJUST HANDLE	1

# PART IDENTIFICATION

## 6200-185

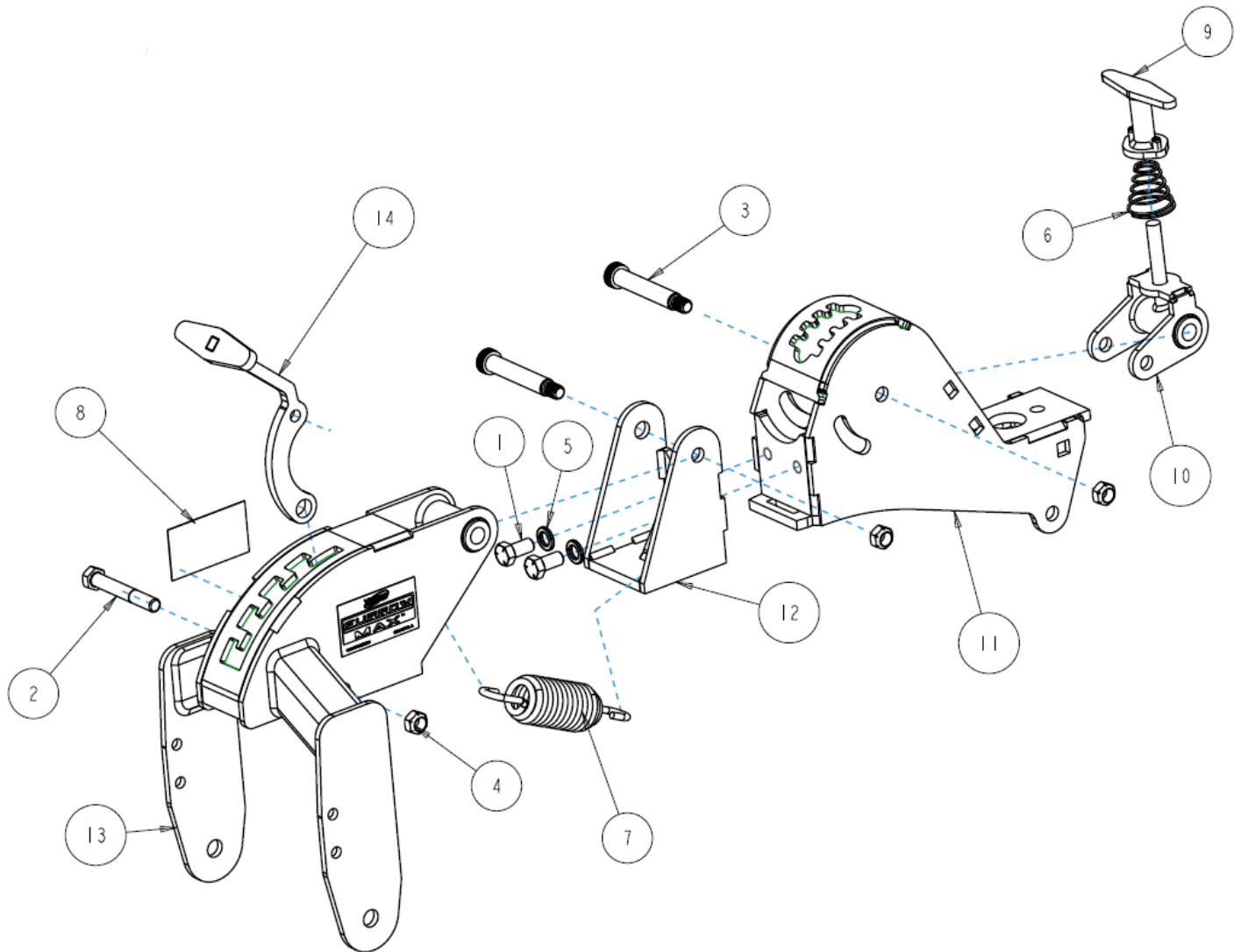

ITEM	PART NO.	DESCRIPTION	QTY
1	2502-292	1/2-13 X 1 HHCS GR. 5 ZP	2
2	2502-316	1/2-13 X 3-1/2 HHCS GR5 ZP	1
3	2510-122	5/8" DIA. SHLDR BLT., 3.250" L SHLDR, 1/2-13	2
4	2520-362	1/2-13 HEX LOCK NUT, GR C, ZP	3
5	2525-352	1/2 MED LOCKWASHER ZP.	2
6	2550-786	CONICAL COMP SPRING, 1.75" X .875" OD, 1.59" X .715"	1
7	2550-787	TAPERED END EXTENSION SPRING	1
8	2565-835	FURROW MAX DECAL, 3-1/2 X 2	2
9	6200-242	T-HANDLE W.A.	1
10	6200-243	PIVOT BRACKET W.A.	1
11	6200-244-BLACK	MAIN BODY W.A., PAINTED BLACK	1
12	6200-245-BLACK	PRESS WHEEL MOUNT W.A., PAINTED BLACK	1
13	6200-246-BLACK	PRESS WHEEL W.A., PAINTED BLACK	1
14	6200-251	SPRING ADJUST HANDLE W.A.	1

# PART IDENTIFICATION

## 6200-187

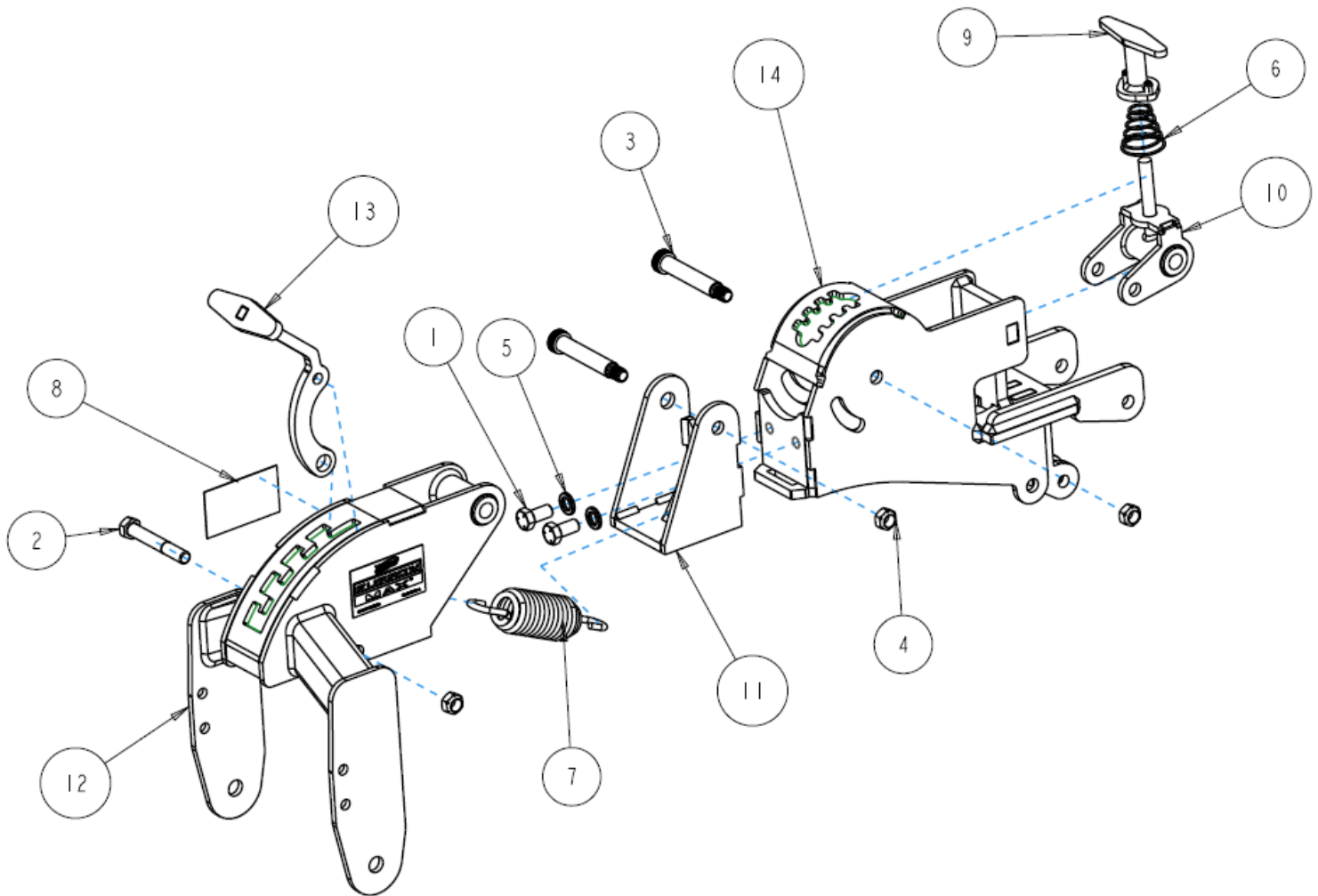

ITEM	PART NO.	DESCRIPTION	QTY
1	2502-310	1/2-13 X 1 1/4 SERRATED FLANGE HHCS GR5	2
2	2502-316	1/2-13 X 3-1/2 HHCS GR5 ZP	1
3	2510-122	5/8" DIA. SHLDR BLT., 3.250" L SHLDR, 1/2-13	2
4	2520-362	1/2-13 HEX LOCK NUT, GR C, ZP	3
5	2550-786	CONICAL COMP SPRING, 1.75" X .875" OD, 1.59" X .715"	1
6	2550-787	TAPERED END EXTENSION SPRING	1
7	2565-835	FURROW MAX DECAL, 3-1/2 X 2	2
8	6200-243	PIVOT BRACKET W.A.	1
9	6200-245-BLACK	PRESS WHEEL MOUNT W.A., PAINTED BLACK	1
10	6200-246-BLACK	PRESS WHEEL W.A., PAINTED BLACK	1
11	6200-247	MAIN BODY W.A., WHITE 9000	1
12	6200-442	T-HANDLE, FURROW MAX	1
13	6200-545	SPRING ADJUST HANDLE	1

# PART IDENTIFICATION

## 6200-189

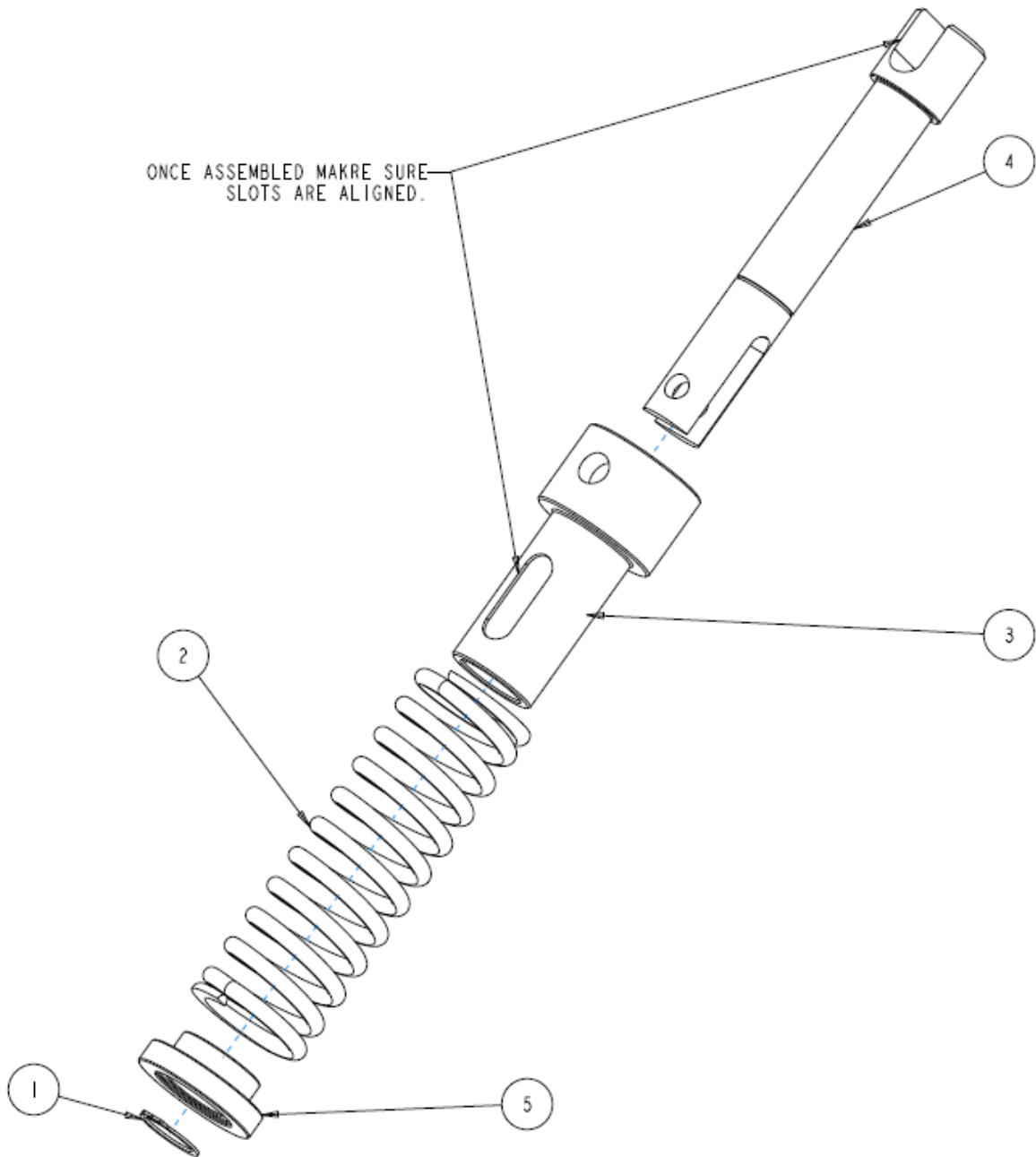

ITEM	PART NO.	DESCRIPTION	QTY
1	2550-528	SNAP RING, EXTERNAL FOR 15/16" O.D.	1
2	2550-788	SPRING, 6" LONG X 1.938 OD X .25 WIRE	1
3	6200-527	SPRING TOP PIVOT	1
4	6200-528	LOWER SPRING MOUNT PIN	1
5	6200-529	SPRING RETAINING CAP	1

# PART IDENTIFICATION

## 6200-192

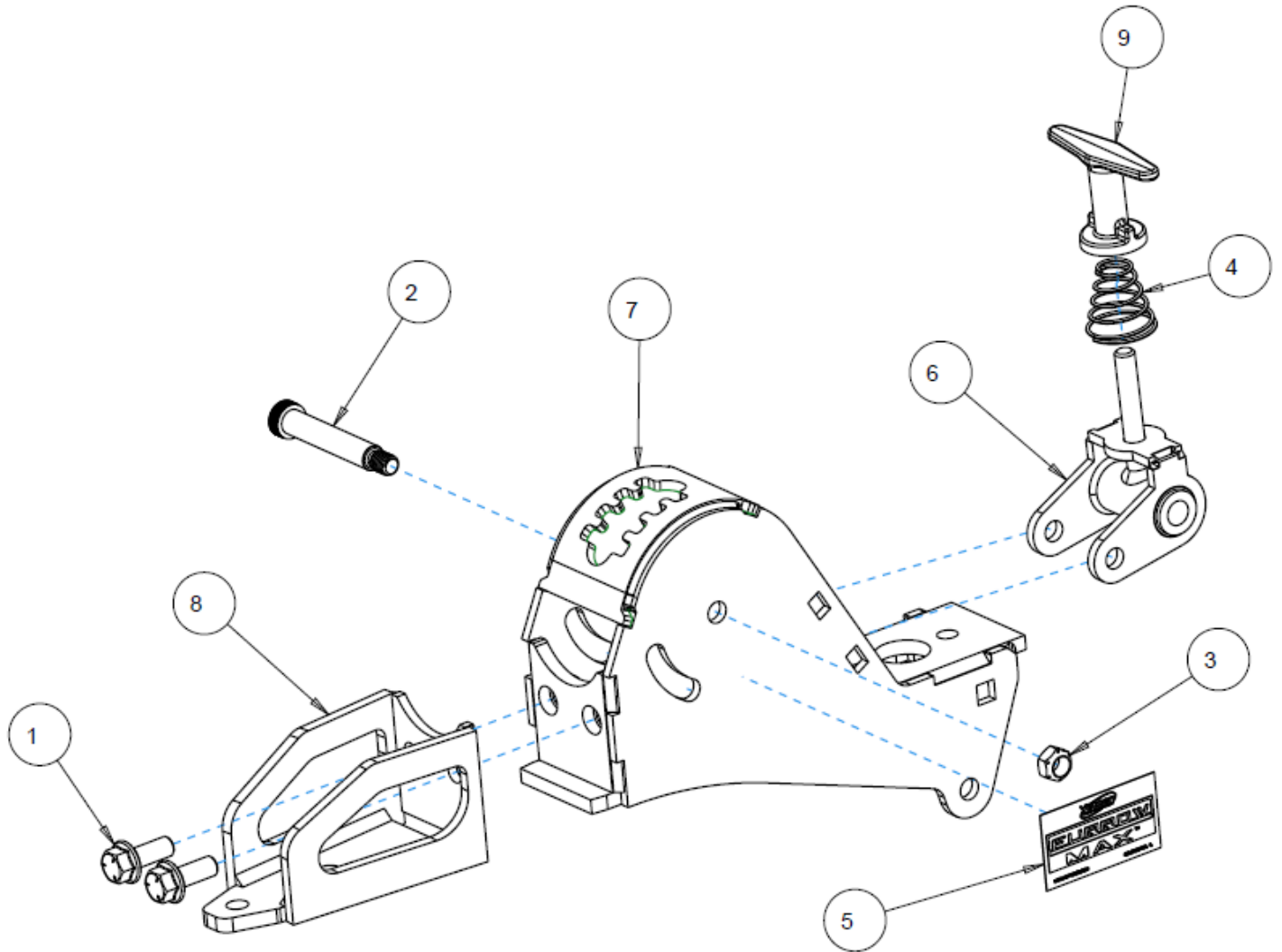

ITEM	PART NO.	DESCRIPTION	QTY
1	2502-310	1/2-13 X 1 1/4 SERRATED FLANGE HHCS GR5	2
2	2510-122	5/8" DIA. SHLDR BLT., 3.250" L SHLDR, 1/2-13	1
3	2520-362	1/2-13 HEX LOCK NUT, GR C, ZP	1
4	2550-786	CONICAL COMP SPRING, 1.75" X .875" OD, 1.59" X .715"	1
5	2565-835	FURROW MAX DECAL, 3-1/2 X 2	2
6	6200-243	PIVOT BRACKET W.A.	1
7	6200-244-BLACK	MAIN BODY W.A., PAINTED BLACK	1
8	6200-248-BLACK	V-CLOSING WHEEL MOUNT W.A., BLACK	1
9	6200-442	T-HANDLE, FURROW MAX	1







## NOTES:



A Tradition of Solutions since 1930

Yetter Farm Equipment Co

PO BOX 358 109 S. McDonough

Colchester, IL 62326-0358

Phone: 309-776-4111

Toll Free: 800-447-5777

Email: [info@yetterco.com](mailto:info@yetterco.com)

For updated models and manuals visit the Yetter website:

[www.yetterco.com](http://www.yetterco.com)

© Yetter Farm Equipment Co. All Rights Reserved

2565-989\_REV E – 2/2024