



**5000 SERIES
STALK
DEVASTATOR
CORN STALK ROLLER
*PATENTED***

5000-022C Lexion C512-30 / Capello/ Claas

5000-033B Lexion C508-30 / Capello/ Claas

OPERATOR'S MANUAL

PART IDENTIFICATION

2565-783_REV_D – 02/2024



YETTER MANUFACTURING CO.
FOUNDED 1930

Colchester, IL 62326-0358

Toll free: 800/447-5777

309/776-3222 (Fax)

Website: www.yetterco.com

E-mail: info@yetterco.com

YETTER

FOREWORD

You've just joined an exclusive but rapidly growing club.

For our part, we want to welcome you to the group and thank you for buying a Yetter product.

We hope your new Yetter products will help you achieve both goals-increase your productivity and increase your efficiency so that you may generate more profit.

This operator's manual has been designed into four major sections: Foreword, Safety Precautions, Installation Instructions and Parts Breakdown.



This **SAFETY ALERT SYMBOL** indicates important safety messages in the manual. When you see this symbol, be alert to the possibility of **PERSONAL INJURY** and carefully read the message that follows.

The word **NOTE** is used to convey information that is out of context with the manual text. It contains special information such as specifications, techniques and reference information of a supplementary nature.

The word **IMPORTANT** is used in the text when immediate damage will occur to the machine due

to improper technique or operation. Important will apply to the same information as specified by note only of an immediate and urgent nature.

It is the responsibility of the user to read the operator's manual and comply with the safe and correct operating procedure and to lubricate and maintain the product according to the maintenance schedule in the operator's manual.

The user is responsible for inspecting his machine and for having parts repaired or replaced when continued use of the product would cause damage or excessive wear to the other parts.

It is the user's responsibility to deliver his machine to the Yetter dealer who sold him the product for service or replacement of defective parts, which are covered by the warranty policy.

If you are unable to understand or follow the instructions provided in this publication, consult your local Yetter dealer or contact:

YETTER MANUFACTURING CO.

309/776-4111

800/447-5777

309/776-3222 (FAX)

Website: www.yetterco.com

E-mail: info@yetterco.com

WARRANTY

Yetter Manufacturing warrants all products manufactured and sold by it against defects in material. This warranty being expressly limited to replacement at the factory of such parts or products as shall appear to be defective after inspection. This warranty does not obligate the Company to bear cost of labor in replacement of parts. It is the policy of the Company to make improvements without incurring obligations to add them to any unit already sold. No warranty is made or authorized to be made, other than herein set forth. This warranty is in effect for one year after purchase.

DEALER: _____

Yetter Manufacturing warrants its own products only and cannot be responsible for damages to equipment on which mounted.



BE ALERT! YOUR SAFETY IS INVOLVED.



WATCH FOR THIS SYMBOL. IT POINTS OUT IMPORTANT SAFETY PRECAUTIONS. IT MEANS “ATTENTION---BECOME ALERT!”

It is your responsibility as an owner, operator, or supervisor to know and instruct everyone using this machine at the time of initial assignment and at least annually thereafter, of the proper operation, precautions, and work hazards which exist in the operation of the machine in accordance with OSHA regulations.

Safety Is No Accident

The following safety instructions, combined with common sense, will save your equipment from needless damage and the operator from unnecessary exposure to personal hazard. Pay special attention to the caution notes in the text. Review this manual at least once each year with new and/or experienced operators.



1. Read and understand the operator's manual before operating this machine. Failure to do so is considered a misuse of the equipment.
2. Make sure equipment is secure before operating.
3. Always keep children away from equipment when operating.
4. Make sure everyone that is not directly involved with the operation is out of the work area before beginning the operation.
5. Make sure all safety devices, shields, and guards are in place and are functional before beginning the operation.
6. Shut off power to adjust, service, or clean.
7. Keep hands, feet, and clothing away from moving parts. It is a good idea to remove all jewelry before starting the operation.
8. Visually inspect the machine periodically during operation for signs of excessive vibration, loose fasteners, and unusual noises.

PLEASE READ, VERY IMPORTANT



**SECURE CORN HEADER AGAINST
UNWANTED LOWERING BY APPLYING
THE LOCKING MECHANISM ON THE
HYDRAULIC CYLINDERS!**

1. ATTACH HEAD TO COMBINE, LOCK HEAD TO COMBINE
2. RAISE THE HEAD OFF THE GROUND AND ENGAGE THE SAFETY STOP ON THE FEEDER HOUSE CYLINDER.
3. TURN OFF COMBINE ENGINE AND REMOVE KEY.

**FOLLOW THE INSTRUCTIONS OF THE COMBINE
MANUFACTURER.**

PLEASE READ, VERY IMPORTANT



Subject to the size and weight of the corn header, one or two additional hydraulic cylinders may be required.

The combine manufacturer generally keeps the corresponding kits readily available for the dealer.

Subject to the design of the corn header and carrying capacity of the different combines, the steering axle may require the fitting of additional weights and the rear tires might need to be filled with ballast.

**FOLLOW THE INSTRUCTIONS OF THE COMBINE
MANUFACTURER.**

TABLE OF CONTENTS

INTRODUCTION	2
WARRANTY	2
SAFETY INFORMATION	3 – 5
TABLE OF CONTENTS / TORQUE / TOOLS NEEDED.....	6
ASSEMBLY INSTRUCTIONS	
5000-022C	7 – 11
5000-033B	12 – 16
OPERATION / STORAGE / LOCK UP.....	17
PARTS IDENTIFICATON	
5000-022C	18 – 19
5000-033B	20 – 21
TROUBLESHOOTING.....	22

BOLT TORQUE



Important: Over-tightening hardware can cause just as much damage as under-tightening. Tightening hardware beyond the recommended range can reduce its shock load capacity.

All hardware on the 5000 Devastator is either Grade 5 or Grade 8, unless otherwise noted. Grade 5 cap screws are marked with three radial lines on the head. Grade 8 cap screws are marked with six radial lines on the head. If hardware must be replaced, be sure to replace it with hardware of equal size, strength & thread type. Refer to the torque values chart when tightening hardware.

The chart below is a guide for proper torque. Use it unless a specified torque is called out elsewhere in the manual. Torque is the force applied to the end of the handle or cheater bar, times the length of the handle or bar.

Use a torque wrench wherever possible

The following table shows torque in ft.-lbs. for coarse thread hardware.

Bolt Diameter and Threads per Inch	Grade 2	Grade 5	A-325	Grade 8
1/4	6	10	10	14
5/16	12	20	20	30
3/8 – 16	25	35	35	50
7/16 – 14	35	55	55	80
1/2 – 13	55	85	85	125
9/16 – 12	75	125	125	175
5/8 – 11	105	170	170	235
3/4 - 10	185	305	305	425
7/8 – 9	170	445	445	690
1 - 8	260	670	670	1030
1 1/8 – 7	365	900	900	1460
1 1/4 - 7	515	1275	1275	2060
1 3/8 – 6	675	1675	1675	2700
1 1/2 - 6	900	2150	2150	3500
1 3/4 – 5	1410	3500	3500	5600

INSTALLATION TOOLS REQUIRED:

- Pneumatic or electric impact driver
- 3/4 & 15/16 size sockets
- 10" impact driver extension
- Ratchet
- 3/4, 15/16, & 1 1/8 size wrenches
- 5/16 Allen Wrench
- Torque Wrench



5000-022C ASSEMBLY INSTRUCTIONS

(LEXION C512-30 / CAPELLO)

Note: Before starting installation, clean the corn head of debris, remove the guards, & lift the snouts.

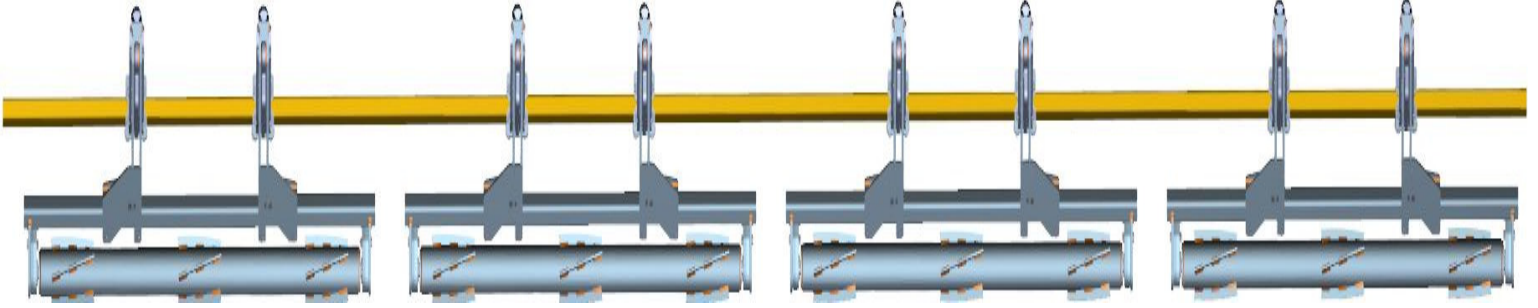

Step 1: Attach the 5000-250 mount brackets to the frame using the 4) 5/8 x 7" bolts, mounting straps, & 5/8 lock hex nuts. Mounting Brackets will be located under the snouts between rows 1 & 2, 2 & 3, 4 & 5, 5 & 6, 7 & 8, 8 & 9, 10 & 11, and 11 & 12. Slide the mount bracket up so the deck plate adjustment rod is located in the cut out of the mount bracket.

Note: Do not fully tighten hardware until **Step 6** after all of the pivot arms & springs are installed.

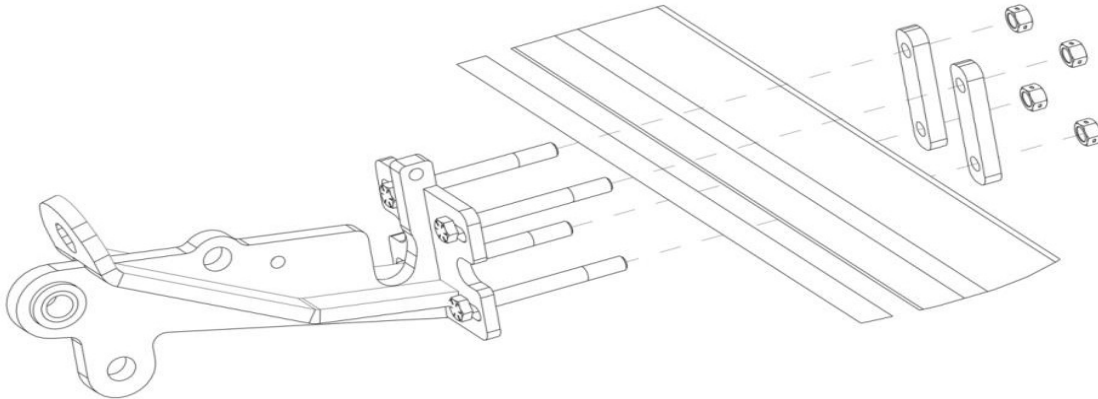

Arrows indicate 5000-250 mount bracket locations

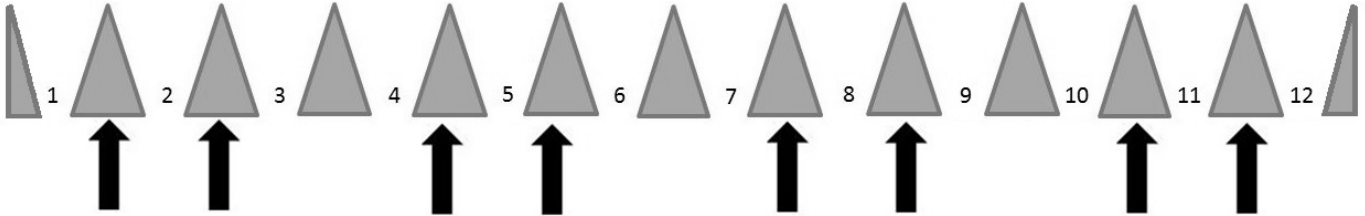

NOTE: NOTCHES NEED CUT IN THE GUARDS TO ALLOW THE MOUNTING BOLTS TO BE USED. CUT THESE NOTCHES AFTER THE COMPLETION OF THE DEVASTATOR INSTALLATION. IN SOME SITUATIONS, A HOLE MAY NEED DRILLED IN THE MOUNTING TAB FOR THE GUARDS. POSITION THE DECK PLATE ADJUSTER VERTICALLY TO HAVE CLEARANCE IN THE DEVASTATOR MOUNT OPENING.

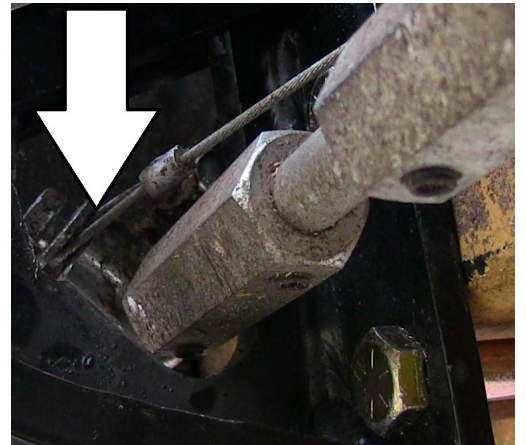
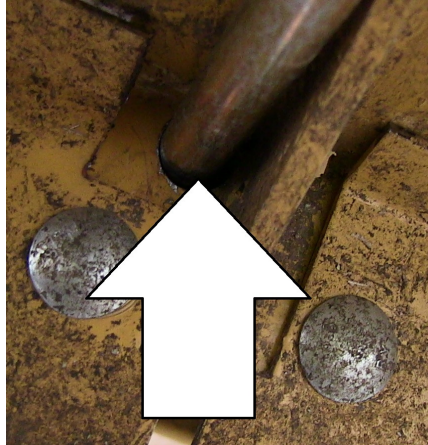
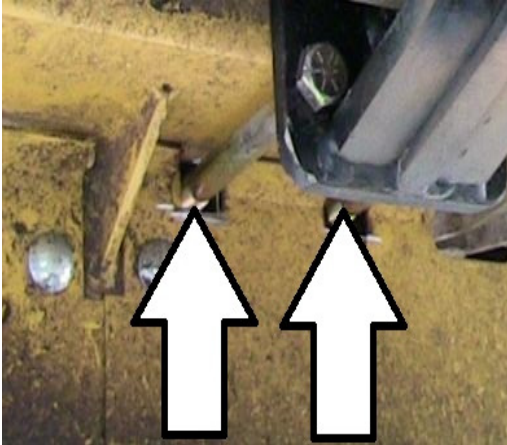

5000-022C ASSEMBLY INSTRUCTIONS

Step 2: Attach the 5000-309 support straps using the 1/2" x 2" carriage bolts & 1/2 flange lock nuts, tighten.

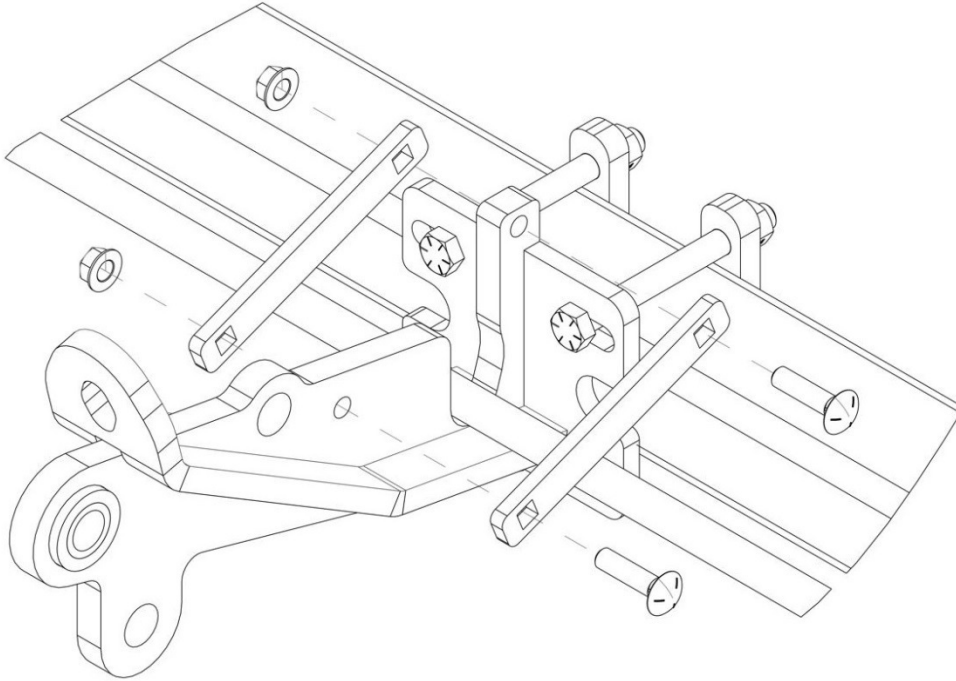

Step 3: Install the 5000-323 lock-up pin in the storage location on the mount brackets. Secure with the hairpin clips.

STORAGE LOCATION

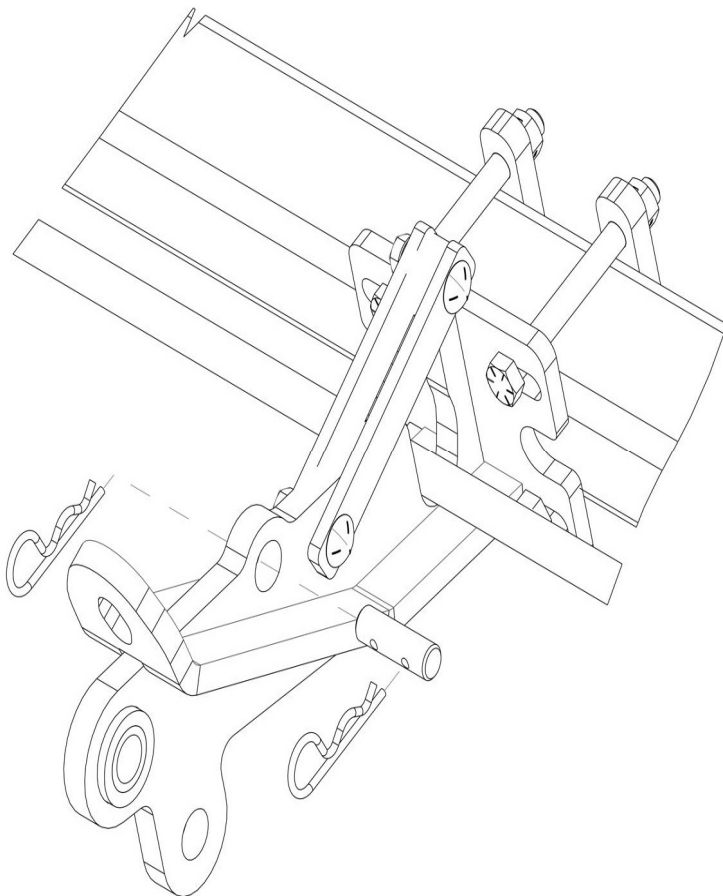

PINNED UP LOCATION

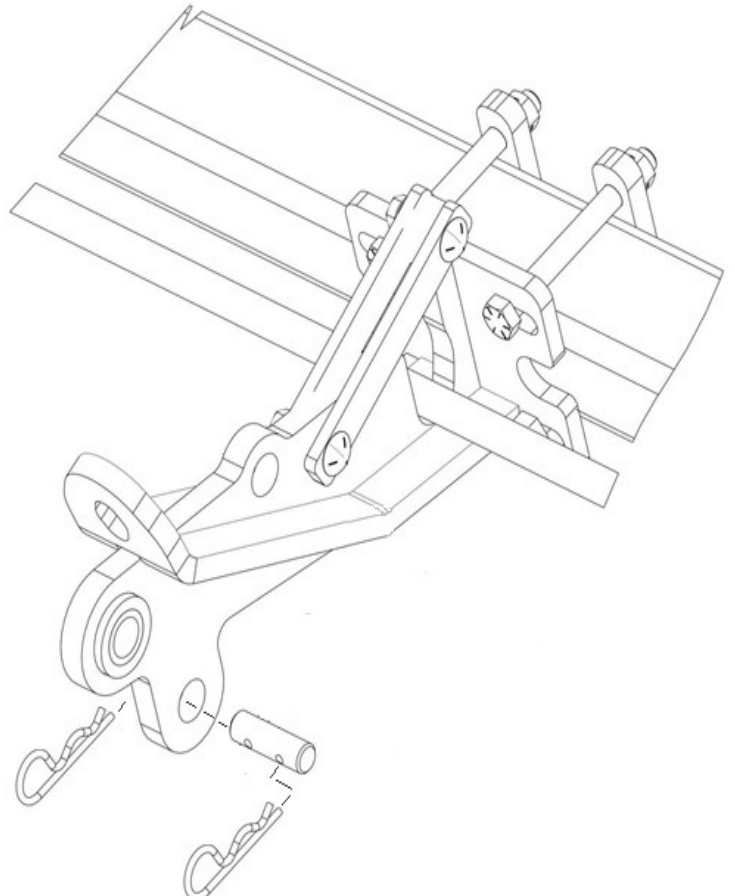

5000-022C ASSEMBLY INSTRUCTIONS

Step 4: Attach the pivot arms, using the lower of the 2 holes, to the mount brackets using the 5/8" X 3 bolts, pivot bushings, and lock hex nuts. Tighten this hardware.

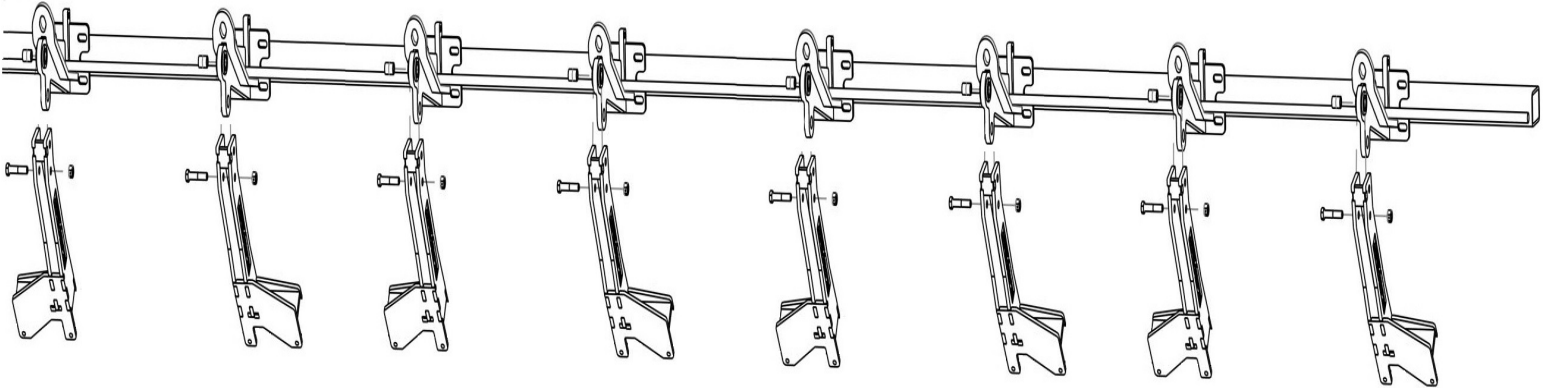

Step 5: Install the push rods into the mount brackets then attach to the pivot arms with the 5/8" shoulder bolts, washers, and 1/2" jam lock nuts.

Note: The washers are installed on each side of the "eye" of the push rod.

Now install the compression spring, spring bushing, and 3/4" lock hex nuts. Tighten the hardware from **Step 5** to the specification in the diagram below.

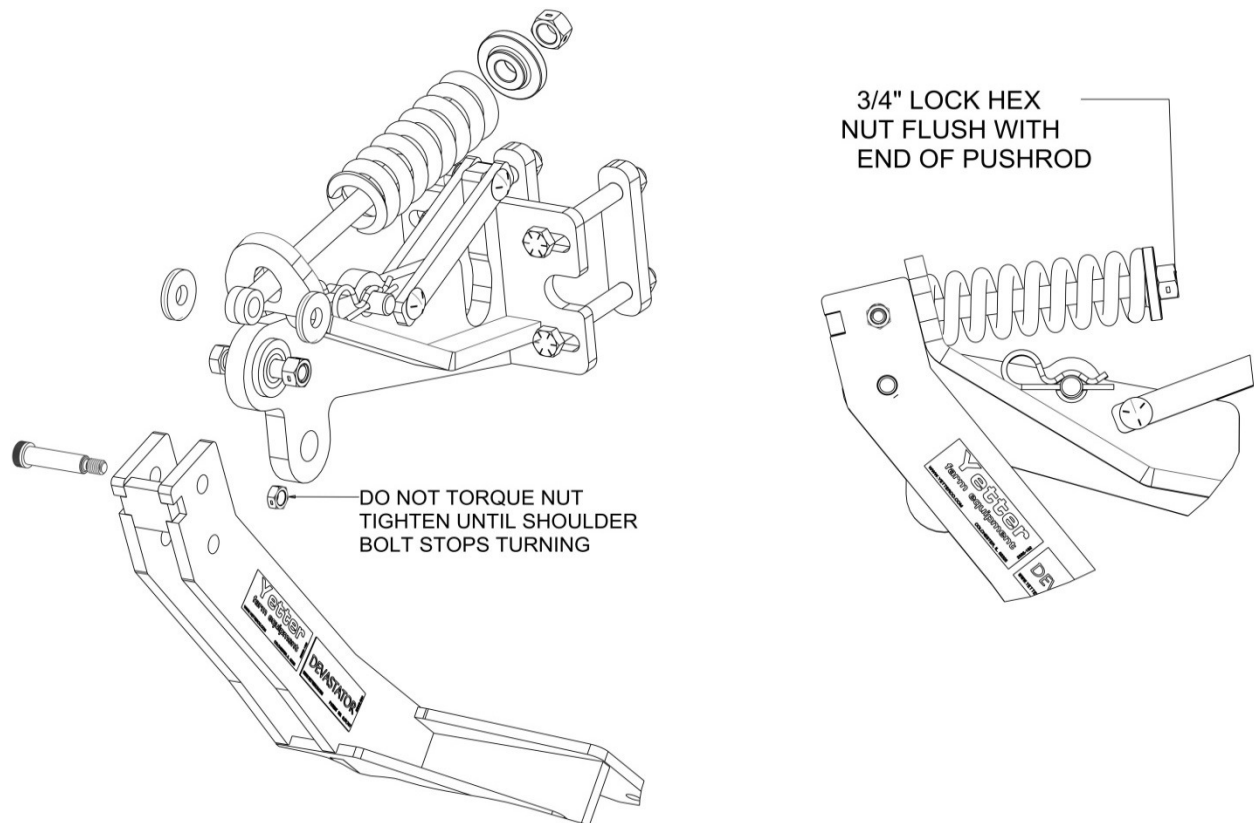

NOTE: Tightening the nut on the spring bushing more will result in added down pressure. However, DO NOT tighten the nut on the spring bushing down so far that spring compression limits pivot arm travel.

5000-022C ASSEMBLY INSTRUCTIONS

Step 6: Secure the mounting bracket installed in **Step 1** at this time by tightening the 5/8 X 7" bolts & 5/8 lock nuts. Make sure the compression spring clears the cylinder channel, gathering chains, & deck plate adjustment. The offset pivot arm clamp should be under the snout, not directly under the row.

Row 1 & 2

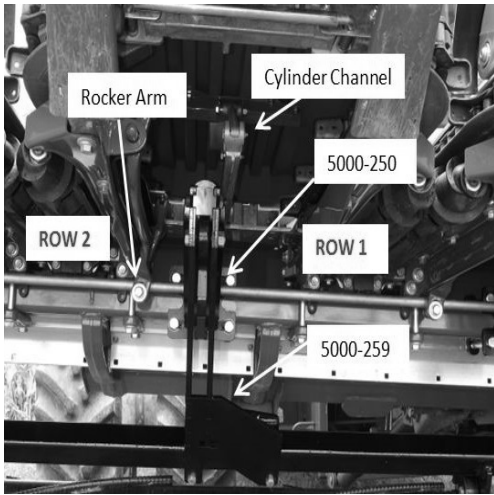

Row 2 & 3

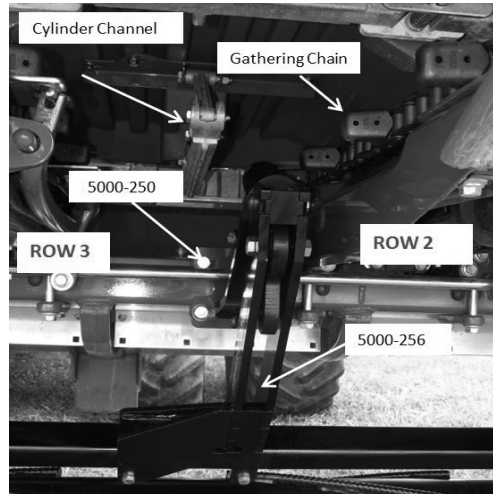

Row 4 & 5

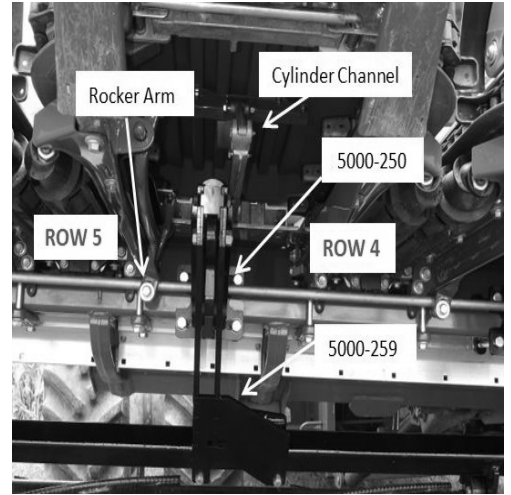

Row 5 & 6

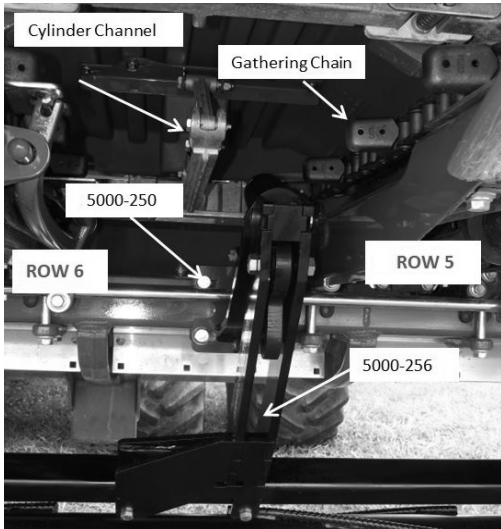

Row 7 & 8

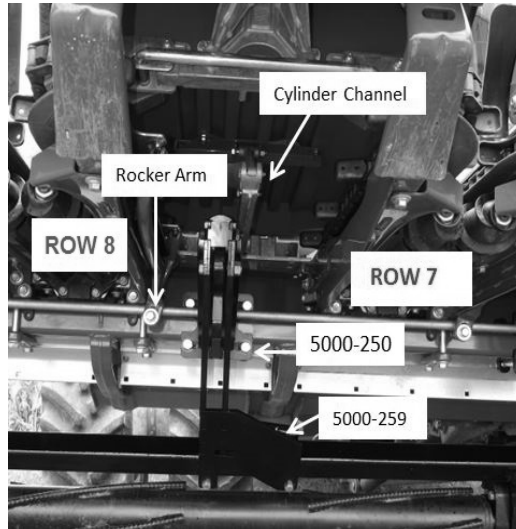

Row 8 & 9

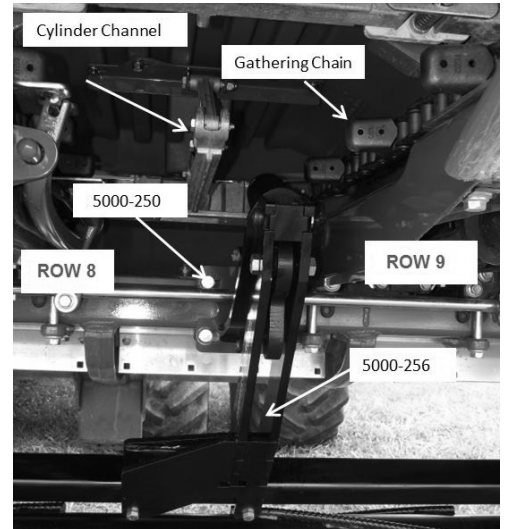

Row 10 & 11

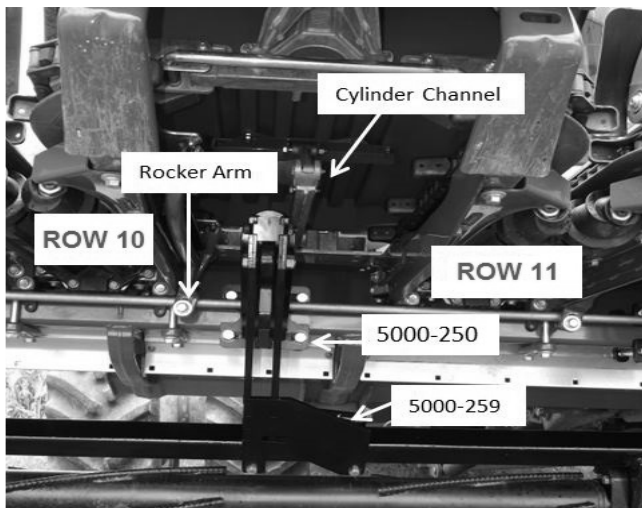

Row 11 & 12

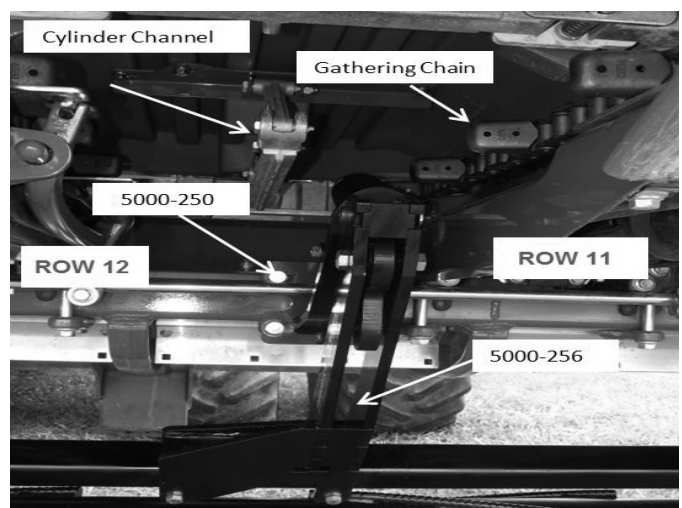

5000-022C ASSEMBLY INSTRUCTIONS

Step 7: Install the Roller Arm Mount Tube inside the clamp channel of the pivot arms using the 5000-138 bolt bag. Do not tighten this hardware until after the rollers have been installed in **Step 8**.

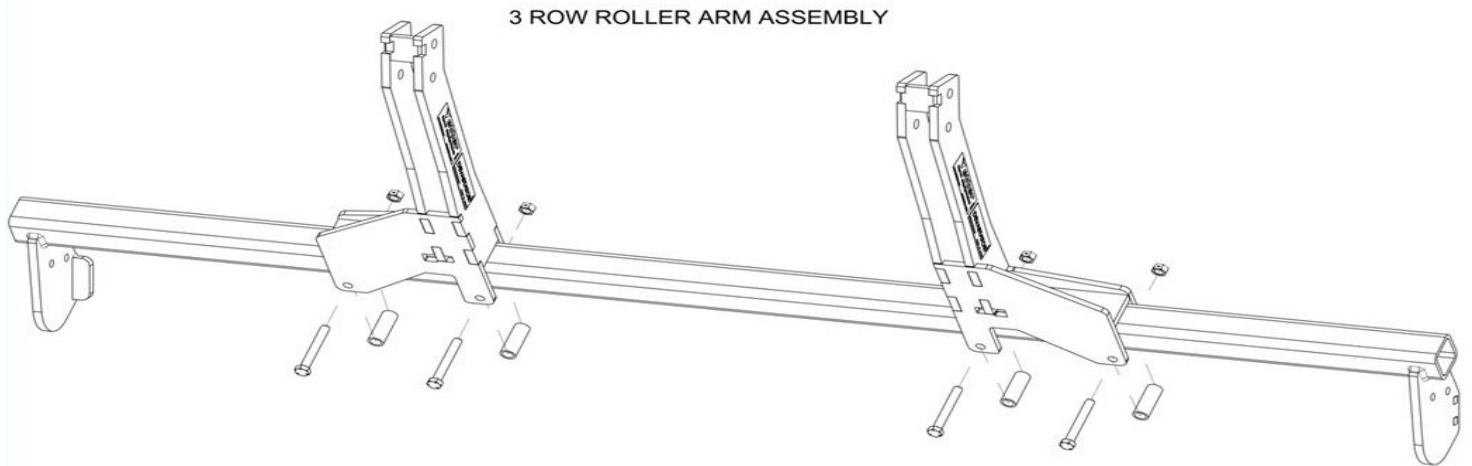

Step 8: Insert the shim washer over the shaft on each end of the roller. Install the bearing over the shaft on each end of the roller so that the side of the casting that has the bearing protruding past the housing surface is towards the roller barrel & shim washer. Lift each roller into place, install the $\frac{1}{2}$ " X $2 \frac{1}{2}$ " bolts & tighten the $\frac{1}{2}$ " lock nuts. Once the roller & bearing hardware is fastened, spin the roller to ensure the bearing was installed correctly. If the roller was installed incorrectly, the roller will not spin or will have drag. Slide the roller mount tube to gain clearance on each end of the corn head & then tighten the hardware.

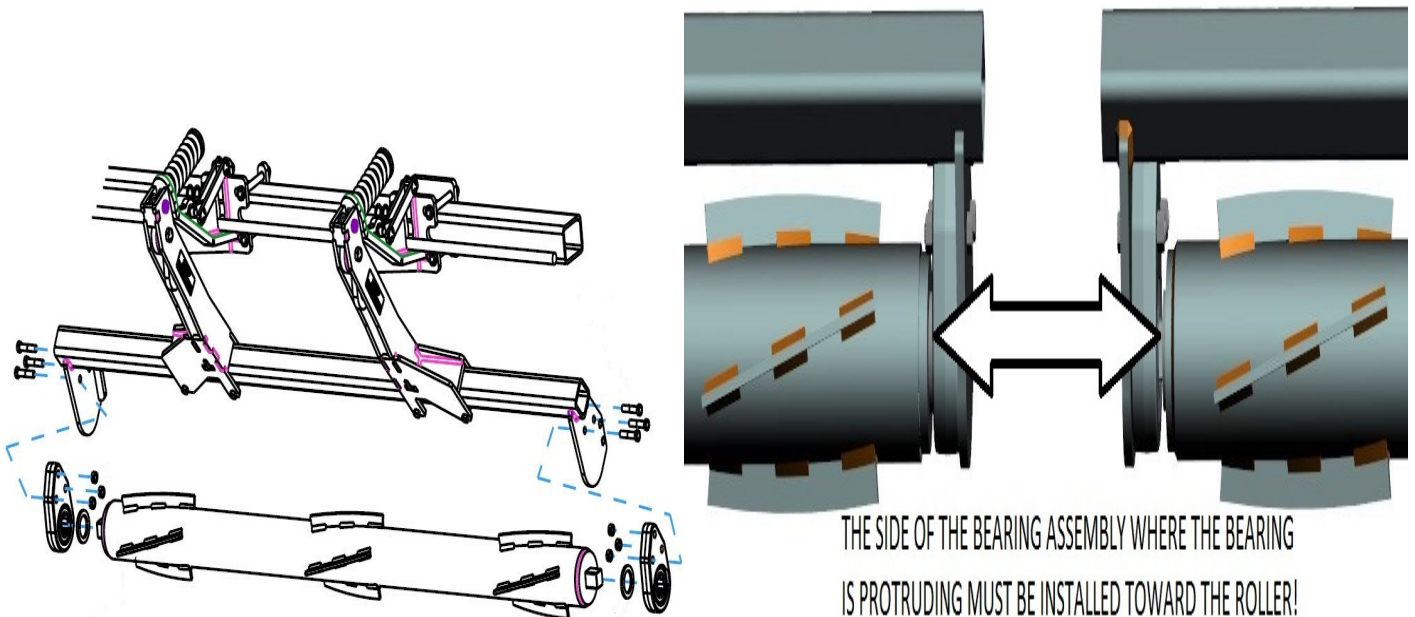

NOTE: BEARING HOUSING SHOULD BE LUBRICATED WITH POLYUREA GREASE BEFORE USE AND THEN EVERY 100 HOURS OF OPERATION



5000-033B ASSEMBLY INSTRUCTIONS

(LEXION C508-30 / CAPELLO)

Note: Before starting installation, clean the corn head of debris, remove the guards, & lift the snouts.

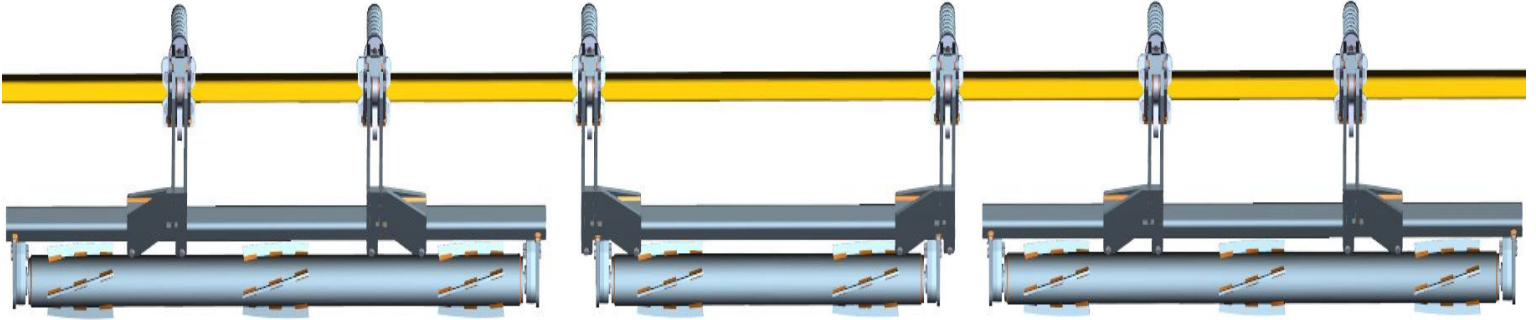

Step 1: Attach the 5000-250 mount brackets to the frame using the 5/8 x 7" bolts, mounting straps, & lock hex nuts. Mounting Brackets will be located under the snouts between rows 1 & 2, 2 & 3, 3 & 4, 5 & 6, 6 & 7, and 7 & 8. Slide the mount bracket up so the deck plate adjustment rod is located in the cut out of the mount bracket.

Note: Do not fully tighten hardware until **Step 6** after all of the pivot arms & springs are installed.

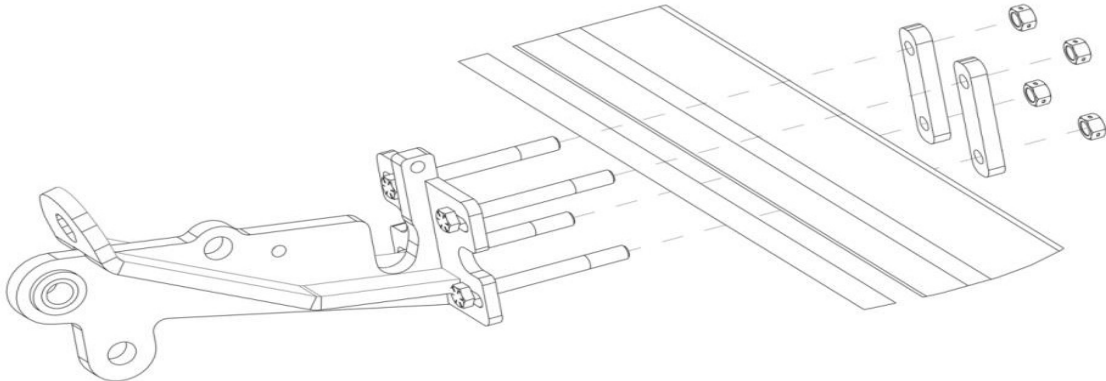

Arrows indicate 5000-250 mount bracket locations

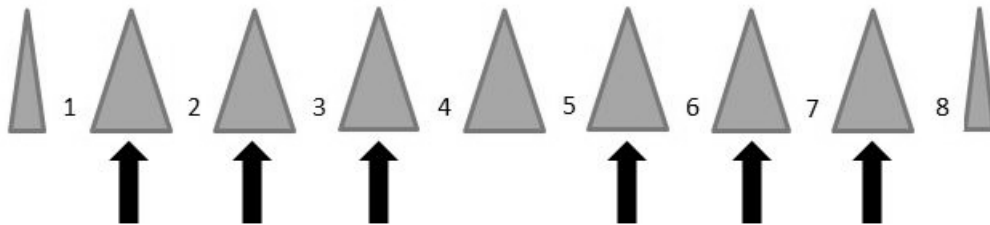

NOTE: NOTCHES NEED CUT IN THE GUARDS TO ALLOW THE MOUNTING BOLTS TO BE USED. CUT THESE NOTCHES AFTER THE COMPLETION OF THE DEVASTATOR INSTALLATION. IN SOME SITUATIONS, A HOLE MAY NEED DRILLED IN THE MOUNTING TAB FOR THE GUARDS. POSITION THE DECK PLATE ADJUSTER VERTICALLY TO HAVE CLEARANCE IN THE DEVASTATOR MOUNT OPENING.

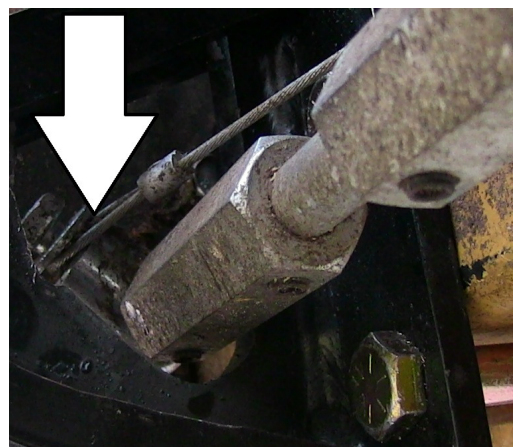

5000-033B ASSEMBLY INSTRUCTIONS

Step 2: Attach the 5000-309 support straps using the 1/2" x 2" carriage bolts & flange lock nuts, tighten.

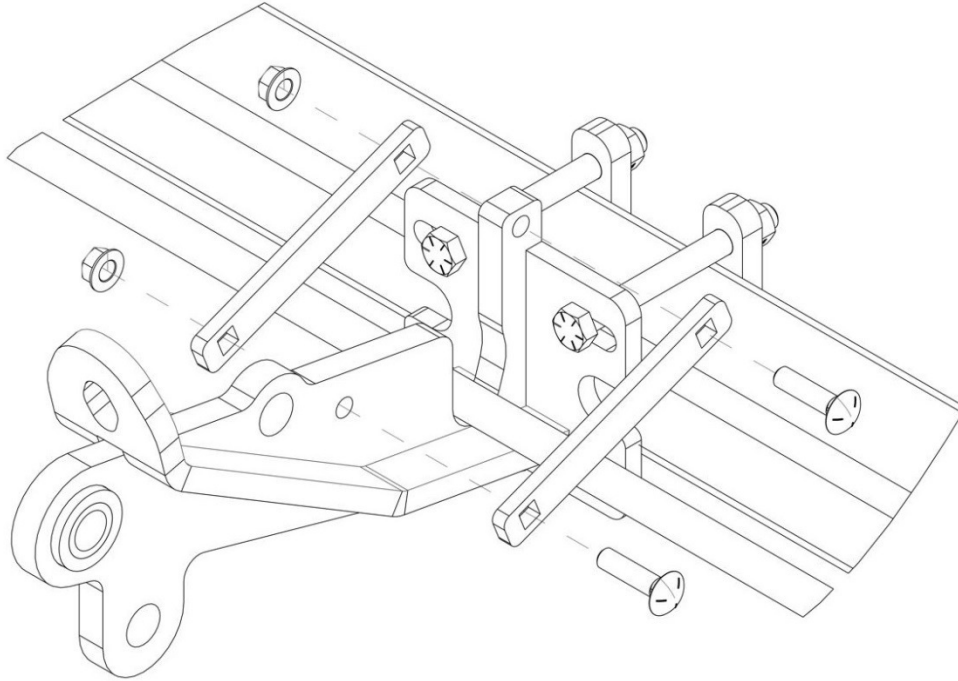

Step 3: Install the 5000-323 lock-up pin in the storage location on the mount brackets. Secure with the hairpin clips.

STORAGE LOCATION

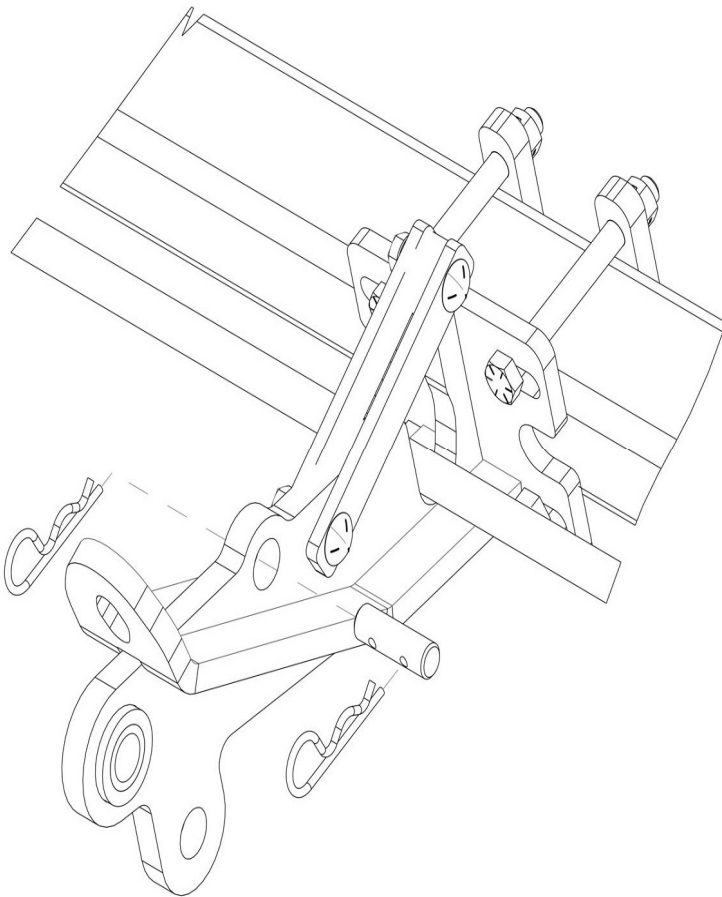

PINNED UP LOCATION

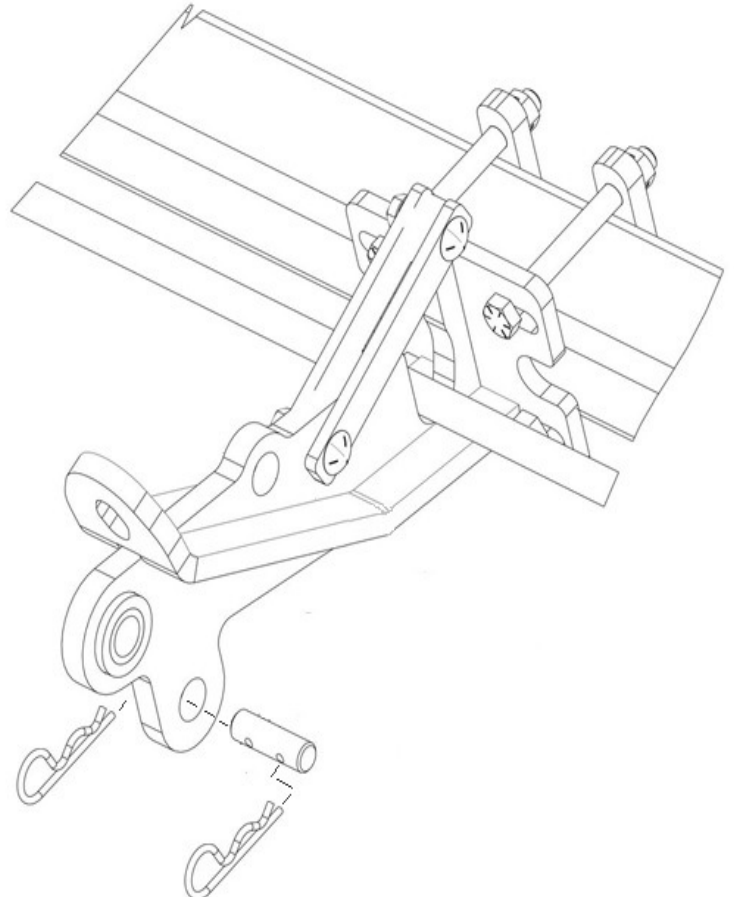

5000-033B ASSEMBLY INSTRUCTIONS

Step 4: Attach the pivot arms, using the lower of the 2 holes, to the mount brackets using the 5/8" X 3 bolts, pivot bushings, & lock hex nuts. Tighten this hardware.

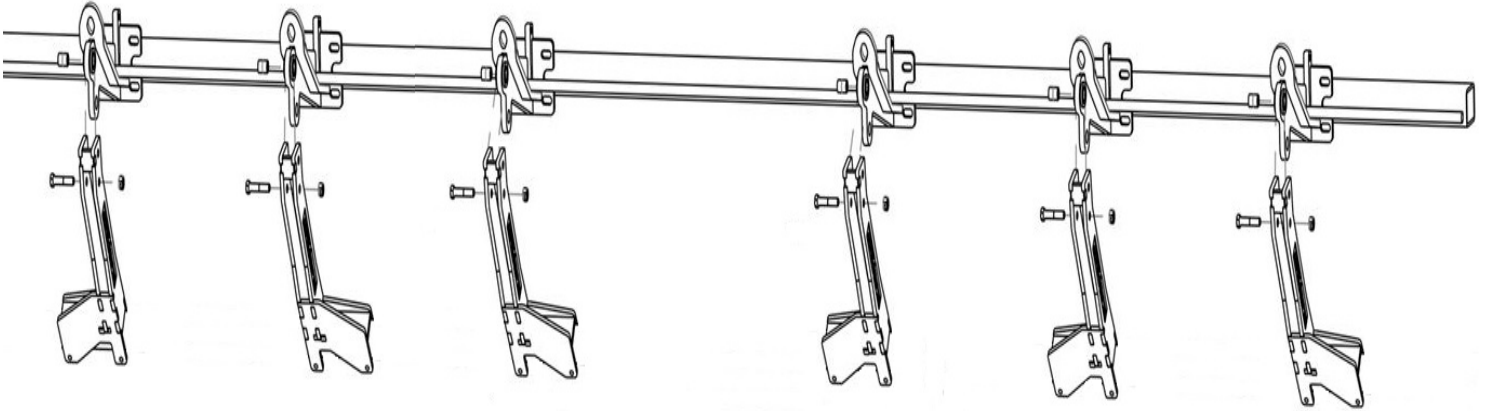

Step 5: Install the push rods into the mount brackets then attach to the pivot arms with the 5/8" shoulder bolts, washers, and 1/2" jam lock nuts.

Note: The washers are installed on each side of the "eye" of the push rod.

Now install the compression spring, spring bushing, and 3/4" lock hex nuts. Tighten the hardware from **Step 5** to the specification in the diagram below.

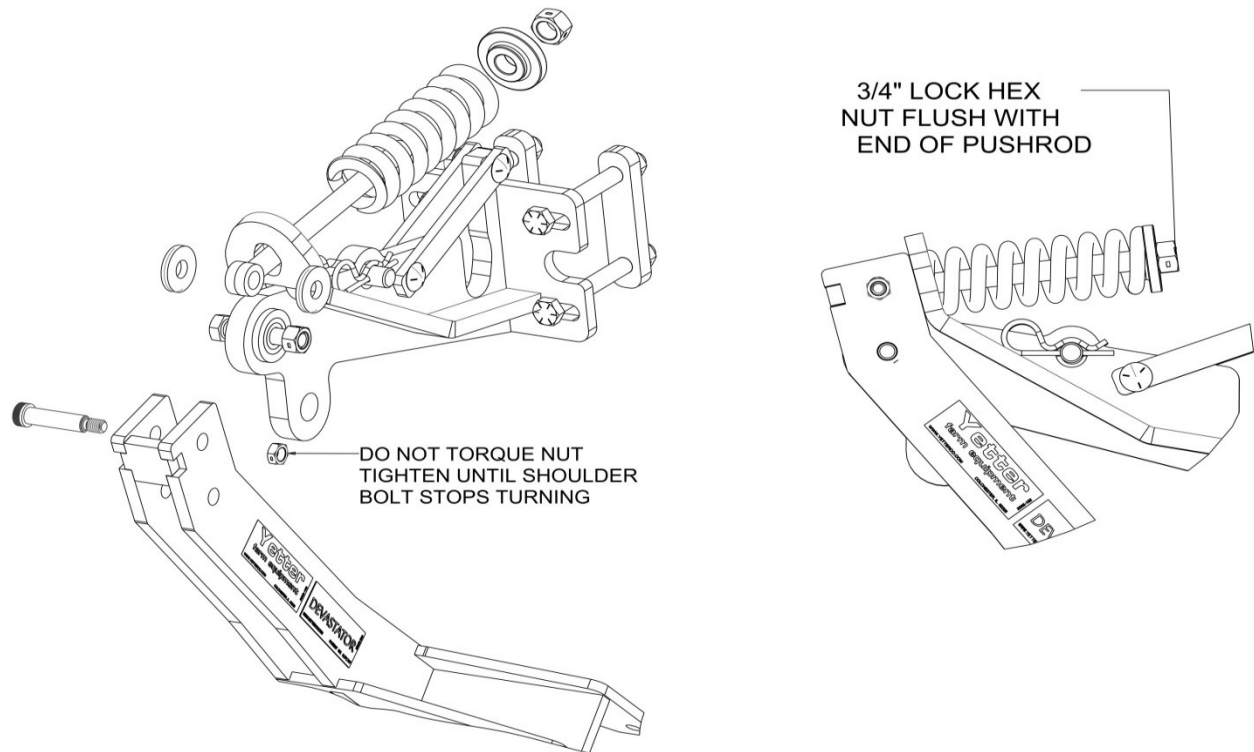

NOTE: Tightening the nut on the spring bushing more will result in added down pressure. However, DO NOT tighten the nut on the spring bushing down so far that spring compression limits pivot arm travel. This will cause the spring to break, especially if spring is compressed all off-season.

5000-033B ASSEMBLY INSTRUCTIONS

Step 6: Secure the mounting bracket installed in **Step 1** at this time by tightening the 5/8 X 7" bolts & 5/8 lock nuts. Make sure the compression spring clears the cylinder channel, gathering chains, & deck plate adjustment. The offset pivot arm clamp should be under the snout, not directly under the row.

Row 1 & 2

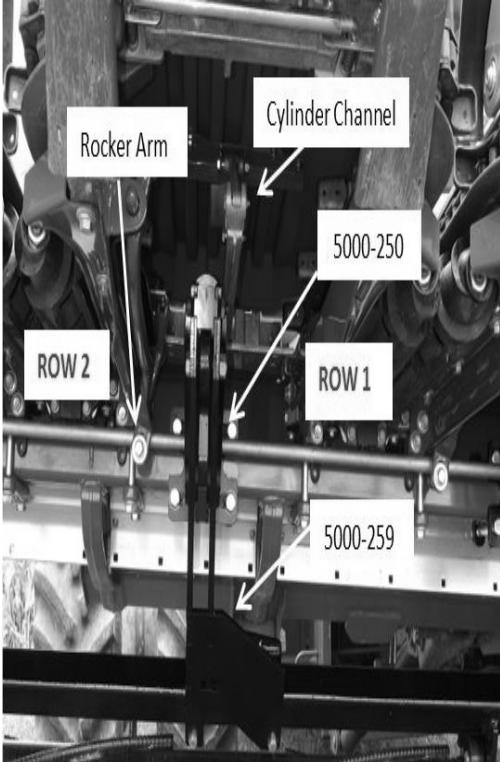

Row 2 & 3

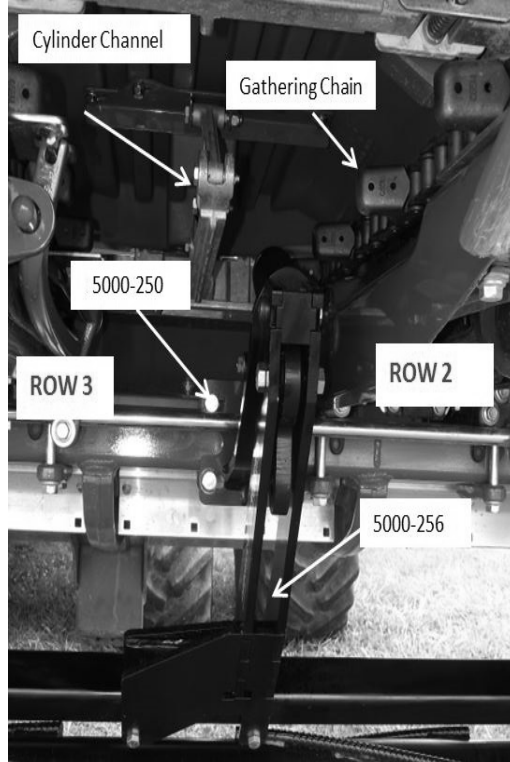

Row 3 & 4

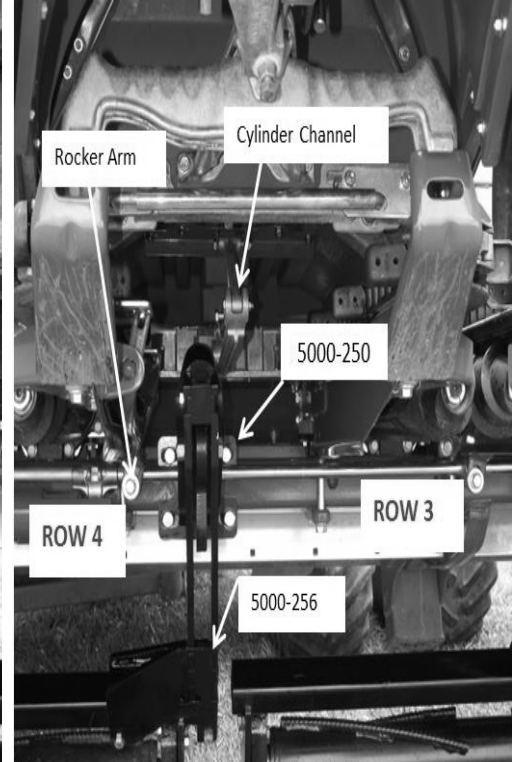

Row 5 & 6

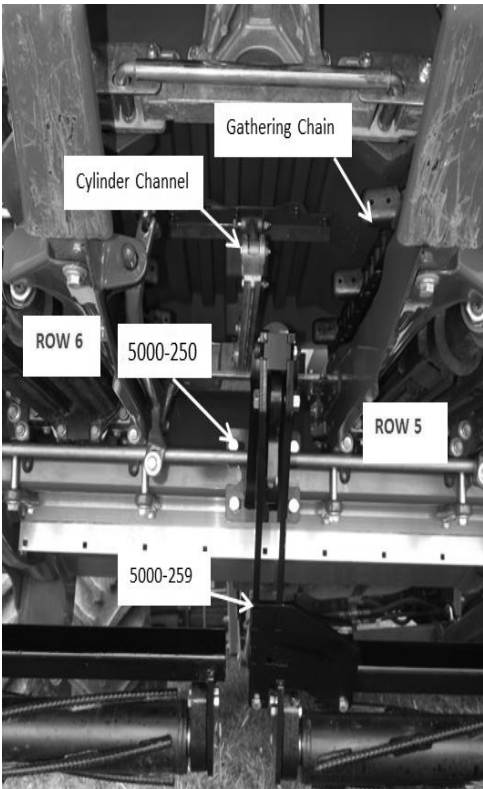

Row 6 & 7

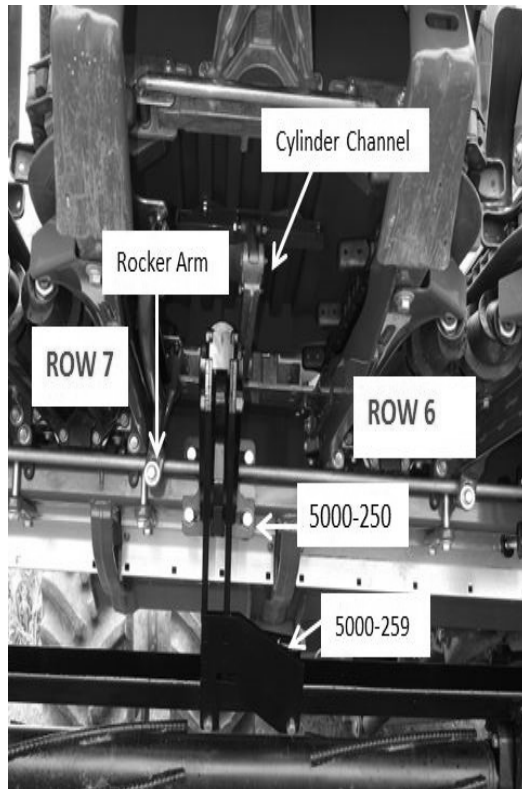

Row 7 & 8

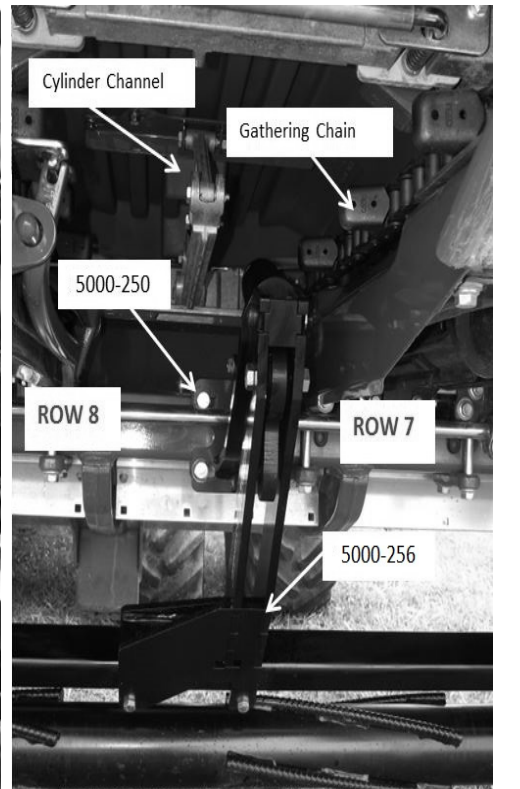

5000-033B ASSEMBLY INSTRUCTIONS

Step 7: Install the Roller Arm Mount Tube inside the clamp channel of the pivot arms using the 5000-138 bolt bag. Do not tighten this hardware until after the rollers have been installed in **Step 8**.

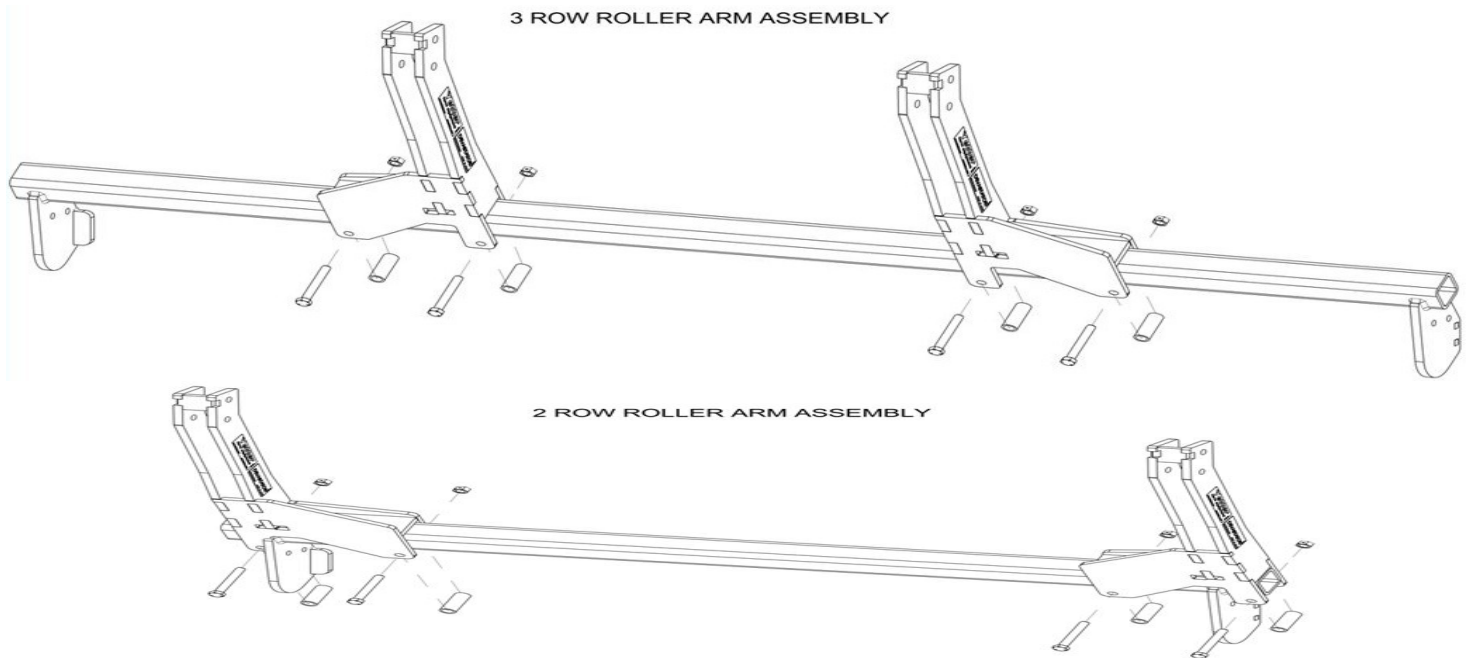

Step 8: Insert the shim washer over the shaft on each end of the roller. Install the bearing over the shaft on each end of the roller so that the side of the casting that has the bearing protruding past the housing surface is towards the roller barrel & shim washer. Lift each roller into place, install the $\frac{1}{2}$ " X $2 \frac{1}{2}$ " bolts & tighten the $\frac{1}{2}$ " lock nuts. Once the roller & bearing hardware is fastened, spin the roller to ensure the bearing was installed correctly. If the roller was installed incorrectly, the roller will not spin or will have drag. Slide the roller mount tube to gain clearance on each end of the corn head & then tighten the hardware.

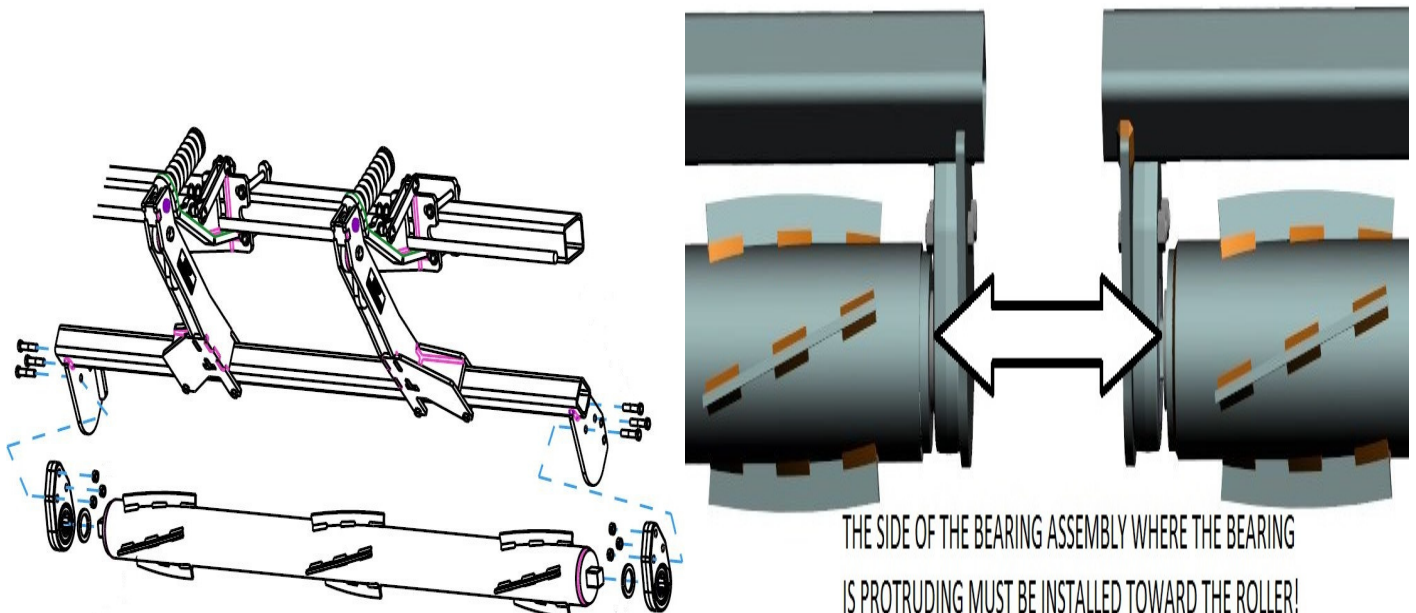

NOTE: BEARING HOUSING SHOULD BE LUBRICATED WITH POLYUREA GREASE BEFORE USE AND THEN EVERY 100 HOURS OF OPERATION



OPERATION

CORN HEAD ANGLE SHOULD BE BETWEEN 23 – 25° FOR OPTIMUM DEVASTATOR PERFORMANCE.

USE THE 5000-455 TO CHECK CORN HEAD ANGLE:

- Put the combine on a level surface. Lower the Corn head to your normal working head height.
- Place the magnetic protractor on the stripper plate to get the angle. Adjust the feeder house as needed, fore or aft, to achieve 23 – 25 degrees.



BEARING REPLACEMENT

Put the bearing housing in a vice, use a pry bar to turn the bearing in the housing parallel with the slots, remove the old bearing, apply anti-seize lubricant to the interior of the bearing housing, insert the new bearing in the slots, & use a pry bar to move back to position. Wobble the bearing around to help work the lubricant into the outer race of the bearing.



STORAGE

When storing the corn head for the offseason, it is OK for the 5000 Stalk Devastators to hold some weight of the corn head whether stored on the ground or on a trailer. Removing compression springs may help extend the service life.

LOCKING UP THE 5000 SERIES STALK DEVASTATOR

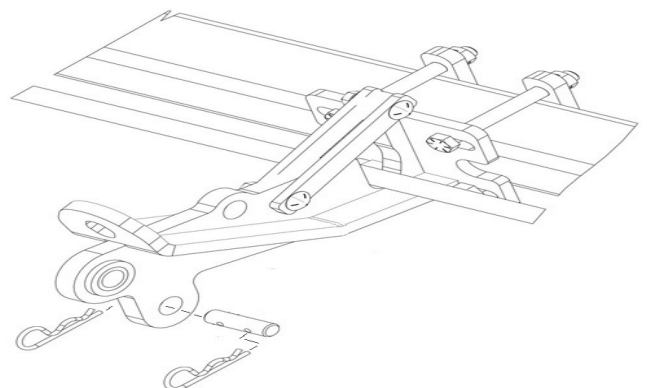

5000-022C PARTS IDENTIFICATION

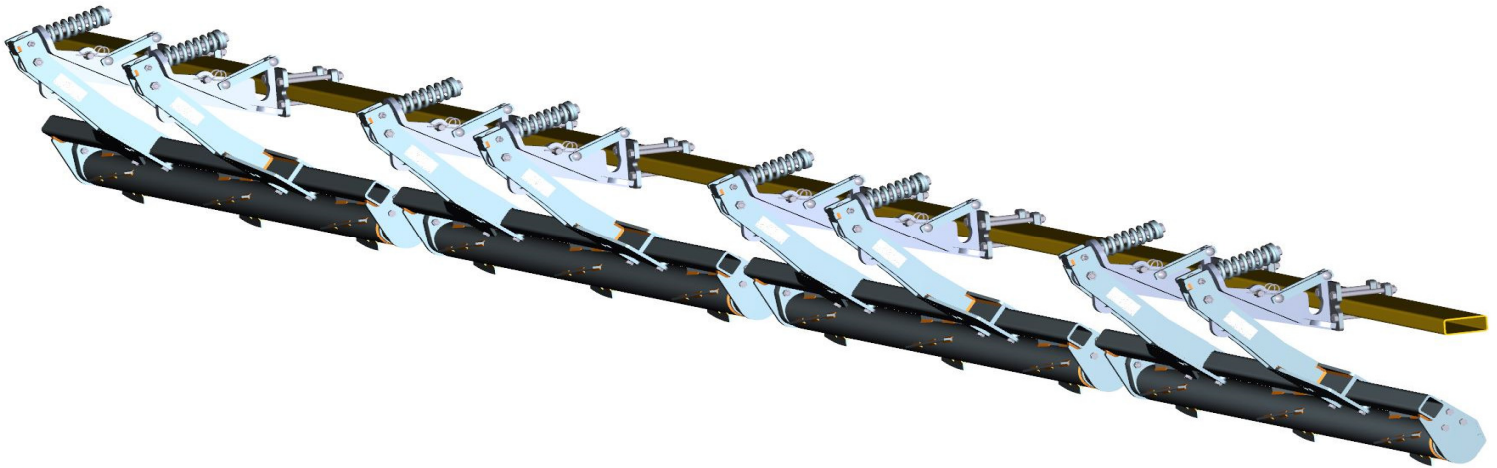

ITEM	PART #	DESCRIPTION	QTY
1	2502-325	5/8" – 11 X 3" CAP SCREW GRADE 5	8
2	2502-353	1/2" – 13 X 2 1/2" CAP SCREW GRADE 8	24
3	2502-365	1/2 - 13 X 3 3/4 CAP SCREW GRADE 5	16
4	2502-396	5/8 – 11 X 7 CAP SCREW GRADE 8	32
5	2505-345	1/2 - 13 X 2 CARRIAGE BOLT GRADE 5	16
6	2510-121	5/8" DIAMETER SHOULDER X 2 1/4" WITH THREAD 1/2 -13	8
7	2520-361	1/2 - 13 FLANGE WHIZLOCK HEX NUT GRADE 5	16
8	2520-362	1/2-13 LOCK HEX NUT GRADE 8	40
9	2520-364	1/2 - 13 HEX LOCK NUT	8
10	2520-459	5/8 – 11 LOCK HEX NUT GRADE 5	8
11	2520-515	3/4 - 10 LOCK HEX NUT GRADE 2	8
12	2520-603	5/8-11 TOP LOCK HEX NUT GRADE 8	32
13	2526-449	5/8 FLAT WASHER, 1/4 THICK	16
14	2526-451	5/8 STANDARD FLAT WASHER	32
15	2550-709	1/2 WIRE 2 1/2 OD X 1 1/2 ID X 7 1/4 COMPRESSION SPRING	8
16	2570-126	3/4 X 10 EYEBOLT	8
17	2570-465	HAIRPIN COTTER	16
18	2975-302	SPRING BUSHING	8
19	5000-250	MOUNTING WELDMENT – LEXION	8
20	5000-256	LEFT HAND ARM 19"	4
21	5000-259	RIGHT HAND ARM 19"	4
22	5000-272	3R30 ROLLER 71.5"	4
23	5000-275A	3R30 ROLLER MOUNT 75.375"	4
24	5000-309	SUPPORT STRAP	16
25	5000-318	PIVOT BUSHING	8
26	5000-322	SHIM WASHER	8
27	5000-323	LOCK UP PIN	8
28	5000-355	BEARING ASSEMBLY	8
	2550-059	DEVASTATOR BEARING ONLY (NO CAST HOUSING)	8
29	5000-373	MOUNTING PLATE, 3" STRAP	16
30	5000-378	SPACER BUSHING	16

5000-022C PARTS IDENTIFICATION

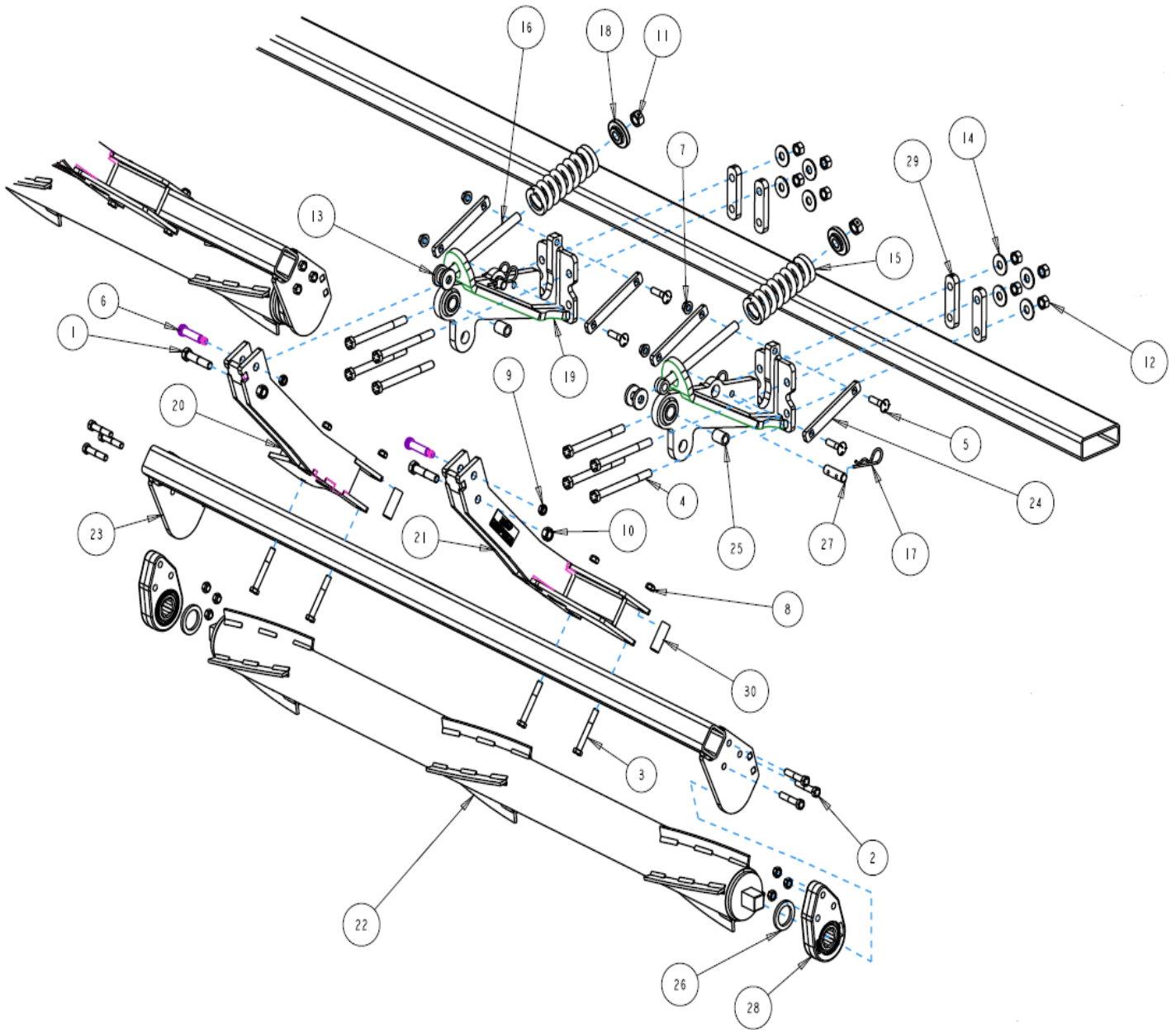

5000-033B PARTS IDENTIFICATION

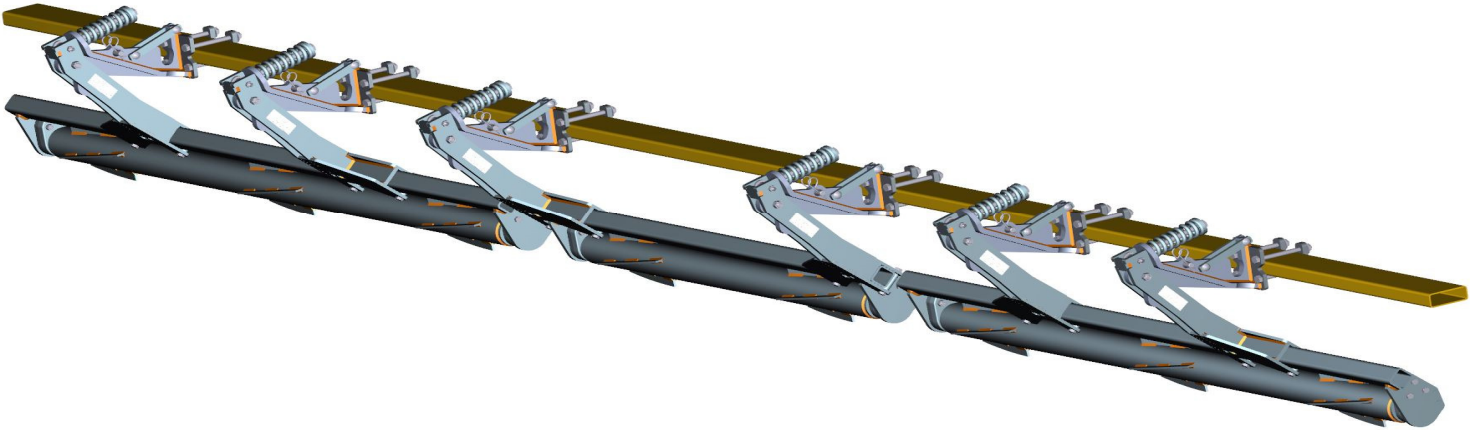

ITEM	PART #	DESCRIPTION	QTY
1	2502-325	5/8 – 11 X 3 CAP SCREW GRADE 5	6
2	2502-353	1/2 - 13 X 2 1/2 CAP SCREW GRADE 8	18
3	2502-365	1/2 - 13 X 3 3/4 CAP SCREW GRADE 5	12
4	2502-396	5/8 – 11 X 7 CAP SCREW GRADE 8	24
5	2505-345	1/2 - 13 X 2 CARRIAGE BOLT GRADE 5	12
6	2510-121	5/8" DIAMETER X 2 1/4" LONG SHOULDER, THREAD 1/2 -13	6
7	2520-361	1/2 - 13 FLANGE WHIZLOCK HEX NUT, GRADE 5	12
8	2520-362	1/2-13 LOCK HEX NUT GRADE 8	30
9	2520-364	1/2 - 13 HEX LOCK NUT	6
10	2520-459	5/8 – 11 LOCK HEX NUT, GRADE 5	6
11	2520-515	3/4 - 10 LOCK HEX NUT, GRADE 2	6
12	2520-603	5/8-11 TOP LOCK HEX NUT GRADE 8	24
13	2526-449	5/8 FLAT WASHER, 1/4 THICK	12
14	2526-451	5/8 STANDARD FLAT WASHER	24
15	2550-709	1/2 WIRE 2 1/2 OD X 1 1/2 ID X 7 1/4 COMPRESSION SPRING	6
16	2570-126	3/4 X 10 EYEBOLT	6
17	2570-465	HAIRPIN COTTER	12
18	2975-302	SPRING BUSHING	6
19	5000-203B	ROLLER 48"	1
20	5000-250	MOUNT- LEXION	6
21	5000-255	ROLLER MOUNT	1
22	5000-256	LEFT HAND ARM 19"	3
23	5000-259	RIGHT HAND ARM 19"	3
24	5000-272	3R30 ROLLER 71.5"	2
25	5000-275A	3R30 ROLLER MOUNT 75.375"	2
26	5000-309	SUPPORT STRAP	12
27	5000-318	PIVOT BUSHING	6
28	5000-322	SHIM WASHER	6
29	5000-323	LOCK UP PIN	6
30	5000-355	BEAING ASSEMBLY	6
	2550-059	DEVASTATOR BEARING ONLY (NO CAST HOUSING)	6
31	5000-373	MOUNTING PLATE, 3" STRAP	12
32	5000-378	SPACER BUSHING	12

5000-033B PARTS IDENTIFICATION

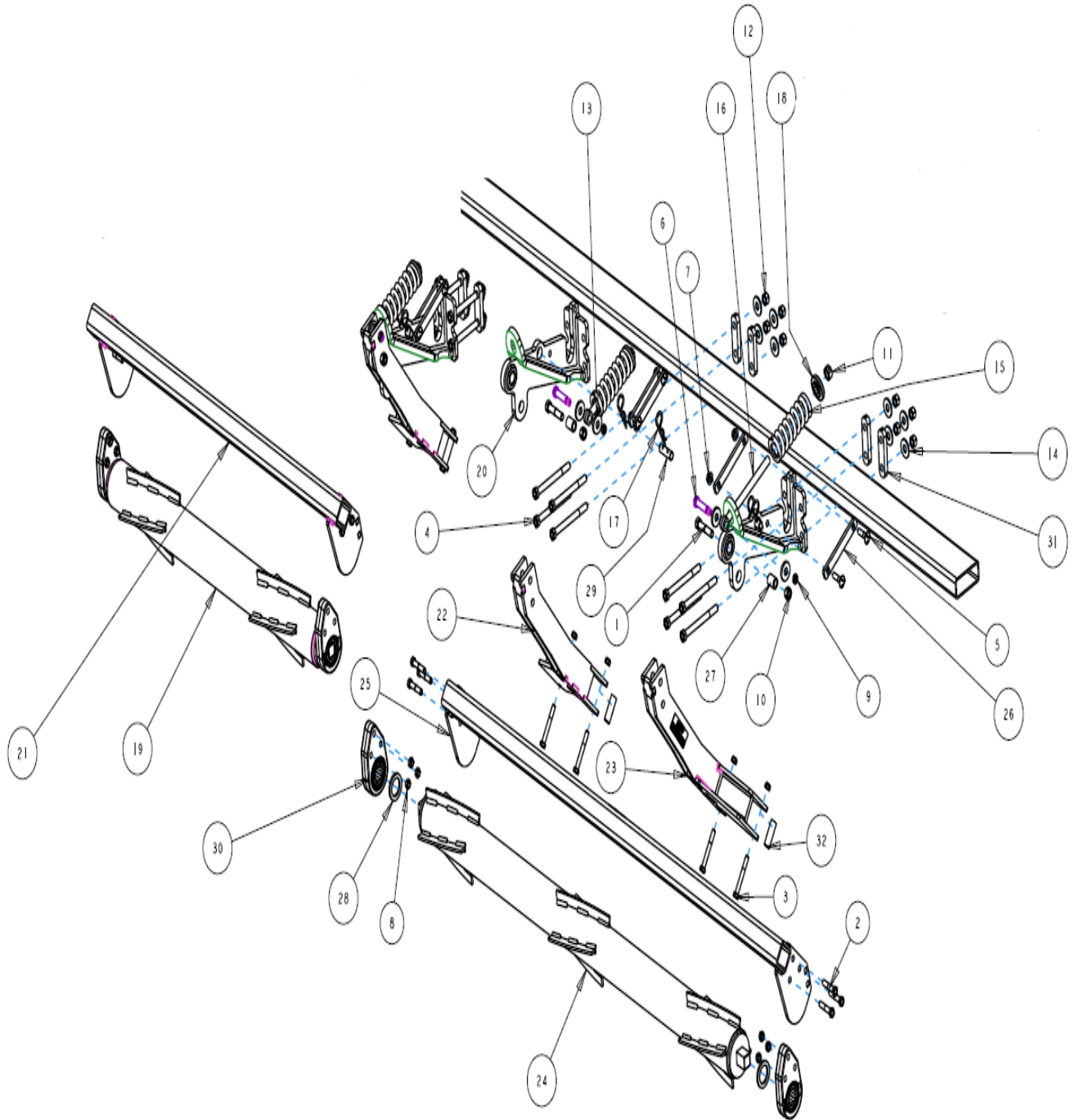

TROUBLESHOOTING

ISSUE	CAUSE	CORRECTIVE ACTION
Residue Plugging	<ol style="list-style-type: none"> 1. Incorrect Head Angle 2. Roller Mount Tube incorrectly installed 3. Pivot arm orientation incorrect 4. Bearing installed incorrectly 5. Intermeshing snapping rolls 6. Too much Spring Tension 	<ol style="list-style-type: none"> 1. Adjust head angle to 23 – 25 degrees 2. Make sure the Bearing Support Tab is on the backside of the Roller Mount Tube 3. Reposition the pivot arm so that it offsets under the snout & not under the row 4. Make sure the side of the bearing that protrudes outside of the cast housing is facing toward the roller (each roller should spin freely by hand) 5. Order the 5000-080 Set Back Kit (order 2 per roller) 6. Back the nut off of the push rod until the nut is flush
Stalk aren't "devastated"	<ol style="list-style-type: none"> 1. Insufficient spring down pressure 2. Operating corn head too high 	<ol style="list-style-type: none"> 1. Tighten push rod nut on spring bushing more 2. Lower corn head until the rollers engage
Corn Head won't fit on head cart	<ol style="list-style-type: none"> 1. Devastators bottom out 2. Roller won't clear cart tire 3. Header parking stand not touching the head cart saddle 	<ol style="list-style-type: none"> 1. Adjust top rail & saddles higher on cart 2. Order 5000-082 Lift Kit (raises roller 2") 3. Slide the header parking stand down until contact with head cart saddle is made.







A Tradition of Solutions since 1930

Yetter Farm Equipment Co

PO BOX 358 109 S. McDonough

Colchester, IL 62326-0358

Phone: 309-776-4111

Toll Free: 800-447-5777

Email: info@yetterco.com

For updated models and manuals visit the Yetter website:

www.yetterco.com

© Yetter Farm Equipment Co. All Rights Reserved

2565-783_REV_D • 02/2024