



5000 SERIES STALK DEVASTATOR CORN STALK ROLLER

PATENTED

OPERATOR'S MANUAL

PART IDENTIFICATION

2565-771_REV_I – 01/2024

5000-005B – 5000-021C, 5000-031C, 5000-037



YETTER MANUFACTURING CO.
FOUNDED 1930

Colchester, IL 62326-0358

Toll free: 800/447-5777

309/776-3222 (Fax)

Website: www.yetterco.com

E-mail: info@yetterco.com

YETTER

FOREWORD

You've just joined an exclusive but rapidly growing club.

For our part, we want to welcome you to the group and thank you for buying a Yetter product.

We hope your new Yetter products will help you achieve both goals-increase your productivity and increase your efficiency so that you may generate more profit.

This operator's manual has been designed into four major sections: Foreword, Safety Precautions, Installation Instructions and Parts Breakdown.



This **SAFETY ALERT SYMBOL** indicates important safety messages in the manual. When you see this symbol, be alert to the possibility of **PERSONAL INJURY** and carefully read the message that follows.

The word **NOTE** is used to convey information that is out of context with the manual text. It contains special information such as specifications, techniques and reference information of a supplementary nature.

The word **IMPORTANT** is used in the text when immediate damage will occur to the machine due

to improper technique or operation. Important will apply to the same information as specified by note only of an immediate and urgent nature.

It is the responsibility of the user to read the operator's manual and comply with the safe and correct operating procedure and to lubricate and maintain the product according to the maintenance schedule in the operator's manual.

The user is responsible for inspecting his machine and for having parts repaired or replaced when continued use of the product would cause damage or excessive wear to the other parts.

It is the user's responsibility to deliver his machine to the Yetter dealer who sold him the product for service or replacement of defective parts, which are covered by the warranty policy.

If you are unable to understand or follow the instructions provided in this publication, consult your local Yetter dealer or contact:

YETTER MANUFACTURING CO.

309/776-4111

800/447-5777

309/776-3222 (FAX)

Website: www.yetterco.com

E-mail: info@yetterco.com

WARRANTY

Yetter Manufacturing warrants all products manufactured and sold by it against defects in material. This warranty being expressly limited to replacement at the factory of such parts or products as shall appear to be defective after inspection. This warranty does not obligate the Company to bear cost of labor in replacement of parts. It is the policy of the Company to make improvements without incurring obligations to add them to any unit already sold. No warranty is made or authorized to be made, other than herein set forth. This warranty is in effect for one year after purchase.

DEALER: _____

Yetter Manufacturing warrants its own products only and cannot be responsible for damages to equipment on which mounted.



BE ALERT! YOUR SAFETY IS INVOLVED.



WATCH FOR THIS SYMBOL. IT POINTS OUT IMPORTANT SAFETY PRECAUTIONS. IT MEANS “ATTENTION---BECOME ALERT!”

It is your responsibility as an owner, operator, or supervisor to know and instruct everyone using this machine at the time of initial assignment and at least annually thereafter, of the proper operation, precautions, and work hazards which exist in the operation of the machine in accordance with OSHA regulations.

Safety Is No Accident

The following safety instructions, combined with common sense, will save your equipment from needless damage and the operator from unnecessary exposure to personal hazard. Pay special attention to the caution notes in the text. Review this manual at least once each year with new and/or experienced operators. Use proper personal protection equipment during this installation.



1. Read and understand the operator's manual before operating this machine. Failure to do so is considered a misuse of the equipment.
2. Make sure equipment is secure before operating.
3. Always keep children away from equipment when operating.
4. Make sure everyone that is not directly involved with the operation is out of the work area before beginning the operation.
5. Make sure all safety devices, shields, and guards are in place and are functional before beginning the operation.
6. Shut off power to adjust, service, or clean.
7. Keep hands, feet, and clothing away from moving parts. It is a good idea to remove all jewelry before starting the operation.
8. Visually inspect the machine periodically during operation for signs of excessive vibration, loose fasteners, and unusual noises.

PLEASE READ, VERY IMPORTANT



SECURE CORN HEADER AGAINST UNWANTED LOWERING BY APPLYING THE LOCKING MECHANISM ON THE HYDRAULIC CYLINDERS!



1. Attach head to combine, lock head to combine
2. Raise the head off the ground and engage safety stop on the feeder house cylinder.
3. Turn off combine engine and remove the key

Subject to the size and weight of the corn header, one or two additional hydraulic cylinders may be required.

The combine manufacturer generally keeps corresponding kits readily available for dealers.

Subject to the design of the corn header and the carrying capacity of different combines, the steering axle may require the fitting of additional weights and the rear tires be filled with ballast.

Modifications to the corn head may be needed.

Head Cart adjustments or modifications may be needed to set head on the cart properly.

FOLLOW ALL INSTRUCTIONS GIVEN BY THE COMBINE MANUFACTURER

TABLE OF CONTENTS

INTRODUCTION / WARRANTY2
 SAFETY INFORMATION.....3 – 4
 TABLE OF CONTENTS.....5
 OPERATION.....6
 TORQUE / TOOLS REQUIRED.....7
 INSTALLATION / PARTS IDENTIFICATION
 5000-005B (CNH 3206/3406/NH98D)..... 8 - 9
 5000-006C (CNH 3208/3408/NH98D).....10 - 11
 5000-007D (DRAGO 630).....12 - 13
 5000-009C (CNH 2206/NH96C/996).....14 – 15
 5000-010C (CNH 2208/2408/NH96C/996).....16 – 17
 5000-013B (CNH 1063).....18 – 19
 5000-014C (CNH 1083).....20 – 21
 5000-015C (GERINGHOFF 8 ROW).....22 – 23
 5000-016C (GERINGHOFF 12 ROW).....24 – 25
 GERINGHOFF HYDR. CYLINDER RELOCATION..... 38
 5000-017D (DRAGO 830).....26 – 27
 5000-018D (DRAGO 1230).....28 – 29
 5000-019C (CNH 2412/3412NH98C/996).....30 – 31
 5000-021C (GERNINGHOFF 6-ROW).....32 – 33
 5000-031C (FANTINI 8 ROW).....34 – 35
 5000-037 (8 ROW FOLDING GERINGHOFF)36 – 37
 TROUBLESHOOTING..... 39



Make sure the Bearing Support Tab is on the backside of the Roller Mount Plate on each Roller Mount Tube when assembling.

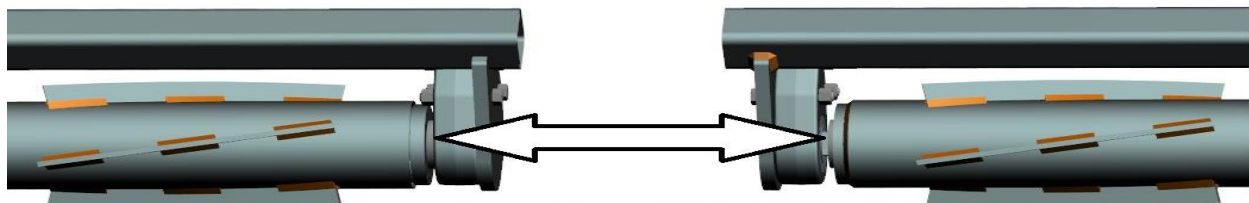

THE SIDE OF THE BEARING ASSEMBLY WHERE THE BEARING IS PROTRUDING MUST BE INSTALLED TOWARD THE ROLLER!

OPERATION

CORN HEAD ANGLE SHOULD BE BETWEEN 23 – 25° FOR OPTIMUM DEVASTATOR PERFORMANCE.



USE THE 5000-455 TO CHECK CORN HEAD ANGLE:

- Put the combine on a level surface. Lower the Corn head to your normal working head height.
- Place the magnetic protractor on the stripper plate to get the angle. Adjust the feeder house as needed, fore or aft, to achieve 23 – 25 degrees.

BEARING REPLACEMENT

Put the bearing housing in a vice, use a pry bar to turn the bearing in the housing parallel with the slots, remove the old bearing, apply anti-seize lubricant to the interior of the bearing housing, insert the new bearing in the slots, & use a pry bar to move back to position. Wobble the bearing around to help work the lubricant into the outer race of the bearing.



STORAGE

When storing the corn head for the offseason, it is OK for the 5000 Stalk Devastators to hold some weight of the corn head whether stored on the ground or on a trailer. Removing compression springs may help extend the service life.

LOCKING UP THE 5000 SERIES STALK DEVASTATOR

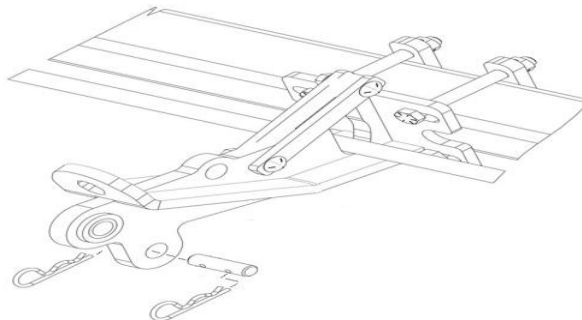

BOLT TORQUE

Mounting bolts and hardware

All hardware used on the 5000 Devastator is Grade 5 unless otherwise noted. Grade 5 cap screws are marked with three radial lines on the head. If hardware must be replaced, be sure to replace it with hardware of equal size, strength and thread type. Refer to the torque values chart when tightening hardware.



Important: Over tightening hardware can cause as much damage as when under tightening. Tightening hardware beyond the recommended range can reduce its shock load capacity.

The chart below is a guide for proper torque. Use it unless a specified torque is called out elsewhere in the manual.

Torque is the force you apply to the wrench handle or the cheater bar, times the length of the handle or bar.

Use a torque wrench whenever possible.

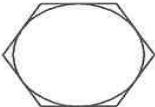
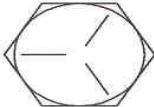
The following table shows torque in ft. lbs. for coarse thread hardware.

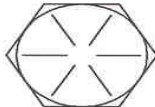
BOLT DIA. AND THREADS PER INCH		 OR 	
	GRADE 2	GRADE 5 A-325	GRADE 8
3/8-16	25	35	50
7/16-14	35	55	80
1/2-13	55	85	125
9/16-12	75	125	175
5/8-11	105	170	235
3/4-10	185	305	425
7/8-9	170	445	690
1-8	260	670	1030
1 1/8-7	365	900	1460
1 1/4-7	515	1275	2060
1 3/8-6	675	1675	2700
1 1/2-6	900	2150	3500
1 3/4-5	1410	3500	5600

INSTALLATION TOOLS REQUIRED:

- Pneumatic or electric impact driver
- 3/4 & 15/16 size sockets
- 10" impact driver extension
- Ratchet
- 3/4, 15/16, & 1 1/8 size wrenches
- 5/16 Allen Wrench
- Torque Wrench



5000-005B ASSEMBLY INSTRUCTIONS / PART ID

CASEIH 3206, 3406 NH98D 6 ROW

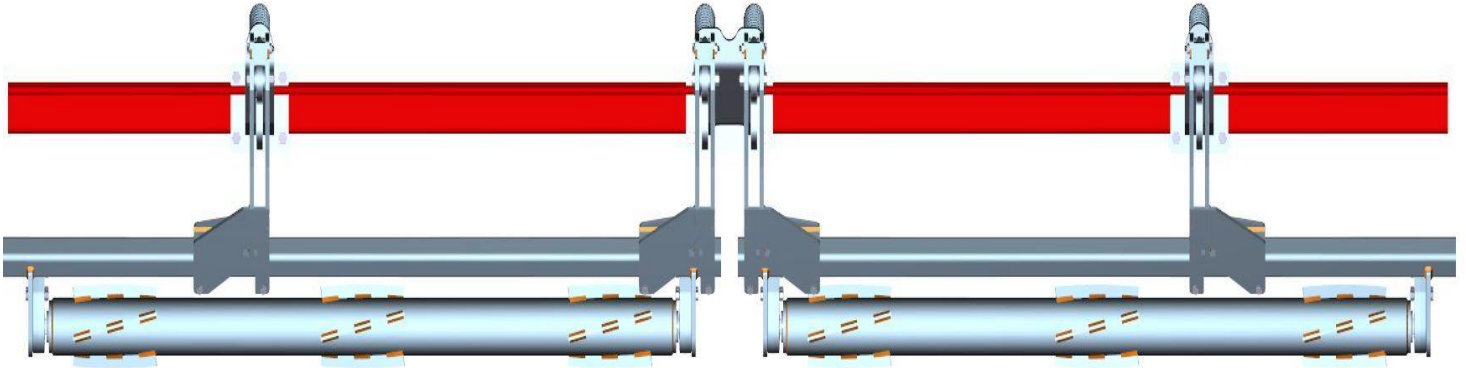

Step 1: Install 1) 5000-215 single mount to the frame between rows 1 & 2 and 5 & 6. Install 1) 5000-216 double mount between rows 3 & 4. Use 4) 5/8" X 6" bolts, 2) mount straps, & 4) 5/8" lock hex nuts to fasten the mounts to the corn head frame.

Step 2: Install the 5000-309 support straps to each mount using 1/2" X 2" carriage bolts & 1/2" flange whiz lock nuts. Install the 5000-323 lock up pin in the storage location & secure each in place with 2) 7 gauge cotter hairpin.

Step 3: Install 1) 5000-318 pivot bushing in each single mount and 2) pivot bushings in the double mount. Attach 1) 5000-259 RH over bearing arm to the single mount between rows 1 & 2 and 1) RH over bearing arm to the side of the double mount that is closer to row 3. Align the lower hole on each arm with the pivot bushing and insert a 5/8" X 3" bolt through & fasten with a 5/8" lock nut. Attach 1) 5000-256 LH over bearing arm to the single mount between rows 5 & 6 & 1) LH over bearing arm to the side of the double mount that is closer to row 4. Align the lower hole on each arm with the pivot bushing and insert a 5/8" X 3" bolt through & fasten with a 5/8" lock nut.

Step 4: Install 1) 2570-126 3/4" X 10" eyebolt to each single mount and 2) eyebolts to the double mount. Attach each over bearing arm to the eyebolt using 1) 2510-121 5/8" diameter shoulder bolt, 2) 2526-449 5/8" flat washers, & 1) 2520-364 1/2" jam lock nut. The 5/8" flat washers go on each side of the eyebolt & inside the arm channel. The shoulder bolt should be inserted through the top hole on each arm. Only tighten the 1/2" jam lock nut until it makes slight contact with the over bearing arm.

Step 5: Install the 2550-709 compression spring over the eyebolt, place the 2975-302 spring bushing over the eyebolt & onto the compression spring, & secure with the 2520-511 3/4" lock nut. Tighten the lock nut to be flush with the end of the eyebolt.

Step 6: Install each 3 row roller mount. For rows 1 – 3, slide the 5000-261 longer roller mount into place between the plates on the over bearing arm between rows 1 & 2. The bearing mount tab on the roller mount tube will be between the cut out opening on the arm closest to row 3. Use 2) 5000-378 spacer bushings, 2) 1/2" X 3 3/4" bolts, & 2) 1/2" lock nuts to attach the roller mount tube. Repeat this process to attach the 5000-254 roller mount for rows 4 – 6 using the over bearing arm between rows 5 & 6 & the arm closest to row 4. Do not tighten each roller mount into place until after the roller is installed so you can center the roller if needed. Make sure the bearing support is on the back side of the roller mount tab.

Step 7: Attach each roller to the roller mount using 2) 5000-322 shim washers, 2) 5000-355 bearing assemblies, 6) 1/2" X 2 1/2" bolts, & 6) 1/2" lock nuts per roller.

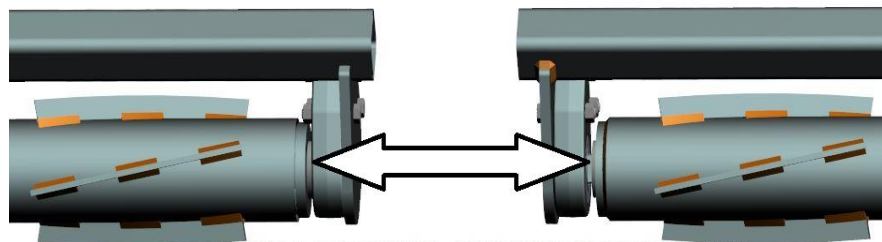

THE SIDE OF THE BEARING ASSEMBLY WHERE THE BEARING IS PROTRUDING MUST BE INSTALLED TOWARD THE ROLLER!

NOTE: BEARING HOUSING SHOULD BE LUBRICATED WITH POLYUREA GREASE BEFORE USE AND THEN EVERY 100 HOURS OF OPERATION



5000-005B ASSEMBLY INSTRUCTIONS / PART ID

CASEIH 3206, 3406 NH98D 6 ROW

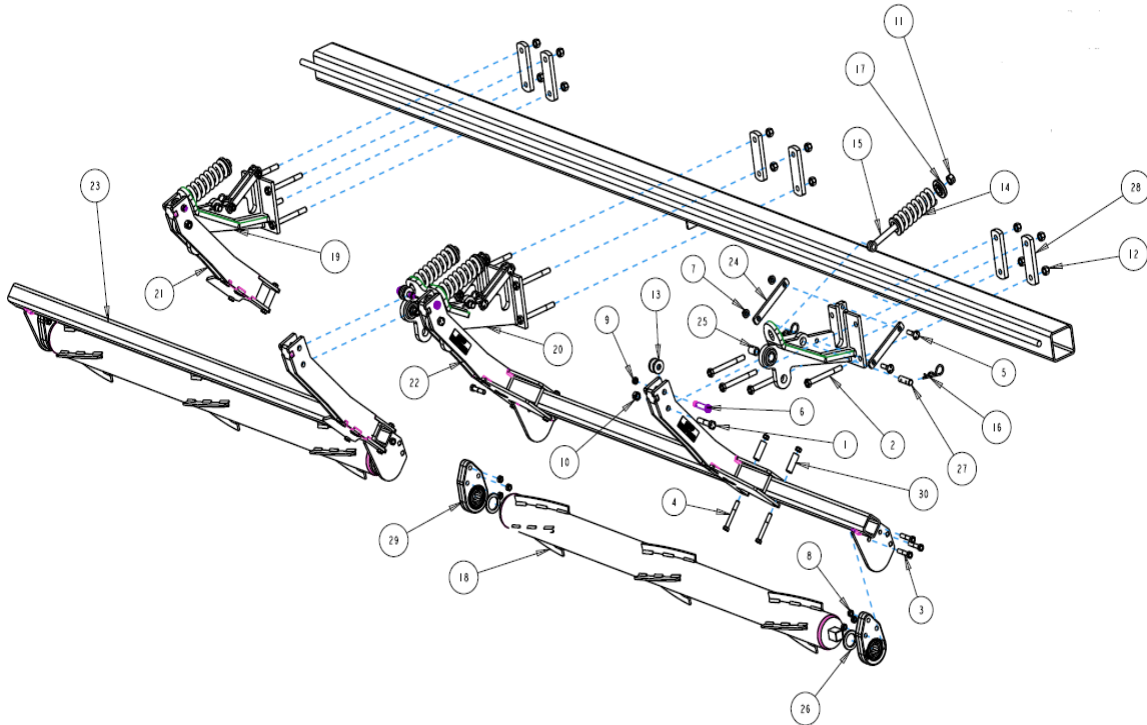

ITEM	PART #	DESCRIPTION	QTY
1	2502-325	5/8-11 X 3 CAP SCREW GRADE 5	4
2	2502-352	5/8-11 X 6 CAP SCREW GRADE 8	12
3	2502-353	1/2-13 X 2.5 CAP SCREW GRADE 8	12
4	2502-365	1/2-13 X 3.75 CAP SCREW GRADE 5	8
5	2505-345	1/2-13 X 2 CARRIAGE BOLT GRADE 5	8
6	2510-121	5/8 SHOULDER BOLT THREAD 1/2-13	4
7	2520-361	1/2-13 FLANGE HEX NUT GRADE 5	8
8	2520-362	1/2-13 LOCK HEX NUT GRADE 8	20
9	2520-364	1/2-13 HEX JAM NUT	4
10	2520-459	5/8-11 LOCK HEX NUT GRADE 5	4
11	2520-515	3/4-10 LOCK HEX NUT GRADE 2	4
12	2520-603	5/8-11 TOP LOCK HEX NUT GRADE 8	12
13	2526-449	5/8 FLAT WASHER 1/4" THICK	8
14	2550-709	1/2" WIRE 2.5" OD X 1.5" ID X 7.25" LONG COMPRESSION SPRING	4
15	2570-126	3/4 X 10 EYE BOLT	4
16	2570-465	HAIRPIN	8
17	2975-302	SPRING BUSHING	4
18	5000-211B	ROLLER 76"	2
19	5000-215	SINGLE MOUNT BRACKET	2
	2528-369	SLEEVE	1/MOUNT
20	5000-216	DOUBLE MOUNT BRACKET	1
	2528-369	SLEEVE	2/MOUNT
21	5000-256	LEFT HAND ARM 19"	2
22	5000-259	RIGHT HAND ARM 19"	2
23	5000-261	ROLLER MOUNT 3 ROW LONG	2
24	5000-309	SUPPORT STRAP	8
25	5000-318	PIVOT BUSHING	4
26	5000-322	SHIM WASHER	4
27	5000-323	LOCK UP PIN	4
28	5000-331	MOUNT STRAP	6
29	5000-355	BEARING ASSEMBLY	4
	2550-059	BEARING	4
30	5000-378	SPACER BUSHING	8

5000-006C ASSEMBLY INSTRUCTIONS / PART ID

CASEIH 3208, 3408 NH98D 8 ROW

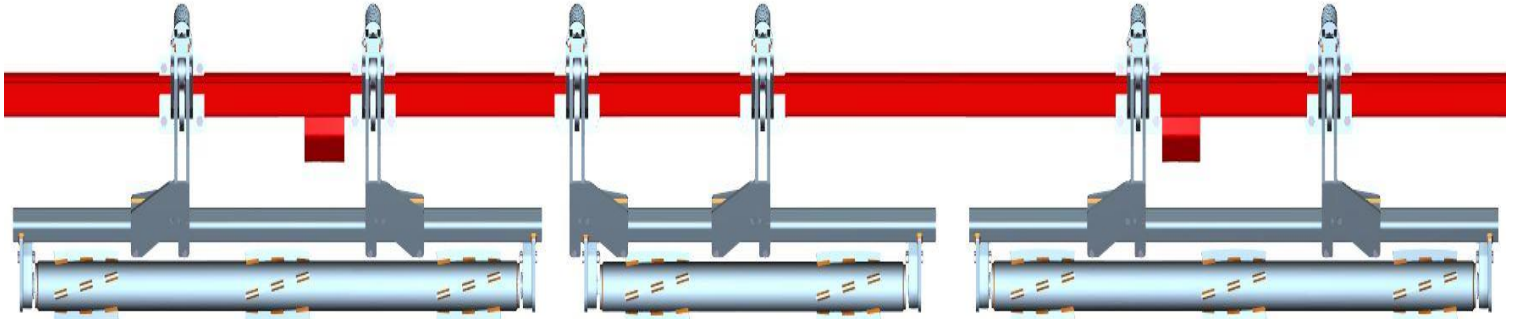

Step 1: Install 1) 5000-215 single mount to the frame between rows 1 & 2, 2 & 3, 4 & 5, 5 & 6, 6 & 7, and 7 & 8. Use 4) 5/8" X 6" bolts, 2) mount straps, & 4) 5/8" lock hex nuts to fasten the mounts to the corn head frame.

Step 2: Install the 5000-309 support straps to each mount using 1/2" X 2" carriage bolts & 1/2" flange whiz lock nuts. Install the 5000-323 lock up pin in the storage location & secure each in place with 2) 7 gauge cotter hairpin.

Step 3: Install 1) 5000-318 pivot bushing in each single mount. Attach 1) 5000-259 RH over bearing arm to the single mount between rows 1 & 2, 5 & 6, and 6 & 7. Align the lower hole on each arm with the pivot bushing and insert a 5/8" X 3" bolt through & fasten with a 5/8" lock nut. Attach 1) 5000-256 LH over bearing arm to the single mount between rows 2 & 3, 4 & 5, & 7 & 8. Align the lower hole on each arm with the pivot bushing & insert a 5/8" X 3" bolt through & fasten with a 5/8" lock nut.

Step 4: Install 1) 2570-126 3/4" X 10" eyebolt to each single mount. Attach each over bearing arm to the eyebolt using 1) 2510-121 5/8" diameter shoulder bolt, 2) 2526-449 5/8" flat washers, & 1) 2520-364 1/2" jam lock nut. The 5/8" flat washers go on each side of the eyebolt & inside the arm channel. The shoulder bolt should be inserted through the top hole on each arm. Only tighten the 1/2" jam lock nut until it makes slight contact with the over bearing arm.

Step 5: Install the 2550-709 compression spring over each eyebolt, place the 2975-302 spring bushing over the eyebolt & onto the compression spring, & secure with the 2520-511 3/4" lock nut. Tighten the lock nut to be flush with the end of the eyebolt.

Step 6: Install each 3 row roller mount. For rows 1 – 3, slide the roller mount into place between the plates on the over bearing arm between rows 1 & 2 and 2 & 3. For rows 6 – 8, slide the roller mount into place between the plates on the over bearing arms between rows 6 & 7 and 7 & 8. Use 2) 5000-378 spacer bushings, 2) 1/2" X 3 3/4" bolts, & 2) 1/2" lock nuts to attach the roller mount tube. Install the 2 row roller mount to the arms between rows 4 & 5 and 5 & 6. The bearing mount tab on the roller mount tube will be between the cut out opening on the arm between rows 5 & 6. Do not tighten each roller mount into place until after the roller is installed so you can center the roller if needed. Make sure the bearing support is on the back side of the roller mount tab.

Step 7: Attach each roller to the roller mount using 2) 5000-322 shim washers, 2) 5000-355 bearing assemblies, 6) 1/2" X 2 1/2" bolts, & 6) 1/2" lock nuts per roller.

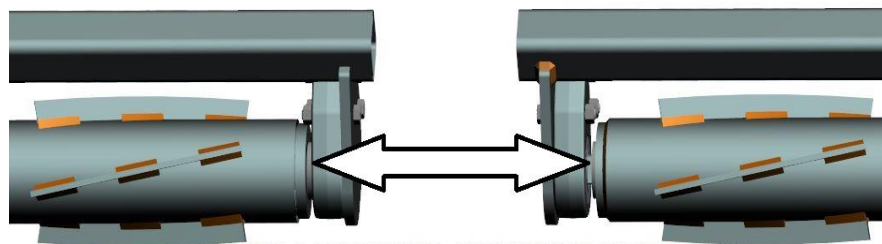

THE SIDE OF THE BEARING ASSEMBLY WHERE THE BEARING IS PROTRUDING MUST BE INSTALLED TOWARD THE ROLLER!

NOTE: BEARING HOUSING SHOULD BE LUBRICATED WITH POLYUREA GREASE BEFORE USE AND THEN EVERY 100 HOURS OF OPERATION



5000-006C ASSEMBLY INSTRUCTIONS / PART ID

CASEIH 3208, 3408 NH98D 8 ROW

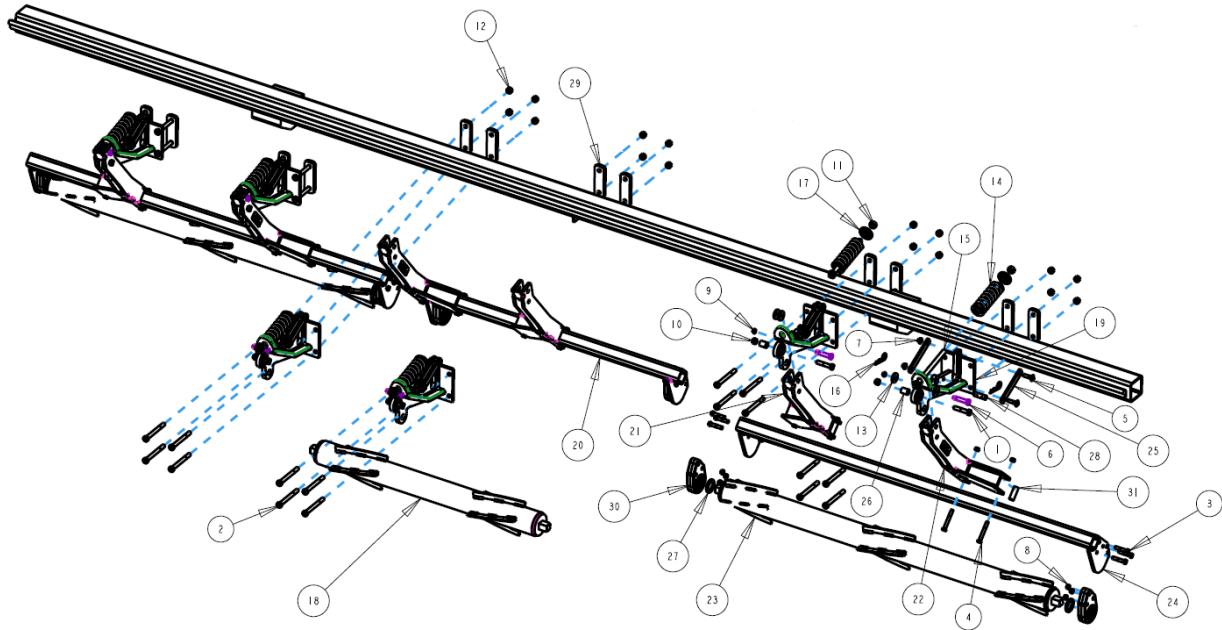

ITEM	PART #	DESCRIPTION	QTY
1	2502-325	5/8-11 X 3 CAP SCREW GRADE 5	6
2	2502-352	5/8-11 X 6 CAP SCREW GRADE 8	24
3	2502-353	1/2-13 X 2.5 CAP SCREW GRADE 8	18
4	2502-365	1/2-13 X 3.75 CAP SCREW GRADE 5	12
5	2505-345	1/2-13 X 2 CARRIAGE BOLT GRADE 5	12
6	2510-121	5/8 SHOULDER BOLT THREAD 1/2-13	6
7	2520-361	1/2-13 FLANGE HEX NUT GRADE 5	12
8	2520-362	1/2-13 LOCK HEX NUT GRADE 8	30
9	2520-364	1/2-13 HEX JAM NUT	6
10	2520-459	5/8-11 LOCK HEX NUT GRADE 5	6
11	2520-511	3/4-16 LOCK HEX NUT	6
12	2520-603	5/8-11 TOP LOCK HEX NUT GRADE 8	24
13	2526-449	5/8 FLAT WASHER 1/4" THICK	12
14	2550-709	1/2" WIRE 2.5" OD X 1.5" ID X 7.25" LONG COMPRESSION SPRING	6
15	2570-126	3/4 X 10 EYE BOLT	6
16	2570-465	HAIRPIN	12
17	2975-302	SPRING BUSHING	6
18	5000-203B	ROLLER 48"	1
19	5000-215	SINGLE MOUNT BRACKET	6
	2528-369	SLEEVE	1/MOUNT
20	5000-255	ROLLER MOUNT 2 ROW	1
21	5000-256	LEFT HAND ARM 19"	3
22	5000-259	RIGHT HAND ARM 19"	3
23	5000-272	ROLLER 3 ROW 30	2
24	5000-275A	ROLLER MOUNT 3 ROW	2
25	5000-309	SUPPORT STRAP	12
26	5000-318	PIVOT BUSHING	6
27	5000-322	SHIM WASHER	6
28	5000-323	LOCK UP PIN	6
29	5000-331	MOUNT STRAP	12
30	5000-355	BEARING ASSEMBLY	6
	2550-059	BEARING	6
31	5000-378	SPACER BUSHING	12

5000-007D ASSEMBLY INSTRUCTIONS / PART ID

DRAGO 630

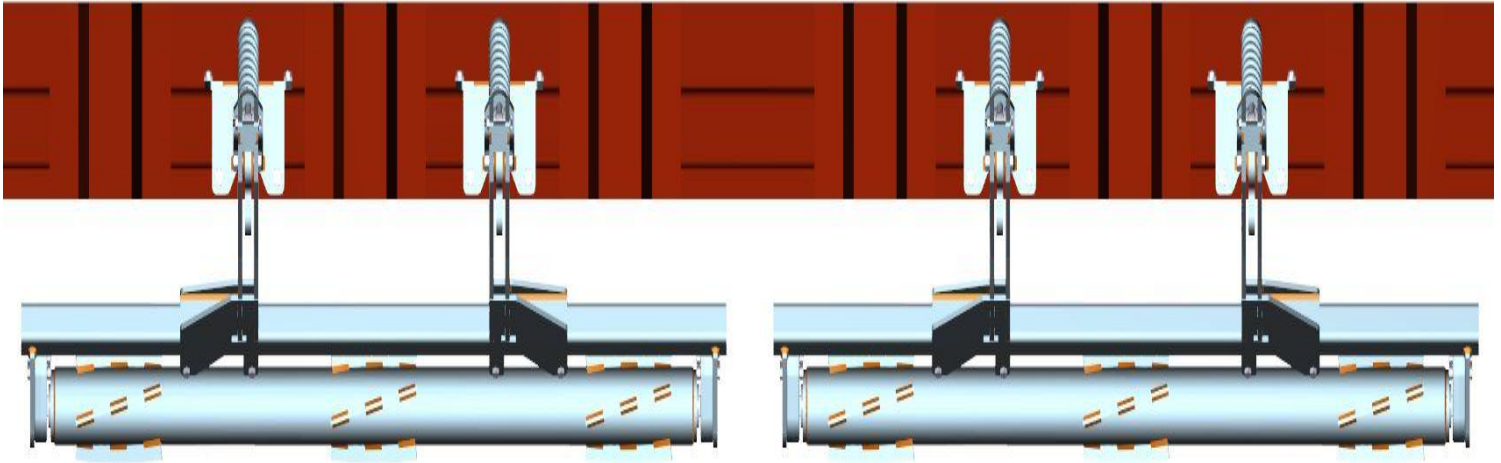

Step 1: Attach the 5000-218 Drago mount brackets to the frame using 2) 5/8" X 3" bolts & 2) 5000-340 clamp blocks for the bottom set of holes & 2) 1/2" X 2 bolts, 2) 5000-339 mount plate washers, & 2) 1/2" hex flange lock nuts for the top set of holes. Mounting brackets should be located between rows 1 & 2, 2 & 3, 4 & 5, & 5 & 6. Install the 5000-323 lock up pin in the storage location & secure each in place with 2) 7 gauge cotter hairpin.

Step 2: Install 1) 5000-318 pivot bushing in each mount. Attach 1) 5000-259 RH over bearing arm to each mount between rows 1 & 2 and 4 & 5. Align the lower hole on each arm with the pivot bushing & insert a 5/8" X 3" bolt through & fasten with a 5/8" lock nut. Attach 1) 5000-256 LH over bearing arm to each mount between rows 2 & 3 and 5 & 6 using 5/8" X 3 bolt & 5/8" nut.

Step 3: Install 1) 2570-126 3/4" X 10" eyebolt to each mount. Attach each over bearing arm to the eyebolt using 1) 2510-121 5/8" diameter shoulder bolt, 2) 2526-449 5/8" flat washers, & 1) 2520-364 1/2" jam lock nut. The 5/8" flat washers go on each side of the eyebolt & inside the arm channel. The shoulder bolt should be inserted through the top hole on each arm. Only tighten the 1/2" jam lock nut until it makes slight contact with the over bearing arm.

Step 4: Install the 2550-709 compression spring over each eyebolt, place the 2975-302 spring bushing over the eyebolt & onto the compression spring, & secure with the 2520-511 3/4" lock nut. Tighten the lock nut to be flush with the end of the eyebolt.

Step 5: Install each 3 row roller mount. For rows 1 – 3, slide the roller mount into place between the plates on the over bearing arm between rows 1 & 2 and 2 & 3. Use 2) 5000-378 spacer bushings, 2) 1/2" X 3 3/4" bolts, & 2) 1/2" lock nuts to attach the roller mount tube to each arm clamp. Repeat this process to attach the roller mount for rows 4 – 6 using the over bearing arm between rows 4 & 5 and 5 & 6. Do not tighten each roller mount into place until after the roller is installed so you can center the roller if needed. Make sure the bearing support is on the back side of the roller mount tab.

Step 6: Attach each roller to the roller mount using 2) 5000-322 shim washers, 2) 5000-355 bearing assemblies, 6) 1/2" X 2 1/2" bolts, & 6) 1/2" lock nuts per roller.

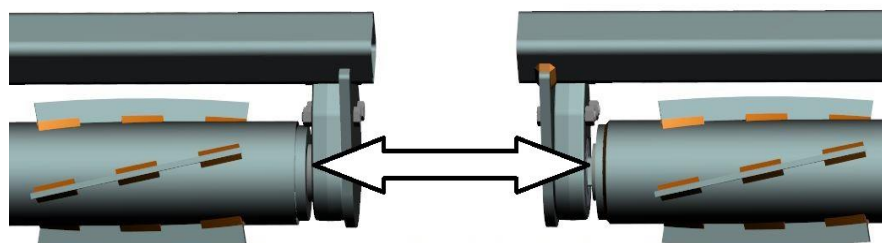

THE SIDE OF THE BEARING ASSEMBLY WHERE THE BEARING IS PROTRUDING MUST BE INSTALLED TOWARD THE ROLLER!

NOTE: BEARING HOUSING SHOULD BE LUBRICATED WITH POLYUREA GREASE BEFORE USE AND THEN EVERY 100 HOURS OF OPERATION



5000-007D ASSEMBLY INSTRUCTIONS / PART ID

DRAGO 630

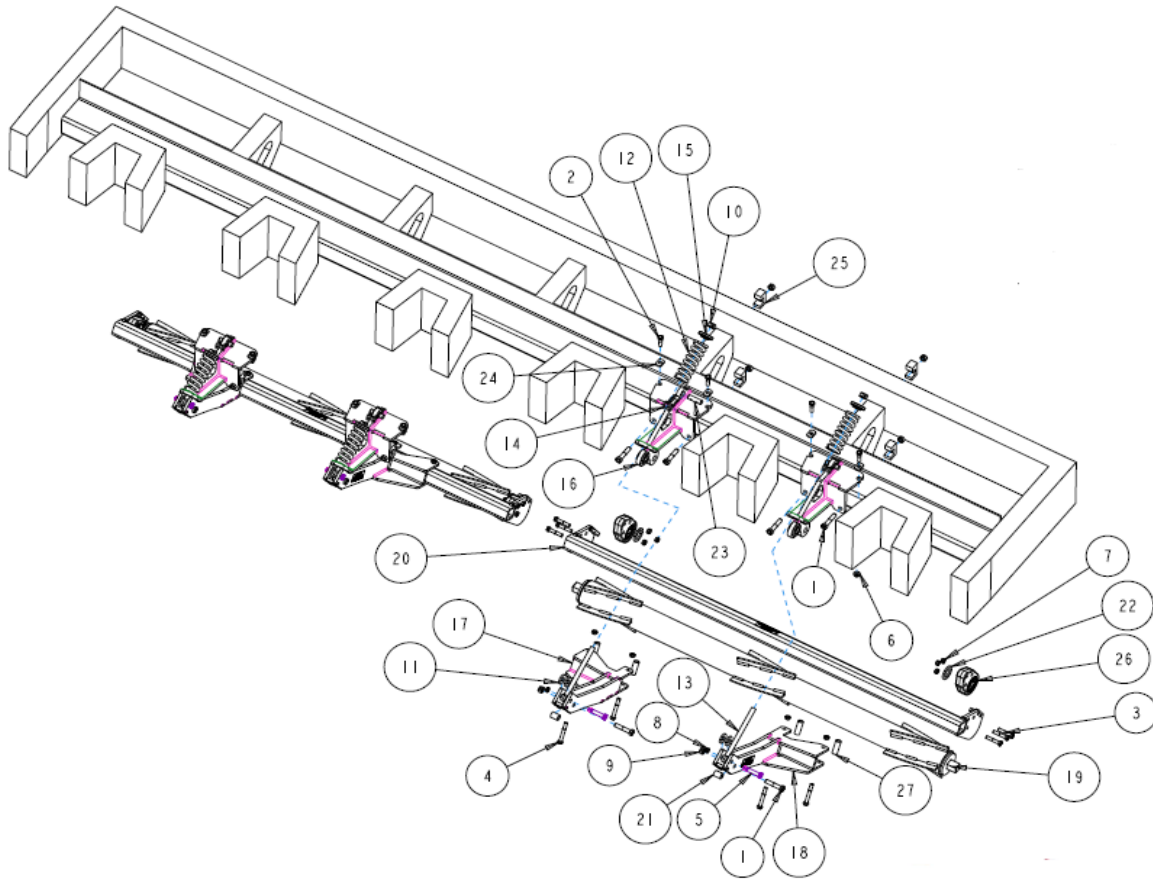

ITEM	PART #	DESCRIPTION	QTY
1	2502-325	5/8-11 X 3 CAP SCREW GRADE 5	12
2	2502-351	1/2-13 X 2 CAP SCREW GRADE 5	8
3	2502-353	1/2-13 X 2.5 CAP SCREW GRADE 8	12
4	2502-365	1/2-13 X 3.75 CAP SCREW GRADE 5	8
5	2510-121	5/8 SHOULDER BOLT THREAD 1/2-13	4
6	2520-361	1/2-13 FLANGE HEX NUT GRADE 5	8
7	2520-362	1/2-13 LOCK HEX NUT GRADE 8	20
8	2520-364	1/2-13 HEX JAM NUT	4
9	2520-459	5/8-11 LOCK HEX NUT GRADE 5	12
10	2520-515	3/4-10 LOCK HEX NUT GRADE 2	4
11	2526-449	5/8 FLAT WASHER 1/4" THICK	8
12	2550-709	1/2" WIRE 2.5" OD X 1.5" ID X 7.25" LONG COMPRESSION SPRING	4
13	2570-126	3/4 X 10 EYE BOLT	4
14	2570-465	HAIRPIN	8
15	2975-302	SPRING BUSHING	4
16	5000-218B	MOUNT BRACKET DRAGO	4
	2528-369	SLEEVE	1/MOUNT
17	5000-256	LEFT HAND ARM 19"	2
18	5000-259	RIGHT HAND ARM 19"	2
19	5000-272	ROLLER 3 ROW 30	2
20	5000-275A	ROLLER MOUNT 3 ROW	2
21	5000-318	PIVOT BUSHING	4
22	5000-322	SHIM WASHER	4
23	5000-323	LOCK UP PIN	4
24	5000-339	CLIPPED WASHER	8
25	5000-340	CLAMP BLOCK	8
26	5000-355	BEARING ASSEMBLY	4
	2550-059	BEARING	4
27	5000-378	SPACER BUSHING	8

5000-009C ASSEMBLY INSTRUCTIONS / PART ID

CASEIH 2206, 2406 NH98C/996 6 ROW

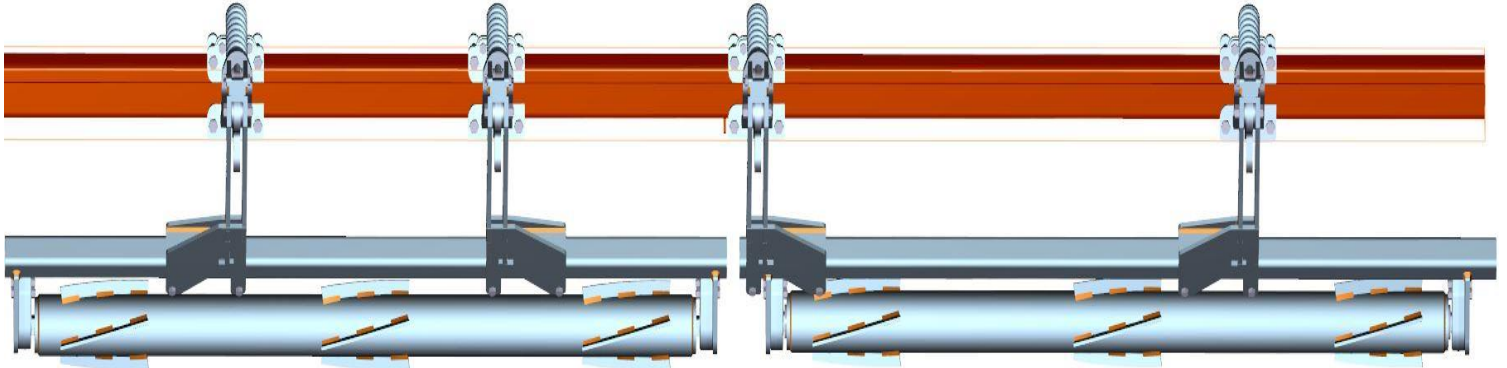

Step 1: Install each 5000-224 single mount to the corn head frame using 4) 5/8" X 6" bolts, 2) 5000-341 mount straps, & 4) 5/8" lock nuts per mount. Mounting bracket locations will be between rows 1 & 2, 3 & 4, 4 & 5, & 5 & 6. Install the 5000-323 lock up pin in the storage location & secure each in place with 2) 7 gauge cotter hairpin.

Step 2: Install 1) 5000-223 support strap on each mount. Use 2) 1/2" – 13 X 1 1/2" bolts & 2) 1/2" – 13 flange whiz lock nuts to attach the support strap to the top set of holes on the mount plate & use 1) 1/2" – 13 X 2 1/4" bolt & 1) 1/2" – 13 flange whiz lock nut to attach the support strap to the main pivot plate.

Step 3: Install 1) 5000-318 pivot bushing in each mount. Attach 1) 5000-259 RH over bearing arm to each mount between rows 3 & 4 and 4 & 5. Attach 1) 5000-256 LH over bearing arm to each mount between rows 1 & 2 and 5 & 6. Align the lower hole on each arm with the pivot bushing and insert a 5/8" X 3" bolt through & fasten with a 5/8" lock nut.

Step 4: Install 1) 2570-126 3/4" X 10" eyebolt to each mount. Attach each over bearing arm to the eyebolt using 1) 2510-121 5/8" diameter shoulder bolt, 2) 2526-449 5/8" flat washers, & 1) 2520-364 1/2" jam lock nut. The 5/8" flat washers go on each side of the eyebolt & inside the arm channel. The shoulder bolt should be inserted through the top hole on each arm. Only tighten the 1/2" jam lock nut until it makes slight contact with the over bearing arm.

Step 5: Install the 2550-709 compression spring over each eyebolt, place the 2975-302 spring bushing over the eyebolt & onto the compression spring, & secure with the 2520-511 3/4" lock nut. Tighten the lock nut to be flush with the end of the eyebolt.

Step 6: Install each 3 row roller mount. For rows 1 – 3, slide the 5000-261 longer roller mount into place between the plates on the over bearing arm between rows 1 & 2 and 3 & 4. The bearing mount tab on the roller mount will be directly under the cut out on the over bearing arm clamps between rows 3 & 4. Use 2) 5000-378 spacer bushings, 2) 1/2" X 3 3/4" bolts, & 2) 1/2" lock nuts to attach the roller mount tube to each arm clamp. Repeat this process to attach the 5000-254 roller mount for rows 4 – 6 using the over bearing arm between rows 4 & 5 and 5 & 6. Do not tighten each roller mount into place until after the roller is installed so you can center the roller if needed. Make sure the bearing support is on the back side of the roller mount tab.

Step 7: Attach each roller to the roller mount using 2) 5000-322 shim washers, 2) 5000-355 bearing assemblies, 6) 1/2" X 2 1/2" bolts, & 6) 1/2" lock nuts per roller.

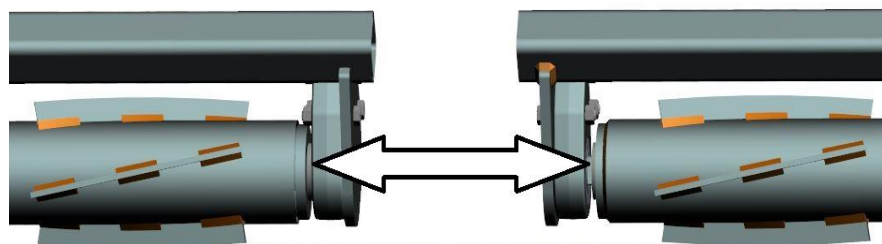

THE SIDE OF THE BEARING ASSEMBLY WHERE THE BEARING IS PROTRUDING MUST BE INSTALLED TOWARD THE ROLLER!

NOTE: BEARING HOUSING SHOULD BE LUBRICATED WITH POLYUREA GREASE BEFORE USE AND THEN EVERY 100 HOURS OF OPERATION



5000-009C ASSEMBLY INSTRUCTIONS / PART ID

CASEIH 2206, 2406 NH98C/996 6 ROW

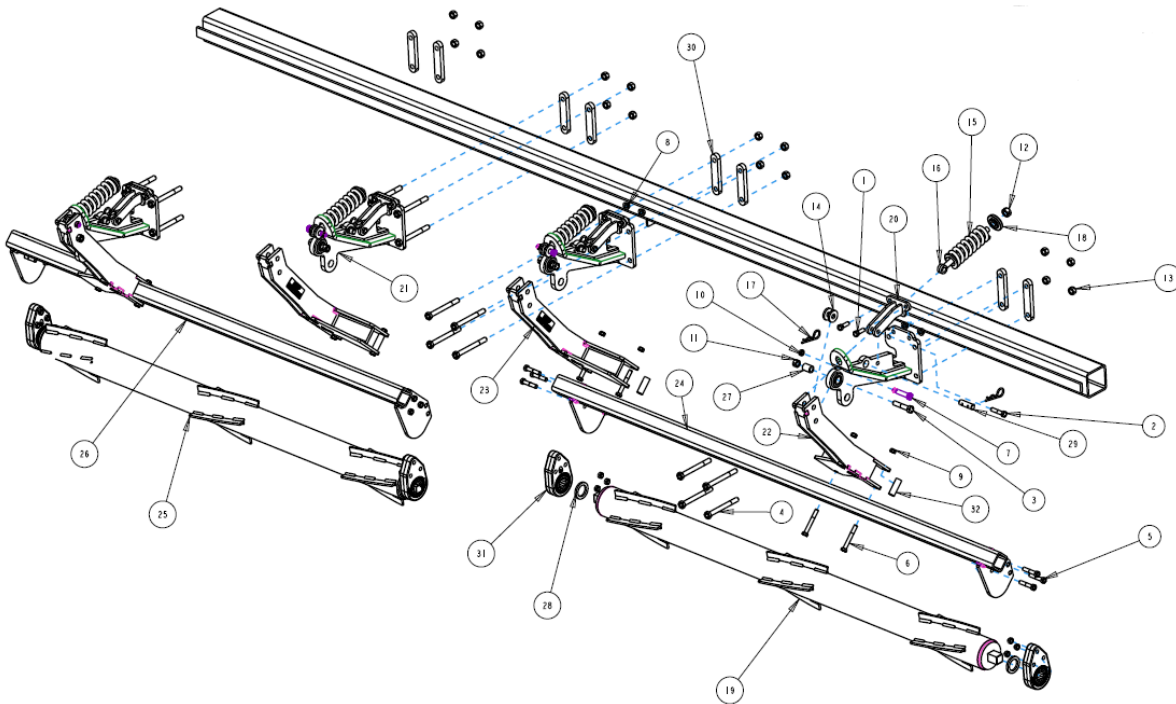

ITEM	PART #	DESCRIPTION	QTY
1	2502-294	1/2-13 X 1.5 CAP SCREW GRADE 5	8
2	2502-314	1/2-13 X 2.25 CAP SCREW GRADE 5	4
3	2502-325	5/8-11 X 3 CAP SCREW GRADE 5	4
4	2502-352	5/8-11 X 6 CAP SCREW GRADE 8	16
5	2502-353	1/2-13 X 2.5 CAP SCREW GRADE 8	12
6	2502-365	1/2-13 X 3.75 CAP SCREW GRADE 5	8
7	2510-121	5/8" DIAMETER SHOULDER, 2 1/4" LONG SHOULDER, 1/2" - 13	4
8	2520-361	1/2-13 FLANGE WHIZ LOCK HEX NUT GRADE 5	12
9	2520-362	1/2-13 HEX LOCK NUT GRADE 8	20
10	2520-364	1/2-13 HEX JAM LOCK NUT	4
11	2520-459	5/8-11 LOCK HEX NUT GRADE 5	4
12	2520-515	3/4-10 LOCK HEX NUT GRADE 2	4
13	2520-603	5/8-11 TOP LOCK HEX NUT GRADE 8	16
14	2526-449	5/8" FLAT WASHER 1/4" THICK	8
15	2550-709	1/2" WIRE 2.50D X 1.5ID X 7.25 LONG COMPRESSION SPRING	4
16	2570-126	3/4 X 10 EYEBOLT	4
17	2570-465	HAIRPIN COTTER	8
18	2975-302	SPRING BUSHING	4
19	5000-211B	ROLLER 76"	1
20	5000-223	SUPPORT STRAP	4
21	5000-224	MOUNT BRACKET	4
	2528-369	SLEEVE	1/MOUNT
22	5000-256	LEFT HAND ARM 19"	2
23	5000-259	RIGHT HAND ARM 19"	2
24	5000-261	ROLLER MOUNT, LONG	1
25	5000-272	ROLLER 71.5"	1
26	5000-275A	ROLLER MOUNT SHORT	1
27	5000-318	PIVOT BUSHING	4
28	5000-322	SHIM WASHER	4
29	5000-323	LOCK UP PIN	4
30	5000-341	MOUNT STRAP	8
31	5000-355	BEARING ASSEMBLY	4
	2550-059	BEARING	4
32	5000-378	SPACER BUSHING	8

5000-010C ASSEMBLY INSTRUCTIONS / PART ID

CASEIH 2208, 2408 NH96C, 98C, 996 8 ROW

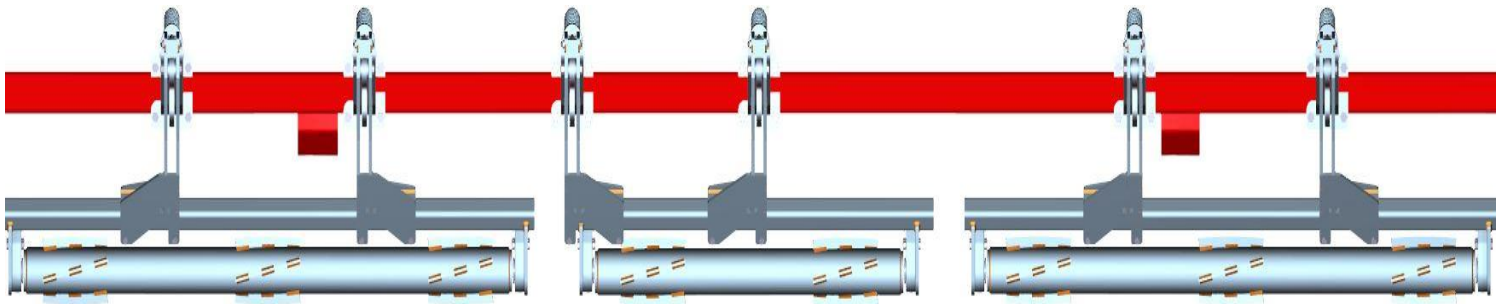

- Step 1:** Install each 5000-224 single mount to the corn head frame using 4) 5/8" X 6" bolts, 2) 5000-341 mount straps, & 4) 5/8" lock nuts per mount. Mounting bracket locations will be between rows 1 & 2, 2 & 3, 4 & 5, 5 & 6, 6 & 7, & 7 & 8.
- Step 2:** Install 1) 5000-223 support strap on each mount. Use 2) 1/2" – 13 X 1 1/2" bolts & 2) 1/2" – 13 flange whiz lock nuts to attach the support strap to the top set of holes on the mount plate & use 1) 1/2" – 13 X 2 1/4" bolt & 1) 1/2" – 13 flange whiz lock nut to attach the support strap to the main pivot plate. Install the 5000-323 lock up pin in the storage location & secure each in place with 2) 7 gauge cotter hairpin.
- Step 3:** Install 1) 5000-318 pivot bushing in each mount. Attach 1) 5000-259 RH over bearing arm to each mount between rows 1 & 2, 5 & 6, & 6 & 7. Attach 1) 5000-256 LH over bearing arm to each mount between rows 2 & 3, 4 & 5, & 7 & 8. Align the lower hole on each arm with the pivot bushing and insert a 5/8" X 3" bolt through & fasten with a 5/8" lock nut.
- Step 4:** Install 1) 2570-126 3/4" X 10" eyebolt to each mount. Attach each over bearing arm to the eyebolt using 1) 2510-121 5/8" diameter shoulder bolt, 2) 2526-449 5/8" flat washers, & 1) 2520-364 1/2" jam lock nut. The 5/8" flat washers go on each side of the eyebolt & inside the arm channel. The shoulder bolt should be inserted through the top hole on each arm. Only tighten the 1/2" jam lock nut until it makes slight contact with the over bearing arm.
- Step 5:** Install the 2550-709 compression spring over each eyebolt, place the 2975-302 spring bushing over the eyebolt & onto the compression spring, & secure with the 2520-511 3/4" lock nut. Tighten the lock nut to be flush with the end of the eyebolt.
- Step 6:** Install each 3 row roller mount. For rows 1 – 3, slide the roller mount into place between the plates on the over bearing arm between rows 1 & 2 and 2 & 3. Use 2) 5000-378 spacer bushings, 2) 1/2" X 3 3/4" bolts, & 2) 1/2" lock nuts to attach the roller mount tube to each arm clamp. Repeat this process to attach the roller mount for rows 6 – 8 using the over bearing arm between rows 6 & 7 and 7 & 8. . Install the 2 row roller mount to the arms between rows 4 & 5 and 5 & 6. The bearing mount tab on the roller mount tube will be between the cut out opening on the arm between rows 5 & 6. Do not tighten each roller mount into place until after the roller is installed so you can center the roller if needed. Make sure the bearing support is on the back side of the roller mount tab.
- Step 7:** Attach each roller to the roller mount using 2) 5000-322 shim washers, 2) 5000-355 bearing assemblies, 6) 1/2" X 2 1/2" bolts, & 6) 1/2" lock nuts per roller.

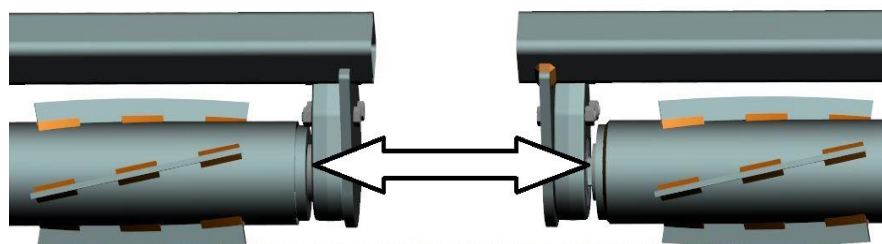

THE SIDE OF THE BEARING ASSEMBLY WHERE THE BEARING IS PROTRUDING MUST BE INSTALLED TOWARD THE ROLLER!

NOTE: BEARING HOUSING SHOULD BE LUBRICATED WITH POLYUREA GREASE BEFORE USE AND THEN EVERY 100 HOURS OF OPERATION



5000-010C ASSEMBLY INSTRUCTIONS / PART ID

CASEIH 2208, 2408 NH96C, 98C, 996 8 ROW

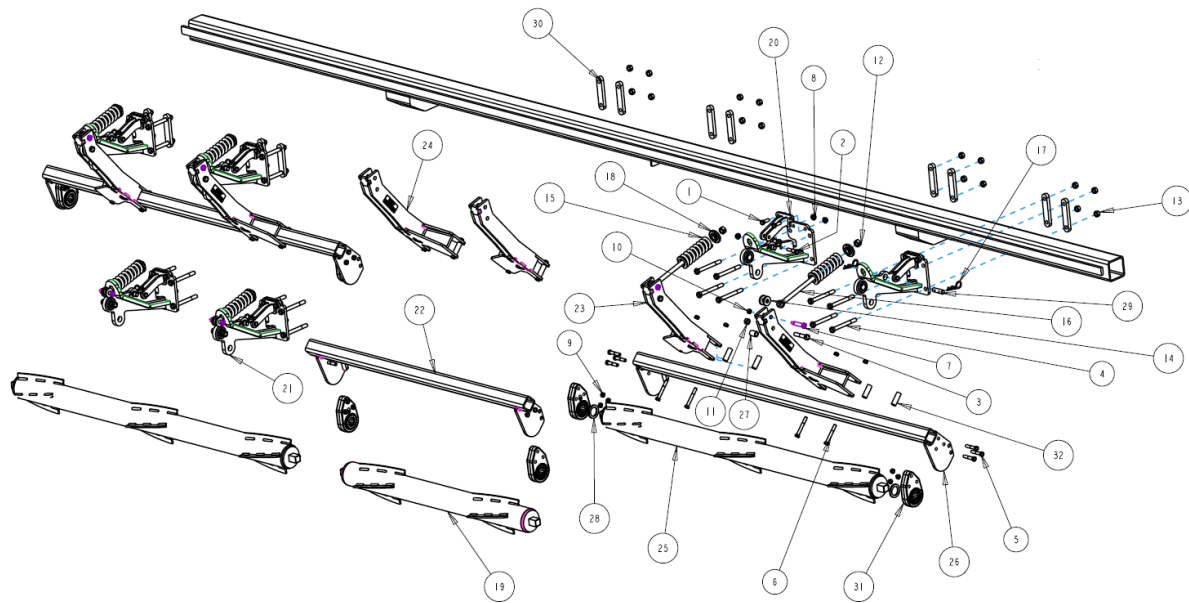

ITEM	PART #	DESCRIPTION	QTY
1	2502-294	1/2-13 X 1.5 CAP SCREW GRADE 5	12
2	2502-314	1/2-13 X 2.25 CAP SCREW GRADE 5	6
3	2502-325	5/8-11 X 3 CAP SCREW GRADE 5	6
4	2502-352	5/8-11 X 6 CAP SCREW GRADE 8	24
5	2502-353	1/2-13 X 2.5 CAP SCREW GRADE 8	18
6	2502-365	1/2-13 X 3.75 CAP SCREW GRADE 5	12
7	2510-121	5/8" DIAMETER SHOULDER, 2 1/4" LONG SHOULDER, 1/2" - 13	6
8	2520-361	1/2-13 FLANGE WHIZ LOCK HEX NUT GRADE 5	18
9	2520-362	1/2-13 HEX LOCK NUT GRADE 8	30
10	2520-364	1/2-13 HEX JAM LOCK NUT	6
11	2520-459	5/8-11 LOCK HEX NUT GRADE 5	6
12	2520-515	3/4-10 LOCK HEX NUT GRADE 2	6
13	2520-603	5/8-11 TOP LOCK HEX NUT GRADE 8	24
14	2526-449	5/8" FLAT WASHER 1/4" THICK	12
15	2550-709	1/2" WIRE 2.5OD X 1.5ID X 7.25 LONG COMPRESSION SPRING	6
16	2570-126	3/4 X 10 EYEBOLT	6
17	2570-465	HAIRPIN COTTER	12
18	2975-302	SPRING BUSHING	6
19	5000-203B	ROLLER 48"	1
20	5000-223	SUPPORT STRAP	6
21	5000-224	MOUNT BRACKET	6
	2528-369	SLEEVE	1/MOUNT
22	5000-255	ROLLER MOUNT 2 ROW	1
23	5000-256	LEFT HAND ARM 19"	3
24	5000-259	RIGHT HAND ARM 19"	3
25	5000-272	ROLLER 71.5"	2
26	5000-275A	ROLLER MOUNT SHORT	2
27	5000-318	PIVOT BUSHING	6
28	5000-322	SHIM WASHER	6
29	5000-323	LOCK UP PIN	6
30	5000-341	MOUNT STRAP	12
31	5000-355	BEARING ASSEMBLY	6
	2550-059	BEARING	6
32	5000-378	SPACER BUSHING	12

5000-013B ASSEMBLY INSTRUCTIONS / PART ID

CASEIH 1063 6 ROW

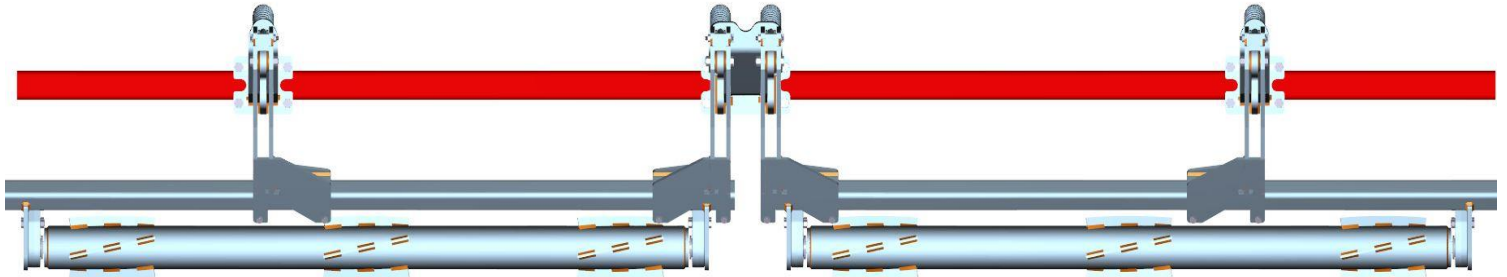

Step 1: Install each 5000-202 single mount & 5000-201 double mount to the corn head frame, using 4) 5/8" X 6" bolts, 2) 5000-319 mount straps, & 4) 5/8" lock nuts per mount. Single mount locations will be between rows 1 & 2 and 5 & 6. The double mount will be located between rows 3 & 4

Step 2: Install 2) 5000-309 support straps on each single mount & 4) 5000-309 support straps on the double mount. Use 2) 1/2" – 13 X 2" carriage bolts & 2) 1/2" – 13 flange whiz lock nuts to attach the support straps to each single mount & use 4) 1/2" – 13 x 2" carriage bolts & 4) 1/2" – 13 flange whiz lock nuts to attach the support straps to the double mount. Install the 5000-323 lock up pin in the storage location & secure each in place with 2) 7 gauge cotter hairpin.

Step 3: Install 1) 5000-318 pivot bushing in each single mount & 2) 5000-318 pivot bushings in the double mount. Attach 1) 5000-256 LH over bearing arm to the single mount between rows 1 & 2. Install 1) 5000-259 RH over bearing arm on the double mount to the side that is closest to row 3. Install 1) 5000-256 LH over bearing arm to the double mount to the side that is closest to row 4. Install 1) 5000-259 RH over bearing arm to the single mount between rows 5 & 6. Align the lower hole on each arm with the pivot bushing and insert a 5/8" X 3" bolt through & fasten with a 5/8" lock nut.

Step 4: Install 1) 2570-126 3/4" X 10" eyebolt to each single mount & 2) 2570-126 3/4" X 10" eyebolt to the double mount. Attach each over bearing arm to each eyebolt using 1) 2510-121 5/8" diameter shoulder bolt, 2) 2526-449 5/8" flat washers, & 1) 2520-364 1/2" jam lock nut. The 5/8" flat washers go on each side of the eyebolt & inside the arm channel. The shoulder bolt should be inserted through the top hole on each arm. Only tighten the 1/2" jam lock nut until it makes slight contact with the over bearing arm.

Step 5: Install the 2550-709 compression spring over each eyebolt, place the 2975-302 spring bushing over the eyebolt & onto the compression spring, & secure with the 2520-511 3/4" lock nut. Tighten the lock nut to be flush with the end of the eyebolt.

Step 6: Install each 5000-261 long 3 row roller mount. For rows 1 – 3, slide the roller mount into place between the plates on the over bearing arm between rows 1 & 2 and the arm between 3 & 4 that is closer to row 3. Use 2) 5000-378 spacer bushings, 2) 1/2" X 3 3/4" bolts, & 2) 1/2" lock nuts to attach the roller mount tube to each arm clamp. Repeat this process to attach the roller mount for rows 4 – 6 using the over bearing arm between rows 3 & 4 (arm that is closer to row 4) and 5 & 6. Do not tighten each roller mount into place until after the roller is installed so you can center the roller if needed. Make sure the bearing support is on the back side of the roller mount tab.

Step 7: Attach each roller to the 3 row roller mount using 2) 5000-322 shim washers, 2) 5000-355 bearing assemblies, 6) 1/2" X 2 1/2" bolts, & 6) 1/2" lock nuts per roller.

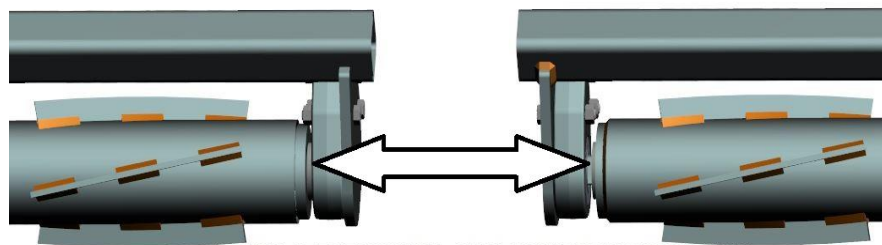

THE SIDE OF THE BEARING ASSEMBLY WHERE THE BEARING IS PROTRUDING MUST BE INSTALLED TOWARD THE ROLLER!

NOTE: BEARING HOUSING SHOULD BE LUBRICATED WITH POLYUREA GREASE BEFORE USE AND THEN EVERY 100 HOURS OF OPERATION



5000-013B ASSEMBLY INSTRUCTIONS / PART ID

CASEIH 1063 6 ROW

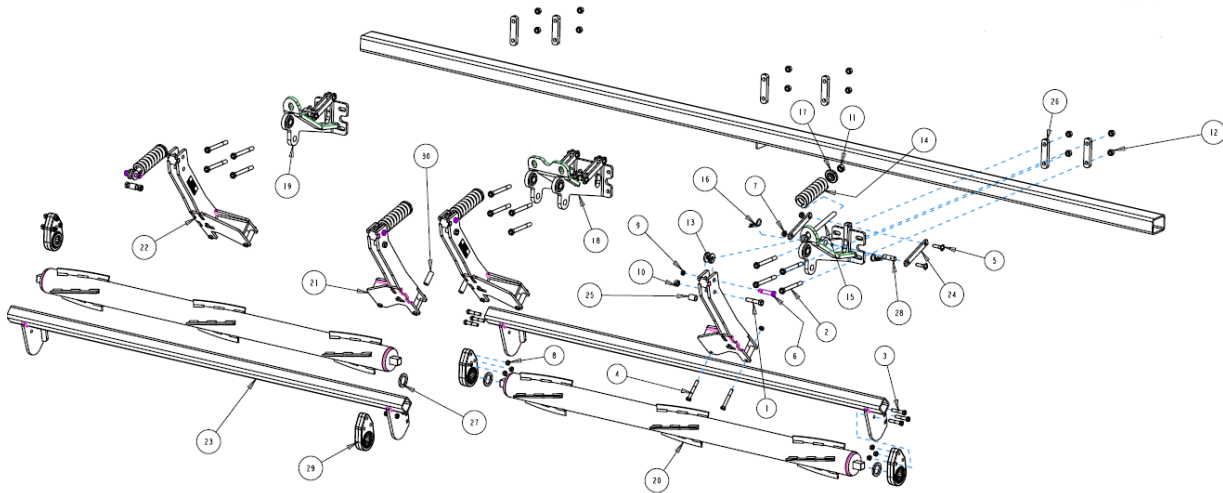

ITEM	PART #	DESCRIPTION	QTY
1	2502-325	5/8-11 X 3 CAP SCREW GRADE 5	4
2	2502-352	5/8-11 X 6 CAP SCREW GRADE 8	12
3	2502-353	1/2-13 X 2.5 CAP SCREW GRADE 8	12
4	2502-365	1/2-13 X 3.75 CAP SCREW GRADE 5	8
5	2505-345	1/2-13 X 2 CARRIAGE BOLT GRADE 5	8
6	2510-121	5/8 SHOULDER BOLT THREAD 1/2-13	4
7	2520-361	1/2-13 FLANGE HEX NUT GRADE 5	8
8	2520-362	1/2-13 LOCK HEX NUT GRADE 8	20
9	2520-364	1/2-13 HEX JAM NUT	4
10	2520-459	5/8-11 LOCK HEX NUT GRADE 5	4
11	2520-515	3/4-10 LOCK HEX NUT GRADE 2	4
12	2520-603	5/8-11 TOP LOCK HEX NUT GRADE 8	12
13	2526-449	5/8 FLAT WASHER 1/4" THICK	8
14	2550-709	1/2" WIRE 2.5" OD X 1.5" ID X 7.25" LONG COMPRESSION SPRING	4
15	2570-126	3/4 X 10 EYE BOLT	4
16	2570-465	HAIRPIN	8
17	2975-302	SPRING BUSHING	4
18	5000-201	DOUBLE MOUNT BRACKET	1
	2528-369	SLEEVE	2/MOUNT
19	5000-202	SINGLE MOUNT BRACKET	2
	2528-369	SLEEVE	1/MOUNT
20	5000-211B	ROLLER 76"	2
21	5000-256	LEFT HAND ARM 19"	2
22	5000-259	RIGHT HAND ARM 19"	2
23	5000-261	ROLLER MOUNT 3 ROW LONG	2
24	5000-309	SUPPORT STRAP	8
25	5000-318	PIVOT BUSHING	4
26	5000-319	MOUNT STRAP	6
27	5000-322	SHIM WASHER	4
28	5000-323	LOCK UP PIN	4
29	5000-355	BEARING ASSEMBLY	4
	2550-059	BEARING	4
30	5000-378	SPACER BUSHING	8

5000-014C ASSEMBLY INSTRUCTIONS / PART ID

CASEIH 1083 8 ROW

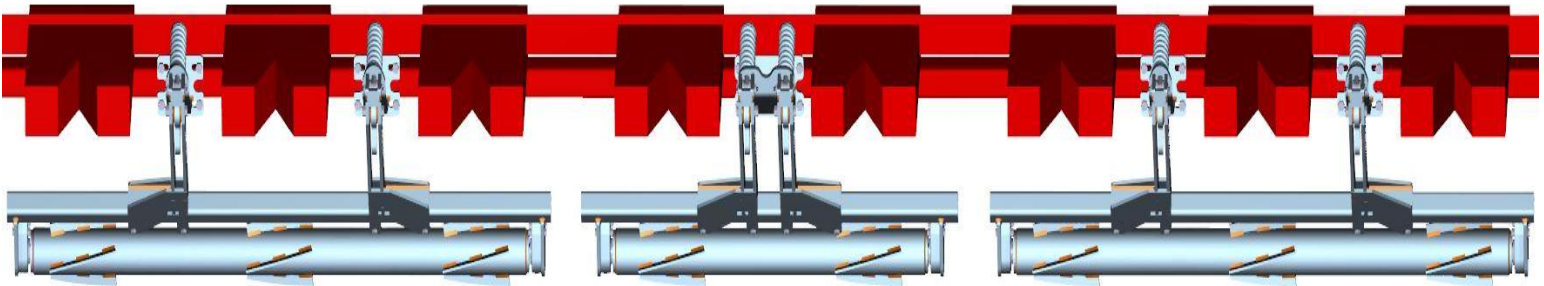

Step 1: Install each 5000-202 single mount & 5000-201 double mount to the corn head frame, using 4) 5/8" X 6" bolts, 2) 5000-319 mount straps, & 4) 5/8" lock nuts per mount. Single mount locations will be between rows 1 & 2, 2 & 3, 6 & 7, and 7 & 8.

The double mount will be located between rows 4 & 5.

Step 2: Install 2) 5000-309 support straps on each single mount & 4) 5000-309 support straps on the double mount. Use 2) 1/2" – 13 X 2" carriage bolts & 2) 1/2" – 13 flange whiz lock nuts to attach the support straps to each single mount & use 4) 1/2" – 13 x 2" carriage bolts & 4) 1/2" – 13 flange whiz lock nuts to attach the support straps to the double mount. Install the 5000-323 lock up pin in the storage location & secure each in place with 2) 7 gauge cotter hairpin.

Step 3: Install 1) 5000-318 pivot bushing in each single mount & 2) 5000-318 pivot bushings in the double mount. Attach 1) 5000-256 LH over bearing arm to the single mount between rows 2 & 3 and 7 & 8. Install 1) 5000-259 RH over bearing arm on the double mount to the side that is closest to row 4. Install 1) 5000-256 LH over bearing arm to the double mount to the side that is closest to row 5. Install 1) 5000-259 RH over bearing arm to the single mount between rows 1 & 2 and 6 & 7. Align the lower hole on each arm with the pivot bushing and insert a 5/8" X 3" bolt through & fasten with a 5/8" lock nut.

Step 4: Install 1) 2570-126 3/4" X 10" eyebolt to each single mount & 2) 2570-126 3/4" X 10" eyebolt to the double mount. Attach each over bearing arm to each eyebolt using 1) 2510-121 5/8" diameter shoulder bolt, 2) 2526-449 5/8" flat washers, & 1) 2520-364 1/2" jam lock nut. The 5/8" flat washers go on each side of the eyebolt & inside the arm channel. The shoulder bolt should be inserted through the top hole on each arm. Only tighten the 1/2" jam lock nut until it makes slight contact with the over bearing arm.

Step 5: Install the 2550-709 compression spring over each eyebolt, place the 2975-302 spring bushing over the eyebolt & onto the compression spring, & secure with the 2520-511 3/4" lock nut. Tighten the lock nut to be flush with the end of the eyebolt.

Step 6: Install each 3 row roller mount. For rows 1 – 3, slide the roller mount into place between the plates on the over bearing arm between rows 1 & 2 and 2 & 3. Use 2) 5000-378 spacer bushings, 2) 1/2" X 3 3/4" bolts, & 2) 1/2" lock nuts to attach the roller mount tube to each arm clamp. Repeat this process to attach the roller mount for rows 6 – 8 using the over bearing arm between rows 6 & 7 and 7 & 8. Install the 2 row roller mount to the over bearing arms between rows 4 & 5. Do not tighten each roller mount into place until after the roller is installed so you can center the roller if needed. Make sure the bearing support is on the back side of the roller mount tab.

Step 7: Attach each roller to the roller mount using 2) 5000-322 shim washers, 2) 5000-355 bearing assemblies, 6) 1/2" X 2 1/2" bolts, & 6) 1/2" lock nuts per roller.

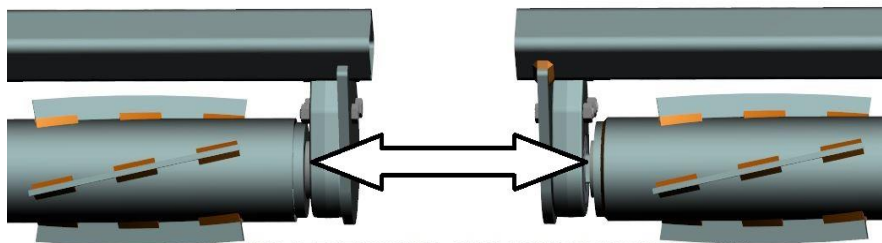

THE SIDE OF THE BEARING ASSEMBLY WHERE THE BEARING IS PROTRUDING MUST BE INSTALLED TOWARD THE ROLLER!

NOTE: BEARING HOUSING SHOULD BE LUBRICATED WITH POLYUREA GREASE BEFORE USE AND THEN EVERY 100 HOURS OF OPERATION



5000-014C ASSEMBLY INSTRUCTIONS / PART ID

CASEIH 1083 8 ROW

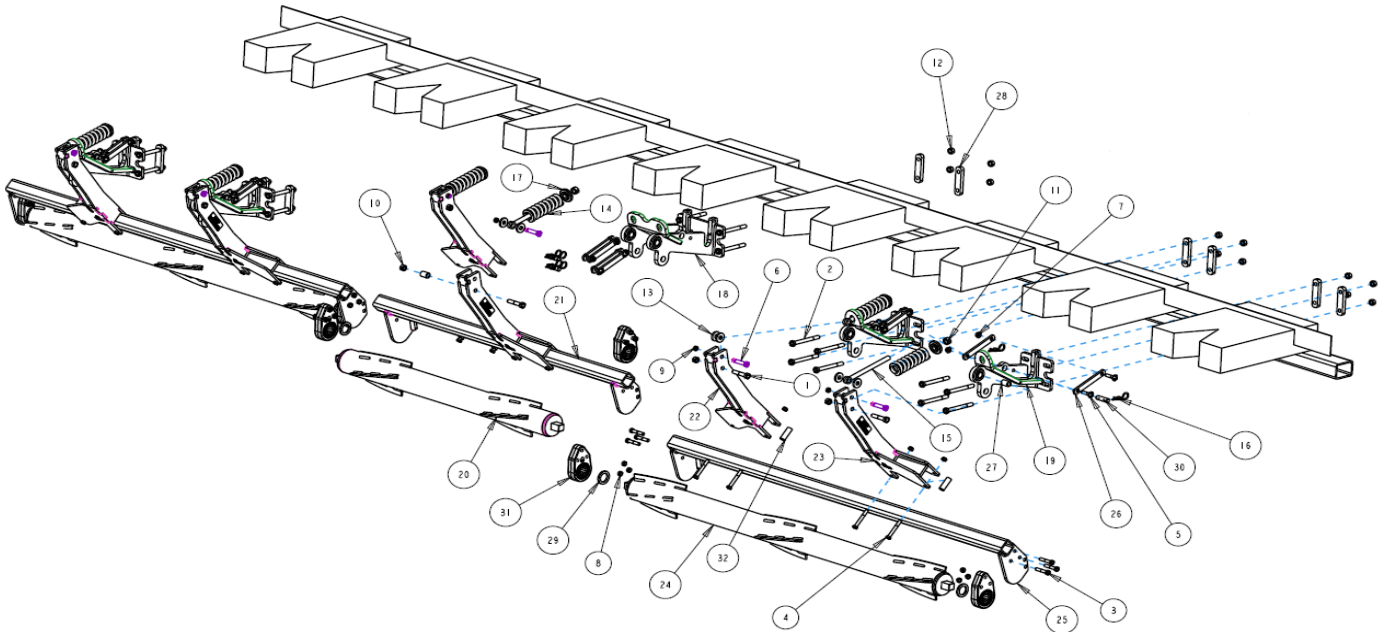

ITEM	PART #	DESCRIPTION	QTY
1	2502-325	5/8-11 X 3 CAP SCREW GRADE 5	6
2	2502-352	5/8-11 X 6 CAP SCREW GRADE 8	20
3	2502-353	1/2-13 X 2.5 CAP SCREW GRADE 8	18
4	2502-365	1/2-13 X 3.75 CAP SCREW GRADE 5	12
5	2505-345	1/2-13 X 2 CARRIAGE BOLT GRADE 5	12
6	2510-121	5/8 SHOULDER BOLT THREAD 1/2-13	6
7	2520-361	1/2-13 FLANGE HEX NUT GRADE 5	12
8	2520-362	1/2-13 LOCK HEX NUT GRADE 8	30
9	2520-364	1/2-13 HEX JAM NUT	6
10	2520-459	5/8-11 LOCK HEX NUT GRADE 5	6
11	2520-515	3/4-10 LOCK HEX NUT GRADE 2	6
12	2520-603	5/8-11 TOP LOCK HEX NUT GRADE 8	20
13	2526-449	5/8 FLAT WASHER 1/4" THICK	12
14	2550-709	1/2" WIRE 2.5" OD X 1.5" ID X 7.25" LONG COMPRESSION SPRING	6
15	2570-126	3/4 X 10 EYE BOLT	6
16	2570-465	HAIRPIN	12
17	2975-302	SPRING BUSHING	6
18	5000-201	DOUBLE MOUNT BRACKET	1
	2528-369	SLEEVE	2/MOUNT
19	5000-202	SINGLE MOUNT BRACKET	4
	2528-369	SLEEVE	1/MOUNT
20	5000-203B	ROLLER 48"	1
21	5000-255	2 ROW ROLLER MOUNT	1
22	5000-256	LEFT HAND ARM 19"	3
23	5000-259	RIGHT HAND ARM 19"	3
24	5000-272	3 ROW ROLLER 71.5"	2
25	5000-275A	3 ROW ROLLER MOUNT	2
26	5000-309	SUPPORT STRAP	12
27	5000-318	PIVOT BUSHING	6
28	5000-319	MOUNT STRAP	10
29	5000-322	SHIM WASHER	6
30	5000-323	LOCK UP PIN	6
31	5000-355	BEARING ASSEMBLY	6
	2550-059	BEARING	6
31	5000-378	SPACER BUSHING	12

5000-015C ASSEMBLY INSTRUCTIONS / PART ID

GERINGHOFF 8 ROW

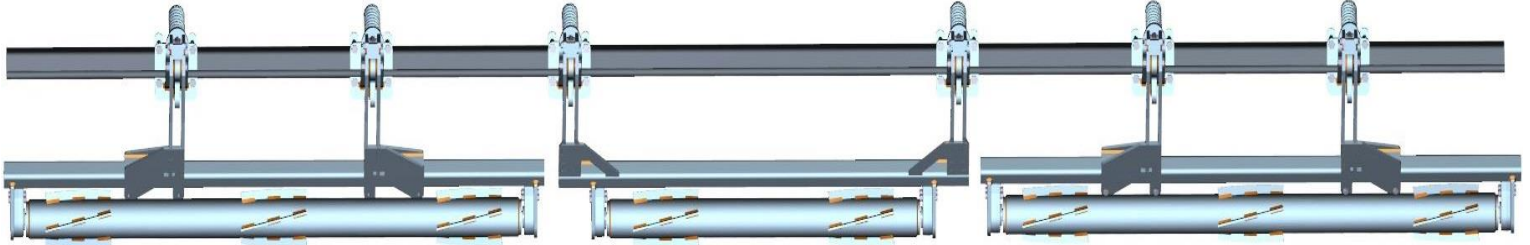

Step 1: Install each 5000-227 single mount using 2) 5000-348 mount straps, 4) 5/8" – 11 X 7" bolts, & 4) 5/8" – 11 lock nuts. Insert the 2 top mounting bolts through the 5000-228 support strap before going through the face plate of the mount. Install 1) 5/8" – 11 X 2 1/2" bolt through open end of the support strap securing to the mating hole on the mount bracket with a 5/8" whiz lock hex nut. Mount bracket locations will be between rows 1 & 2, 2 & 3, 3 & 4, 5 & 6, 6 & 7, and 7 & 8. Install the 5000-323 lock up pin in the storage location & secure each in place with 2) 7 gauge cotter hairpin.

NOTE: ON CERTAIN 8 ROW GERINGHOFF CORN HEADS, THE HYD. CYLINDER & SPRING ASSIST FOR THE DECK PLATE ADJUSTMENT WILL NEED MOVED. APPROXIMATELY 1FT OF HYD. HOSE WILL NEED ADDED TO REACH THE CYLINDER'S NEW LOCATION. CALL YETTER FOR MORE INFO, 1-800-447-5777, & ASK FOR SERVICE DEPARTMENT!

Step 2: Install 1) 5000-318 pivot bushing in each single mount. Attach 1) 5000-256 LH over bearing arm to the single mount between rows 2 & 3 and 7 & 8. Install 1) 5000-259 RH over bearing arm to the single mount between rows 1 & 2 and 6 & 7. Install the 5000-241 wide centered fixed pivot arm to the mount between rows 3 & 4 and 5 & 6. Align the lower hole on each arm with the pivot bushing and insert a 5/8" X 3" bolt through & fasten with a 5/8" lock nut.

Step 3: Install 1) 2570-126 3/4" X 10" eyebolt to each single mount. Attach each over bearing arm to each eyebolt using 1) 2510-121 5/8" diameter shoulder bolt, 2) 2526-449 5/8" flat washers, & 1) 2520-364 1/2" jam lock nut. The 5/8" flat washers go on each side of the eyebolt & inside the arm channel. The shoulder bolt should be inserted through the top hole on each arm. Only tighten the 1/2" jam lock nut until it makes slight contact with the over bearing arm.

Step 4: Install the 2550-709 compression spring over each eyebolt, place the 2975-302 spring bushing over the eyebolt & onto the compression spring, & secure with the 2520-511 3/4" lock nut. Tighten the lock nut to be flush with the end of the eyebolt.

Step 5: Install each 3 row roller mount. For rows 1 – 3, slide the roller mount into place between the plates on the over bearing arm between rows 1 & 2 and 2 & 3. Use 2) 5000-378 spacer bushings, 2) 1/2" X 3 3/4" bolts, & 2) 1/2" lock nuts to attach the roller mount tube to each arm clamp. Repeat this process to attach the roller mount for rows 6 – 8 using the over bearing arm between rows 6 & 7 and 7 & 8. Do not tighten each roller mount into place until after the roller is installed so you can center the roller if needed. Make sure the bearing support is on the back side of the roller mount tab.

Step 6: Attach each roller to the roller mount using 2) 5000-322 shim washers, 2) 5000-355 bearing assemblies, 6) 1/2" X 2 1/2" bolts, & 6) 1/2" lock nuts per roller.

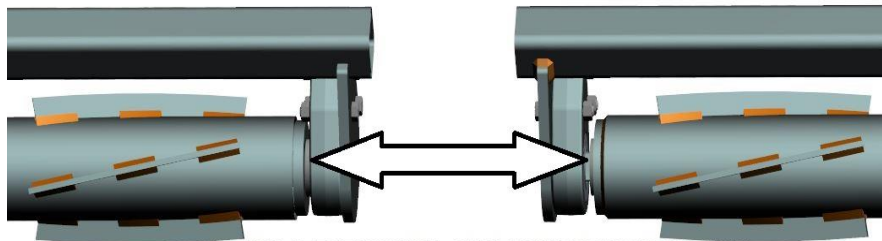

THE SIDE OF THE BEARING ASSEMBLY WHERE THE BEARING IS PROTRUDING MUST BE INSTALLED TOWARD THE ROLLER!

NOTE: BEARING HOUSING SHOULD BE LUBRICATED WITH POLYUREA GREASE BEFORE USE AND THEN EVERY 100 HOURS OF OPERATION



5000-015C ASSEMBLY INSTRUCTIONS / PART ID

GERINGHOFF 8 ROW

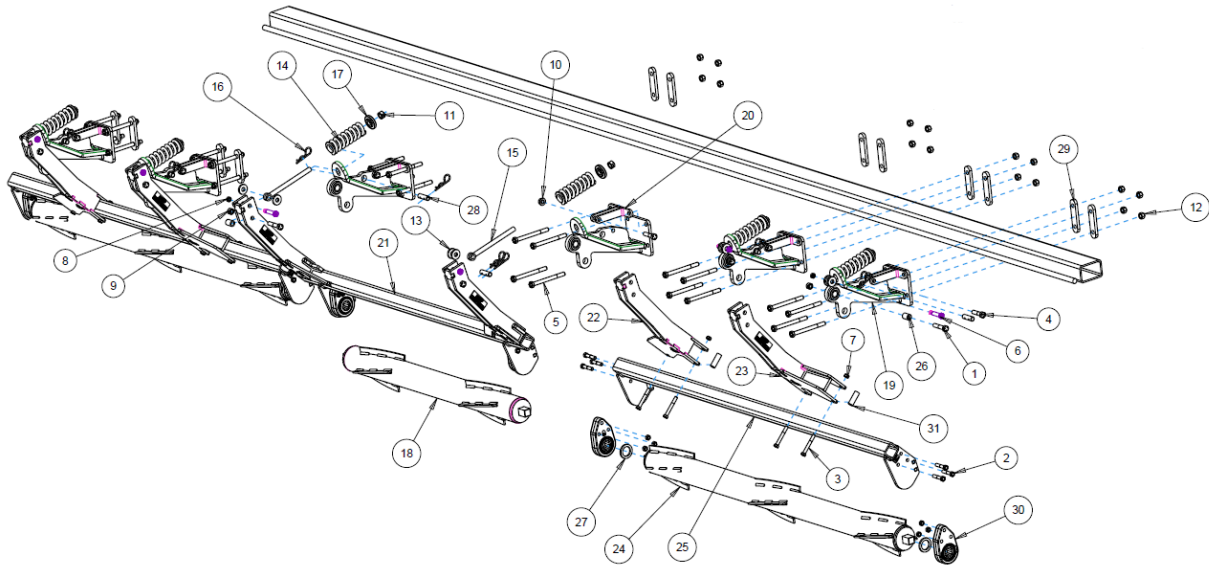

ITEM	PART #	DESCRIPTION	QTY
1	2502-325	5/8-11 X 3 CAP SCREW GRADE 5	6
2	2502-353	1/2-13 X 2.5 CAP SCREW GRADE 8	18
3	2502-365	1/2-13 X 3.75 CAP SCREW GRADE 5	8
4	2502-393	5/8-11 X 2.5 CAP SCREW GRADE 5	6
5	2502-396	5/8-11 X 7 CAP SCREW GRADE 8	24
6	2510-121	5/8 SHOULDER BOLT THREAD 1/2-13	6
7	2520-362	1/2-13 LOCK HEX NUT GRADE 8	26
8	2520-364	1/2-13 HEX JAM NUT	6
9	2520-459	5/8-11 LOCK HEX NUT GRADE 5	6
10	2520-465	5/8-11 FLANGE NUT GRADE 8	6
11	2520-515	3/4-10 LOCK HEX NUT GRADE 2	6
12	2520-603	5/8-11 TOP LOCK HEX NUT GRADE 8	24
13	2526-449	5/8 FLAT WASHER 1/4" THICK	12
14	2550-709	1/2" WIRE 2.5" OD X 1.5" ID X 7.25" LONG COMPRESSION SPRING	6
15	2570-126	3/4 X 10 EYE BOLT	6
16	2570-465	HAIRPIN	12
17	2975-302	SPRING BUSHING	6
18	5000-203B	ROLLER 48"	1
19	5000-227	MOUNT BRACKET GERINGHOFF	6
20	5000-228	SUPPORT STRAP GERINGHOFF	6
21	5000-241	WIDE PIVOT ARM 2 ROW	1
22	5000-256	LEFT HAND ARM 19"	2
23	5000-259	RIGHT HAND ARM 19"	2
24	5000-272	3 ROW ROLLER 71.5"	2
25	5000-275A	3 ROW ROLLER MOUNT	2
26	5000-318	PIVOT BUSHING	6
27	5000-322	SHIM WASHER	6
28	5000-323	LOCK UP PIN	6
29	5000-348	MOUNT STRAP GERINGHOFF	12
30	5000-355	BEARING ASSEMBLY	6
	2550-059	BEARING	6
31	5000-378	SPACER BUSHING	8

5000-016C ASSEMBLY INSTRUCTIONS / PART ID

GERINGHOFF 12 ROW

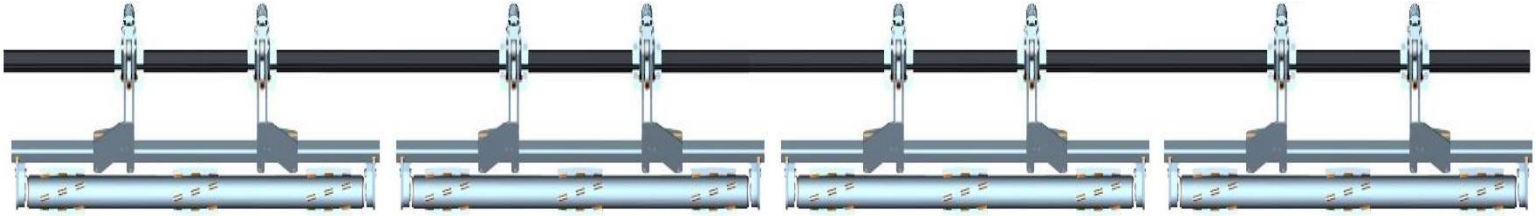

Step 1: Install each 5000-227 single mount using 2) 5000-348 mount straps, 4) 5/8" – 11 X 7" bolts, & 4) 5/8" – 11 lock nuts. Insert the 2 top mounting bolts through the 5000-228 support strap before going through the face plate of the mount. Install 1) 5/8" – 11 X 2 1/2" bolt through open end of the support strap securing to the mating hole on the mount bracket with a 5/8" whiz lock hex nut. Mount bracket locations will be between rows 1 & 2, 2 & 3, 4 & 5, 5 & 6, 7 & 8, 8 & 9, 10 & 11, and 11 & 12. Install the 5000-323 lock up pin in the storage location & secure each in place with 2) 7 gauge cotter hairpin.

NOTE: ON CERTAIN 12 ROW GERINGHOFF CORN HEADS, THE HYD. CYLINDER & SPRING ASSIST FOR THE DECK PLATE ADJUSTMENT WILL NEED MOVED. APPROXIMATELY 1FT OF HYD. HOSE WILL NEED ADDED TO REACH THE CYLINDER'S NEW LOCATION. CALL YETTER FOR MORE INFO, 1-800-447-5777, & ASK FOR SERVICE DEPARTMENT!

Step 2: Install 1) 5000-318 pivot bushing in each single mount. Attach 1) 5000-256 LH over bearing arm to the single mount between rows 2 & 3, 5 & 6, 8 & 9, and 11 & 12. Install 1) 5000-259 RH over bearing arm to the single mount between rows 1 & 2, 4 & 5, 7 & 8, and 10 & 11. Align the lower hole on each arm with the pivot bushing and insert a 5/8" X 3" bolt through & fasten with a 5/8" lock nut.

Step 3: Install 1) 2570-126 3/4" X 10" eyebolt to each single mount. Attach each over bearing arm to each eyebolt using 1) 2510-121 5/8" diameter shoulder bolt, 2) 2526-449 5/8" flat washers, & 1) 2520-364 1/2" jam lock nut. The 5/8" flat washers go on each side of the eyebolt & inside the arm channel. The shoulder bolt should be inserted through the top hole on each arm. Only tighten the 1/2" jam lock nut until it makes slight contact with the over bearing arm.

Step 4: Install the 2550-709 compression spring over each eyebolt, place the 2975-302 spring bushing over the eyebolt & onto the compression spring, & secure with the 2520-511 3/4" lock nut. Tighten the lock nut to be flush with the end of the eyebolt.

Step 5: Install each 3 row roller mount. For rows 1 – 3, slide the roller mount into place between the plates on the over bearing arm between rows 1 & 2 and 2 & 3. Use 2) 5000-378 spacer bushings, 2) 1/2" X 3 3/4" bolts, & 2) 1/2" lock nuts to attach the roller mount tube to each arm clamp. Repeat this process to attach the roller mount for rows 4 – 6, 7 – 9, & 10 – 12. Do not tighten each roller mount into place until after the roller is installed so you can center the roller if needed. Make sure the bearing support is on the back side of the roller mount tab.

Step 6: Attach each roller to the roller mount using 2) 5000-322 shim washers, 2) 5000-355 bearing assemblies, 6) 1/2" X 2 1/2" bolts, & 6) 1/2" lock nuts per roller.

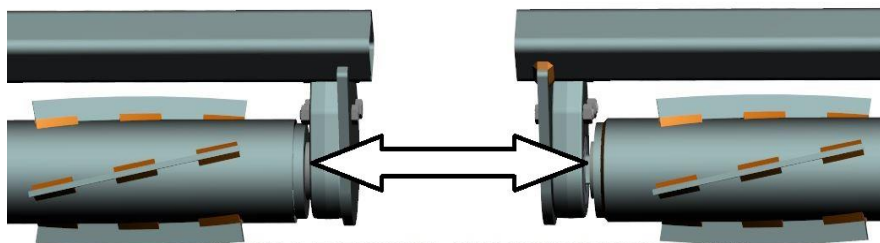

THE SIDE OF THE BEARING ASSEMBLY WHERE THE BEARING IS PROTRUDING MUST BE INSTALLED TOWARD THE ROLLER!

NOTE: BEARING HOUSING SHOULD BE LUBRICATED WITH POLYUREA GREASE BEFORE USE AND THEN EVERY 100 HOURS OF OPERATION



5000-016C ASSEMBLY INSTRUCTIONS / PART ID

GERINGHOFF 12 ROW

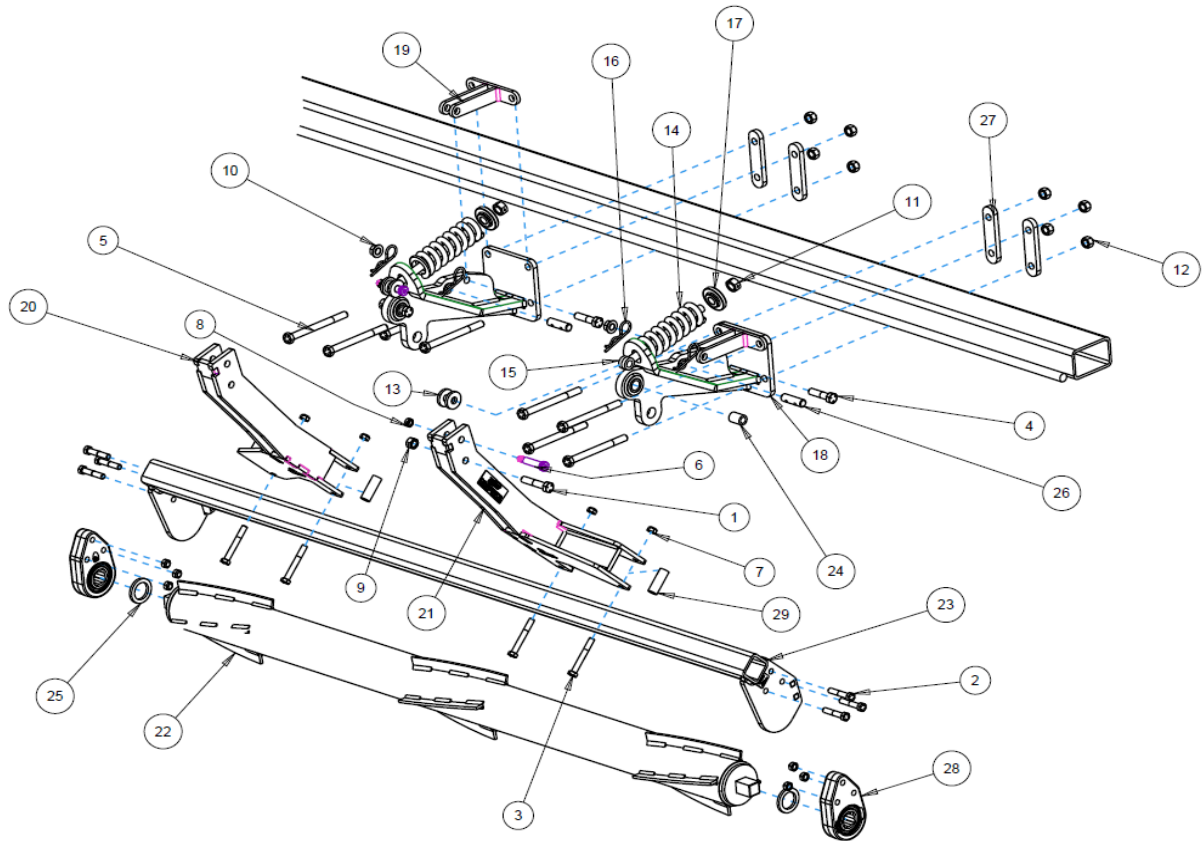

ITEM	PART #	DESCRIPTION	QTY
1	2502-325	5/8-11 X 3 CAP SCREW GRADE 5	8
2	2502-353	1/2-13 X 2.5 CAP SCREW GRADE 8	24
3	2502-365	1/2-13 X 3.75 CAP SCREW GRADE 5	16
4	2502-393	5/8-11 X 2.5 CAP SCREW GRADE 5	8
5	2502-396	5/8-11 X 7 CAP SCREW GRADE 8	32
6	2510-121	5/8 SHOULDER BOLT THREAD 1/2-13	8
7	2520-362	1/2-13 LOCK HEX NUT GRADE 8	40
8	2520-364	1/2-13 HEX JAM NUT	8
9	2520-459	5/8-11 LOCK HEX NUT GRADE 5	8
10	2520-465	5/8-11 FLANGE NUT GRADE 8	8
11	2520-515	3/4-10 LOCK HEX NUT GRADE 2	8
12	2520-603	5/8-11 TOP LOCK HEX NUT GRADE 8	32
13	2526-449	5/8 FLAT WASHER 1/4" THICK	16
14	2550-709	1/2" WIRE 2.5" OD X 1.5" ID X 7.25" LONG COMPRESSION SPRING	8
15	2570-126	3/4 X 10 EYE BOLT	8
16	2570-465	HAIRPIN	16
17	2975-302	SPRING BUSHING	8
18	5000-227	MOUNT BRACKET GERINGHOFF	8
19	5000-228	SUPPORT STRAP GERINGHOFF	8
20	5000-256	LEFT HAND ARM 19"	4
21	5000-259	RIGHT HAND ARM 19"	4
22	5000-272	3 ROW ROLLER 71.5"	4
23	5000-275A	3 ROW ROLLER MOUNT	4
24	5000-318	PIVOT BUSHING	8
25	5000-322	SHIM WASHER	8
26	5000-323	LOCK UP PIN	8
27	5000-348	MOUNT STRAP GERINGHOFF	16
28	5000-355	BEARING ASSEMBLY	8
	2550-059	BEARING	8
29	5000-378	SPACER BUSHING	16

5000-017D ASSEMBLY INSTRUCTIONS / PART ID

DRAGO 830 ROW

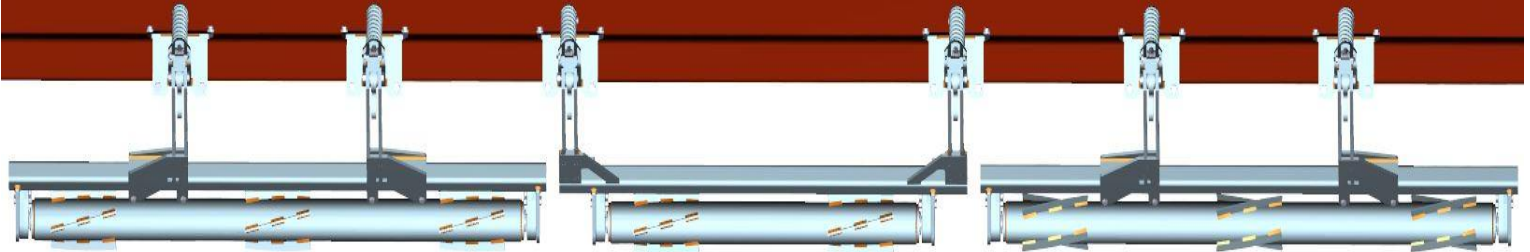

Step 1: Attach each 5000-218 Drago mount brackets to the frame using 2) 5/8" X 3" bolts & 2) 5000-340 clamp blocks for the bottom set of holes & 2) 1/2" X 2 bolts, 2) 5000-339 mount plate washers, & 2) 1/2" hex flange lock nuts for the top set of holes. Mounting brackets should be located between rows 1 & 2, 2 & 3, 3 & 4, 5 & 6, 6 & 7, and 7 & 8. Install the 5000-323 lock up pin in the storage location & secure each in place with 2) 7 gauge cotter hairpin.

Step 2: Install 1) 5000-318 pivot bushing in each mount. Attach 1) 5000-259 RH over bearing arm to each mount between rows 1 & 2 and 6 & 7. Attach 1) 5000-256 LH over bearing arm to each mount between rows 2 & 3 and 7 & 8. Install the 5000-241 wide centered fixed pivot arm to the mount between rows 3 & 4 and 5 & 6. Align the lower hole on each arm with the pivot bushing and insert a 5/8" X 3" bolt through & fasten with a 5/8" lock nut.

Step 3: Install 1) 2570-126 3/4" X 10" eyebolt to each mount. Attach each over bearing arm to the eyebolt using 1) 2510-121 5/8" diameter shoulder bolt, 2) 2526-449 5/8" flat washers, & 1) 2520-364 1/2" jam lock nut. The 5/8" flat washers go on each side of the eyebolt & inside the arm channel. The shoulder bolt should be inserted through the top hole on each arm. Only tighten the 1/2" jam lock nut until it makes slight contact with the over bearing arm.

Step 4: Install the 2550-709 compression spring over each eyebolt, place the 2975-302 spring bushing over the eyebolt & onto the compression spring, & secure with the 2520-511 3/4" lock nut. Tighten the lock nut to be flush with the end of the eyebolt.

Step 5: Install each 3 row roller mount. For rows 1 – 3, slide the roller mount into place between the plates on the over bearing arm between rows 1 & 2 and 2 & 3. Use 2) 5000-378 spacer bushings, 2) 1/2" X 3 3/4" bolts, & 2) 1/2" lock nuts to attach the roller mount tube to each arm clamp. Repeat this process to attach the roller mount for rows 6 – 8 using the over bearing arm between rows 6 & 7 and 7 & 8. Do not tighten each roller mount into place until after the roller is installed so you can center the roller if needed. Make sure the bearing support is on the back side of the roller mount tab.

Step 6: Attach each roller to the roller mount using 2) 5000-322 shim washers, 2) 5000-355 bearing assemblies, 6) 1/2" X 2 1/2" bolts, & 6) 1/2" lock nuts per roller.

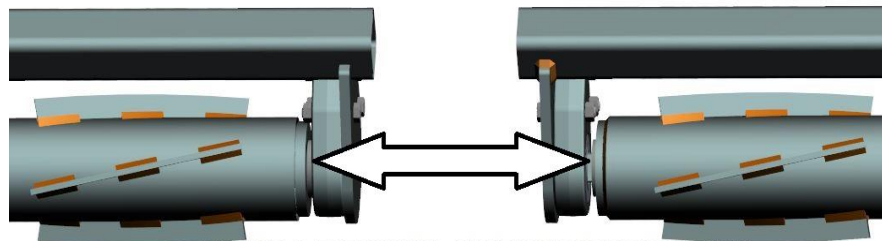

THE SIDE OF THE BEARING ASSEMBLY WHERE THE BEARING IS PROTRUDING MUST BE INSTALLED TOWARD THE ROLLER!

NOTE: BEARING HOUSING SHOULD BE LUBRICATED WITH POLYUREA GREASE BEFORE USE AND THEN EVERY 100 HOURS OF OPERATION



5000-017C ASSEMBLY INSTRUCTIONS / PART ID

DRAGO 830 ROW

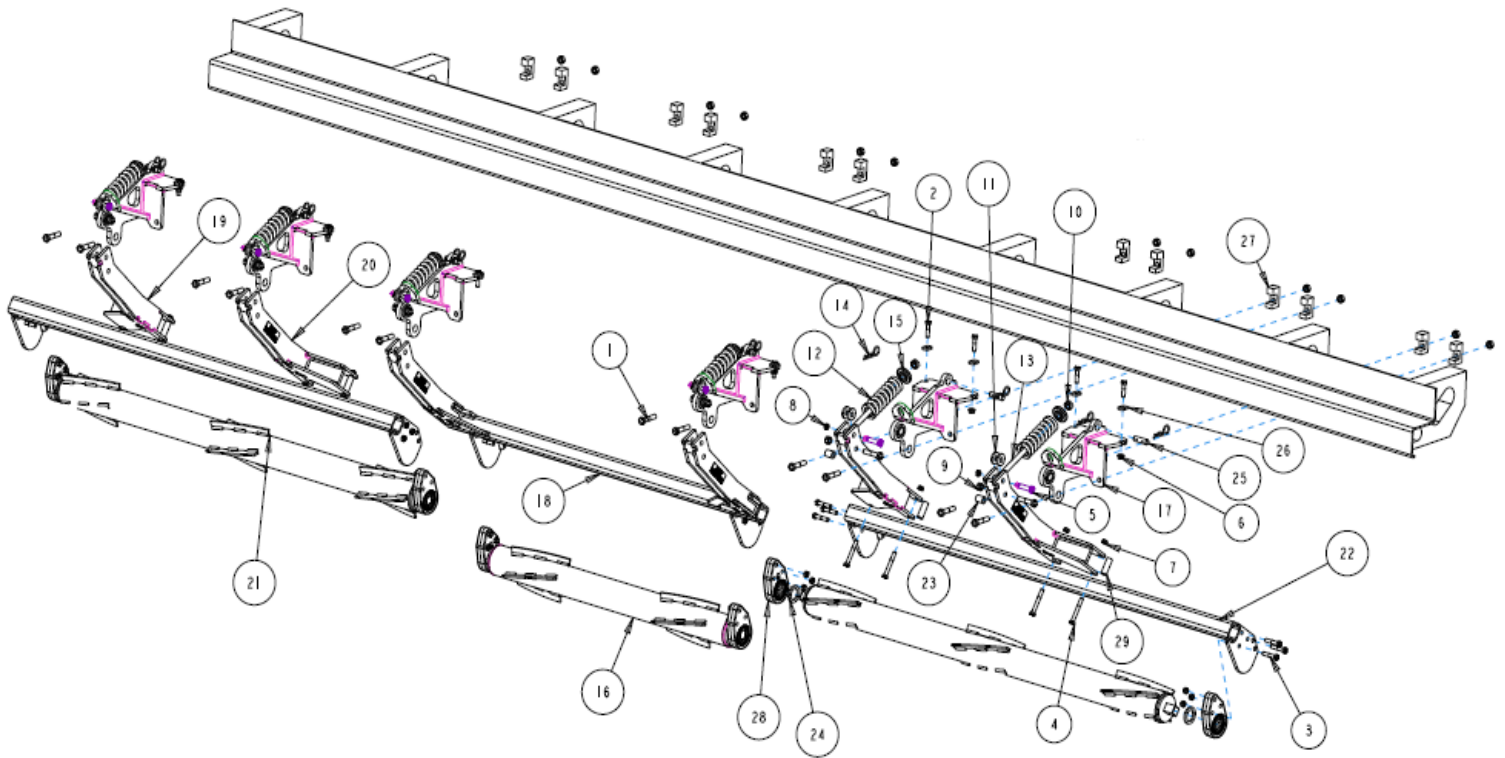

ITEM	PART #	DESCRIPTION	QTY
1	2502-325	5/8-11 X 3 CAP SCREW GRADE 5	18
2	2502-351	1/2-13 X 2 CAP SCREW GRADE 5	12
3	2502-353	1/2-13 X 2.5 CAP SCREW GRADE 8	18
4	2502-365	1/2-13 X 3.75 CAP SCREW GRADE 5	8
5	2510-121	5/8 SHOULDER BOLT THREAD 1/2-13	6
6	2520-361	1/2-13 FLANGE HEX NUT GRADE 5	21
7	2520-362	1/2-13 LOCK HEX NUT GRADE 8	26
8	2520-364	1/2-13 HEX JAM NUT	6
9	2520-459	5/8-11 LOCK HEX NUT GRADE 5	18
10	2520-515	3/4-10 LOCK HEX NUT GRADE 2	6
11	2526-449	5/8 FLAT WASHER 1/4" THICK	12
12	2550-709	1/2" WIRE 2.5" OD X 1.5" ID X 7.25" LONG COMPRESSION SPRING	6
13	2570-126	3/4 X 10 EYE BOLT	6
14	2570-465	HAIRPIN	12
15	2975-302	SPRING BUSHING	6
16	5000-203B	ROLLER 48"	1
17	5000-218B	MOUNT BRACKET DRAGO	6
	2528-369	SLEEVE	1/MOUNT
18	5000-241	WIDE PIVOT ARM	1
19	5000-256	LEFT HAND ARM 19"	2
20	5000-259	RIGHT HAND ARM 19"	2
21	5000-272	ROLLER 3 ROW 30	2
22	5000-275A	ROLLER MOUNT 3 ROW	2
23	5000-318	PIVOT BUSHING	6
24	5000-322	SHIM WASHER	6
25	5000-323	LOCK UP PIN	6
26	5000-339	CLIPPED WASHER	12
27	5000-340	CLAMP BLOCK	12
28	5000-355	BEARING ASSEMBLY	6
	2550-059	BEARING	6
29	5000-378	SPACER BUSHING	8

5000-018D ASSEMBLY INSTRUCTIONS / PART ID

DRAGO 1230 ROW

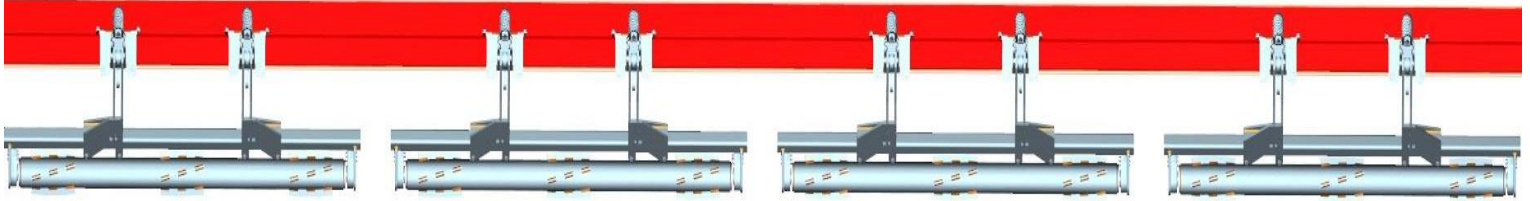

Step 1: Attach each 5000-218 Drago mount brackets to the frame using 2) 5/8" X 3" bolts & 2) 5000-340 clamp blocks for the bottom set of holes & 2) 1/2" X 2" bolts, 2) 5000-339 mount plate washers, & 2) 1/2" hex flange lock nuts for the top set of holes. Mounting brackets should be located between rows 1 & 2, 2 & 3, 4 & 5, 5 & 6, 7 & 8, 8 & 9, 10 & 11, and 11 & 12. Install the 5000-323 lock up pin in the storage location & secure each in place with 2) 7 gauge cotter hairpin.

Step 2: Install 1) 5000-318 pivot bushing in each mount. Attach 1) 5000-259 RH over bearing arm to each mount between rows 1 & 2, 4 & 5, 7 & 8, and 10 & 11. Attach 1) 5000-256 LH over bearing arm to each mount between rows 2 & 3, 5 & 6, 8 & 9, and 11 & 12. Align the lower hole on each arm with the pivot bushing and insert a 5/8" X 3" bolt through & fasten with a 5/8" lock nut.

Step 3: Install 1) 2570-126 3/4" X 10" eyebolt to each mount. Attach each over bearing arm to the eyebolt using 1) 2510-121 5/8" diameter shoulder bolt, 2) 2526-449 5/8" flat washers, & 1) 2520-364 1/2" jam lock nut. The 5/8" flat washers go on each side of the eyebolt & inside the arm channel. The shoulder bolt should be inserted through the top hole on each arm. Only tighten the 1/2" jam lock nut until it makes slight contact with the over bearing arm.

Step 4: Install the 2550-709 compression spring over each eyebolt, place the 2975-302 spring bushing over the eyebolt & onto the compression spring, & secure with the 2520-511 3/4" lock nut. Tighten the lock nut to be flush with the end of the eyebolt.

Step 5: Install each 3 row roller mount. For rows 1 – 3, slide the roller mount into place between the plates on the over bearing arm between rows 1 & 2 and 2 & 3. Use 2) 5000-378 spacer bushings, 2) 1/2" X 3 3/4" bolts, & 2) 1/2" lock nuts to attach the roller mount tube to each arm clamp. Repeat this process to attach the roller mount for rows 4 – 6 using the over bearing arm between rows 4 & 5 and 5 & 6, rows 7 – 9 using the over bearing arm between rows 7 & 8 and 8 & 9, & rows 10 – 12 using the over bearing arm between rows 10 & 11 and 11 & 12. Do not tighten each roller mount into place until after the roller is installed so you can center the roller if needed. Make sure the bearing support is on the back side of the roller mount tab.

Step 6: Attach each 5000-211B 3 row roller to the roller mount using 2) 5000-322 shim washers, 2) 5000-355 bearing assemblies, 6) 1/2" X 2 1/2" bolts, & 6) 1/2" lock nuts per roller.

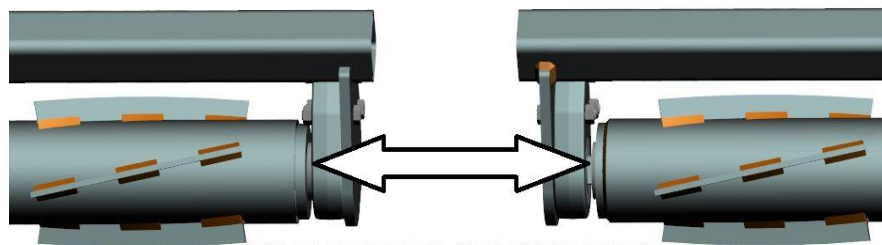

THE SIDE OF THE BEARING ASSEMBLY WHERE THE BEARING IS PROTRUDING MUST BE INSTALLED TOWARD THE ROLLER!

NOTE: BEARING HOUSING SHOULD BE LUBRICATED WITH POLYUREA GREASE BEFORE USE AND THEN EVERY 100 HOURS OF OPERATION



5000-018D ASSEMBLY INSTRUCTIONS / PART ID

DRAGO 1230 ROW

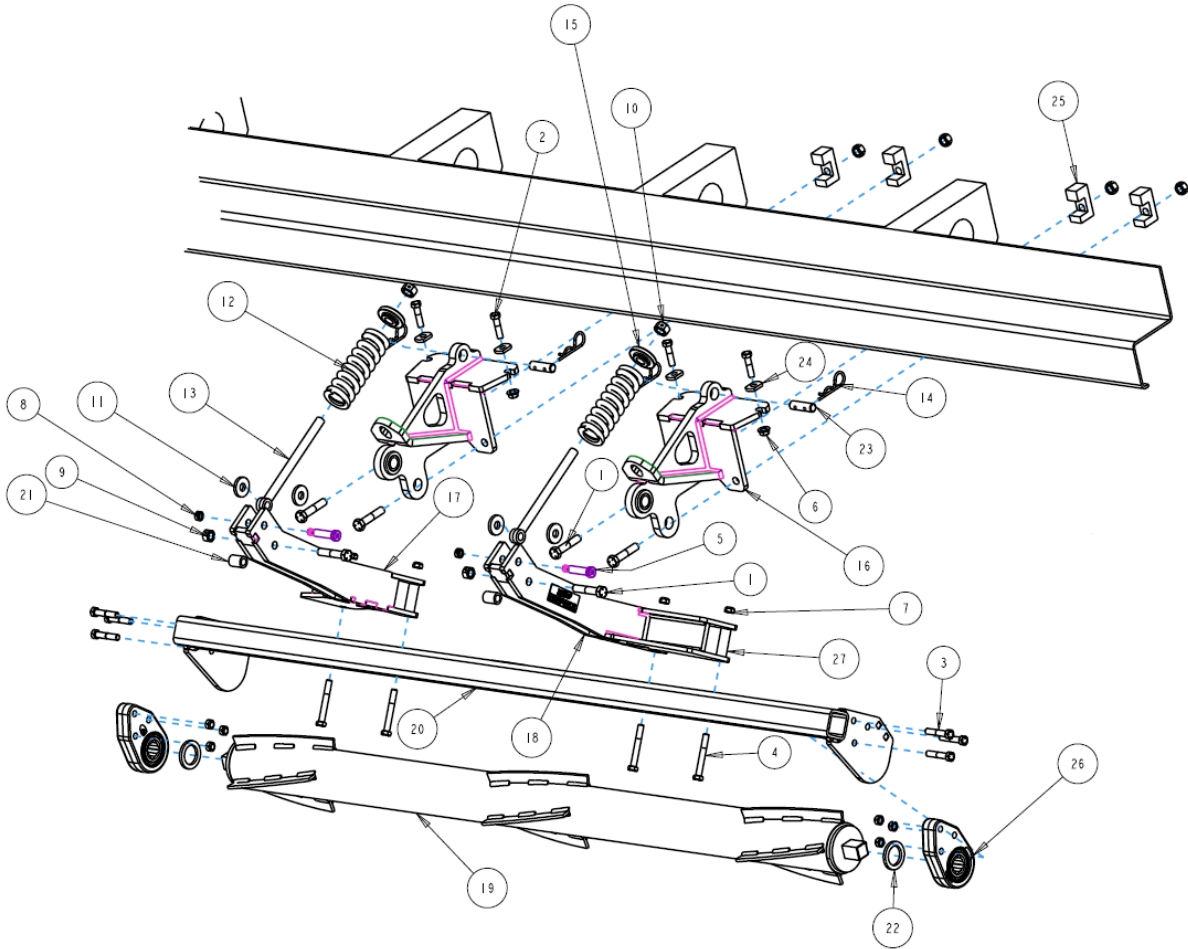

ITEM	PART #	DESCRIPTION	QTY
1	2502-325	5/8-11 X 3 CAP SCREW GRADE 5	24
2	2502-351	1/2-13 X 2 CAP SCREW GRADE 5	16
3	2502-353	1/2-13 X 2.5 CAP SCREW GRADE 8	24
4	2502-365	1/2-13 X 3.75 CAP SCREW GRADE 5	16
5	2510-121	5/8 SHOULDER BOLT THREAD 1/2-13	8
6	2520-361	1/2-13 FLANGE HEX NUT GRADE 5	16
7	2520-362	1/2-13 LOCK HEX NUT GRADE 8	40
8	2520-364	1/2-13 HEX JAM NUT	8
9	2520-459	5/8-11 LOCK HEX NUT GRADE 5	24
10	2520-515	3/4-10 LOCK HEX NUT GRADE 2	8
11	2526-449	5/8 FLAT WASHER 1/4" THICK	16
12	2550-709	1/2" WIRE 2.5" OD X 1.5" ID X 7.25" LONG COMPRESSION SPRING	8
13	2570-126	3/4 X 10 EYE BOLT	8
14	2570-465	HAIRPIN	16
15	2975-302	SPRING BUSHING	8
16	5000-218B	MOUNT BRACKET DRAGO	8
	2528-369	SLEEVE	1/MOUNT
17	5000-256	LEFT HAND ARM 19"	4
18	5000-259	RIGHT HAND ARM 19"	4
19	5000-272	ROLLER 3 ROW 30	4
20	5000-275A	ROLLER MOUNT 3 ROW	4
21	5000-318	PIVOT BUSHING	8
22	5000-322	SHIM WASHER	8
23	5000-323	LOCK UP PIN	8
24	5000-339	CLIPPED WASHER	16
25	5000-340	CLAMP BLOCK	16
26	5000-355	BEARING ASSEMBLY	8
	2550-059	BEARING	4
27	5000-378	SPACER BUSHING	16

5000-019C ASSEMBLY INSTRUCTIONS / PART ID

CASEIH 2412, 3412 12 ROW

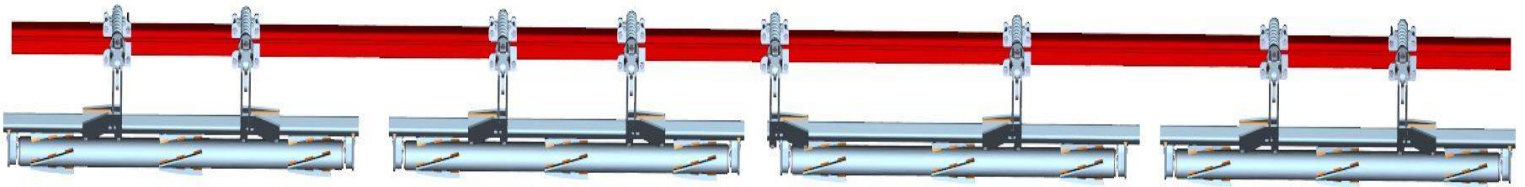

Step 1: Install each 5000-224 single mount to the corn head frame using 4) 5/8" X 6" bolts, 2) 5000-341 mount straps, & 4) 5/8" lock nuts per mount. Substitute 1) 2570-131 5/8" – 11 X 4" X 8" U-Bolt for 1 mount strap & 2 5/8" X 6" bolts on each single mount between rows 1 & 2 and 11 & 12 due to a support gusset prohibiting the strap to fit. Mounting bracket locations will be between rows 1 & 2, 2 & 3, 4 & 5, 6 & 7, 7 & 8, 8 & 9, 10 & 11, and 11 & 12.

Step 2: Install 1) 5000-223 support strap on each mount. Use 2) 1/2" – 13 X 1 1/2" bolts & 2) 1/2" – 13 flange whiz lock nuts to attach the support strap to the top set of holes on the mount plate & use 1) 1/2" – 13 X 2 1/4" bolt & 1) 1/2" – 13 flange whiz lock nut to attach the support strap to the main pivot plate. Install the 5000-323 lock up pin in the storage location & secure each in place with 2) 7 gauge cotter hairpin.

Step 3: Install 1) 5000-318 pivot bushing in each mount. Attach 1) 5000-259 RH over bearing arm to each mount between rows 1 & 2, 6 & 7, 7 & 8, & 10 & 11. Attach 1) 5000-256 LH over bearing arm to each mount between rows 2 & 3, 4 & 5, 8 & 9, & 11 & 12. Align the lower hole on each arm with the pivot bushing & insert a 5/8" X 3" bolt through & fasten with a 5/8" lock nut.

Step 4: Install 1) 2570-126 3/4" X 10" eyebolt to each mount. Attach each over bearing arm to the eyebolt using 1) 2510-121 5/8" diameter shoulder bolt, 2) 2526-449 5/8" flat washers, & 1) 2520-364 1/2" jam lock nut. The 5/8" flat washers go on each side of the eyebolt & inside the arm channel. The shoulder bolt should be inserted through the top hole on each arm. Only tighten the 1/2" jam lock nut until it makes slight contact with the over bearing arm.

Step 5: Install the 2550-709 compression spring over each eyebolt, place the 2975-302 spring bushing over the eyebolt & onto the compression spring, & secure with the 2520-511 3/4" lock nut. Tighten the lock nut to be flush with the end of the eyebolt.

Step 6: Install each 3 row roller mount. For rows 1 – 3, slide the roller mount into place between the plates on the over bearing arm between rows 1 & 2 and 2 & 3. Use 2) 5000-378 spacer bushings, 2) 1/2" X 3 3/4" bolts, & 2) 1/2" lock nuts to attach the roller mount tube to each arm clamp. Repeat this process to attach the roller mount for rows 4 – 6 using the over bearing arm between rows 4 & 5 and 6 & 7, rows 7 – 9 using the over bearing arms between rows 7 & 8 & 8 & 9, & rows 10 -12 using the over bearing arms between rows 10 & 11 & 11 & 12. Do not tighten each roller mount into place until after the roller is installed so you can center the roller if needed. Make sure the bearing support is on the back side of the roller mount tab.

Step 7: Attach each roller to the roller mount using 2) 5000-322 shim washers, 2) 5000-355 bearing assemblies, 6) 1/2" X 2 1/2" bolts, & 6) 1/2" lock nuts per roller.

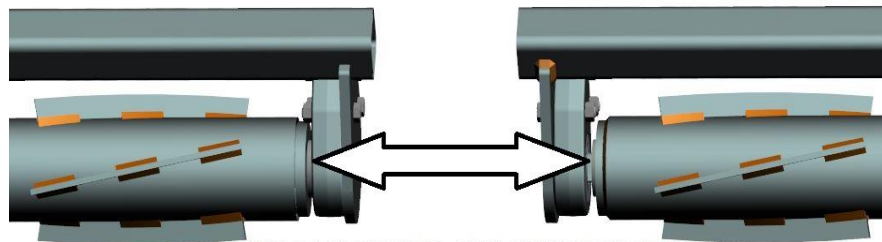

THE SIDE OF THE BEARING ASSEMBLY WHERE THE BEARING IS PROTRUDING MUST BE INSTALLED TOWARD THE ROLLER!

NOTE: BEARING HOUSING SHOULD BE LUBRICATED WITH POLYUREA GREASE BEFORE USE AND THEN EVERY 100 HOURS OF OPERATION



5000-019C ASSEMBLY INSTRUCTIONS / PART ID

CASEIH 2412, 3412 12 ROW

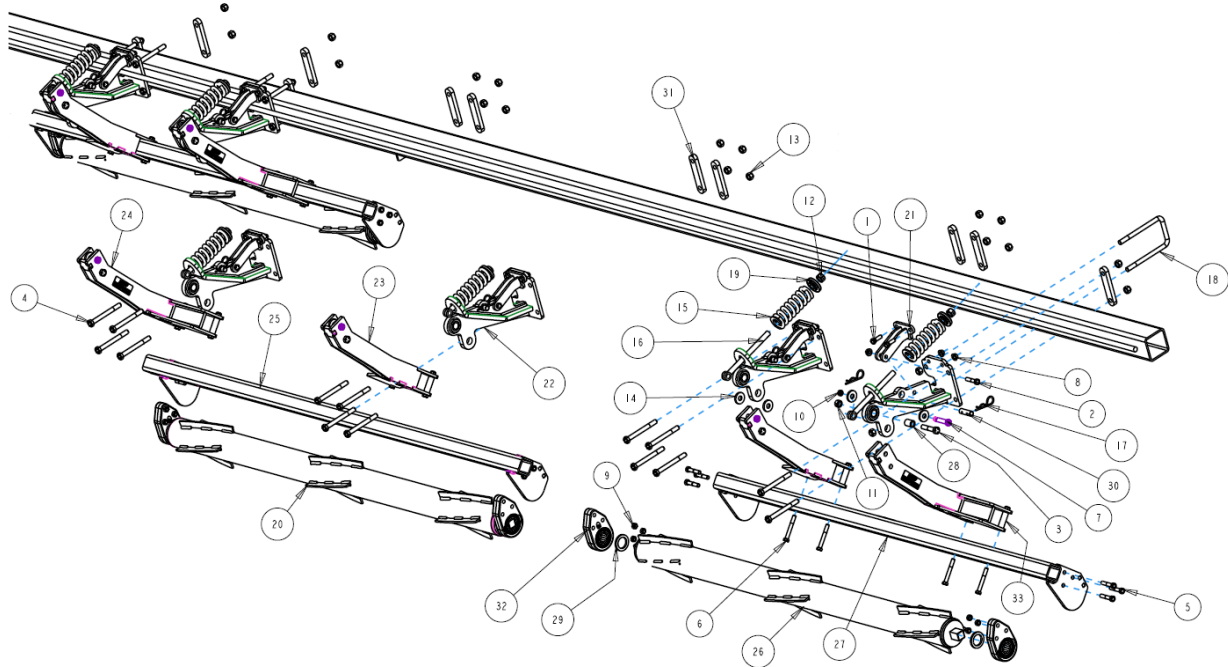

ITEM	PART #	DESCRIPTION	QTY
1	2502-294	1/2-13 X 1.5 CAP SCREW GRADE 5	16
2	2502-314	1/2-13 X 2.25 CAP SCREW GRADE 5	8
3	2502-325	5/8-11 X 3 CAP SCREW GRADE 5	8
4	2502-352	5/8-11 X 6 CAP SCREW GRADE 8	28
5	2502-353	1/2-13 X 2.5 CAP SCREW GRADE 8	24
6	2502-365	1/2-13 X 3.75 CAP SCREW GRADE 5	16
7	2510-121	5/8" DIAMETER SHOULDER, 2 1/4" LONG SHOULDER, 1/2" - 13	8
8	2520-361	1/2-13 FLANGE WHIZ LOCK HEX NUT GRADE 5	24
9	2520-362	1/2-13 HEX LOCK NUT GRADE 8	40
10	2520-364	1/2-13 HEX JAM LOCK NUT	8
11	2520-459	5/8-11 LOCK HEX NUT GRADE 5	8
12	2520-515	3/4-10 LOCK HEX NUT GRADE 2	8
13	2520-603	5/8-11 TOP LOCK HEX NUT GRADE 8	32
14	2526-449	5/8" FLAT WASHER 1/4" THICK	16
15	2550-709	1/2" WIRE 2.50D X 1.51D X 7.25 LONG COMPRESSION SPRING	8
16	2570-126	3/4 X 10 EYEBOLT	8
17	2570-465	HAIRPIN COTTER	16
18	2570-592	5/8-11 X 4 X 8.5 U-BOLT	2
19	2975-302	SPRING BUSHING	8
20	5000-211B	ROLLER 76"	1
21	5000-223	SUPPORT STRAP	8
22	5000-224	MOUNT BRACKET	8
	2528-369	SLEEVE	1/MOUNT
23	5000-256	LEFT HAND ARM 19"	4
24	5000-259	RIGHT HAND ARM 19"	4
25	5000-261	ROLLER MOUNT, LONG	1
26	5000-272	ROLLER 71.5"	3
27	5000-275A	ROLLER MOUNT SHORT	3
28	5000-318	PIVOT BUSHING	8
29	5000-322	SHIM WASHER	8
30	5000-323	LOCK UP PIN	8
31	5000-341	MOUNT STRAP	14
32	5000-355	BEARING ASSEMBLY	8
	2550-059	BEARING	8
33	5000-378	SPACER BUSHING	16

5000-021C ASSEMBLY INSTRUCTIONS / PART ID

GERINGHOFF 6 ROW

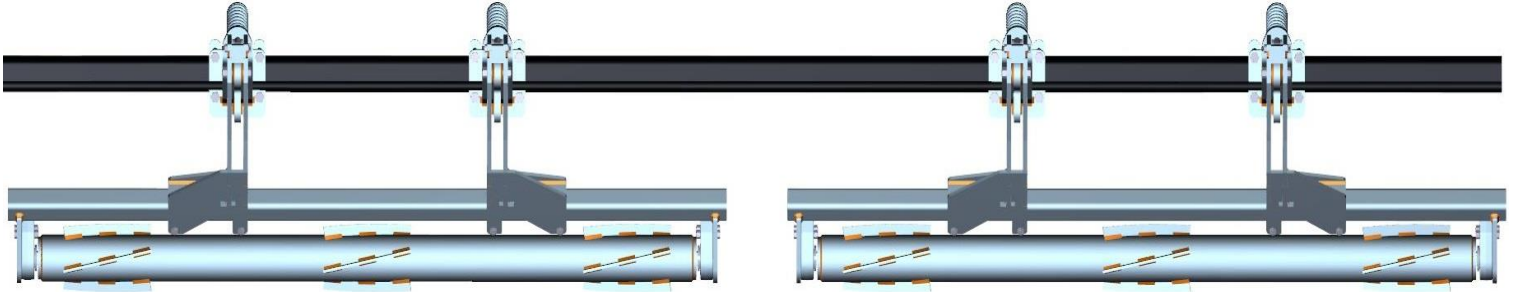

Step 1: Install each 5000-227 single mount using 2) 5000-348 mount straps, 4) 5/8" – 11 X 7" bolts, & 4) 5/8" – 11 lock nuts. Insert the 2 top mounting bolts through the 5000-228 support strap before going through the face plate of the mount. Install 1) 5/8" – 11 X 2 1/2" bolt through open end of the support strap securing to the mating hole on the mount bracket with a 5/8" whiz lock hex nut. Mount bracket locations will be between rows 1 & 2, 2 & 3, 4 & 5, and 5 & 6. Install the 5000-323 lock up pin in the storage location & secure each in place with 2) 7 gauge cotter hairpin.

NOTE: ON CERTAIN 6 ROW GERINGHOFF CORN HEADS, THE HYD. CYLINDER & SPRING ASSIST FOR THE DECK PLATE ADJUSTMENT WILL NEED MOVED. APPROXIMATELY 1FT OF HYD. HOSE WILL NEED ADDED TO REACH THE CYLINDER'S NEW LOCATION. CALL YETTER FOR MORE INFO, 1-800-447-5777, & ASK FOR SERVICE DEPARTMENT!

Step 2: Install 1) 5000-318 pivot bushing in each single mount. Attach 1) 5000-256 LH over bearing arm to the single mount between rows 2 & 3 and 5 & 6. Install 1) 5000-259 RH over bearing arm to the single mount between rows 1 & 2 and 4 & 5. Align the lower hole on each arm with the pivot bushing and insert a 5/8" X 3" bolt through & fasten with a 5/8" lock nut.

Step 3: Install 1) 2570-126 3/4" X 10" eyebolt to each single mount. Attach each over bearing arm to each eyebolt using 1) 2510-121 5/8" diameter shoulder bolt, 2) 2526-449 5/8" flat washers, & 1) 2520-364 1/2" jam lock nut. The 5/8" flat washers go on each side of the eyebolt & inside the arm channel. The shoulder bolt should be inserted through the top hole on each arm. Only tighten the 1/2" jam lock nut until it makes slight contact with the over bearing arm.

Step 4: Install the 2550-709 compression spring over each eyebolt, place the 2975-302 spring bushing over the eyebolt & onto the compression spring, & secure with the 2520-511 3/4" lock nut. Tighten the lock nut to be flush with the end of the eyebolt.

Step 5: Install each 3 row roller mount. For rows 1 – 3, slide the roller mount into place between the plates on the over bearing arm between rows 1 & 2 and 2 & 3. Use 2) 5000-378 spacer bushings, 2) 1/2" X 3 3/4" bolts, & 2) 1/2" lock nuts to attach the roller mount tube to each arm clamp. Repeat this process to attach the roller mount for rows 4 – 6 attaching the roller mount to the over bearing arms between rows 4 & 5 & 5 & 6. Do not tighten each roller mount into place until after the roller is installed so you can center the roller if needed. Make sure the bearing support is on the backside of the roller mount tab.

Step 6: Attach each roller to the roller mount using 2) 5000-322 shim washers, 2) 5000-355 bearing assemblies, 6) 1/2" X 2 1/2" bolts, & 6) 1/2" lock nuts per roller.

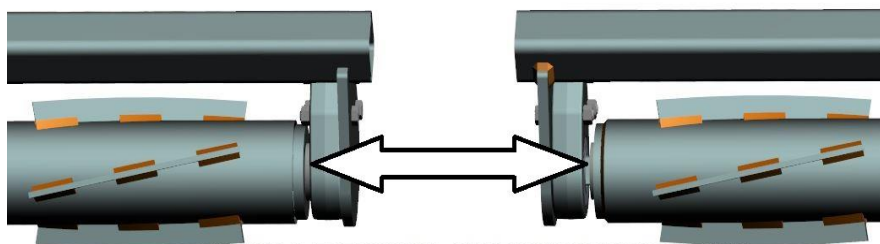

THE SIDE OF THE BEARING ASSEMBLY WHERE THE BEARING IS PROTRUDING MUST BE INSTALLED TOWARD THE ROLLER!

NOTE: BEARING HOUSING SHOULD BE LUBRICATED WITH POLYUREA GREASE BEFORE USE AND THEN EVERY 100 HOURS OF OPERATION



5000-021C ASSEMBLY INSTRUCTIONS / PART ID

GERINGHOFF 6 ROW

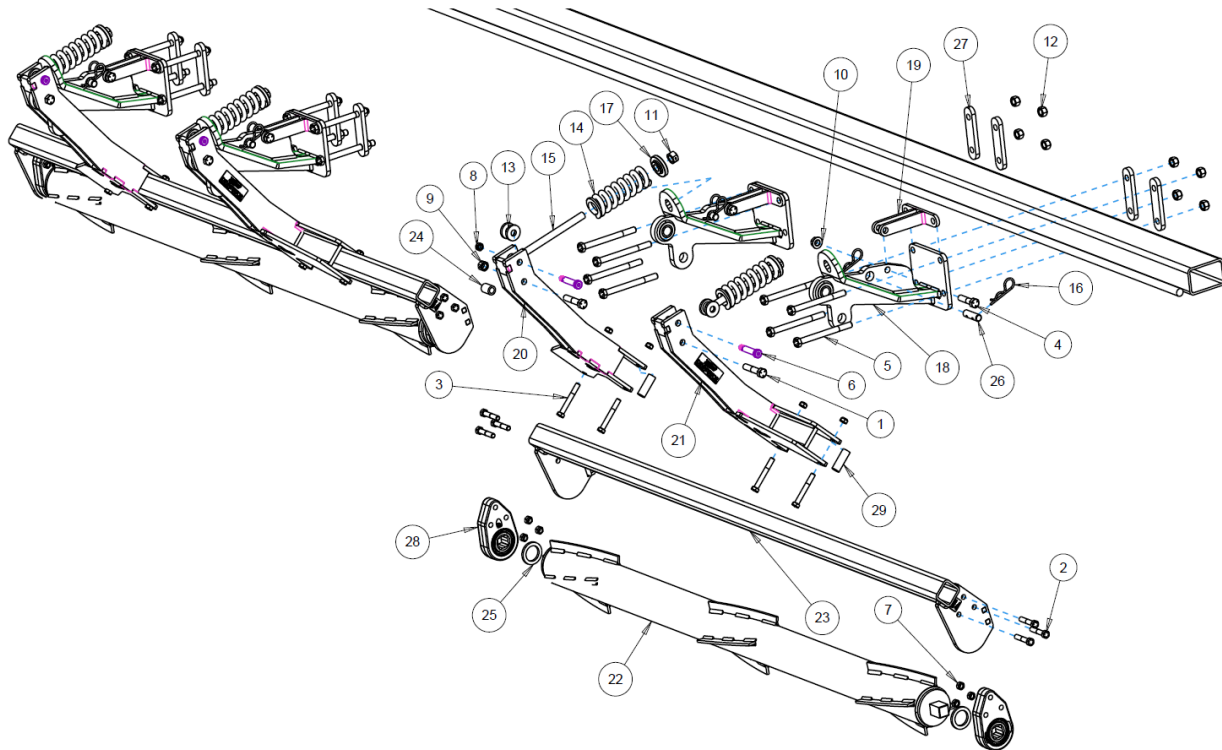

ITEM	PART #	DESCRIPTION	QTY
1	2502-325	5/8-11 X 3 CAP SCREW GRADE 5	4
2	2502-353	1/2-13 X 2.5 CAP SCREW GRADE 8	12
3	2502-365	1/2-13 X 3.75 CAP SCREW GRADE 5	8
4	2502-393	5/8-11 X 2.5 CAP SCREW GRADE 5	4
5	2502-396	5/8-11 X 7 CAP SCREW GRADE 8	16
6	2510-121	5/8 SHOULDER BOLT THREAD 1/2-13	4
7	2520-362	1/2-13 LOCK HEX NUT GRADE 8	20
8	2520-364	1/2-13 HEX JAM NUT	4
9	2520-459	5/8-11 LOCK HEX NUT GRADE 5	4
10	2520-465	5/8-11 FLANGE NUT GRADE 8	4
11	2520-515	3/4-10 LOCK HEX NUT GRADE 2	4
12	2520-603	5/8-11 TOP LOCK HEX NUT GRADE 8	16
13	2526-449	5/8 FLAT WASHER 1/4" THICK	8
14	2550-709	1/2" WIRE 2.5" OD X 1.5" ID X 7.25" LONG COMPRESSION SPRING	4
15	2570-126	3/4 X 10 EYE BOLT	4
16	2570-465	HAIRPIN	8
17	2975-302	SPRING BUSHING	4
18	5000-227	MOUNT BRACKET GERINGHOFF	4
	2528-369	SLEEVE	1/MOUNT
19	5000-228	SUPPORT STRAP GERINGHOFF	4
20	5000-256	LEFT HAND ARM 19"	2
21	5000-259	RIGHT HAND ARM 19"	2
22	5000-272	3 ROW ROLLER 71.5"	2
23	5000-275A	3 ROW ROLLER MOUNT	2
24	5000-318	PIVOT BUSHING	4
25	5000-322	SHIM WASHER	4
26	5000-323	LOCK UP PIN	4
27	5000-348	MOUNT STRAP GERINGHOFF	8
28	5000-355	BEARING ASSEMBLY	4
	2550-059	BEARING	4
29	5000-378	SPACER BUSHING	8

5000-031C ASSEMBLY INSTRUCTIONS / PART ID

FANTINI 8 ROW

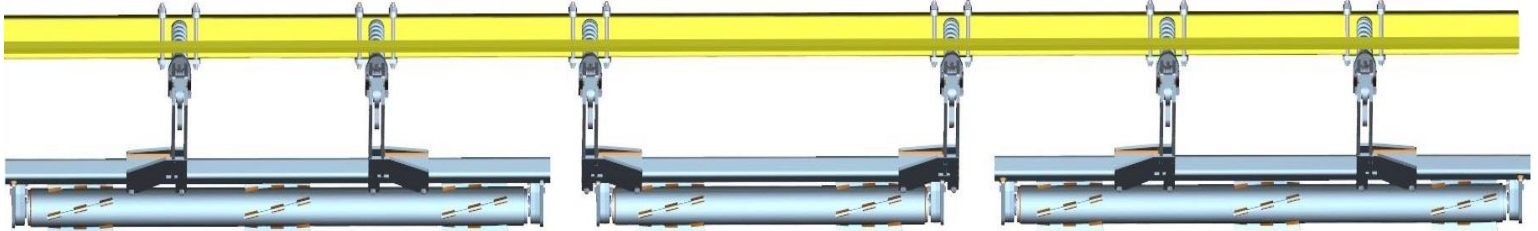

Step 1: Attach each 5000-258 mount bracket to the frame using 4) 5/8" X 7" bolts, 2) 5000-386 mount straps, 4) 5/8" flat washers (underneath mount plate), & 4) 5/8" lock hex nuts. Mounting brackets should be located between rows 1 & 2, 2 & 3, 3 & 4, 5 & 6, 6 & 7, and 7 & 8. Install the 5000-323 lock up pin in the storage location & secure each in place with 2) 7 gauge cotter hairpin.

Step 2: Install 1) 5000-318 pivot bushing in each single mount. Attach 1) 5000-256 LH over bearing arm to the single mount between rows 2 & 3, 3 & 4, and 7 & 8. Install 1) 5000-259 RH over bearing arm to the single mount between rows 1 & 2, 5 & 6, and 6 & 7. Align the lower hole on each arm with the pivot bushing & insert a 5/8" X 3" bolt through & fasten with a 5/8" lock nut.

Step 3: Install 1) 2570-126 3/4" X 10" eyebolt to each single mount. Attach each over bearing arm to each eyebolt using 1) 2510-121 5/8" diameter shoulder bolt, 2) 2526-449 5/8" flat washers, & 1) 2520-364 1/2" jam lock nut. The 5/8" flat washers go on each side of the eyebolt & inside the arm channel. The shoulder bolt should be inserted through the top hole on each arm. Only tighten the 1/2" jam lock nut until it makes slight contact with the over bearing arm.

Step 4: Install the 2550-709 compression spring over each eyebolt, place the 2975-302 spring bushing over the eyebolt & onto the compression spring, & secure with the 2520-511 3/4" lock nut. Tighten the lock nut to be flush with the end of the eyebolt.

Step 5: Install each 3 row roller mount. For rows 1 – 3, slide the roller mount into place between the clamp plates on the over bearing arm between rows 1 & 2 and 2 & 3. Repeat this process to attach the roller mount for rows 6 – 8 using the over bearing arms between rows 6 & 7 and 7 & 8. Install the 2 row roller mount by sliding the roller mount into place between the clamp plates on the arm between rows 3 & 4 and 5 & 6. The bearing mount tab will be centered in the cut-out of each clamp plate. Use 2) 5000-378 spacer bushings, 2) 1/2" X 3 3/4" bolts, & 2) 1/2" lock nuts to attach the roller mount tube to each arm clamp. Do not tighten each roller mount into place until after the roller is installed so you can center the roller if needed. Make sure the bearing support is on the back side of the roller mount tab.

Step 6: Attach each roller to the roller mount & the 5000-203B 2 row roller to the 2 row roller mount using 2) 5000-322 shim washers, 2) 5000-355 bearing assemblies, 6) 1/2" X 2 1/2" bolts, & 6) 1/2" lock nuts per roller.

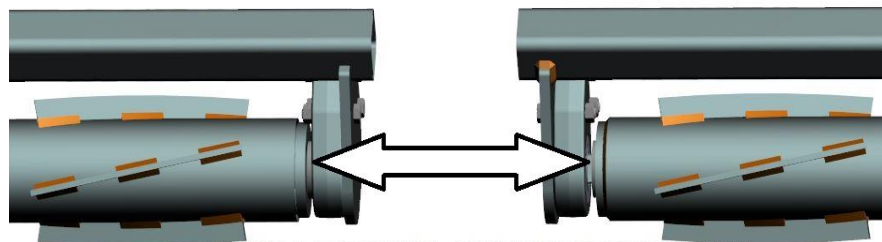

THE SIDE OF THE BEARING ASSEMBLY WHERE THE BEARING IS PROTRUDING MUST BE INSTALLED TOWARD THE ROLLER!

NOTE: BEARING HOUSING SHOULD BE LUBRICATED WITH POLYUREA GREASE BEFORE USE AND THEN EVERY 100 HOURS OF OPERATION



5000-031C ASSEMBLY INSTRUCTIONS / PART ID

FANTINI 8 ROW

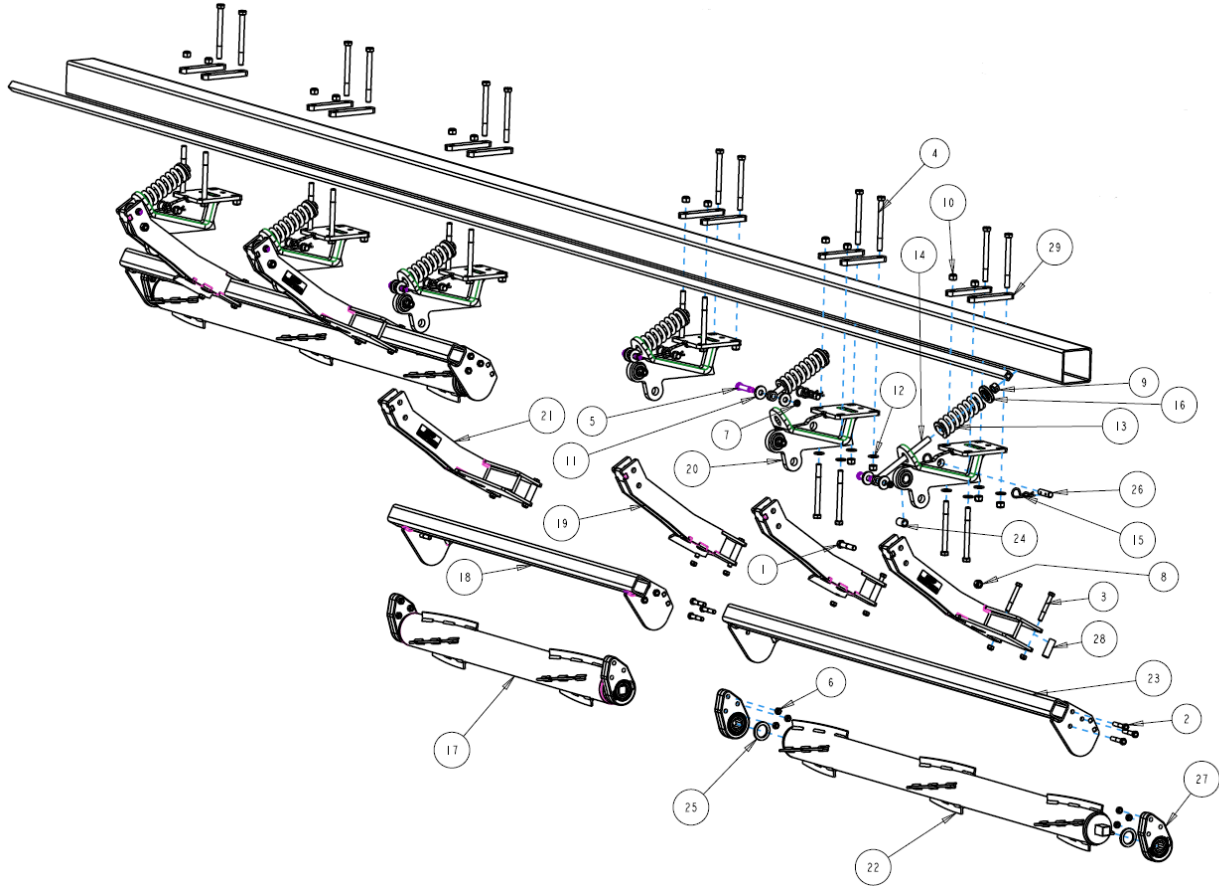

ITEM	PART #	DESCRIPTION	QTY
1	2502-325	5/8-11 X 3 CAP SCREW GRADE 5	6
2	2502-353	1/2-13 X 2.5 CAP SCREW GRADE 8	18
3	2502-365	1/2-13 X 3.75 CAP SCREW GRADE 5	12
4	2502-396	5/8-11 X 7 CAP SCREW GRADE 8	24
5	2510-121	5/8 SHOULDER BOLT THREAD 1/2-13	6
6	2520-362	1/2-13 LOCK HEX NUT GRADE 8	30
7	2520-364	1/2-13 HEX JAM NUT	6
8	2520-459	5/8-11 LOCK HEX NUT GRADE 5	6
9	2520-515	3/4-10 LOCK HEX NUT GRADE 2	6
10	2520-603	5/8-11 TOP LOCK HEX NUT GRADE 8	24
11	2526-449	5/8 FLAT WASHER 1/4" THICK	12
12	2526-453	5/8 SAE FLAT WASHER	24
13	2550-709	1/2" WIRE 2.5" OD X 1.5" ID X 7.25" LONG COMPRESSION SPRING	6
14	2570-126	3/4 X 10 EYE BOLT	6
15	2570-465	HAIRPIN	12
16	2975-302	SPRING BUSHING	6
17	5000-203B	ROLLER 48"	1
18	5000-255	ROLLER MOUNT	1
19	5000-256	LEFT HAND ARM 19"	3
20	5000-258	MOUNT BRACKET FANTINI	6
	2528-369	SLEEVE	1/MOUNT
21	5000-259	RIGHT HAND ARM 19"	3
22	5000-272	ROLLER 3 ROW 30	2
23	5000-275A	ROLLER MOUNT 3 ROW	2
24	5000-318	PIVOT BUSHING	6
25	5000-322	SHIM WASHER	6
26	5000-323	LOCK UP PIN	6
27	5000-355	BEARING ASSEMBLY	6
	2550-059	BEARING	6
28	5000-378	SPACER BUSHING	12
29	5000-386	MOUNT STRAP	12

5000-037 ASSEMBLY INSTRUCTIONS / PART ID

GERINGHOFF 8 ROW FOLDING

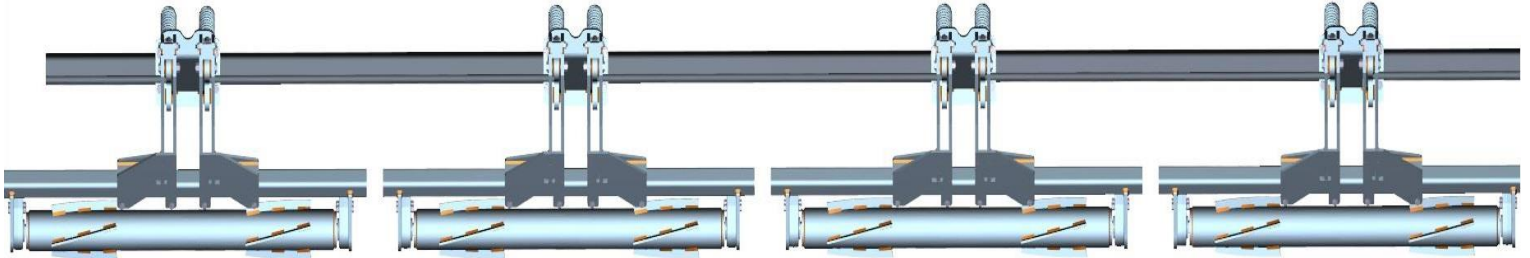

Step 1: Attach each 5000-289 double mount bracket to the frame using 4) 5/8" X 7" bolts, 2) 5000-348 mount straps, & 4) 5/8" lock hex nuts. Insert the 2 top mounting bolts through the 5000-290 support strap before going through the face plate of the mount. Install 1) 5/8" – 11 X 2" bolt through each open end of the support strap securing to the mating hole on the mount bracket with a 5/8" whiz lock hex nut. (will use 2 bolts & 2 whiz lock nuts per mount) Mounting brackets should be located between rows 1 & 2, 3 & 4, 5 & 6, and 7 & 8. Install the 5000-323 lock up pin in the storage location & secure each in place with 2) 7 gauge cotter hairpin.

NOTE: ON CERTAIN 12 ROW GERINGHOFF CORN HEADS, THE HYD. CYLINDER & SPRING ASSIST FOR THE DECK PLATE ADJUSTMENT WILL NEED MOVED. APPROXIMATELY 1FT OF HYD. HOSE WILL NEED ADDED TO REACH THE CYLINDER'S NEW LOCATION. CALL YETTER FOR MORE INFO, 1-800-447-5777, & ASK FOR SERVICE DEPARTMENT!

Step 2: Install 2) 5000-318 pivot bushing in each double mount. Attach 1) 5000-256 LH over bearing arm to the left side of each double mount. Install 1) 5000-259 RH over bearing arm to the right side of each mount. Align the lower hole on each arm with the pivot bushing and insert a 5/8" X 3" bolt through & fasten with a 5/8" lock nut.

Step 3: Install 2) 2570-126 3/4" X 10" eyebolt to each double mount. Attach each over bearing arm to each eyebolt using 1) 2510-121 5/8" diameter shoulder bolt, 2) 2526-449 5/8" flat washers, & 1) 2520-364 1/2" jam lock nut. The 5/8" flat washers go on each side of the eyebolt & inside the arm channel. The shoulder bolt should be inserted through the top hole on each arm. Only tighten the 1/2" jam lock nut until it makes slight contact with the over bearing arm.

Step 4: Install the 2550-709 compression spring over each eyebolt, place the 2975-302 spring bushing over the eyebolt & onto the compression spring, & secure with the 2520-511 3/4" lock nut. Tighten the lock nut to be flush with the end of the eyebolt.

Step 5: Install each 2 row roller mount. For rows 1 & 2, slide the roller mount into place between the plates on the over bearing arms between rows 1 & 2. Use 2) 5000-378 spacer bushings, 2) 1/2" X 3 3/4" bolts, & 2) 1/2" lock nuts to attach the roller mount tube to each arm clamp. Repeat this process to attach the roller mount for rows 3 & 4 using the over bearing arms between rows 3 & 4, rows 5 & 6 using the over bearing arms between rows 5 & 6, and 7 & 8 using the over bearing arms between rows 7 & 8. Do not tighten each roller mount into place until after the roller is installed so you can center the roller if needed. Make sure the bearing support is on the back side of the roller mount tab.

Step 6: Attach each roller to the roller mount using 2) 5000-322 shim washers, 2) 5000-355 bearing assemblies, 6) 1/2" X 2 1/2" bolts, & 6) 1/2" lock nuts per roller.

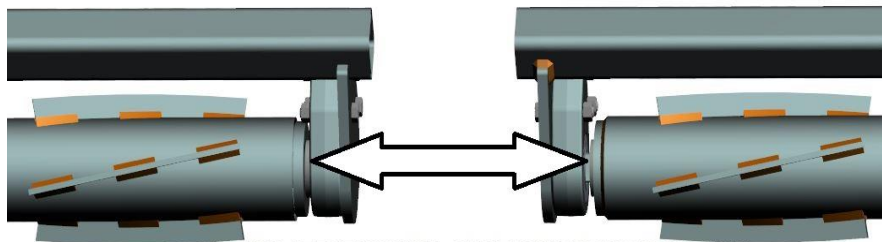

THE SIDE OF THE BEARING ASSEMBLY WHERE THE BEARING IS PROTRUDING MUST BE INSTALLED TOWARD THE ROLLER!

NOTE: BEARING HOUSING SHOULD BE LUBRICATED WITH POLYUREA GREASE BEFORE USE AND THEN EVERY 100 HOURS OF OPERATION



5000-037 ASSEMBLY INSTRUCTIONS / PART ID

GERINGHOFF 8 ROW FOLDING

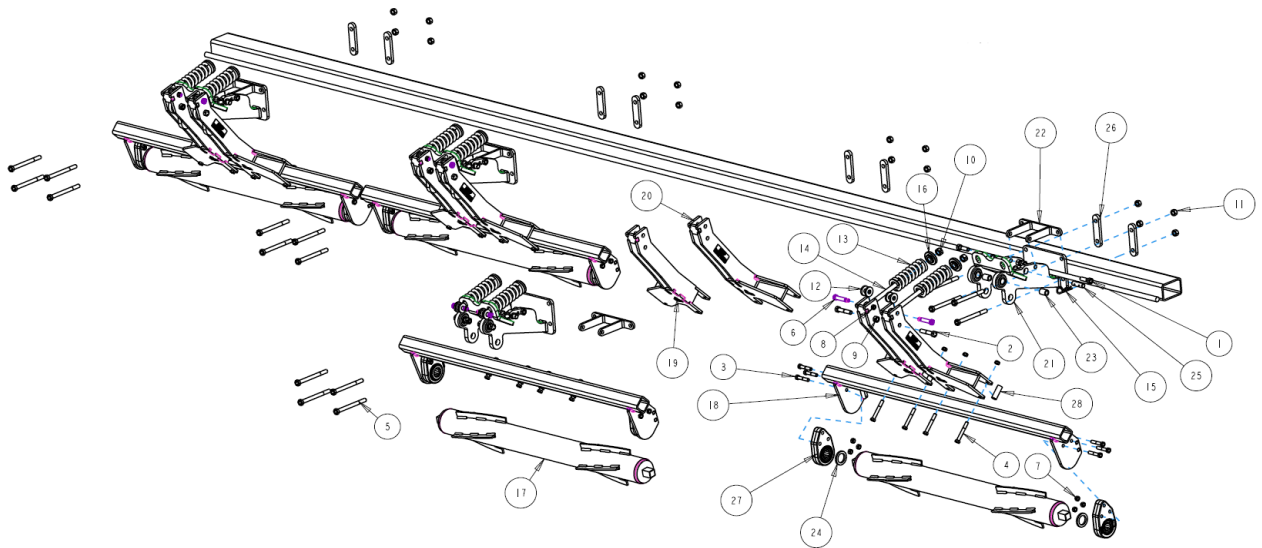

ITEM	PART #	DESCRIPTION	QTY
1	2502-322	5/8-11 X 2 CAP SCREW GRADE 8	8
2	2502-325	5/8-11 X 3 CAP SCREW GRADE 5	8
3	2502-353	1/2-13 X 2.5 CAP SCREW GRADE 8	24
4	2502-365	1/2-13 X 3.75 CAP SCREW GRADE 5	16
5	2502-396	5/8-11 X 7 CAP SCREW GRADE 8	16
6	2510-121	5/8 SHOULDER BOLT THREAD 1/2-13	8
7	2520-362	1/2-13 LOCK HEX NUT GRADE 8	40
8	2520-364	1/2-13 HEX JAM NUT	8
9	2520-459	5/8-11 LOCK HEX NUT GRADE 5	8
10	2520-515	3/4-10 LOCK HEX NUT GRADE 2	8
11	2520-603	5/8-11 TOP LOCK HEX NUT GRADE 8	24
12	2526-449	5/8 FLAT WASHER 1/4" THICK	16
13	2550-709	1/2" WIRE 2.5" OD X 1.5" ID X 7.25" LONG COMPRESSION SPRING	8
14	2570-126	3/4 X 10 EYE BOLT	8
15	2570-465	HAIRPIN	16
16	2975-302	SPRING BUSHING	8
17	5000-203B	ROLLER 48"	4
18	5000-255	ROLLER MOUNT	4
19	5000-256	LEFT HAND ARM 19"	4
20	5000-259	RIGHT HAND ARM 19"	4
21	5000-289	DOUBLE MOUNT GERINGHOFF	4
	2528-369	SLEEVE	1/MOUNT
22	5000-290	DOUBLE MOUNT SUPPORT STRAP	4
23	5000-318	PIVOT BUSHING	8
24	5000-322	SHIM WASHER	8
25	5000-323	LOCK UP PIN	8
26	5000-348	MOUNT STRAP GERINGHOFF	8
27	5000-355	BEARING ASSEMBLY	8
	2550-059	BEARING	8
28	5000-378	SPACER BUSHING	16

GERINGHOFF HYDRAULIC CYLINDER RELOCATION

ON SOME GERINGHOFF MODELS, THE HYDRAULIC CYLINDER(S) AND SPRING TENSION MECHANISM FOR THE DECK PLATE ADJUSTMENT WILL NEED RELOCATED TO ALLOW CLEARANCE FOR THE MOUNT BRACKET IN THAT LOCATION. FOLLOW THE STEPS BELOW.

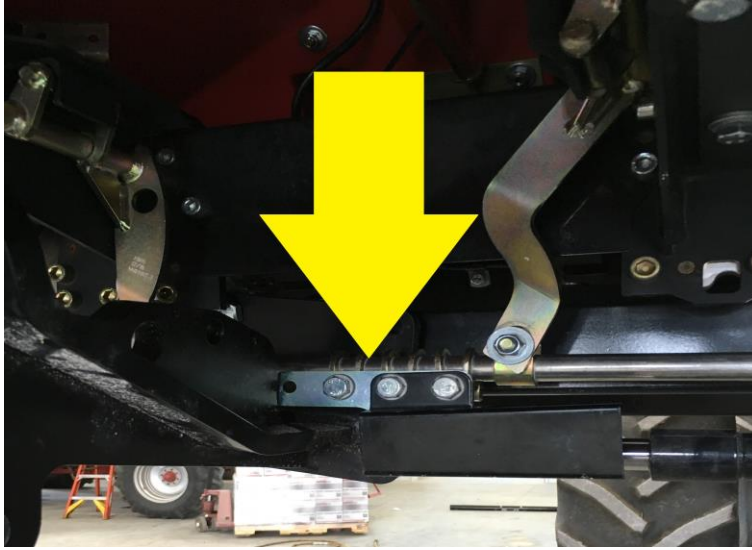

OLD LOCATION (INTERFERENCE)

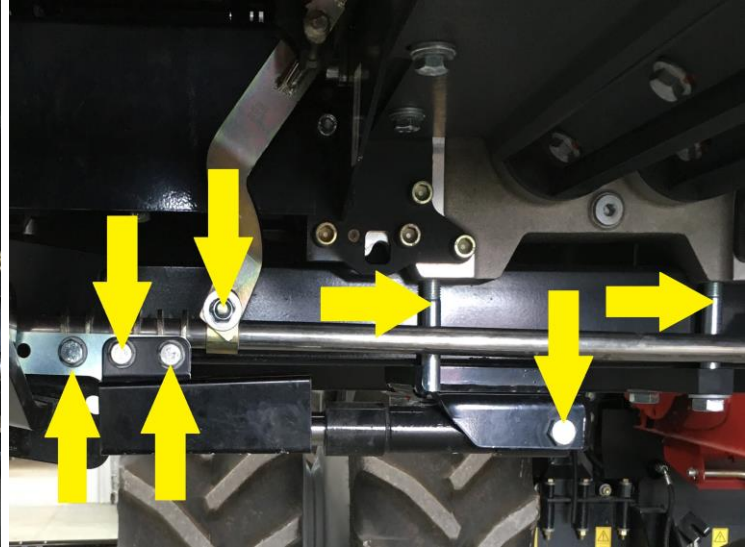

HARDWARE TO REMOVE



REPOSITIONING THE CLAMPS



NEW LOCATION REASSEMBLED

STEP 1: Remove the hardware with the yellow arrows in the photo above. Support the end of the row unit before removing the mounting straps and bolts for the gearbox (2 horizontal yellow arrows, remove both bolts for each mounting strap).

STEP 2: Reposition the hydraulic cylinder mounting bracket directly under the snapping rolls. Reposition the clamps for the cylinder on the opposite side of the swing arm. The swing arm clamp can be pried apart and removed from the adjustment rod.

STEP 3: Reassemble the hardware in the new location as originally assembly. See photo above on the right for reference.

STEP 4: Relocate the Spring Assist Mechanism, similar to the way the hydraulic cylinder procedure was accomplished, by moving the spring directly under the snapping rolls.

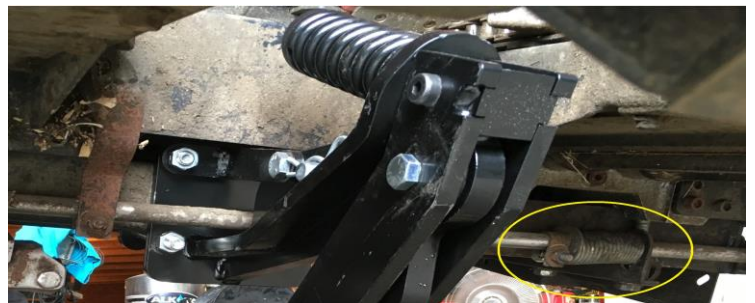

TROUBLESHOOTING

ISSUE	CAUSE	CORRECTIVE ACTION
Residue Plugging	<ol style="list-style-type: none"> 1. Incorrect Head Angle 2. Roller Mount Tube incorrectly installed 3. Pivot arm orientation incorrect 4. Bearing installed incorrectly 5. Intermeshing snapping rolls 6. Too much Spring Tension 	<ol style="list-style-type: none"> 1. Adjust head angle to 23 – 25 degrees (see page 37) 2. Make sure the Bearing Support Tab is on the backside of the Roller Arm Mount Tube 3. Reposition the pivot arm so that it offsets under the snout & not under the row 4. Make sure the side of the bearing that protrudes outside of the cast housing is facing toward the roller (each roller should spin freely by hand) 5. Order the 5000-080 Set Back Kit (order 2 per roller) 6. Back the nut off of the push rod until the nut is flush
Stalk aren't "devastated"	<ol style="list-style-type: none"> 1. Insufficient spring down pressure 2. Operating corn head too high 	<ol style="list-style-type: none"> 1. Tighten push rod nut on spring bushing more 2. Lower corn head until the rollers engage
Corn Head won't fit on head cart	<ol style="list-style-type: none"> 1. Devastators bottom out 2. Roller won't clear cart tire 3. Storage stands don't rest in the saddles on the cart 	<ol style="list-style-type: none"> 1. Adjust top rail & saddles higher on cart 2. Order 5000-082 Lift Kit (raises roller 2") 3. Raise head cart saddles & top rail, order extensions for head if offered by OEM.

NOTES



A Tradition of Solutions since 1930

Yetter Farm Equipment Co

PO BOX 358 109 S. McDonough

Colchester, IL 62326-0358

Phone: 309-776-4111

Toll Free: 800-447-5777

Email: info@yetterco.com

For updated models and manuals visit the Yetter website:

www.yetterco.com

© Yetter Farm Equipment Co. All Rights Reserved