



## **5000 SERIES STALK DEVASTATOR CORN STALK ROLLER**

**\*PATENTED\***

**5000-023C / 5000-024C / 5000-035A / 5000-039  
AGCO/Gleaner 3000, 3308 & 3312 Hugger 630/830,  
MF 3000 (1988 & Newer), Challenger CH630 & CH830**

**OPERATOR'S MANUAL  
PART IDENTIFICATION  
2565-784\_REV\_E – 01/2024**



**YETTER MANUFACTURING CO.**  
*FOUNDED 1930*

Colchester, IL 62326-0358  
Toll free: 800/447-5777  
309/776-3222 (Fax)  
Website: [www.yetterco.com](http://www.yetterco.com)  
E-mail: [info@yetterco.com](mailto:info@yetterco.com)

**YETTER**

# DEVASTATOR OPERATION CHECKLIST

Please fill this out after the Yetter Stalk Devastator has been installed.

DATE \_\_\_/\_\_\_/\_\_\_ YETTER KIT # - 5000-\_\_\_ CORN HEAD MAKE/MODEL\_\_\_\_\_

COMBINE MAKE/MODEL\_\_\_\_\_ FRONT TIRE SIZE\_\_\_\_\_ REAR TIRE SIZE\_\_\_\_\_

REAR AXLE POSITION\_\_\_\_\_ SNAPPING ROLLS USING\_\_\_\_\_ CHOPPING BLADES YES / NO

DECK PLATE ANGLE\_\_\_\_\_° (USE ANGLE FINDER) SNAPPING ROLL HEIGHT (OPERATING POSITION)\_\_\_\_\_INCHES

HARVEST SPEED\_\_\_\_\_MPH HEAD SPEED\_\_\_\_\_ ANGLE TORSION ARM (OPERATING POSITION - USE ANGLE FINDER)\_\_\_\_\_

HEAD CART INFO:

MAKE/MODEL\_\_\_\_\_ LENGTH\_\_\_\_\_ TIRE SIZE\_\_\_\_\_

## FOREWORD

You've just joined an exclusive but rapidly growing club.

For our part, we want to welcome you to the group and thank you for buying a Yetter product.

We hope your new Yetter products will help you achieve both goals-increase your productivity and increase your efficiency so that you may generate more profit.

This operator's manual has been designed into four major sections: Foreword, Safety Precautions, Installation Instructions and Parts Breakdown.

This **SAFETY ALERT SYMBOL** indicates important safety messages in the manual. When you see this symbol, be alert to the possibility of **PERSONAL INJURY** and carefully read the message that follows.



The word **NOTE** is used to convey information that is out of context with the manual text. It contains special information such as specifications, techniques and reference information of a supplementary nature.

The word **IMPORTANT** is used in the text when immediate damage will occur to the machine due to improper technique or operation. Important will

apply to the same information as specified by note only of an immediate and urgent nature.

It is the responsibility of the user to read the operator's manual and comply with the safe and correct operating procedure and to lubricate and maintain the product according to the maintenance schedule in the operator's manual.

The user is responsible for inspecting his machine and for having parts repaired or replaced when continued use of the product would cause damage or excessive wear to the other parts.

It is the user's responsibility to deliver his machine to the Yetter dealer who sold him the product for service or replacement of defective parts, which are covered by the warranty policy.

If you are unable to understand or follow the instructions provided in this publication, consult your local Yetter dealer or contact:

### YETTER MANUFACTURING CO.

309/776-4111

800/447-5777

309/776-3222 (FAX)

Website: [www.yetterco.com](http://www.yetterco.com)

E-mail: [info@yetterco.com](mailto:info@yetterco.com)

## WARRANTY

Yetter Manufacturing warrants all products manufactured and sold by it against defects in material. This warranty being expressly limited to replacement at the factory of such parts or products as shall appear to be defective after inspection. This warranty does not obligate the Company to bear cost of labor in replacement of parts. It is the policy of the Company to make improvements without incurring obligations to add them to any unit already sold. No warranty is made or authorized to be made, other than herein set forth. This warranty is in effect for one year after purchase.

DEALER: \_\_\_\_\_

Yetter Manufacturing warrants its own products only & cannot be responsible for damages to equipment on which mounted.

# **BE ALERT!**

## **YOUR SAFETY IS INVOLVED.**



**WATCH FOR THIS SYMBOL. IT POINTS OUT IMPORTANT SAFETY PRECAUTIONS. IT MEANS “ATTENTION---BECOME ALERT!”**

It is your responsibility as an owner, operator, or supervisor to know and instruct everyone using this machine at the time of initial assignment and at least annually thereafter, of the proper operation, precautions, and work hazards which exist in the operation of the machine in accordance with OSHA regulations.

## **Safety Is No Accident**

**The following safety instructions, combined with common sense, will save your equipment from needless damage and the operator from unnecessary exposure to personal hazard. Pay special attention to the caution notes in the text. Review this manual at least once each year with new and/or experienced operators.**



1. Read and understand the operator's manual before operating this machine. Failure to do so is considered a misuse of the equipment.
2. Make sure equipment is secure before operating.
3. Always keep children away from equipment when operating.
4. Make sure everyone that is not directly involved with the operation is out of the work area before beginning the operation.
5. Make sure all safety devices, shields, and guards are in place and are functional before beginning the operation.
6. Shut off power to adjust, service, or clean.
7. Keep hands, feet, and clothing away from moving parts. It is a good idea to remove all jewelry before starting the operation.
8. Visually inspect the machine periodically during operation for signs of excessive vibration, loose fasteners, and unusual noises.

# PLEASE READ, VERY IMPORTANT



**SECURE THE CORN HEADER AGAINST UNWANTED LOWERING BY APPLYING THE LOCKING MECHANISM ON HYDRAULIC CYLINDERS!**



1. Attach head to combine, lock head to combine
2. Raise the head off the ground and engage safety stop on the feeder house cylinder
3. Turn off the combine engine and remove the key

**FOLLOW ALL INSTRUCTIONS GIVEN BY THE COMBINE MANUFACTURER**

Subject to the size and weight of the corn header, one or two additional hydraulic cylinders may be required.

The combine manufacturer generally keeps corresponding kits readily available for dealers.

Subject to the design of the corn header & the carry capacity of different combines, the steering axel may require the fitting of additional weights & the rear tires be filled with ballast.

**FOLLOW ALL INSTRUCTIONS GIVEN BY THE COMBINE MANUFACTURER**

# TABLE OF CONTENTS

OPERATION CHECKLIST / FORWARD / WARRANTY.....	2
SAFETY INFORMATION.....	3 - 4
TABLE OF CONTENTS.....	5
TORQUE / TOOLS REQUIRED.....	5
<b>ASSEMBLY INSTRUCTIONS</b>	
5000-023C & 5000-024C .....	6 - 9
5000-035A.....	10 - 13
5000-039.....	14 - 17
OPERATION / STORAGE / .....	18
BEARING REPLACEMENT / LOCKUP / TROUBLESHOOTING..	19
<b>PARTS IDENTIFICATON</b>	
5000-023C.....	20 - 21
5000-024C.....	22 - 23
5000-035A.....	24 - 25
5000-039.....	26 - 27



## BOLT TORQUE



**Important:** Over-tightening hardware can cause just as much damage as under-tightening. Tightening hardware beyond the recommended range can reduce its shock load capacity.

All hardware on the 5000 Devastator is either Grade 5 or Grade 8, unless otherwise noted. Grade 5 cap screws are marked with three radial lines on the head. Grade 8 cap screws are marked with six radial lines on the head. If hardware must be replaced, be sure to replace it with hardware of equal size, strength & thread type. Refer to the torque values chart when tightening hardware.

The chart below is a guide for proper torque. Use it unless a specified torque is called out elsewhere in the manual. Torque is the force applied to the end of the handle or cheater bar, times the length of the handle or bar.

### Use a torque wrench wherever possible

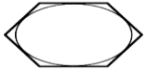
The following table shows torque in ft.-lbs. for coarse thread hardware.

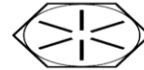
Bolt Diameter and Threads per Inch	 Grade 2	 Grade 5	 A-325	 Grade 8
1/4	6	10	10	14
5/16	12	20	20	30
3/8 - 16	25	35	35	50
7/16 - 14	35	55	55	80
1/2 - 13	55	85	85	125
9/16 - 12	75	125	125	175
5/8 - 11	105	170	170	235
3/4-10	185	305	305	425
7/8 - 9	170	445	445	690
1-8	260	670	670	1030
1 1/8 - 7	365	900	900	1460
1 1/4 - 7	515	1275	1275	2060
1 3/8 - 6	675	1675	1675	2700
1 1/2 - 6	900	2150	2150	3500
1 3/4 - 5	1410	3500	3500	5600

### INSTALLATION TOOLS REQUIRED:

- Pneumatic or electric impact driver
- 3/4 & 15/16 size sockets
- 10" impact driver extension
- Ratchet
- 3/4, 15/16, & 1 1/8 size wrenches
- 5/16 Allen Wrench
- Torque Wrench





# 5000-023C & 5000-024C ASSEMBLY INSTRUCTION

## GLENER 3000 / HUGGER 630 & 830 / MF 3000 / CHALLENGER CH630 & CH 830

**STEP 1.** Attach the 5000-248 Extension Mount to the 5000-247 Plate using 5/8" X 2" Bolts & 5/8" Lock Hex Nuts.

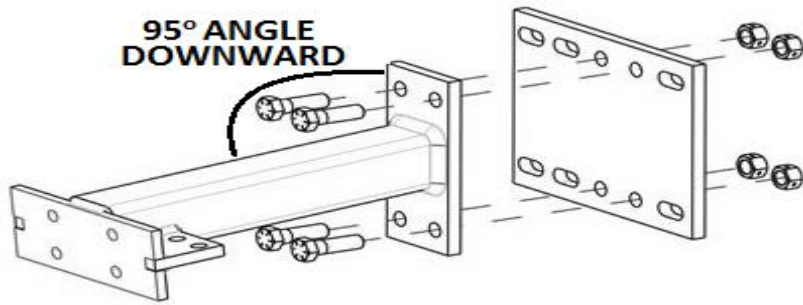

**STEP 2.** Install Mount Assembly to Corn Head Frame using 5/8" X 8" Bolts, Clamp Plates, 5/8" Washers, & 5/8" Lock Hex Nuts. When mounting the assembly to head frame, the extension mount will angle downward.

**NOTE:** Do not fully tighten hardware until the pivot arms are installed during Step 6.

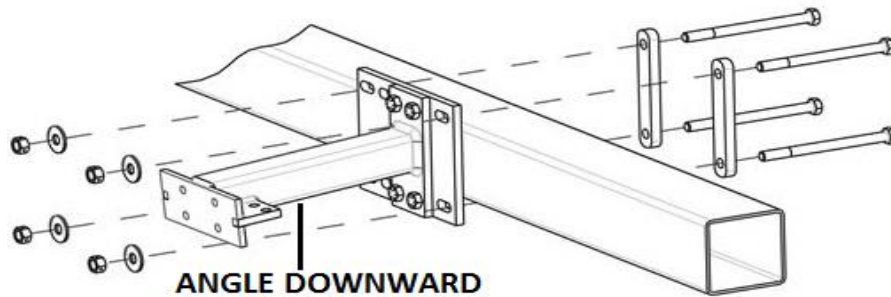

### 5000-023C 6 ROW MOUNTING LOCATIONS

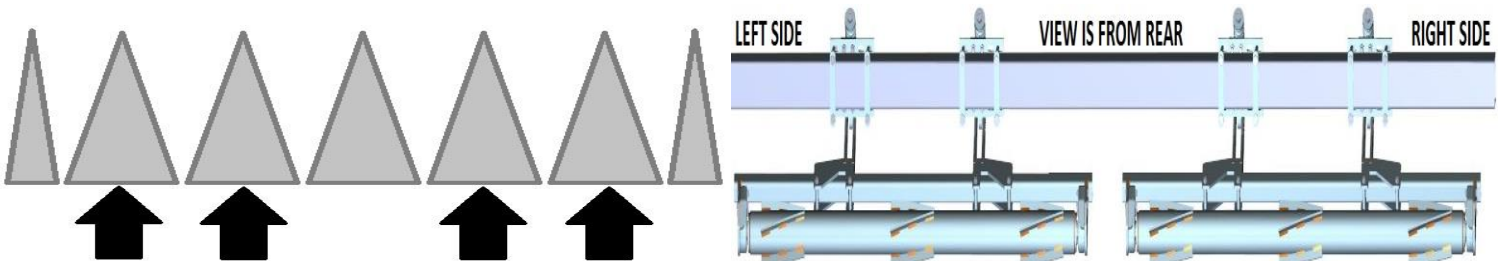

### 5000-024C 8 ROW MOUNTING LOCATIONS

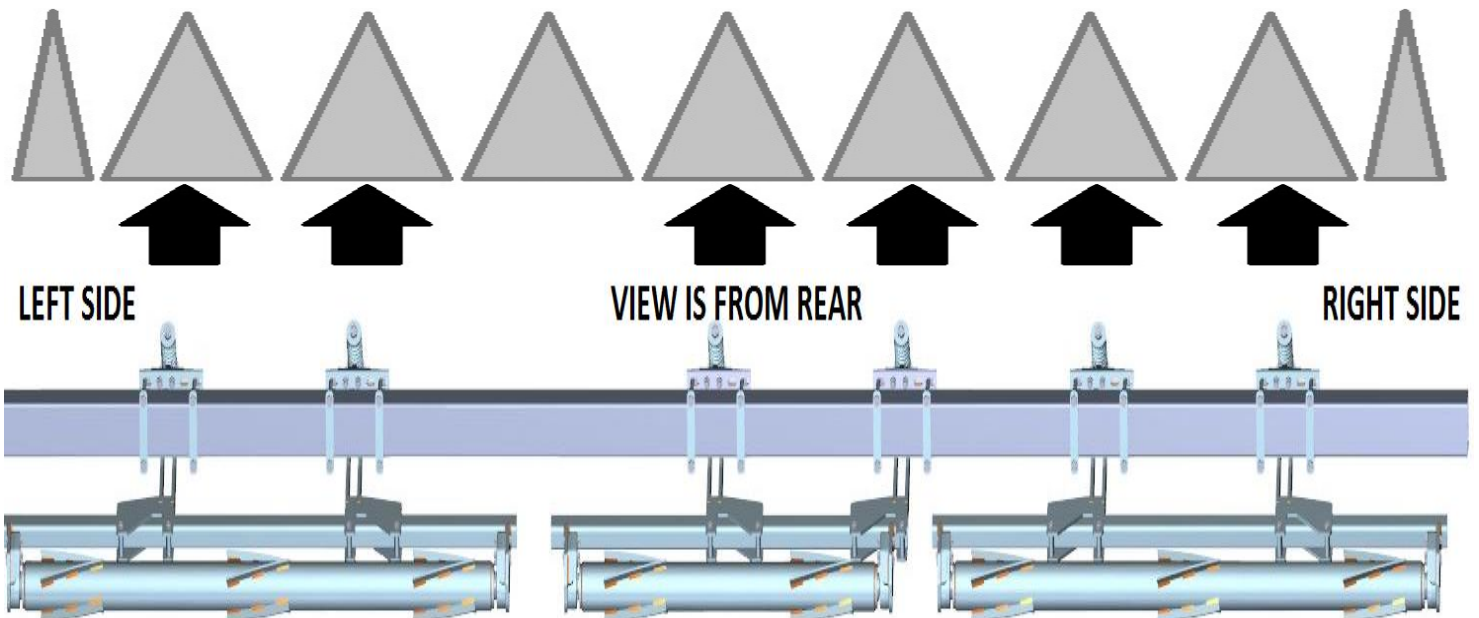

# 5000-023C & 5000-024C ASSEMBLY INSTRUCTION

**STEP 3:** Attach the 5000-135 Arm Mounts to the Extension Mount Bracket using 1/2" X 2" Bolts, 1/2" Washers, & 1/2" Lock Hex Nuts.

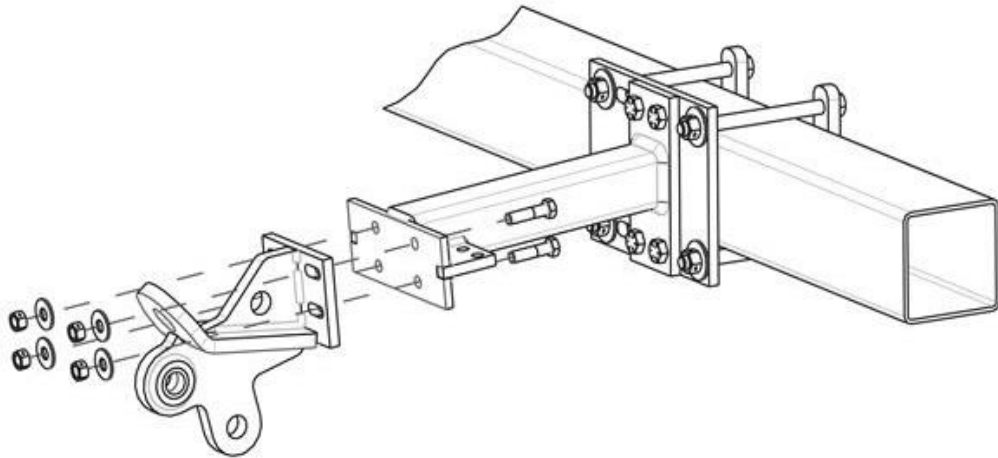

**STEP 4:** Install the 5000-323 Lock Up Pin in the storage location on the mount arms, secure with Hair Pin Clips.

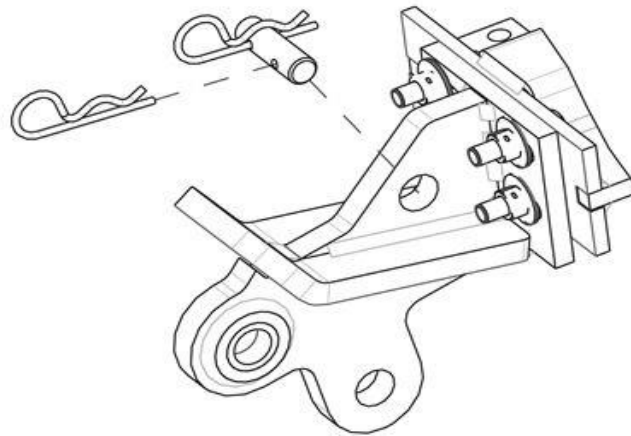

**STEP 5:** Attach each 5000-256 & 5000-259 Overbearing Arm to the Mount Brackets using 5/8" X 3" Bolts, Pivot Bushing, & 5/8" Lock Hex Nuts using the upper hole on the arms. Fully tighten all the hardware.

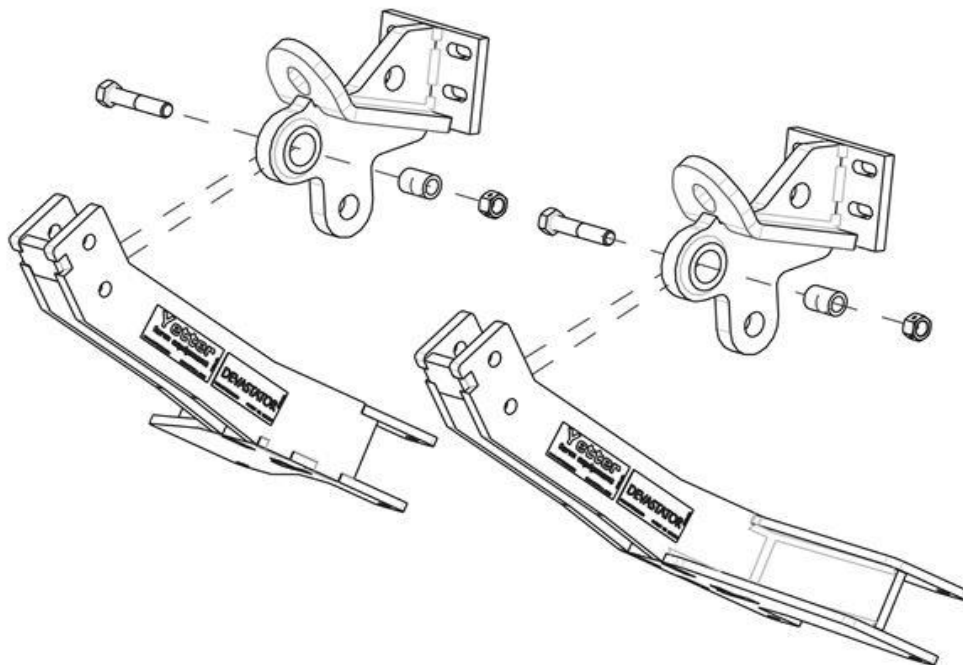

# 5000-023C & 5000-024C ASSEMBLY INSTRUCTION

**STEP 6:** Install the push rods into the mount brackets & attach to the pivot arms using the 5/8" Shoulder Bolts, 5/8" Washers, & 1/2" Jam Nuts. Use the lower hole on the arm. The washers are to be installed on each side of the "Eye" on the push Rod. Now install the Compression Springs, Spring Bushings, & 3/4" Lock Hex Nut.

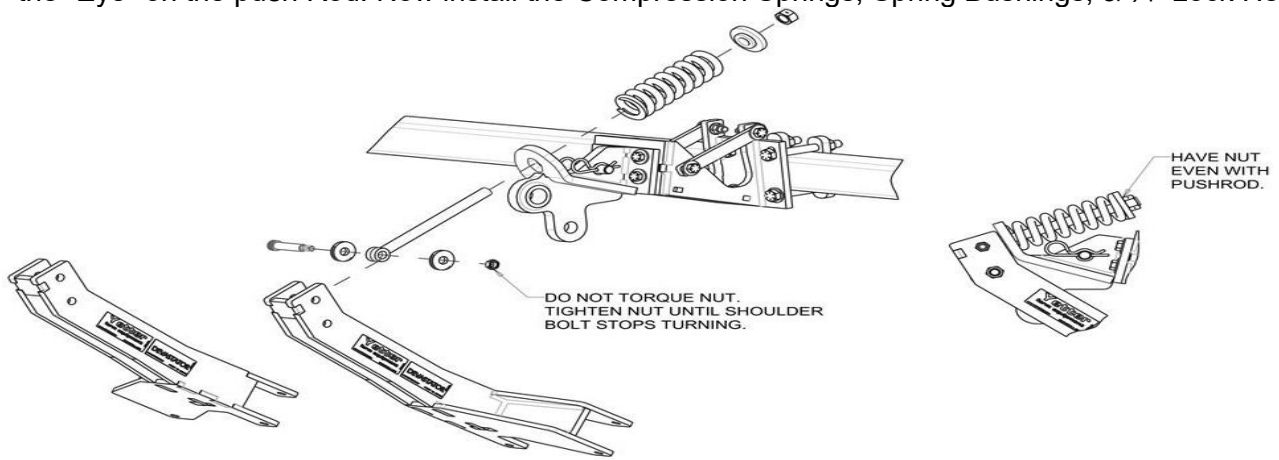

**STEP 7:** Attach the roller mounts to the over bearing arms, & then install the 1/2" X 3 3/4" Bolts, Spacers, & 1/2" Lock Nuts. Slide the roller mount tubes side to side as needed to clear the end of the corn head.

**NOTE:** Make sure the Bearing Support Tab is on the backside of the Bearing Mounting Plate.

## 2 ROW ROLLER ASSEMBLY

## 3 ROW ROLLER ASSEMBLY

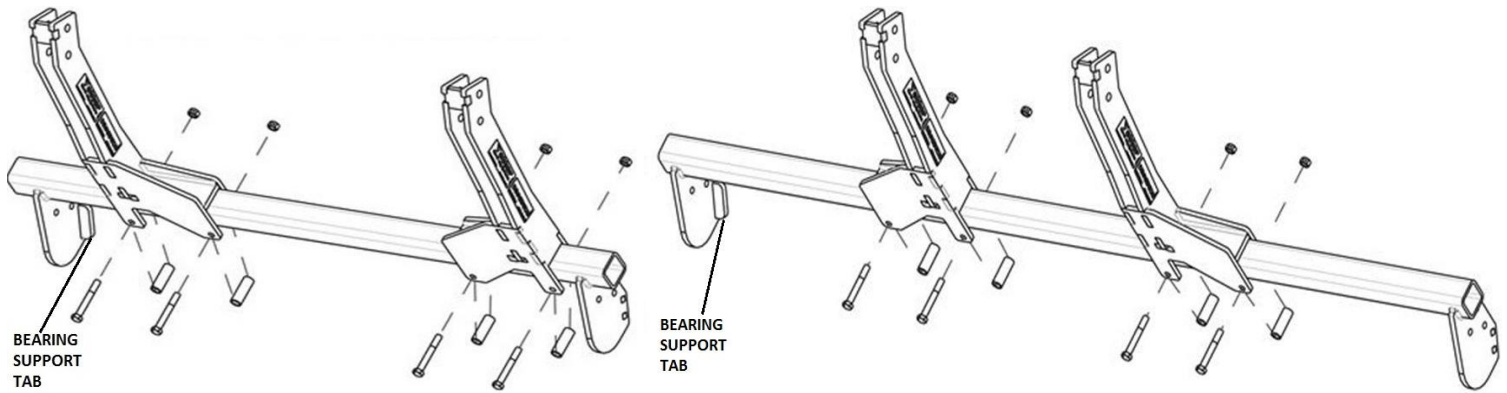



# 5000-023C & 5000-024C ASSEMBLY INSTRUCTION

**Step 8:** Insert the shim washer over the shaft on each end of the roller. Install the bearing over the shaft on each end of the roller so that the side of the casting that has the bearing protruding past the housing surface is towards the roller barrel & shim washer. Lift each roller into place, install the 1/2" X 2 1/2" bolts & tighten the 1/2" lock nuts. Once the roller & bearing hardware is fastened, spin the roller to ensure the bearing was installed correctly. If the roller was installed incorrectly, the roller will not spin or will have drag. Slide the roller mount tube to gain clearance on each end of the corn head & then tighten the hardware.

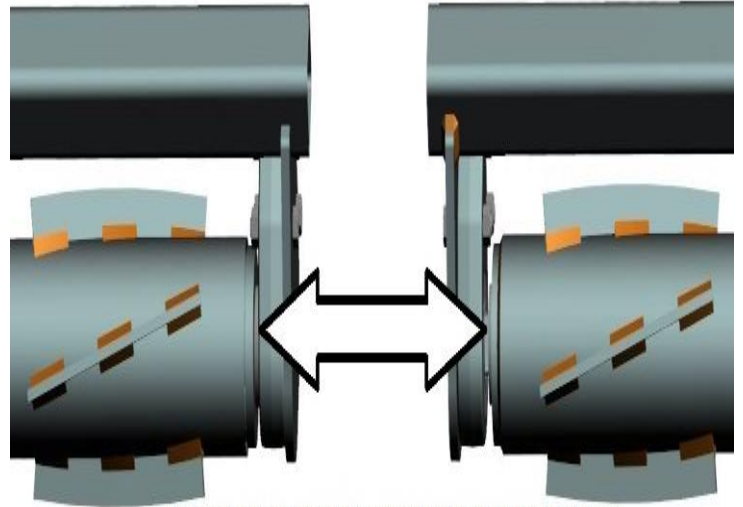
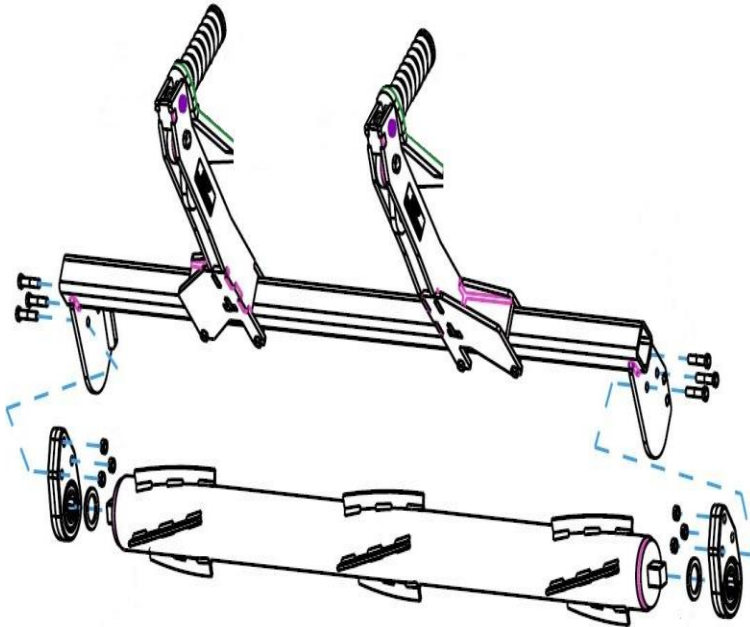

THE SIDE OF THE BEARING ASSEMBLY WHERE THE BEARING IS PROTRUDING MUST BE INSTALLED TOWARD THE ROLLER!

**NOTE: BEARING HOUSING SHOULD BE LUBRICATED WITH POLYUREA GREASE BEFORE USE AND THEN EVERY 100 HOURS OF OPERATION**



# 5000-035A ASSEMBLY INSTRUCTION

## AGCO GLEANER 3308

**STEP 1:** Install the Mount Assemblies on the Corn Head Frame using 5/8" X 7" Bolts, Mount Straps, Clamp Brackets/Straps, 5/8" Washers, & 5/8" Lock Hex Nut. Place Mounts, Mount Straps, & Brackets as shown. The Double Mount goes between rows 4 & 5.

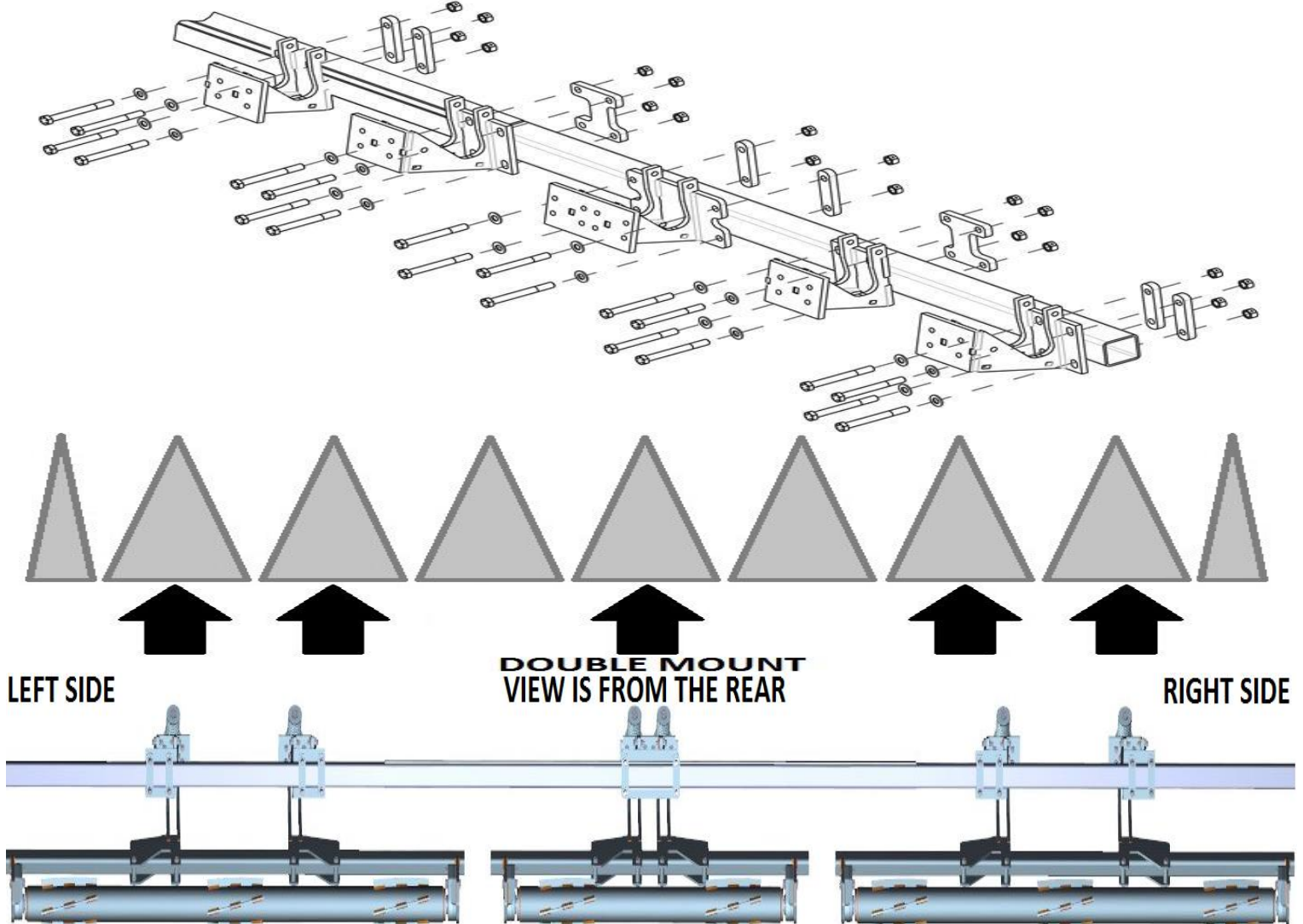

**STEP 2:** Attach the 5000-309 Support Straps to the 5000-246, 5000-251, & 5000-252 Offset Mounts using the 1/2" X 1 3/4" Bolts & 1/2" Flange Lock Hex Nuts.

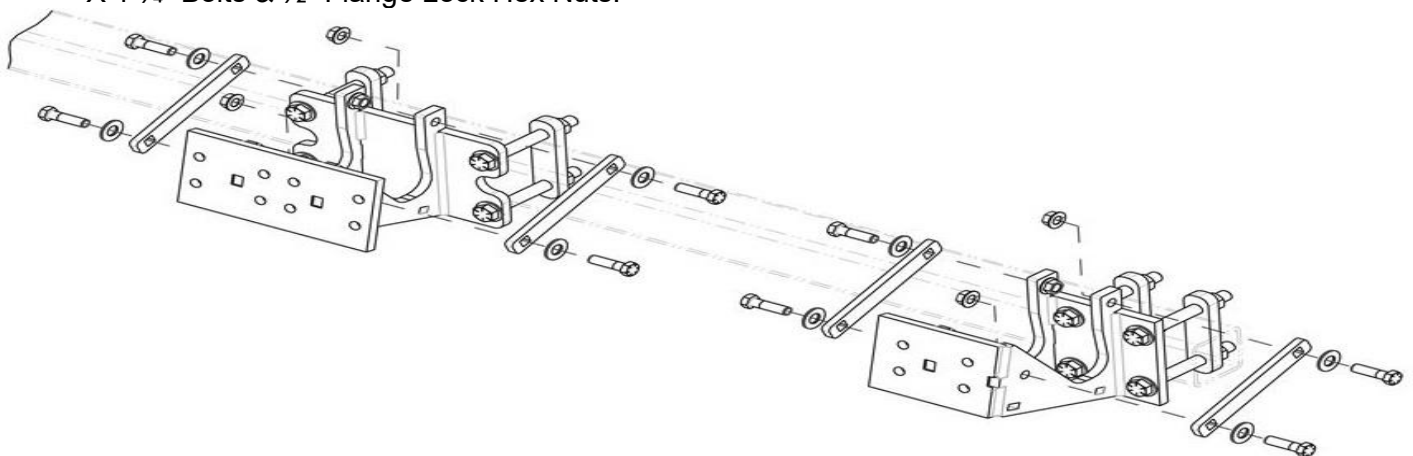

# 5000-035A ASSEMBLY INSTRUCTION

**STEP 3:** Attach 1) 5000-135 Arm Mount on each Offset Mount using  $\frac{1}{2}$ " X  $1\frac{3}{4}$ " Bolts,  $\frac{1}{2}$ " Washers, &  $\frac{1}{2}$ " Lock Hex Nuts. Attach 2 Arm Mounts to the Double Offset on rows 4 & 5.

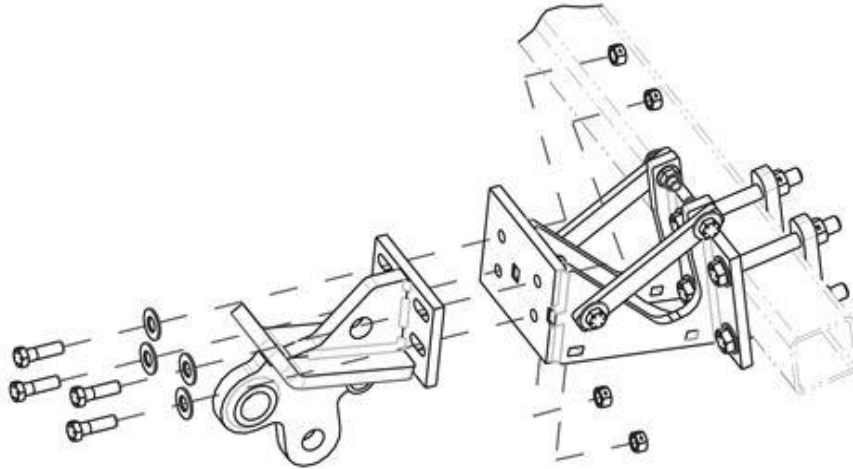

**STEP 4:** Install a 5000-323 Lock Up Pin in the storage location on the Mount Arms & secure with Hair Pin Clips.

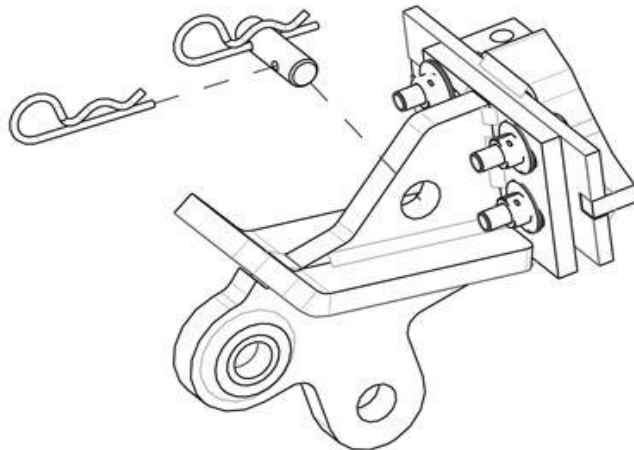

**STEP 5:** Attach the 5000-256 & 5000-259 Overbearing Arms to the Mount Brackets using  $\frac{5}{8}$ " X 3" Bolts, Pivot Bushings, &  $\frac{5}{8}$ " Lock Hex Nuts using the upper hole on the arms. Fully tighten all hardware at this time.

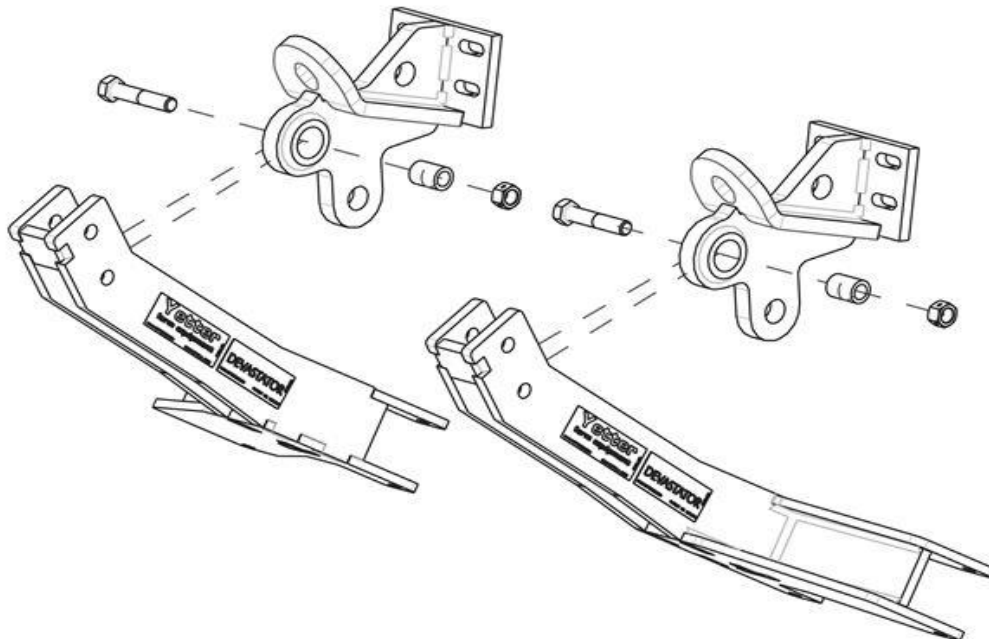

# 5000-035A ASSEMBLY INSTRUCTION

**STEP 6:** Install each Push Rods into the Mount Bracket & attach to the Pivot Arms using 5/8" Shoulder Bolts, 5/8" Washers, & 1/2" Jam Lock Hex Nuts. Use the lower hole on the arm. The washers are to be installed on each side of the "EYE" on the Push Rod. Now install the Compression Springs, Spring Bushings, & 3/4" Lock Hex Nuts.

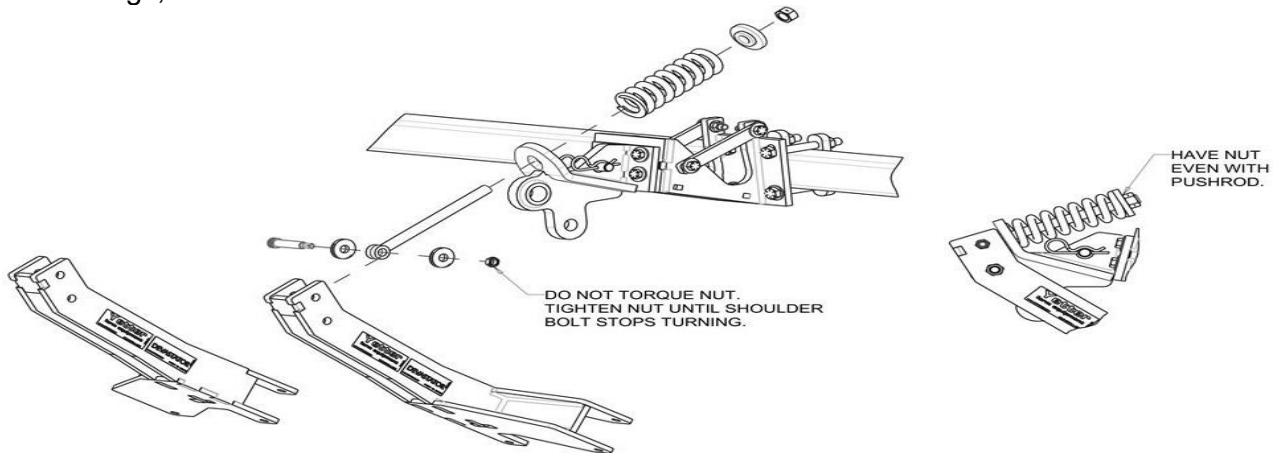

**STEP 7:** Attach the Roller Mounts to the Overbearing Arms, & then install the 1/2" X 3 3/4" Bolts, Spacers, & 1/2" Lock hex Nuts. Slide the Roller Mount Tubes side to side as needed to clear the end of the Corn Head.

**NOTE:** Make sure the Bearing Support Tab in on the backside of the Bearing Mounting Plate.

## 2 ROW ROLLER ASSEMBLY

## 3 ROW ROLLER ASSEMBLY

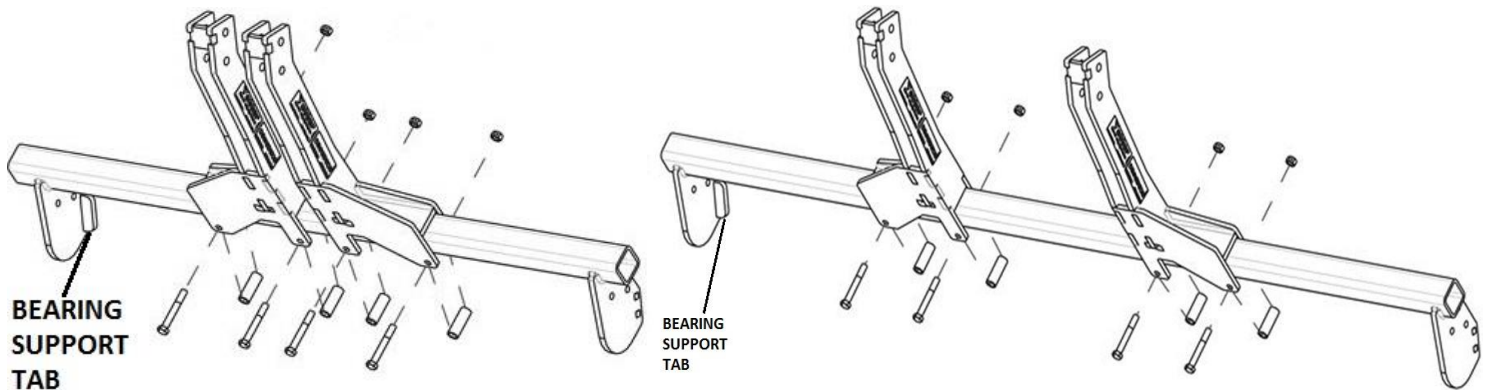

# 5000-035A ASSEMBLY INSTRUCTION

**Step 8:** Insert the shim washer over the shaft on each end of the roller. Install the bearing over the shaft on each end of the roller so that the side of the casting that has the bearing protruding past the housing surface is towards the roller barrel & shim washer. Lift each roller into place, install the 1/2" X 2 1/2" bolts & tighten the 1/2" lock nuts. Once the roller & bearing hardware is fastened, spin the roller to ensure the bearing was installed correctly. If the roller was installed incorrectly, the roller will not spin or will have drag. Slide the roller mount tube to gain clearance on each end of the corn head & then tighten the hardware.

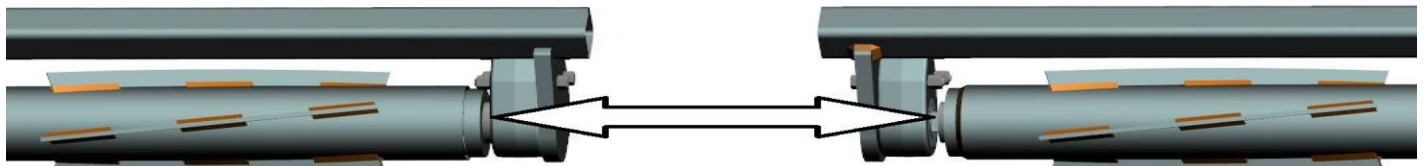
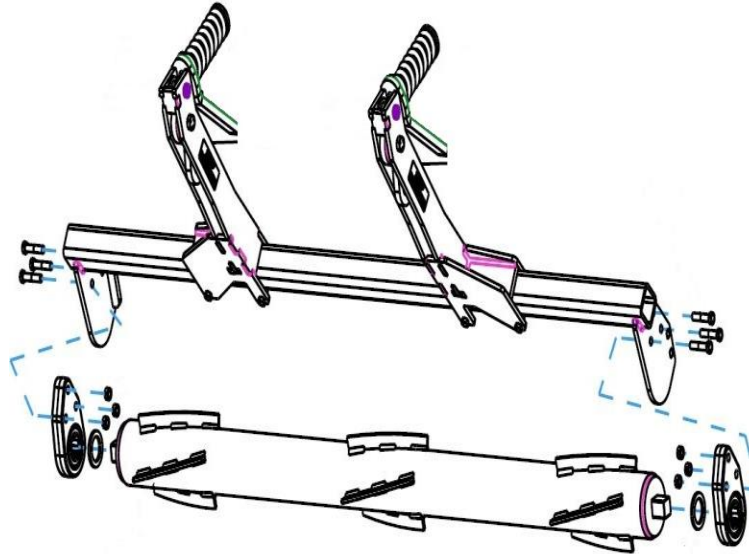

THE SIDE OF THE BEARING ASSEMBLY WHERE THE BEARING IS PROTRUDING MUST BE INSTALLED TOWARD THE ROLLER!

NOTE: BEARING HOUSING SHOULD BE LUBRICATED WITH POLYUREA GREASE BEFORE USE AND THEN EVERY 100 HOURS OF OPERATION





# 5000-039 ASSEMBLY INSTRUCTION

## AGCO GLEANER 3312

**STEP 1:** Install the Mount Assemblies on the Corn Head Frame using 5/8" X 7" Bolts, Mount Straps, Clamp Brackets/Straps, 5/8" Washers, & 5/8" Lock Hex Nut. Place Mounts, Mount Straps, & Brackets as shown. The 5000-246 Double Mount brackets will be installed between rows 3-4, 6-7, 9-10.

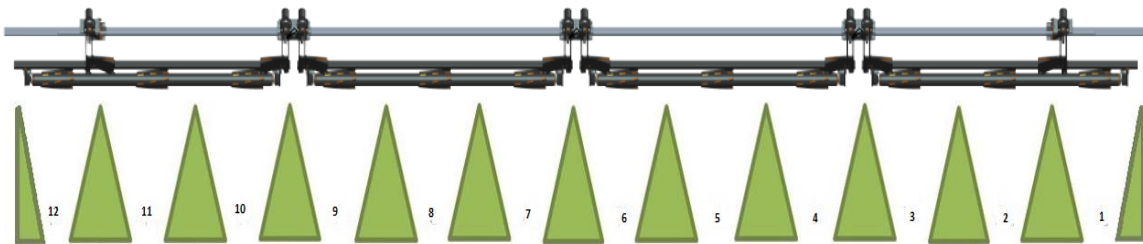
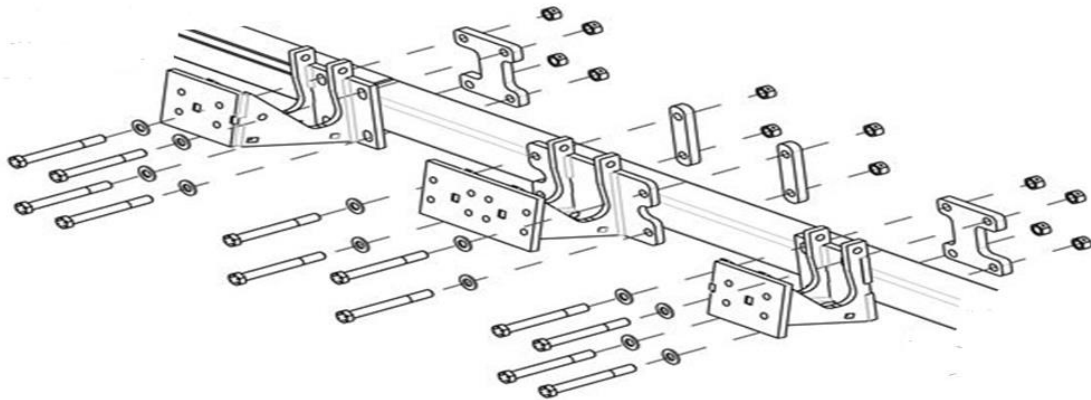

**FRONT VIEW ROWS: 12 11 10 9 8 7 6 5 4 3 2 1**

# 5000-039 ASSEMBLY INSTRUCTION

## AGCO GLEANER 3312

**STEP 2:** Attach the 5000-309 Support Straps to the 5000-246, 5000-251, & 5000-252 Offset Mounts using the  $\frac{1}{2}$ " X  $1\frac{3}{4}$ " Bolts &  $\frac{1}{2}$ " Flange Lock Hex Nuts.

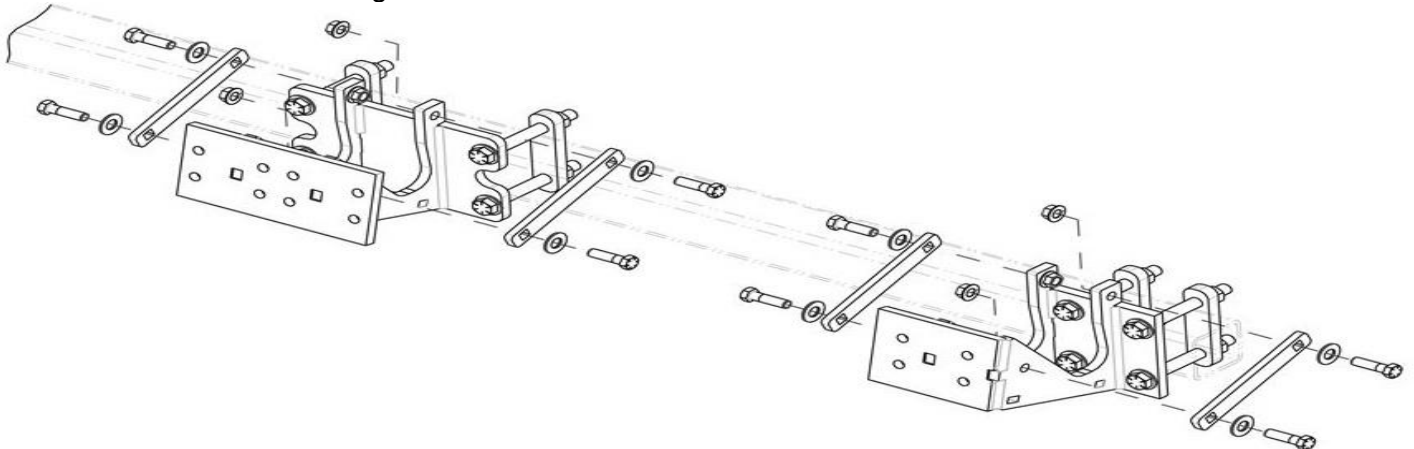

**STEP 3:** Attach 1) 5000-135 Arm Mount on each Offset Mount using  $\frac{1}{2}$ " X  $1\frac{3}{4}$ " Bolts,  $\frac{1}{2}$ " Washers, &  $\frac{1}{2}$ " Lock Hex Nuts. Attach 2 Arm Mounts to the Double Offset Mounts.

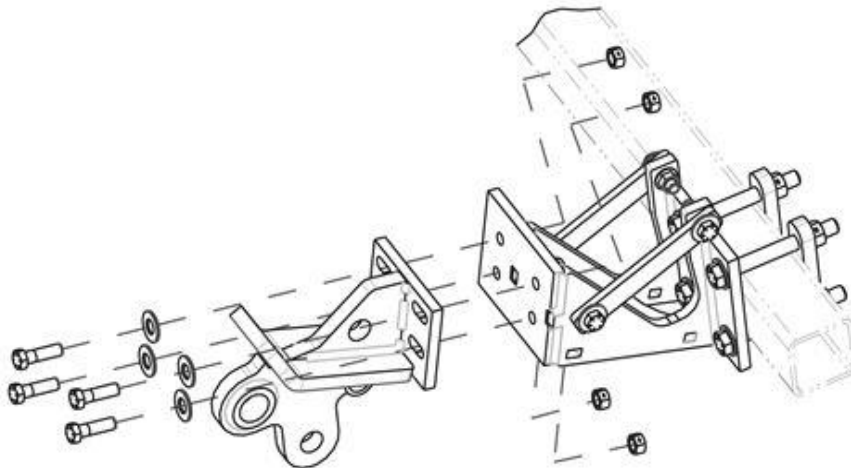

**STEP 4:** Install a 5000-323 Lock Up Pin in the storage location on the Mount Arms & secure with Hair Pin Clips.

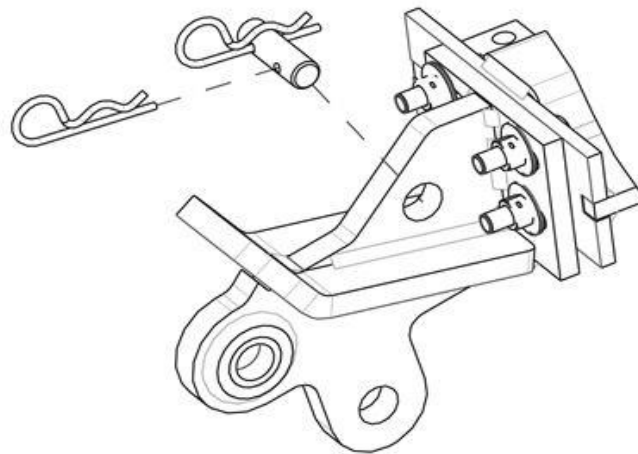

# 5000-039 ASSEMBLY INSTRUCTION

## AGCO GLEANER 3312

**STEP 5:** Attach the 5000-256 & 5000-259 Overbearing Arms to the Mount Brackets using 5/8" X 3" Bolts, Pivot Bushings, & 5/8" Lock Hex Nuts using the upper hole on the arms. Fully tighten all hardware at this time.

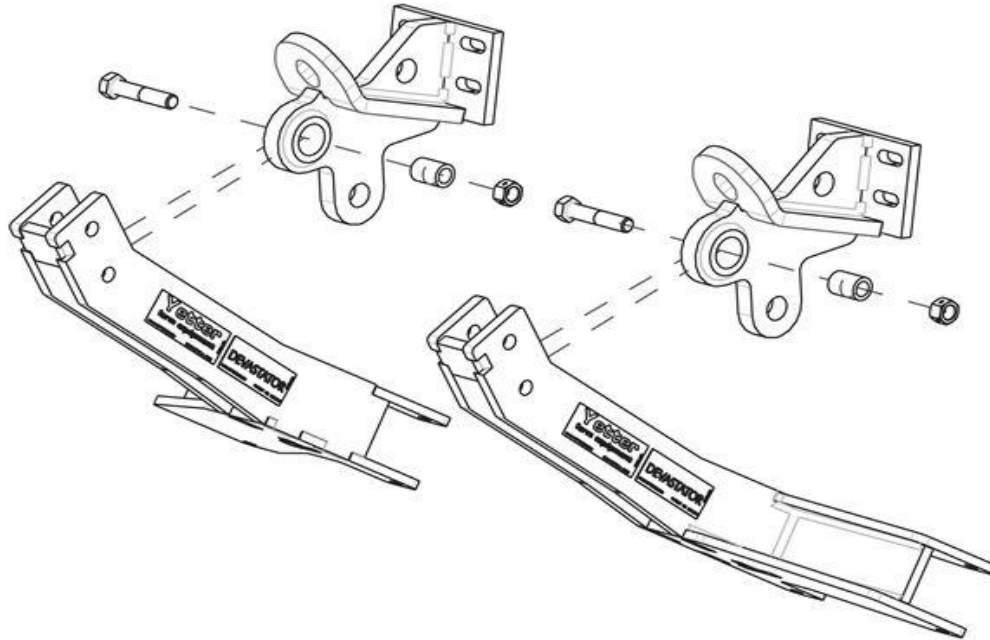

**STEP 6:** Install each Push Rods into the Mount Bracket & attach to the Pivot Arms using 5/8" Shoulder Bolts, 5/8" Washers, & 1/2" Jam Lock Hex Nuts. Use the lower hole on the arm. The Washers are to be installed on each side of the "EYE" on the Push Rod. Now install the Compression Springs, Spring Bushings, & 3/4" Lock Hex Nuts.

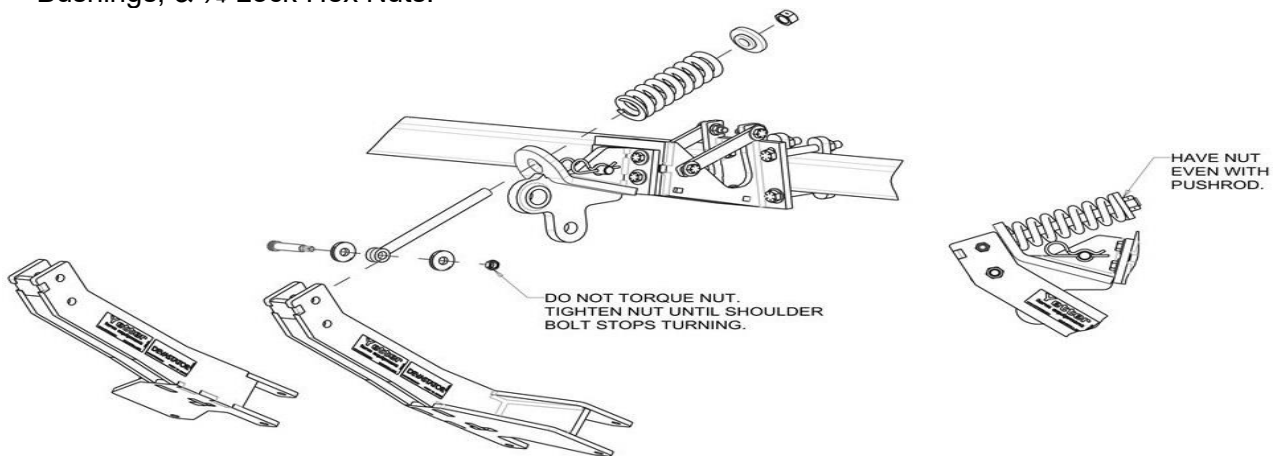

# 5000-039 ASSEMBLY INSTRUCTION

## AGCO GLEANER 3312

**STEP 7:** Attach the Roller Mounts to the Overbearing Arms, & then install the ½" X 3 ¾" Bolts, Spacers, & ½" Lock hex Nuts. Slide the Roller Mount Tubes side to side as needed to clear the end of the Corn Head.

**NOTE:** Make sure the Bearing Support Tab in on the backside of the Bearing Mounting Plate.

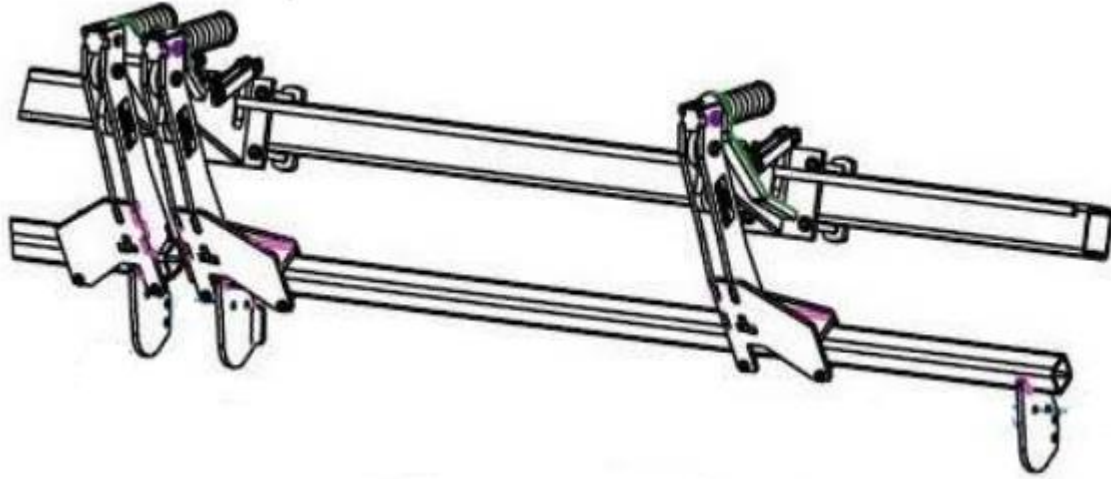

**Step 8:** Insert the shim washer over the shaft on each end of the roller. Install the bearing over the shaft on each end of the roller so that the side of the casting that has the bearing protruding past the housing surface is towards the roller barrel & shim washer. Lift each roller into place, install the ½" X 2 ½" bolts & tighten the ½" lock nuts. Once the roller & bearing hardware is fastened, spin the roller to ensure the bearing was installed correctly. If the roller was installed incorrectly, the roller will not spin or will have drag. Slide the roller mount tube to gain clearance on each end of the corn head & then tighten the hardware.

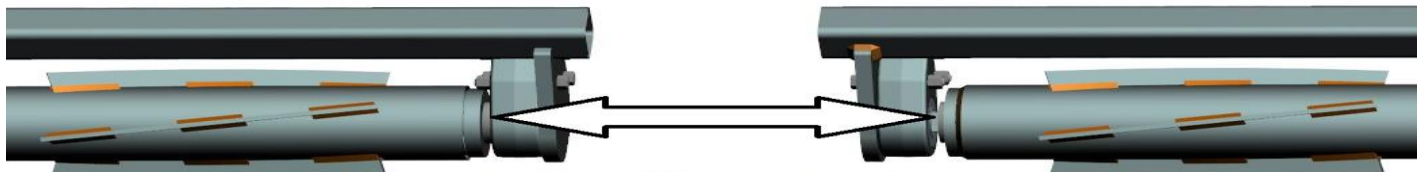
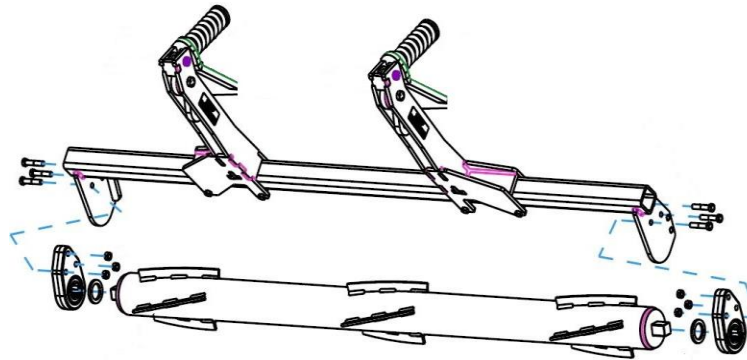

THE SIDE OF THE BEARING ASSEMBLY WHERE THE BEARING IS PROTRUDING MUST BE INSTALLED TOWARD THE ROLLER!

**NOTE:** BEARING HOUSING SHOULD BE LUBRICATED WITH POLYUREA GREASE BEFORE USE AND THEN EVERY 100 HOURS OF OPERATION





# OPERATION

**CORN HEAD ANGLE NEEDS TO BE ADJUSTED BETWEEN 22 – 25° FOR OPTIMUM DEVASTATOR PERFORMANCE. USE THE 5000-455 TO CHECK CORN HEAD ANGLE:**

- Put the combine on a level surface. Lower corn head to your normal working head height.
- Place the magnetic protractor on the stripper plate to get the angle. Adjust the feeder house as needed, fore or aft, to achieve 22 – 25 degrees.



ADJUST SNOOT AS NEEDED WHEN SETTING THE CORRECT HEAD ANGLE

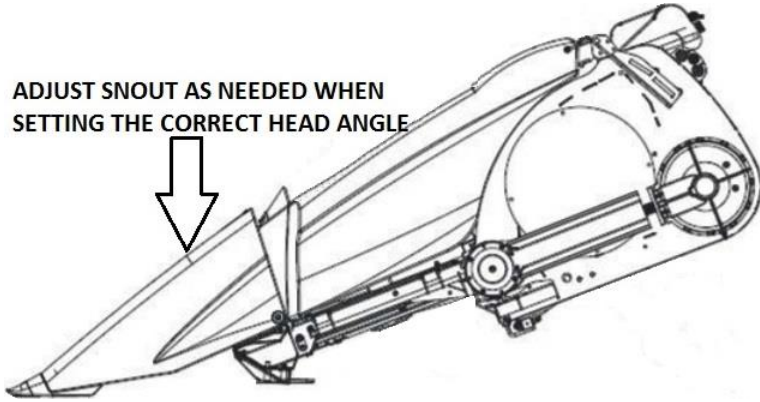
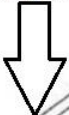

Lower head to operating height & place angle finder on deck plate to check the angle. Adjust fore or aft as needed.



# STORAGE/TRANSPORT

- Head cart may need adjusted to fit the head with devastator correctly. E.g. raising or fore/aft adjustment of saddles/top rail on the head cart.
- If head cart does not have these adjustments, adding a tube extension to top rail or adding extension to saddle/corn head may be required.
- Side to side tilt may need used to clear taller head cart tires or locking the devastator up.
- When disconnecting from the head, leaving pressure on the torsion pivot of the devastator will not damage the devastator.

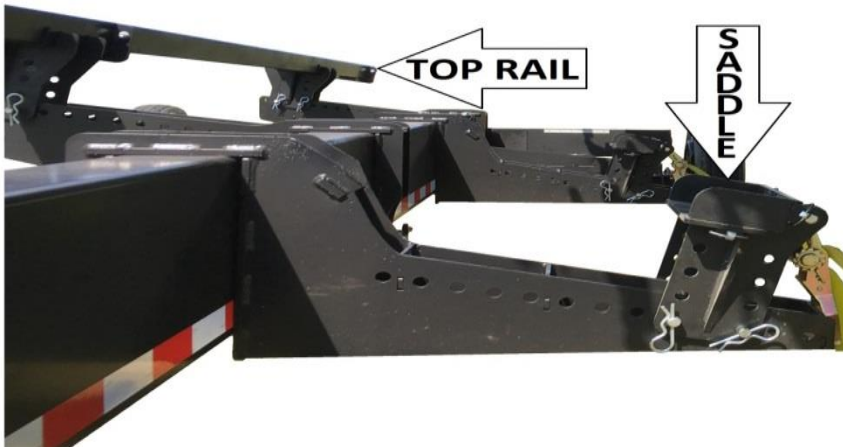



# BEARING REPLACEMENT

Put the bearing housing in a vice, use a pry bar to turn the bearing in the housing parallel with the slots, remove the old bearing, apply anti-seize lubricant to the interior of the bearing housing, insert the new bearing in the slots, & use a pry bar to move back to position. Wobble the bearing around to help work the lubricant into the outer race of the bearing.



# LOCKING UP THE 5000 SERIES STALK DEVASTATOR

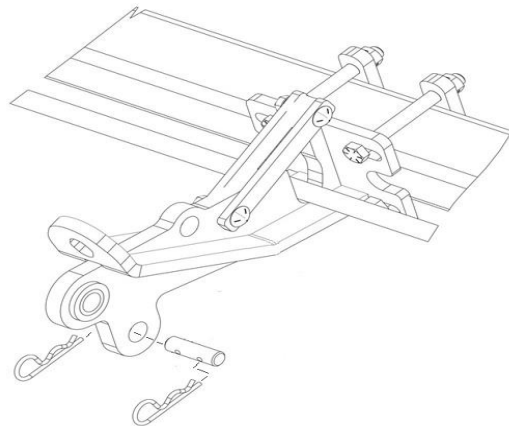

# TROUBLESHOOTING

ISSUE	CAUSE	CORRECTIVE ACTION
Residue Plugging	<ol style="list-style-type: none"> <li>1. Incorrect Head Angle</li> <li>2. Roller Mount Tube incorrectly installed</li> <li>3. Pivot arm orientation incorrect</li> <li>4. Bearing installed incorrectly</li> </ol>	<ol style="list-style-type: none"> <li>1. Adjust head angle to 23 – 25 degrees</li> <li>2. Make sure the Bearing Support Tab is on the backside of the Roller Arm Mount Tube</li> <li>3. Reposition the pivot arm so that it offsets under the snout &amp; not under the row</li> <li>4. Make sure the side of the bearing that protrudes outside of the cast housing is facing toward the roller (each roller should spin freely by hand)</li> <li>5. Order the 5000-080 Set Back Kit (order 2 per roller)</li> <li>6. Back the nut off of the push rod until the nut is flush</li> </ol>
Stalk aren't "devastated"	<ol style="list-style-type: none"> <li>1. Insufficient spring down pressure</li> <li>2. Operating corn head too high</li> </ol>	<ol style="list-style-type: none"> <li>1. Tighten push rod nut on spring bushing more</li> <li>2. Lower corn head until the rollers engage</li> </ol>
Corn Head won't fit on head cart	<ol style="list-style-type: none"> <li>1. Devastators bottom out</li> <li>2. Roller won't clear cart tire</li> </ol>	<ol style="list-style-type: none"> <li>1. Adjust top rail &amp; saddles higher on cart</li> <li>2. Order 5000-082 Lift Kit (raises roller 2")</li> </ol>

# 5000-023C PARTS IDENTIFICATION

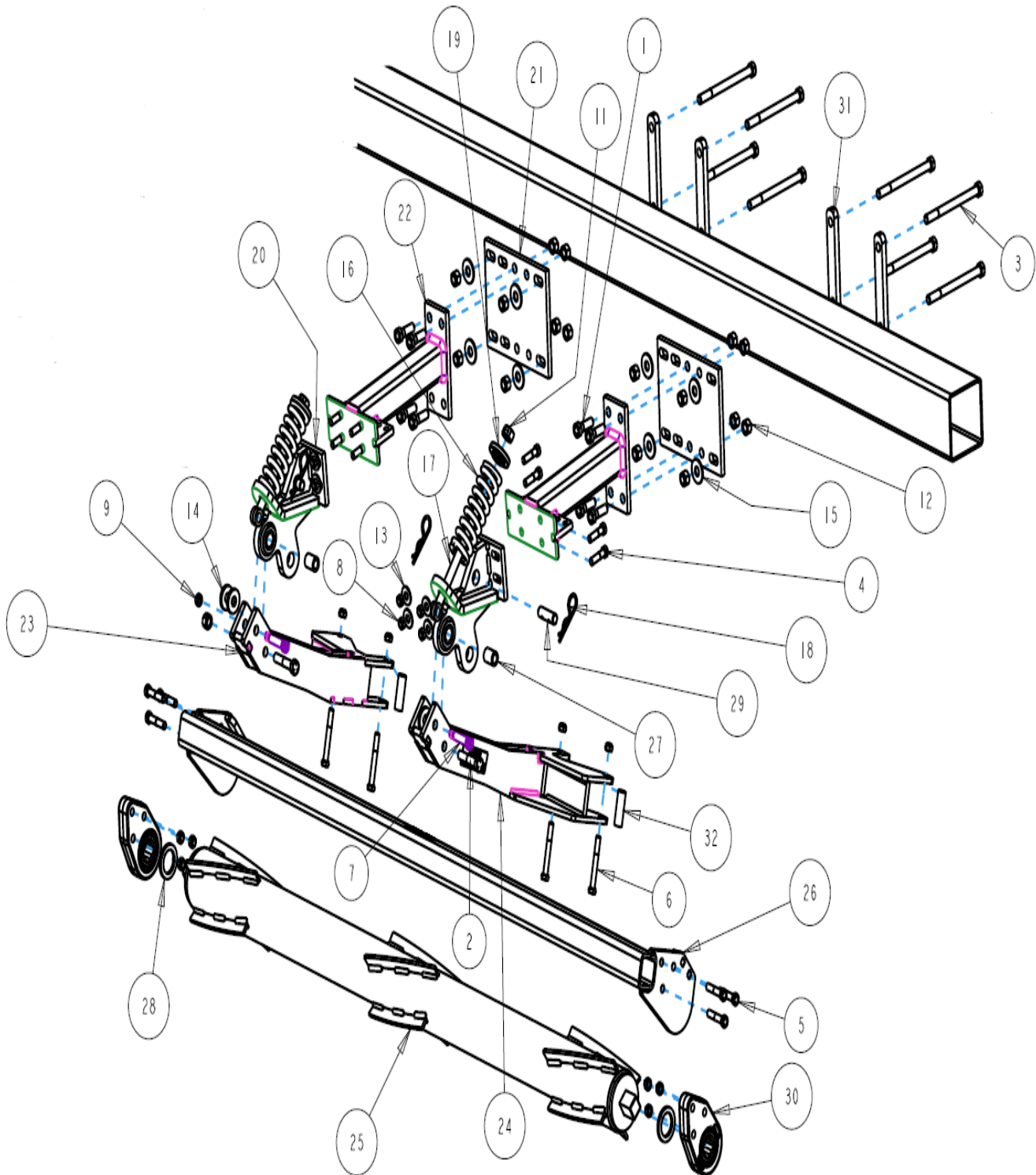

**\*\*PART IDENTIFICATION TABLE ON THE FOLLOWING PAGE\*\***

# 5000-023C PARTS IDENTIFICATION

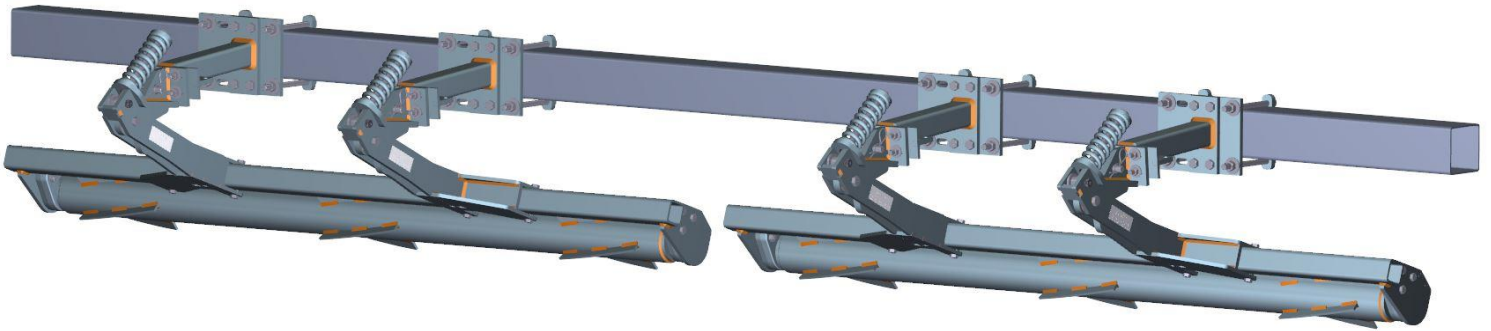

ITEM	PART NO.	DESCRIPTION	QTY
1	2502-322	5/8-11 X 2 CAP SCREW GRADE 8	16
2	2502-325	5/8-11 X 3 CAP SCREW GRADE 5	4
3	2502-342	5/8-11 x 8 CAP SCREW GRADE 8	16
4	2502-350	½-13 X 2 CAP SCREW GRADE 8	16
5	2502-353	½-13 X 2.5 CAP SCREW GRADE 8	12
6	2502-365	½-13 X 3.75 CAP SCREW GRADE 5	8
7	2510-121	5/8 X 2.25 SHOULDER BOLT ½-13 THREAD	4
8	2520-362	½-13 HEX LOCK NUT GRADE 8	36
9	2520-364	½-13 JAM LOCK NUT	4
10	2520-459	5/8-11 LOCK HEX NUT GRADE 5	4
11	2520-515	¾-10 LOCK HEX NUT GRADE 2	4
12	2520-603	5/8 TOP LOCK HEX NUT GRADE 8	32
13	2526-351	½ STANDARD FLAT WASHER	16
14	2526-449	5/8 FLAT WASHER 1/4" THICK	8
15	2526-451	5/8 STANDARD FLAT WASHER	16
16	2550-709	SPRING ½" WIRE 2.5 O.D. X 1.5 I.D. X 7.25 LENGTH	4
17	2570-126	¾ X 10 EYEBOLT	4
18	2570-465	HAIRPIN COTTER	8
19	2975-302	SPRING BUSHING	4
20	5000-135	ARM MOUNT	4
	2528-369	BEARING SLEEVE	4
21	5000-247	MOUNT PLATE	4
22	5000-248	MOUNT EXTENSION	4
23	5000-256	ARM-LEFT HAND	2
24	5000-259	ARM-RIGHT HAND	2
25	5000-272	3 ROW 30" ROLLER	2
26	5000-275A	ROLLER MOUNT	2
27	5000-318	PIVOT BUSHING	4
28	5000-322	SHIM WASHER	4
29	5000-323	LOCK UP PIN	4
30	5000-355	BEARING ASSEMBLY	4
	2550-059	BEARING	4
31	5000-365	MOUNT CLAMP PLATE	8
32	5000-378	SPACER BUSHING	8

# 5000-024C PARTS IDENTIFICATION

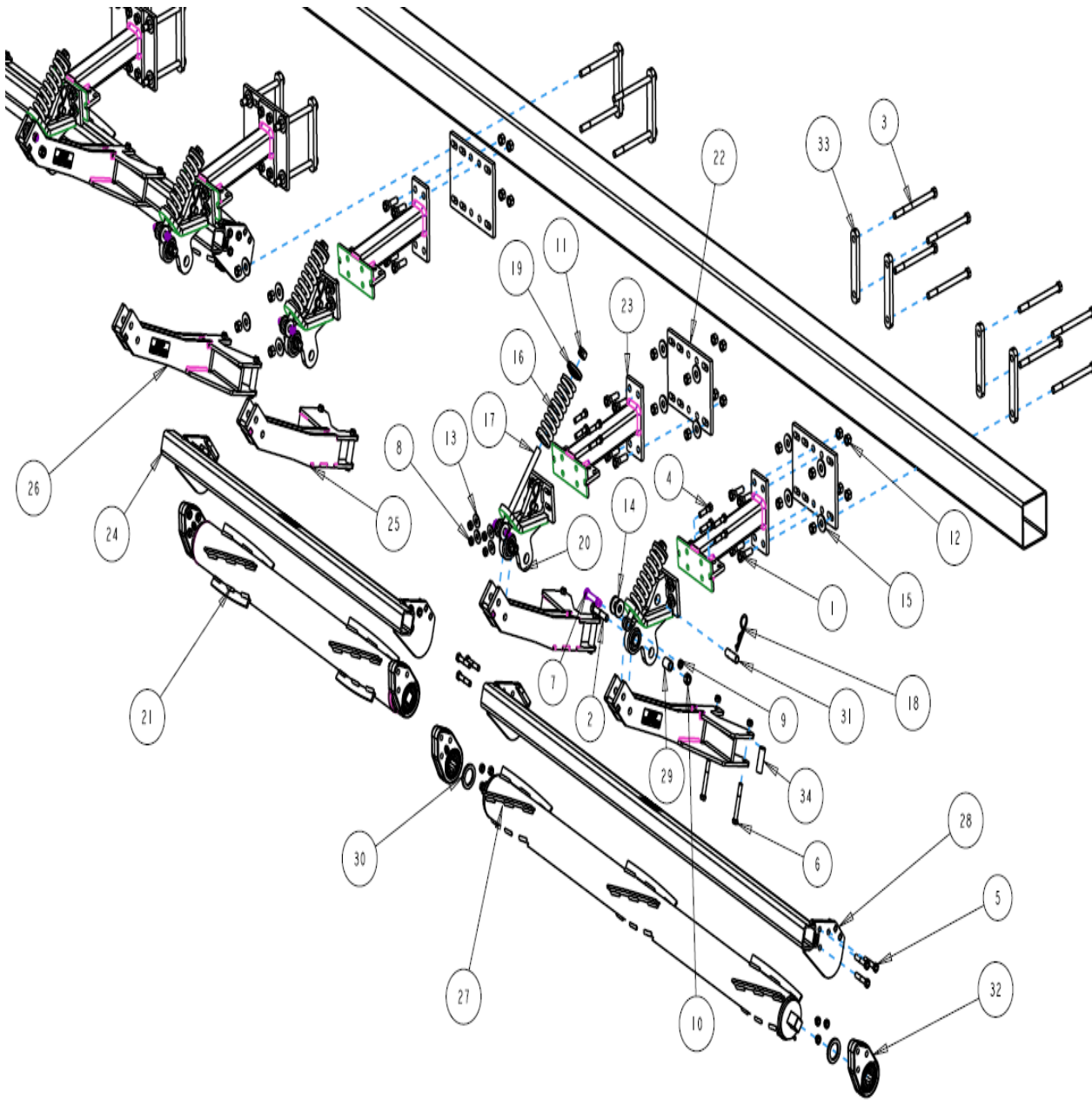

**\*\*PART IDENTIFICATION TABLE ON THE FOLLOWING PAGE\*\***



# 5000-024C PARTS IDENTIFICATION

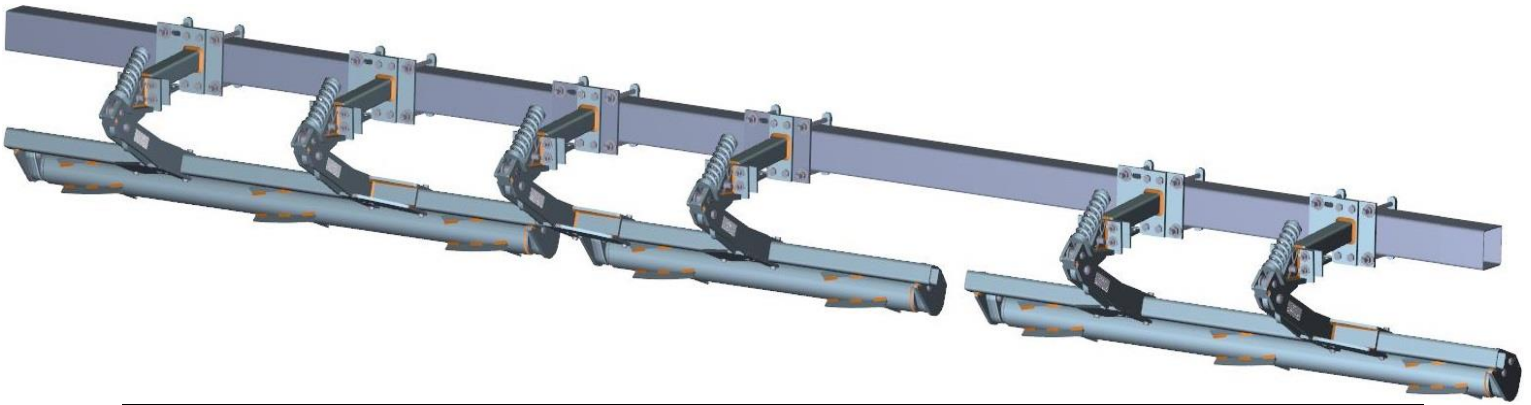

ITEM	PART NO.	DESCRIPTION	QTY
1	2502-322	5/8-11 X 2 CAP SCREW GRADE 8	24
2	2502-325	5/8-11 X 3 CAP SCREW GRADE 5	6
3	2502-342	5/8-11 x 8 CAP SCREW GRADE 8	24
4	2502-350	½-13 X 2 CAP SCREW GRADE 8	24
5	2502-353	½-13 X 2.5 CAP SCREW GRADE 8	18
6	2502-365	½-13 X 3.75 CAP SCREW GRADE 5	12
7	2510-121	5/8 X 2.25 SHOULDER BOLT ½-13 THREAD	6
8	2520-362	½-13 HEX LOCK NUT GRADE 8	54
9	2520-364	½-13 JAM LOCK NUT	6
10	2520-459	5/8-11 LOCK HEX NUT GRADE 5	6
11	2520-515	¾-10 LOCK HEX NUT GRADE 2	6
12	2520-603	5/8 TOP LOCK HEX NUT GRADE 8	48
13	2526-351	½ STANDARD FLAT WASHER	24
14	2526-449	5/8 FLAT WASHER 1/4" THICK	12
15	2526-451	5/8 STANDARD FLAT WASHER	24
16	2550-709	SPRING ½" WIRE 2.5 O.D. X 1.5 I.D. X 7.25 LENGTH	6
17	2570-126	¾ X 10 EYEBOLT	6
18	2570-465	HAIRPIN COTTER	12
19	2975-302	SPRING BUSHING	6
20	5000-135	ARM MOUNT	6
	2528-369	BEARING SLEEVE	6
21	5000-203B	ROLLER 48"	1
22	5000-247	MOUNT PLATE	6
23	5000-248	MOUNT EXTENSION	6
24	5000-255	2 ROW ROLLER MOUNT	1
25	5000-256	ARM-LEFT HAND	3
26	5000-259	ARM-RIGHT HAND	3
27	5000-272	3 ROW 30" ROLLER	2
28	5000-275A	3 ROW 30" ROLLER MOUNT	2
29	5000-318	PIVOT BUSHING	6
30	5000-322	SHIM WASHER	6
31	5000-323	LOCK UP PIN	6
32	5000-355	BEARING ASSEMBLY	6
	2550-059	BEARING	6
33	5000-365	MOUNT CLAMP PLATE	12
35	5000-378	SPACER BUSHING	12



# 5000-035A PARTS IDENTIFICATION

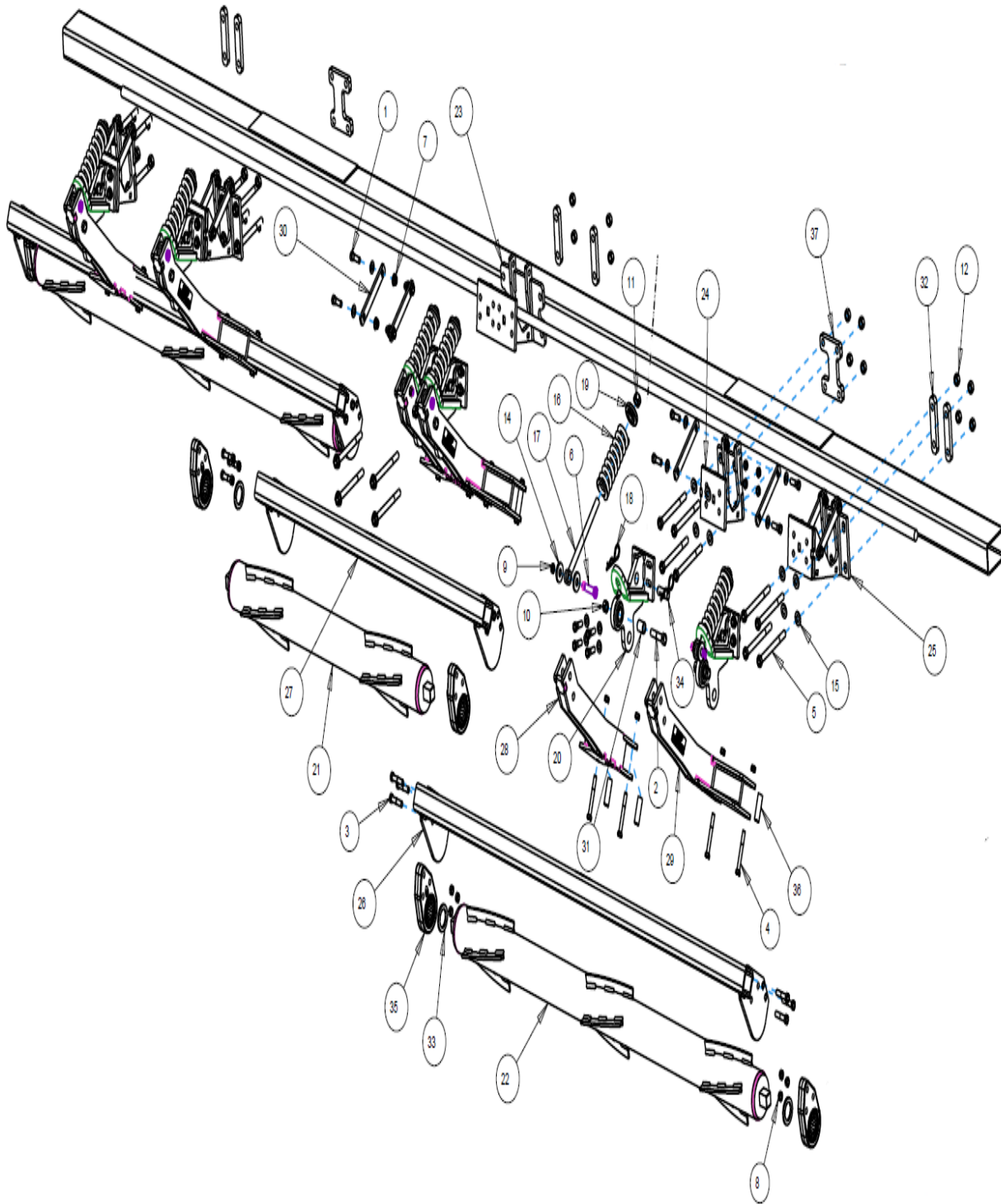

**\*\*PART IDENTIFICATION TABLE ON THE FOLLOWING PAGE\*\***

# 5000-035A PARTS IDENTIFICATION

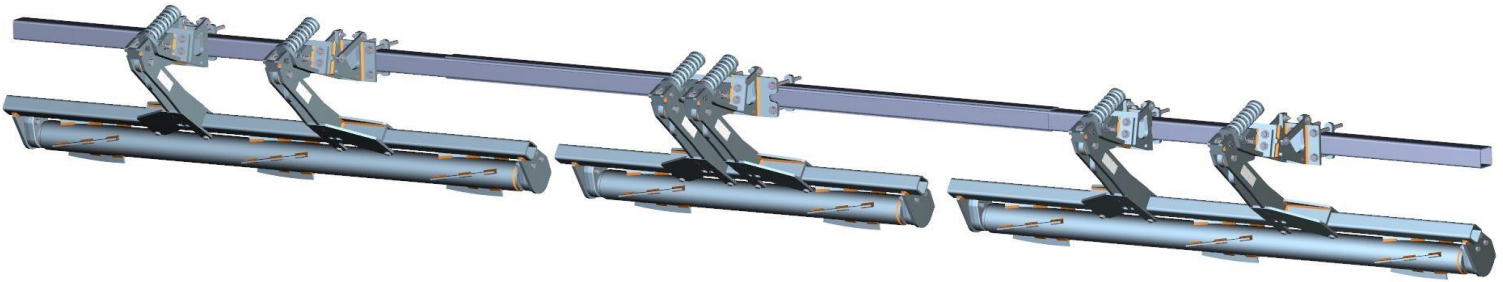

ITEM	PART NO.	DESCRIPTION	QTY
1	2502-311	½-13 X 1.75 CAP SCREW GRADE 8	44
2	2502-325	5/8-11 X 3 CAP SCREW GRADE 5	6
3	2502-353	½-13 X 2.5 CAP SCREW GRADE 8	18
4	2502-365	½-13 X 3.75 CAP SCREW GRADE 5	12
5	2502-396	5/8 X 7 CAP SCREW GRADE 8	20
6	2510-121	5/8 X 2.25 SHOULDER BOLT ½-13 THREAD	6
7	2520-361	½-13 FLANGE HEX NUT GRADE 5	20
8	2520-362	½-13 HEX LOCK NUT GRADE 8	54
9	2520-364	½-13 JAM HEX NUT	6
10	2520-459	5/8-11 LOCK HEX NUT GRADE 5	6
11	2520-515	¾-10 LOCK HEX NUT GRADE 2	6
12	2520-603	5/8-11 HEX TOP LOCK NUT GRADE 8	20
13	2526-352	½ STANDARD FLAT WASHER	44
14	2526-449	5/8 FLAT WASHER 1/4" THICK	12
15	2526-453	5/8 SAE FLATWASHER	20
16	2550-709	SPRING ½" WIRE 2.5 O.D. X 1.5 I.D. X 7.25 LENGTH	6
17	2570-126	¾ X 10 EYEBOLT	6
18	2570-465	HAIRPIN COTTER	12
19	2975-302	SPRING BUSHING	6
20	5000-135	ARM MOUNT	6
	2528-369	BEARING SLEEVE	6
21	5000-203B	ROLLER 48"	1
22	5000-211B	ROLLER 76"	2
23	5000-246	DOUBLE MOUNT	1
24	5000-251	RIGHT HAND OFFSET MOUNT	2
25	5000-252	LEFT HAND OFFSET MOUNT	2
26	5000-254	3 ROW ROLLER MOUNT	2
27	5000-255	2 ROW ROLLER MOUNT	1
28	5000-256	LEFT HAND MOUNT ARM	3
29	5000-259	RIGHT HAND MOUNT ARM	3
30	5000-309	SUPPORT STRAP	10
31	5000-318	PIVOT BUSHING	6
32	5000-319	MOUNT STRAP	6
33	5000-322	SHIM WASHER	6
34	5000-323	LOCK UP PIN	6
35	5000-355	BEARING ASSEMBLY	6
	2550-059	BEARING	6
36	5000-378	SPACER BUSHING	12
37	5000-400	OFFSET CLAMP BRACKET	2

# 5000-039 PARTS IDENTIFICATION

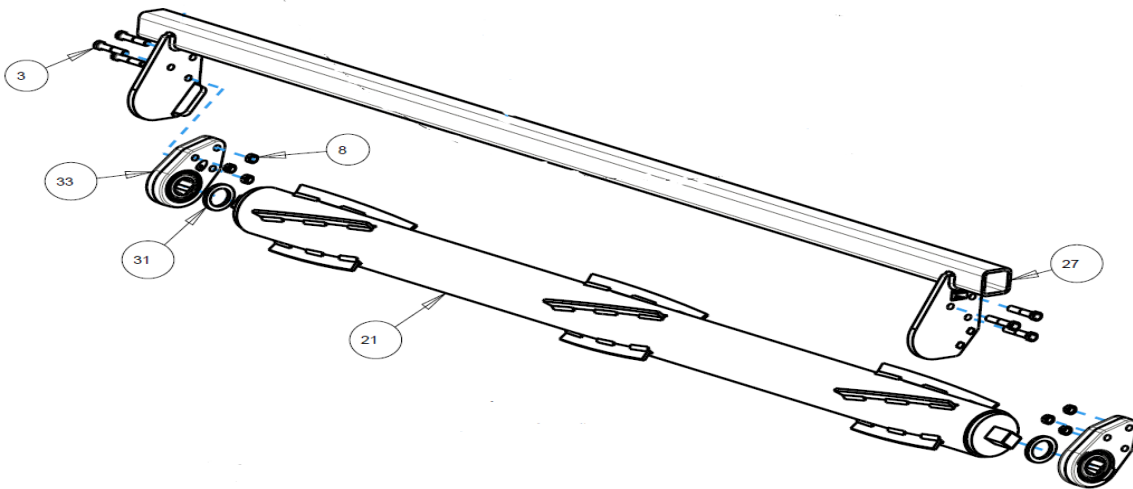
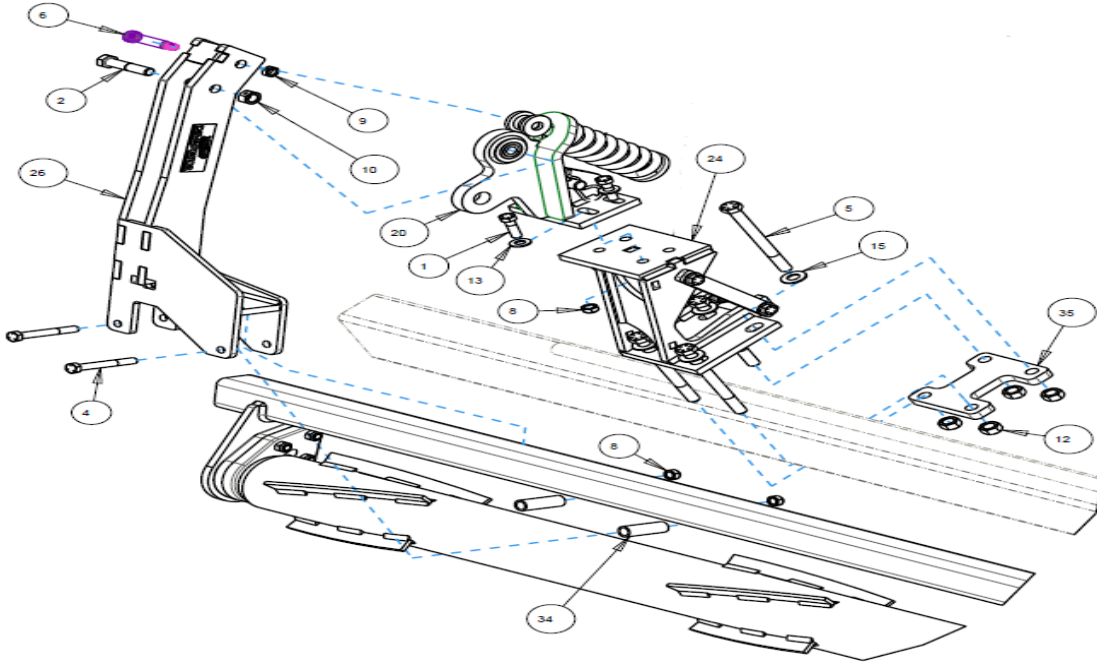
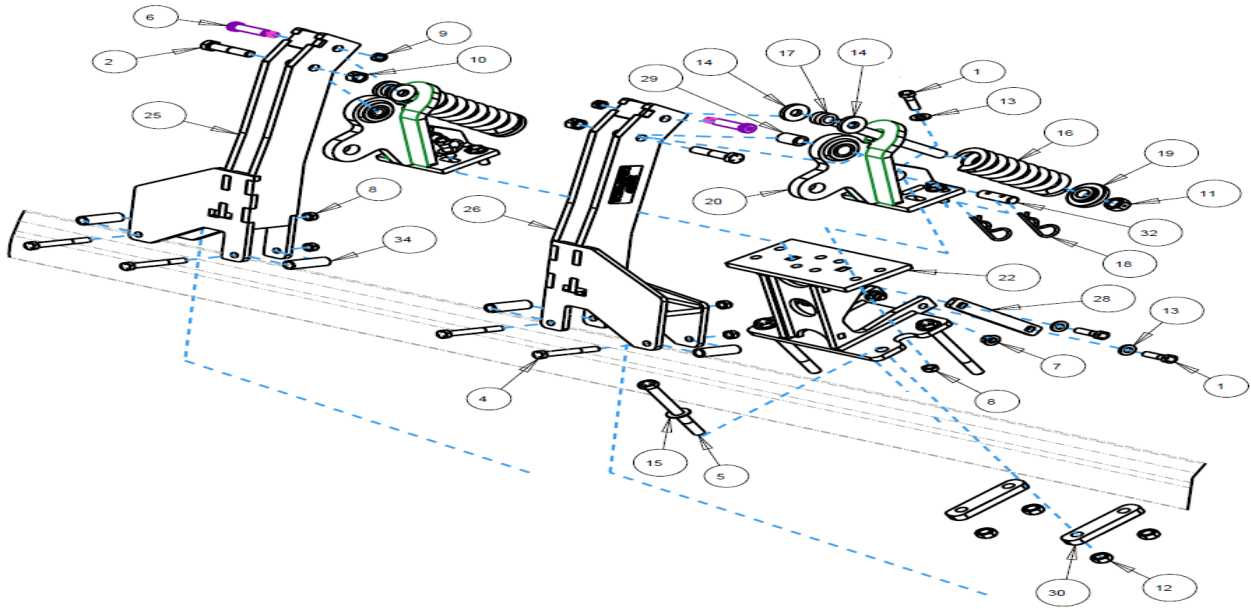

## 5000-039 PARTS IDENTIFICATION



ITEM	PART NO.	DESCRIPTION	QTY
1	2502-311	½-13 X 1.75 CAP SCREW GRADE 8	52
2	2502-325	5/8-11 X 3 CAP SCREW GRADE 5	8
3	2502-353	½-13 X 2.5 CAP SCREW GRADE 8	24
4	2502-365	½-13 X 3.75 CAP SCREW GRADE 5	16
5	2502-396	5/8 X 7 CAP SCREW GRADE 8	20
6	2510-121	5/8 X 2.25 SHOULDER BOLT ½-13 THREAD	8
7	2520-361	½-13 FLANGE HEX NUT GRADE 5	20
8	2520-362	½-13 HEX LOCK NUT GRADE 8	72
9	2520-364	½-13 JAM HEX NUT	8
10	2520-459	5/8-11 LOCK HEX NUT GRADE 5	8
11	2520-515	¾-10 LOCK HEX NUT GRADE 2	8
12	2520-603	5/8-11 HEX TOP LOCK NUT GRADE 8	20
13	2526-352	½ STANDARD FLAT WASHER	52
14	2526-449	5/8 FLAT WASHER 1/4" THICK	16
15	2526-453	5/8 SAE FLATWASHER	20
16	2550-709	SPRING ½" WIRE 2.5 O.D. X 1.5 I.D. X 7.25 LENGTH	8
17	2570-126	¾ X 10 EYEBOLT	8
18	2570-465	HAIRPIN COTTER	16
19	2975-302	SPRING BUSHING	8
20	5000-135	ARM MOUNT	8
	2528-369	BEARING SLEEVE	8
21	5000-211B	ROLLER 76"	4
22	5000-246	DOUBLE MOUNT	3
23	5000-251	RIGHT HAND OFFSET MOUNT	1
24	5000-252	LEFT HAND OFFSET MOUNT	1
25	5000-256	LEFT HAND MOUNT ARM	4
26	5000-259	RIGHT HAND MOUNT ARM	4
27	5000-261	ROLLER MOUNT 3 ROW "LONG"	4
28	5000-309	SUPPORT STRAP	10
29	5000-318	PIVOT BUSHING	8
30	5000-319	MOUNT STRAP	6
31	5000-322	SHIM WASHER	8
32	5000-323	LOCK UP PIN	8
33	5000-355	BEARING ASSEMBLY	8
	2550-059	BEARING	6
34	5000-378	SPACER BUSHING	16
35	5000-400	OFFSET CLAMP BRACKET	2





A Tradition of Solutions since 1930

Yetter Farm Equipment Co

PO BOX 358 109 S. McDonough

Colchester, IL 62326-0358

Phone: 309-776-4111

Toll Free: 800-447-5777

Email: [info@yetterco.com](mailto:info@yetterco.com)

For updated models and manuals visit the Yetter website:

[www.yetterco.com](http://www.yetterco.com)

© Yetter Farm Equipment Co. All Rights Reserved

2565-784\_REV\_E • 01/2024