

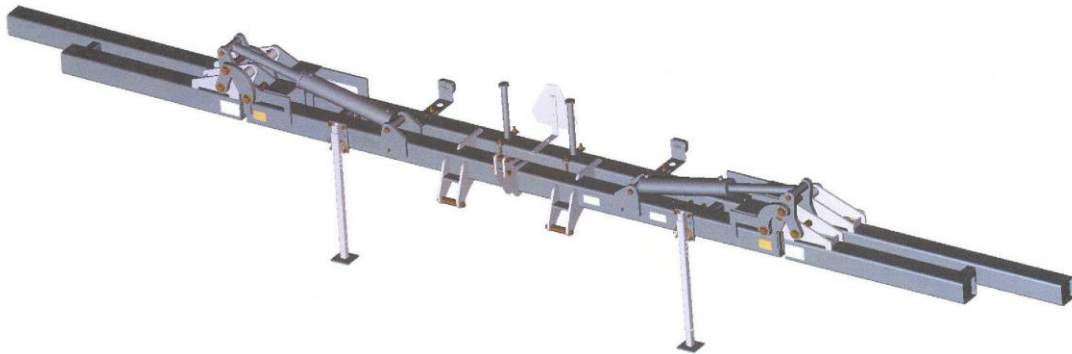

## 3800 SERIES HEAVY DUTY FOLDING TOOLBAR

2565-772\_REV\_H • 07/2021  
**OPERATOR'S MANUAL**  
PART IDENTIFICATION



**YETTER MANUFACTURING CO.**

*FOUNDED 1930*

Colchester, IL 62326-0358

Toll free: 800/447-5777

309/776-3222 (Fax)

Website: [www.yetterco.com](http://www.yetterco.com)

E-mail: [info@yetterco.com](mailto:info@yetterco.com)

# YETTER

# FOREWORD

You've just joined an exclusive but rapidly growing club.

For our part, we want to welcome you to the group and thank you for buying a Yetter product.

We hope your new Yetter implement will help you achieve both increased productivity and increased efficiency so that you may generate more profit. This operator's manual has been designed into six major sections.

Foreword, Safety Precautions, assembly instructions, Operation, parts identification and troubleshooting.

It is important the owner/operator knows the implement model number and serial number. Write the serial and model number in the space provided and use it in all correspondence when referring to the implement.

Throughout the manual references may be made to left side and right side. These terms are used as viewed from the operator's seat facing the front of the tractor.

 This **SAFETY ALERT SYMBOL** indicates important safety messages in the manual. When you see this symbol, be alert to the possibility of **PERSONAL INJURY** and carefully read the message that follows.

The word **NOTE** is used to convey information that is out of context with the manual text. It contains special information such as specifications, techniques, reference information and other information of a supplementary nature. The word **IMPORTANT** is used in the text when immediate damage will occur to the machine due to improper technique or operation. Important will apply to the same information as specified by note only of an immediate and urgent nature.

It is the responsibility of the user to read the operator's manual and comply with the safe and correct operating procedure and to lubricate and maintain the product according to the maintenance schedule in the operator's manual.

The user is responsible for inspecting his machine and for having parts repaired or replaced when continued use of the product would cause damage or excessive wear to the other parts.

 It is the user's responsibility to deliver his machine to the Yetter dealer who sold him the product for service or replacement of defective parts that are covered by the warranty policy.

If you are unable to understand or follow the instructions provided in the publication, consult you local Yetter dealer or contact:

## YETTER MANUFACTURING CO.

309/776-4111

800/447-5777

309/776-3222 (FAX)

Website: [www.yetterco.com](http://www.yetterco.com)

E-mail: [info@yetterco.com](mailto:info@yetterco.com)

## WARRANTY POLICY

Yetter Manufacturing warrants all products manufactured and sold by it against defects in material. This warranty being expressly limited to replacement at the factory of such parts or products as will appear to be defective after inspection. This warranty does not obligate the Company to bear cost of labor in replacement of parts. It is the policy of the company to make improvements without incurring obligations to add them to any unit already sold. No warranty is made or authorized to be made, other than herein set forth. This warranty is in effect for one year after purchase.

Model Number: \_\_\_\_\_

Serial Number: \_\_\_\_\_

Dealer : \_\_\_\_\_

The serial and model numbers are located on the top of the left hitch plate.

**Yetter Manufacturing warrants its own products only and cannot be responsible for damage to equipment on which mounted.**

## SAFETY PRECAUTIONS

You can make your farm a safer place to live and work if you observe the safety precautions given. Study these precautions carefully and insist that those working with you and for you follow them.

Finally, remember this: an accident is usually caused by someone's carelessness, neglect or oversight.



### DANGER

Inspect and replace worn or frayed hydraulic hose, keep all connections tight. Escaping hydraulic fluid under pressure can have sufficient force to penetrate the skin and cause serious personal injury. Fluid escaping from a small hole can be almost invisible. Use a piece of cardboard or wood rather than the hands to search for suspected leaks.



### CAUTION

Consult your implement and tractor operator's manual for correct and safe operating practices. Be aware of towed implement width and allow safe clearance.



### CAUTION: SAFETY SIGNS

Safety decals are placed on the implement to alert the operator and others to the risk of personal injury or unsafe operation during normal operations and servicing.

1. The safety decals must be kept clean and in good condition to ensure that they are legible.
2. Safety decals must be replaced if they are missing or illegible.
3. When components are replaced during repair or servicing, check that the new components include the necessary safety signs.
4. Replacement safety decals may be obtained from your local Yetter dealer.



### WARNING

Never clean, lubricate or adjust a machine that is in motion. Always install the transport lock pins and bracket when transporting for any length of time or on public roadways.

If required to service unit in raised position, be sure to install all transport lock pins and locking bracket.

Be sure the implement is securely locked in the 3-point quick hitch before operating.

Do not allow children to operate this equipment.

Do not allow riders on the tractor or implement.

Use speeds and caution dictated by the terrain being traversed. Do not operate on any slope steep enough to cause tipping or loss of control.

Be sure all personnel are clear of the immediate area before operating.

Read and understand the operator's manual and require all other persons who will operate the equipment to do the same.

In operating on public roadways, where legal, be certain all lighting is operating properly and observe all traffic laws. Ensure slow moving vehicle emblem on tractor is visible.

Beware of increased stopping distances and control effort when operating with implements attached.

Be familiar with all tractor and implement controls and be prepared to stop engine and implements quickly in an emergency.

**FAILURE TO HEED MAY RESULT IN PERSONAL INJURY OR DEATH**

## TABLE OF CONTENTS



Forward.....	pg. 2
Warranty.....	pg. 2
Safety Information.....	pg. 2-3
Table of Contents.....	pg. 4
Torque Recommendations.....	pg. 5
Assembly Instruction.....	pg. 6-9
Operation.....	pg. 10-11
Parts Identification.....	pg. 12-26
Troubleshooting.....	pg. 27

## BOLT TORQUE

**READ THESE INSTRUCTIONS FIRST:**

1. Improperly tightened bolts will result in damage, breakage, expense, and down time.
2. Always replace bolts with the specified grade and type.
3. Torque properly before first use of the machine and every 2-4 hours of use until you are sure bolts are staying tight.
4. The chart below is a guide for proper torque. Use it unless a specified torque is called out elsewhere in the manual.
5. Torque is the force you apply to the wrench handle or the cheater bar, times the length of the handle or bar.
6. Use a torque wrench whenever possible.

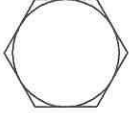
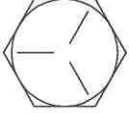
The following table shows torque in ft. lbs.

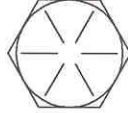
BOLT DIA. AND THREADS PER INCH		 OR 	
	GRADE 2	GRADE 5 A-325	GRADE 8
3/8-16	25	35	50
7/16-14	35	55	80
1/2-13	55	85	125
9/16-12	75	125	175
5/8-11	105	170	235
3/4-10	185	305	425
7/8-9	170	445	690
1-8	260	670	1030
1 1/8-7	365	900	1460
1 1/4-7	515	1275	2060
1 3/8-6	675	1675	2700
1 1/2-6	900	2150	3500
1 3/4-5	1410	3500	5600



**WARNING:** Never work around the toolbar / implement while in a raised position without using safety lockups.

# 3800 SERIES HYDRAULIC ASSEMBLY

1. Lubricate the o-ring on each of the restricted 90-degree fittings and install into the cylinder ports. **DO NOT OVER TIGHTEN AND DISTORT THE METAL BACK-UP WASHER.** Position the fitting by turning it out (counter clockwise) to a maximum of one complete turn and tighten the jam-nut.
2. Connect the 1/4" x 110" hoses on opposite ports of a "T" fittings. Then connect the hose fittings the restricted 90-degree fittings on the hydraulic cylinders.
3. Connect the 1/4"x 80" hoses to the remaining "T" ports and tighten **ALL** connections.

Adapters are provided for the hoses to connect to standard 3/4-16 straight thread quick coupler tips such as Case-IH part no. 1285718\* or Deere part no. AR945222.

4. Using the cable ties furnished, tie the outer port hoses to the lower ends of each cylinder and the hose to the toolbar on each side of the "T"s and at 2 to 3 foot intervals between.
5. **IMPORTANT:** Be sure to purge the air from the hydraulic cylinders. This insures smooth wing operation.



## CAUTION STAND CLEAR OF FOLDING WINGS!

### HYDRAULIC ASSEMBLY

DET	QTY	PART NO.	DESCRIPTION
1	4	2515-366	HOSE 1/4 X 110" W/-6 JIC ENDS
2	2	2515-363	HOSE, 1/4 X 80" W/-6 JIC ENDS
3	12	2515-405	CABLE TIE, BLACK, 1/2" X 42"
4	2	2515-326	TEE, -6 / -6 / -6 JIC
5	4	2515-830	2501-06-12 90 DEG. FITTING (RESTRICTED)
6	2	2515-327	ADAPTOR, 3/4-16 SAE TO -6 JIC
7	2	3841-300	5 X 24 HYDRAULIC CYLINDER
	1	2515-847	SEAL KIT
	2	3841-301	PIN - BASE
	2	3841-302	PIN - ROD
	8	2527-566	1.5" WASHER
	8	2530-212	3/8 X 2 ROLL PIN

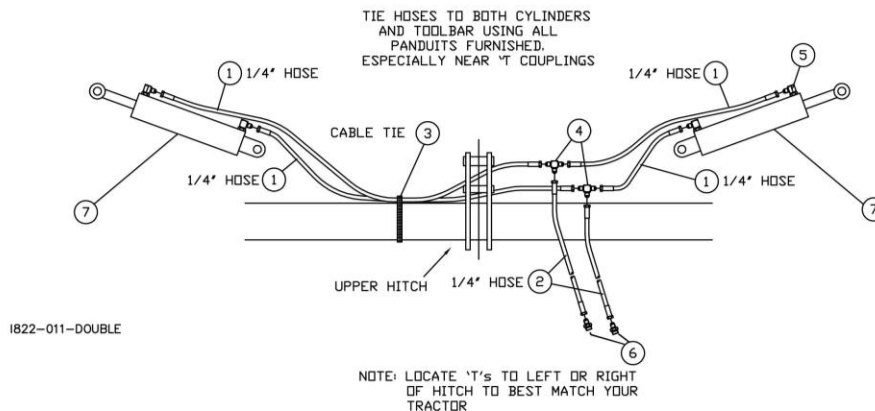

# SAFETY LIGHTING ASSEMBLY AND PARTS IDENTIFICATION

## 3400-175 - TOOLBAR LIGHT KIT

DET.	QTY.	PART NO.	DESCRIPTION
1	2	1300-137	AMBER LIGHT ASSEMBLY
2	2	3400-227	LIGHT BRACKET W.A., AMBER LAMP
3	2	2565-808	AMBER REFLECTOR, 1.97 X 6.3"
4	1	2520-357	1/2-3 LOCK HEX NUT ZP
5	2	2520-206	5/16-18 FLANGE LOCK NUT
6	2	1300-436	AMBER LIGHT BRACKET
7	1	2502-300	1/2-13 X 1-1/4 HHCS GR. 2 ZP
8	2	2505-205	5/16-18 X 3/4 CAR BLT GR.5
9	1	1300-448	LAMP, AMBER
10	4	2502-195	M8 X 12MM HHCS GR.5 ZP
11	2	3400-359	LIGHT BRACKET, RED LAMP
12	2	1300-447	LAMP, RED
13	1	1300-446	HARNES, COMMON WIRING
14	8	2515-405	CABLE TIE, BLACK
15	1	1300-445	MODULE, IMPLEMENT TURN SIGNAL

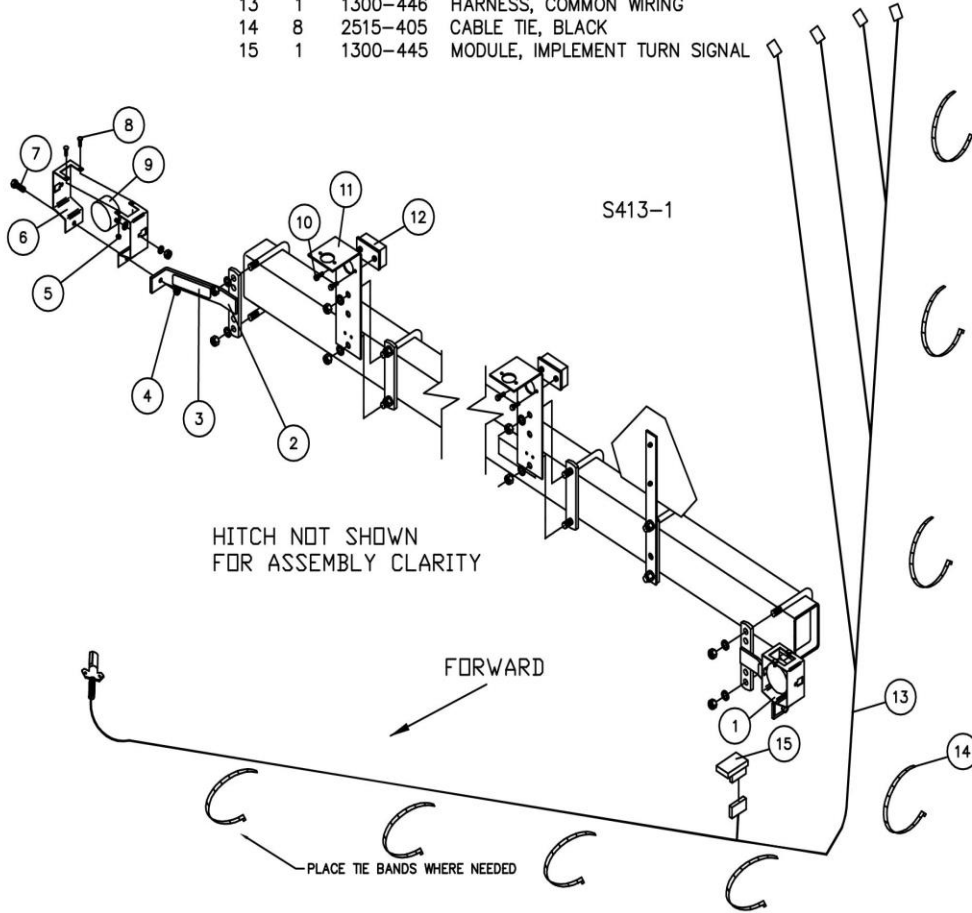

# SAFETY EQUIPMENT ASSEMBLY AND PARTS IDENTIFICATION

## SMV ASSEMBLY

1. Mount SMV emblem as shown with point of triangle up as near operators left of center as possible. Face so emblem is visible from rear of equipment.

DET	QTY	PART NO.	DESCRIPTION
1	1	2570-472	SMV EMBLEM WITH BACKING
2	1	3500-313	SMV BRACKET
3	1	2570-478	3/4 X 7 X 9 U-BOLT, ZP
4	2	2525-501	3/4 MED LOCKWASHER ZP
5	2	2520-504	3/4-10 HEX NUT ZP
6	2	2502-105	1/4-20 X 3/4 HHCS GR 5 ZP
7	2	2520-152	1/4-20 HEX NUT ZP

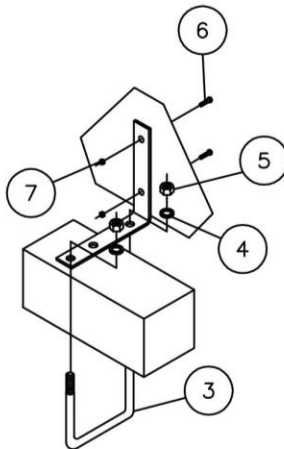



# ASSEMBLY

## OPTIONAL EQUIPMENT:

### GAUGE WHEELS

Gauge wheels maintain the frame at a constant level in respect to the ground contour.

Mount each gauge wheel an equal distance from the center of the main frame.



**CAUTION:** ON 3800 MODELS, BEFORE ACTIVATING FOLDING HINGE CHECK FOR OBSTRUCTIONS, ESPECIALLY CHECK GAUGE WHEEL POSITIONS TO BE SURE THAT GAUGE WHEELS ARE SET TO CLEAR TRACTOR AND OPERATOR.



**CAUTION:** CLEAR ALL PERSONNEL FROM AREA BEFORE FOLDING OR UN-FOLDING TOOLBAR.



**CAUTION: STAND CLEAR OF FOLDING WING!**

## ATTACHING 3800 TOOLBAR TO TRACTOR



**CAUTION:** BEFORE ATTACHING TO TRACTOR, BE SURE HITCH PINS ARE COMPLETELY ASSEMBLED TO MATCH YOUR TRACTOR HITCH.



**CAUTION:** MAKE CERTAIN THAT CENTER LINK AND QUICK COUPLER ARE LOCKED AND LOCK PINS ARE PROPERLY INSTALLED BEFORE MOVING.

### Detaching from Tractor



**CAUTION:** To avoid injury from escaping hydraulic oil under pressure, relieve the pressure in the system before removing hoses from breakaway couplers.

**IMPORTANT:** To prevent possible tipping, install parking stands on toolbar before disconnecting from tractor.

# FIELD OPERATION

## PRE-OPERATION CHECK LIST:

Use this checklist each time you operate the 3800 Toolbar in the field. It will help you obtain satisfactory field operation quickly.

1. Tractor sway blocks in upper position.
2. Center link adjusted for level frame in field operation.
3. Tractor lift links set in lateral float.
4. Hitch pins fastened and correct spacers used.
5. Quick couplers latched.
6. Adequate ballast added to front of tractor.

## MAIN FRAME HEIGHT:

Without gauge wheels, set the tractor rockshaft control lever to obtain the desired frame height.

With frame gauge wheels, put the rockshaft control lever all the way forward to lock “it” in the float position, which will enable the frame gauge wheels to maintain the frame at a uniform height from the ground.

## LEVELING MAIN FRAME

Adjust lift links and center link as necessary to make frame level and perpendicular to the ground.

Before activating/folding hinge check for obstructions, especially check gauge wheel positions to ascertain proper tractor and cab clearance.

NOTE: If gauge wheels are to be used, make leveling adjustments after gauge wheels are installed.

## CLOSED CENTER HYDRAULIC SYSTEM

Wing fold hydraulic valve must be in float position to allow the wings to “**flex**” up and down while operating in the field.

Wing fold hydraulic valve must be in neutral position to hold the wings “**rigid**” while operating in the field.



**CAUTION: ALWAYS FOLLOW ALL STATE, FEDERAL, AND LOCAL LAWS WHEN TRANSPORTING 3800 TOOLBAR ON PUBLIC ROADS.**

# PARTS IDENTIFICATION DECALS

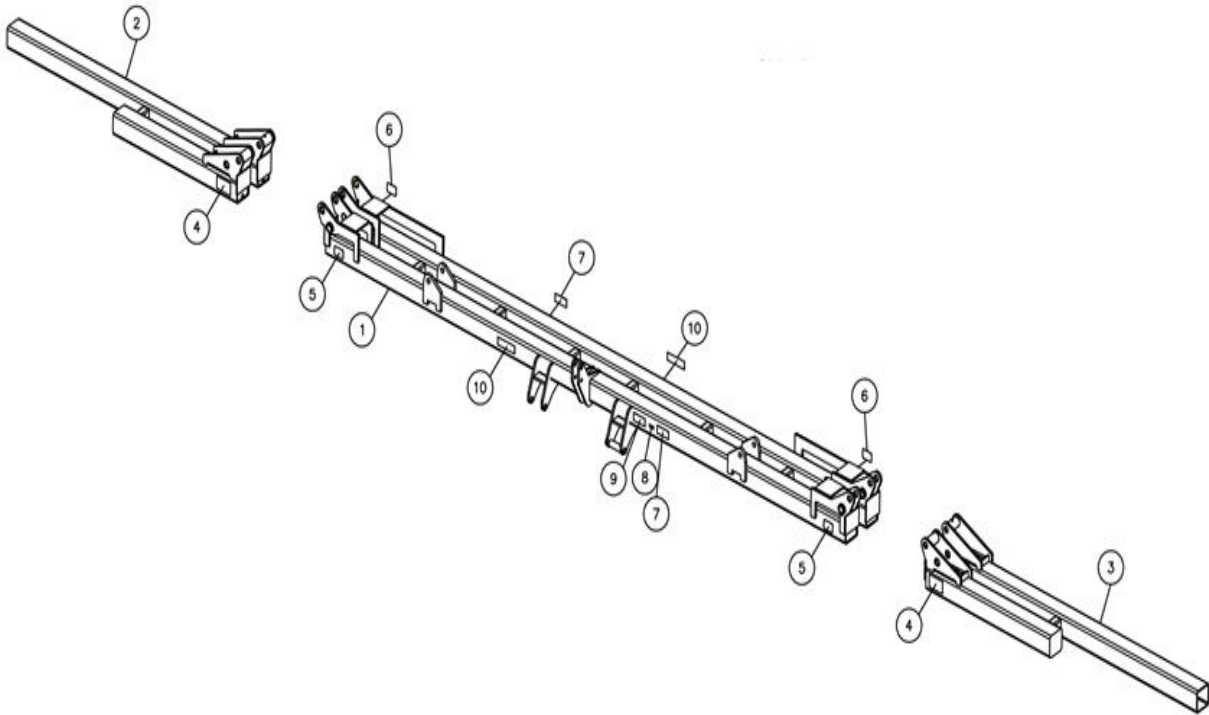

ITEM	QTY	PART NO.	DESCRIPTION
1	1	3831-200	31' CENTER SECTION
	1	3841-200	41' CENTER SECTION
2	1	3831-202	31' RH WING
	1	3841-201	41' RH WING
3	1	3831-201	31' LH WING
	1	3841-202	41' LH WING
4	2	2565-159	FOLDING WING CAUTION DECAL
5	2	2565-803	AMBER REFLECTOR
6	2	2565-804	RED REFLECTOR
7	2	2565-087	3831 DECAL
	2	2565-086	3841 DECAL
8	1	2565-466	PRODUCT ID PLATE
9	1	2565-163	PARKING DECAL
10	2	2565-058	YETTER EQUIPMENT DECAL

# PARTS IDENTIFICATION

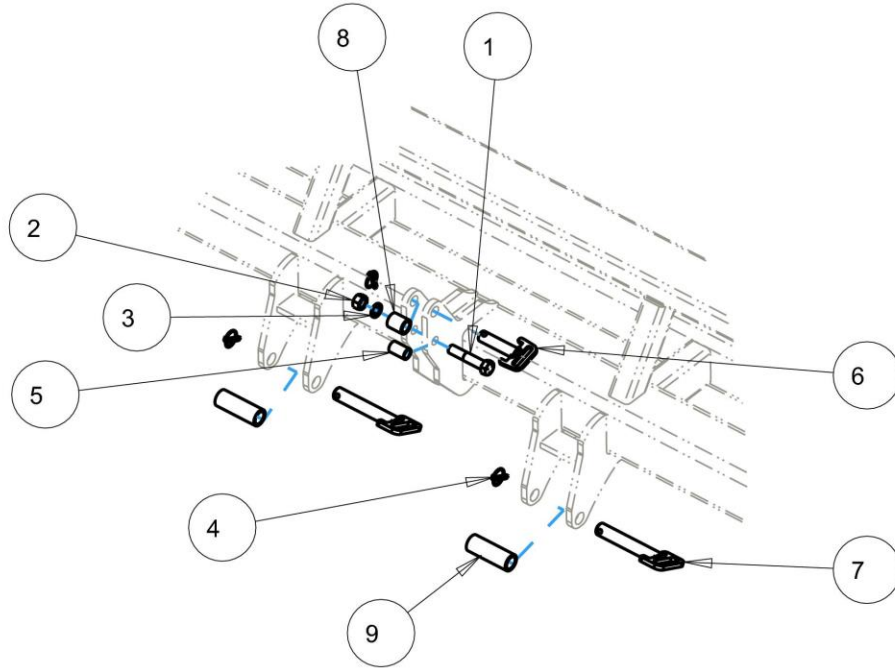

ITEM	PART NO.	DESCRIPTION	QTY
1	2502-770	1-8 X 5 HHCS GR. 5 ZP	1
2	2520-555	1-8 HEX NUT ZP	1
3	2525-550	1" MED. LOCKWASHER ZP.	1
4	2570-454	KLIK PIN DANUSER #7524	3
5	3400-312	UPPER HITCH PIPE	1
6	3560-206	UPPER HITCH PIN W.A., HD	1
7	3560-207	LOWER HITCH PIN W.A., HD	2
8	3560-303	60' UPPER HITCH BUSHING, ZP	1
9	3560-304	60' BUSHING (LONG), ZP	2

ISO3554-104

# PARTS IDENTIFICATION

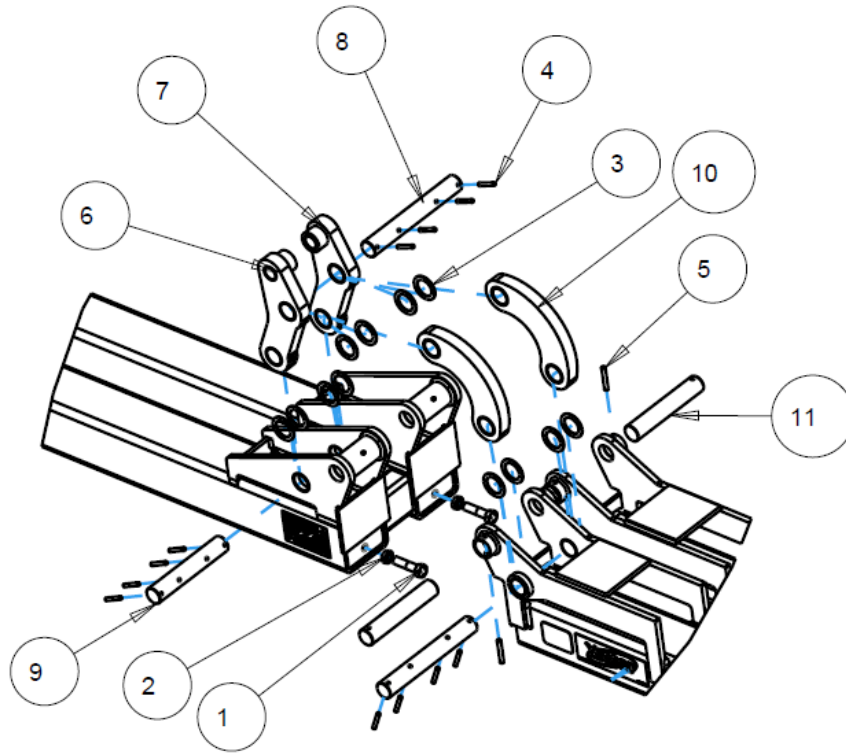

ITEM	QTY	PART NO.	DESCRIPTION
1	4	2502-604	7/8"-9 X 3-1/2 CAP SCREW GR. 2
2	4	2520-543	7/8"-9 JAM HEX NUT
3	24	2527-567	2" WASHER
4	24	2530-208	3/8" X 2-1/2" ROLL PIN
5	4	2530-221	7/16" X 3 ROLL PIN
6	2	3841-204	LH CYLINDER LINK ASSEMBLY
	1	3841-316	LINER 1.0567" ID X 1.75" OD X 3" W
	2	3841-313	LINER 2.0071" ID X 2.25" OD X 1.5" W
7	2	3841-205	RH CYLINDER LINK ASSEMBLY
	1	3841-316	LINER 1.0567" ID X 1.75" OD X 3" W
	2	3841-313	LINER 2.0071" ID X 2.25" OD X 1.5" W
8	4	3841-304	LINK PIN, LONG 14.813"
9	2	3841-305	LINK PIN, SHORT 11.625"
10	4	3841-306	SHORT LINKAGE ASSEMBLY
	2	3841-313	LINER 2.0071" ID X 2.25" OD X 1.5" W
11	4	3841-330	LINK PIN, UPPER 11.162"

MANUFACTURED 01-2021 TO PRESENT

# PARTS IDENTIFICATION

## 3800 HINGE ASSEMBLY

DET	QTY	PART NO.	DESCRIPTION
1	1	3831-207	31" CENTER SECTION
	4	3841-313	LINER, LINK BASE
	8	3841-324	LINER, HINGE PLATE
1	1	3841-216	41" CENTER SECTION
	4	3841-313	LINER, LINK BASE
	8	3841-324	LINER, HINGE PLATE
2	2	3841-303	HINGE PIN
3	2	3841-154	SHORT LINK ASSEMBLY
	1	3841-306	SHORT LINK
	2	3841-313	LINER, LINK BASE
4	4	3841-304	LINK PIN, LONG 14.813"
5	2	3841-205	CYLINDER LINK RIGHT HAND
	2	3841-313	LINER, LINK BASE
	1	3841-316	LINER, ROD END
6	2	3841-204	CYLINDER LINK LEFT HAND
	2	3841-313	LINER, LINK BASE
	1	3841-316	LINER, LINK BASE
7	1	3831-201	L.H. WING
	2	3841-324	LINER, HINGE PLATE
	1	3831-202	R.H. WING (SHOWN)
	2	3841-324	LINER, HINGE PLATE
	1	3841-218	R.H. WING (SHOWN)
	2	3841-324	LINER, HINGE PLATE
	1	3841-217	L.H. WING
	2	3841-324	LINER, HINGE PLATE
	1	3841-316	LINER, ROD END
8	12	2530-208	3/8 X 2-1/2 ROLL PIN ZP
9	12	2527-567	2" WASHER
10	2	3841-305	LINK PIN, SHORT 11.625"
11	4	2502-604	7/8 9X31-1THD HD TPBLT G2Z
12	4	2520-543	7/8 -9 JAM HEX NUT ZP
13	2	2520-515	3/4-10 LOCK HEX NUT ZP
14	2	2502-404	3/4-10 X 4 HHCS GR. 5 ZP
15	2	3841-340	RETAINING COLLAR
16	4	2503-201	1/4-20 X 1/2 SET SCREW

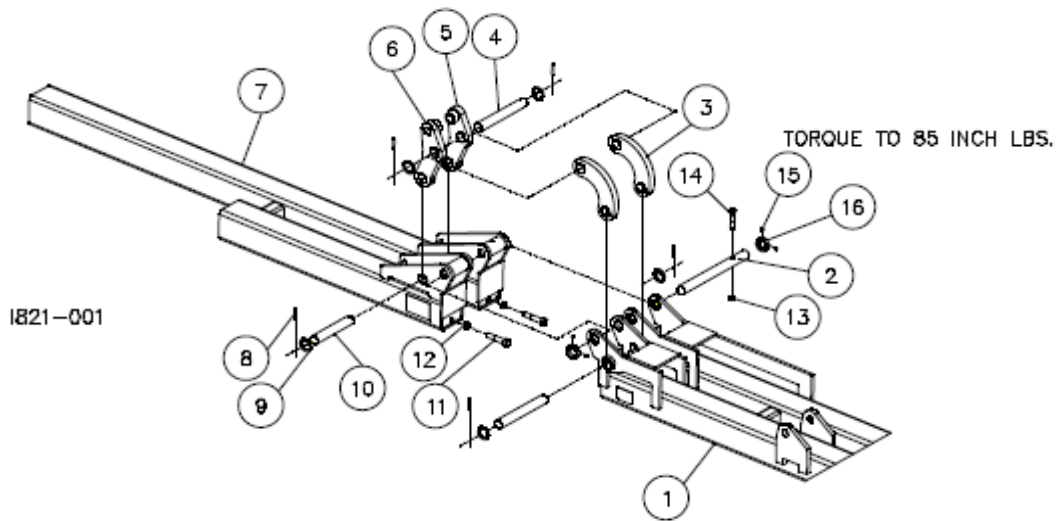

MANUFACTURED 07-2012 TO 12-2020

# PARTS IDENTIFICATION

## PARKING STAND ASSEMBLY

DET	QTY	PART NO.	DESCRIPTION
1	2	3841-211	HD STAND BRACKET W.A.
2	4	2570-478	3/4 X 7 X 9 U-BOLT, ZP
3	8	2520-515	3/4-10 LOCK HEX NUT ZP
4	2	3500-333	STAND PIN, ZP
5	2	2570-465	7 GA. HAIRPIN COTTER ZP
6	2	3841-212	HD STAND W.A.

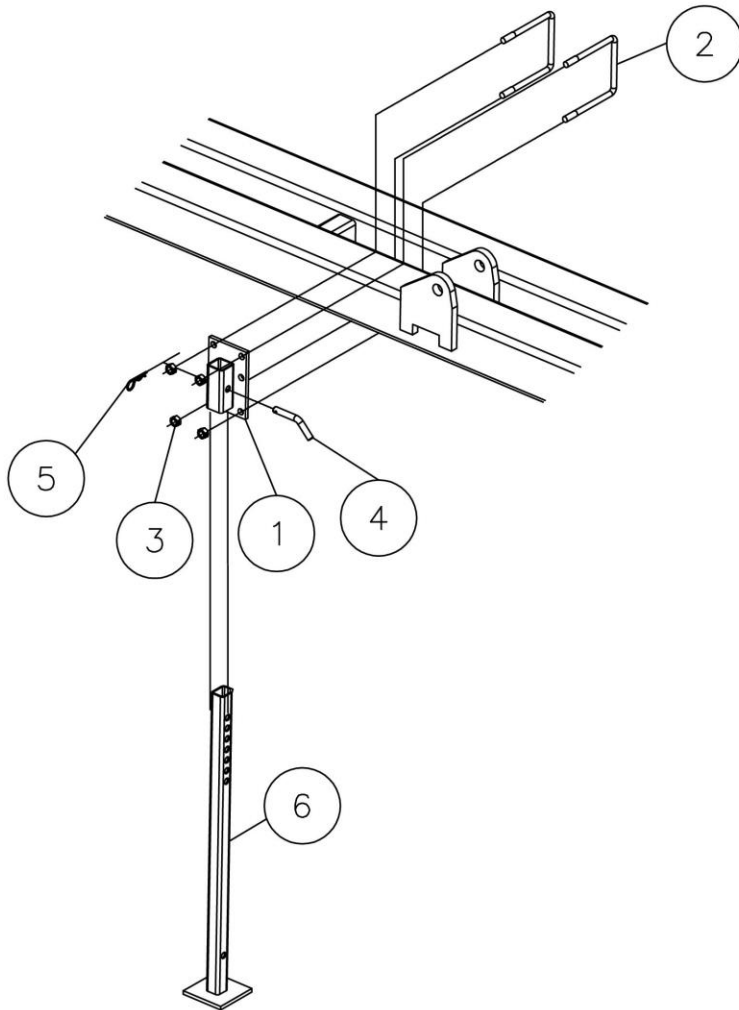



# PARTS IDENTIFICATION

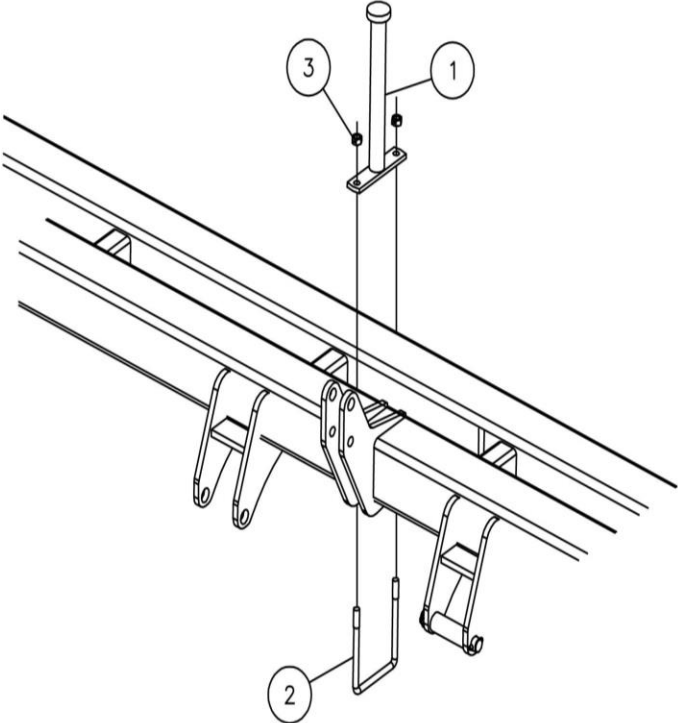

ITEM	QTY.	PART NO.	DESCRIPTION
1	2	3841-219	WING REST
2	2	2570-478	3/4" X 7" X 9" U-BOLT
3	2	2520-515	3/4" LOCK HEX NUT

# PARTS IDENTIFICATION

## OPTIONAL

3800-114

WING STAND ASSEMBLY

ITEM	PART NO.	DESCRIPTION	QTY
1	1300-507	RUBBER FOOT	1
2	2502-404	3/4-10 X 4 HHCS GR 5 ZP	2
3	2520-504	3/4-10 HEX NUT ZP	4
4	2520-515	3/4-10 LOCK HEX NUT ZP	2
5	2525-501	3/4 MED. LOCKWASHER ZP.	4
6	2570-478	3/4 X 7 X 9 U-BOLT, ZP	2
7	8000-231	TOOLBAR REST BASE W.A.	1
8	8000-232	TOOLBAR REST EXTENSION W.A.	1

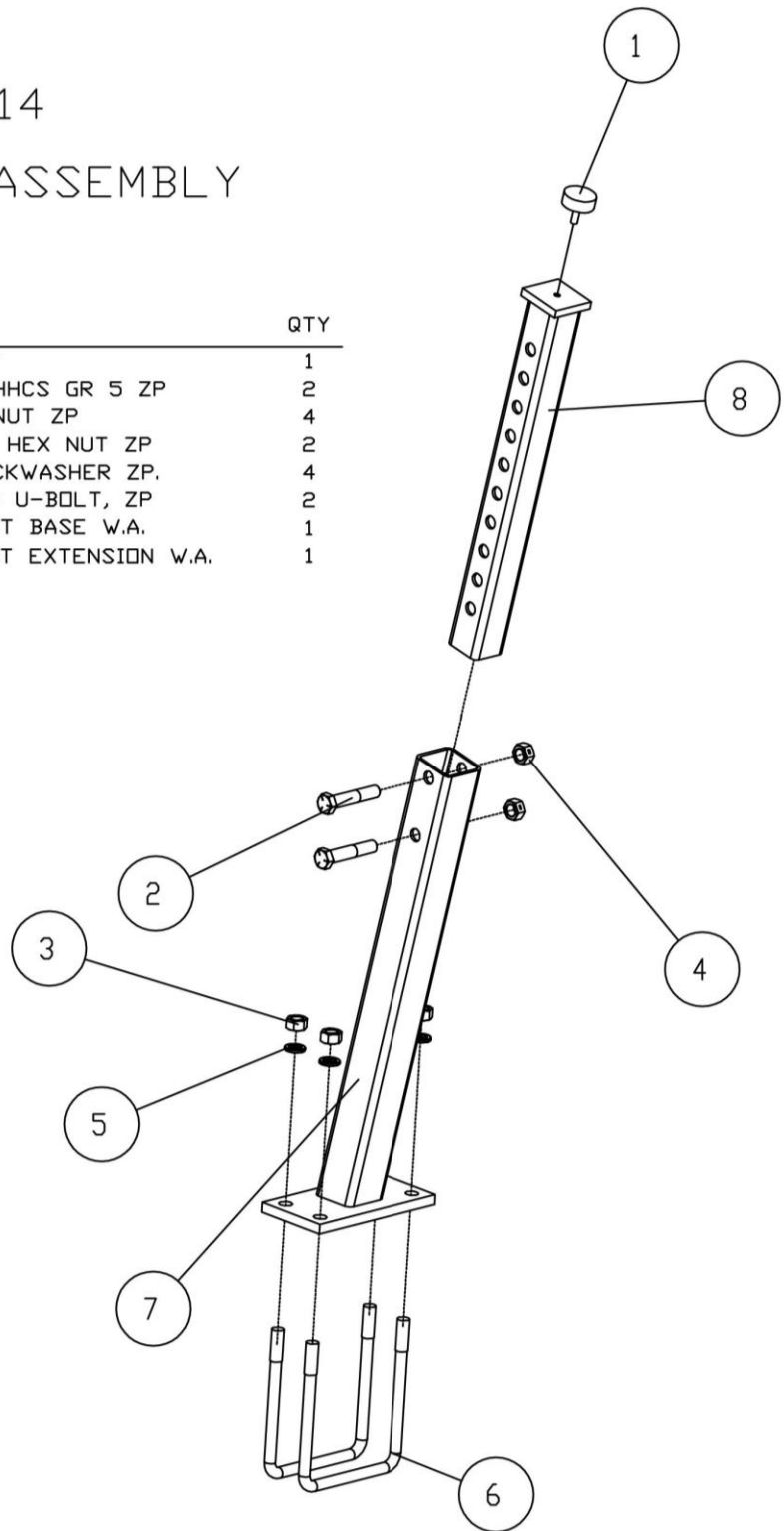

# PARTS IDENTIFICATION

3500-113

ITEM	PART NO.	DESCRIPTION	QTY
1	2502-313	1/2-13 X 3 HHCS GR 5 ZP	1
2	2502-765	1"-8 X 7 HHCS GR8 ZN	2
3	2520-357	1/2-13 LOCK HEX NUT ZP	1
4	2520-360	1/2-20 WHEEL HEX NUT	5
5	2520-555	1-8 HEX NUT ZP	2
6	2520-562	1-8 LOCK HEX NUT ZP	2
7	2570-323	15 X 5 KB WHEEL, SAE #554	1
8	2570-485	1 x 7 x 9 U-BOLT, ZP	1
9	3400-374	HUB & SPINDLE	1
10	3500-236	GAUGE WHEEL ARM W.A.	1
11	3500-237	UNDERBAR MOUNT W.A.	1
12	3500-409	RATCHET JACK	1

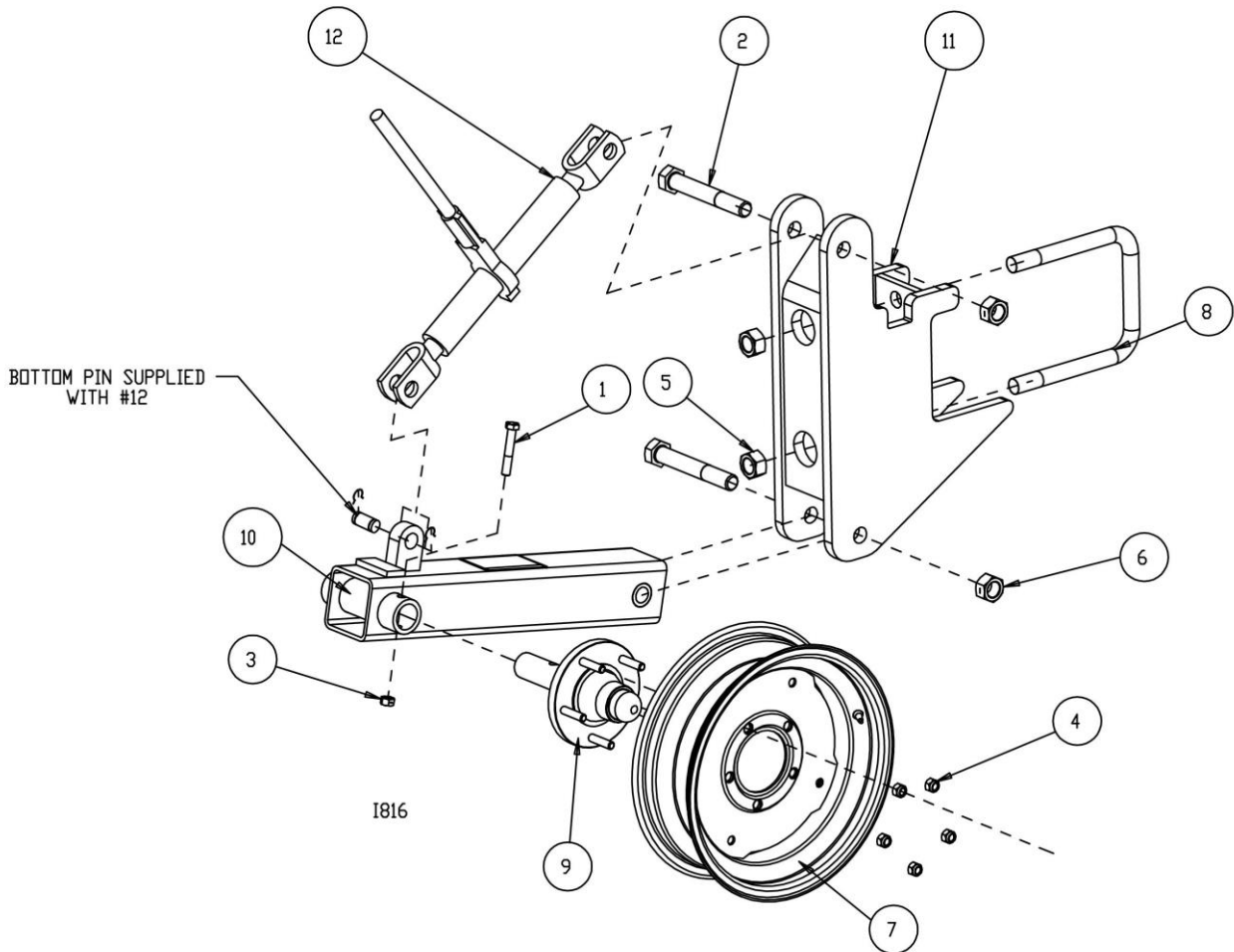

# PARTS IDENTIFICATION

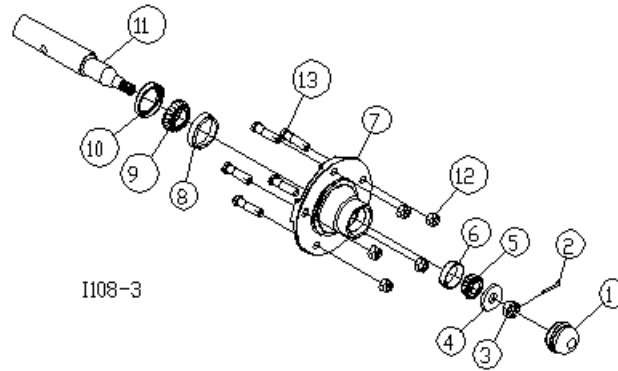

I108-3

## 3400-374 HUB AND SPINDLE ASSEMBLY

DET	QTY	PART NO.	DESCRIPTION
1	1	2570-308	HUB CAP
2	1	2531-108	5/32 X 1-1/4 COTTER PIN
3	1	2520-469	5/8-18 SLOTTED HEX NUT
4	1	2526-449	5/8 SAE FLATWASHER
5	1	2550-012	CONE (LM-11949)
6	1	2550-013	CUP (LM-11910)
7	1	HUB	4*PILOT 5-1/2" BOLT CIRCLE (NOT A SERVICE PART)
8	1	2550-029	CUP (LM-67010)
9	1	2550-027	CONE (LM-67048)
10	1	2550-115	SEAL (104078)
11	1	3400-378	SPINDLE, 2570-310
12	5	2520-360	1/2-20 WHEEL HEX NUT
13	5	2570-190	1/2-20 X 1.90" HUB BOLT

REVISED 09/09/2020

# PARTS IDENTIFICATION

## 3800-110 HITCH KIT

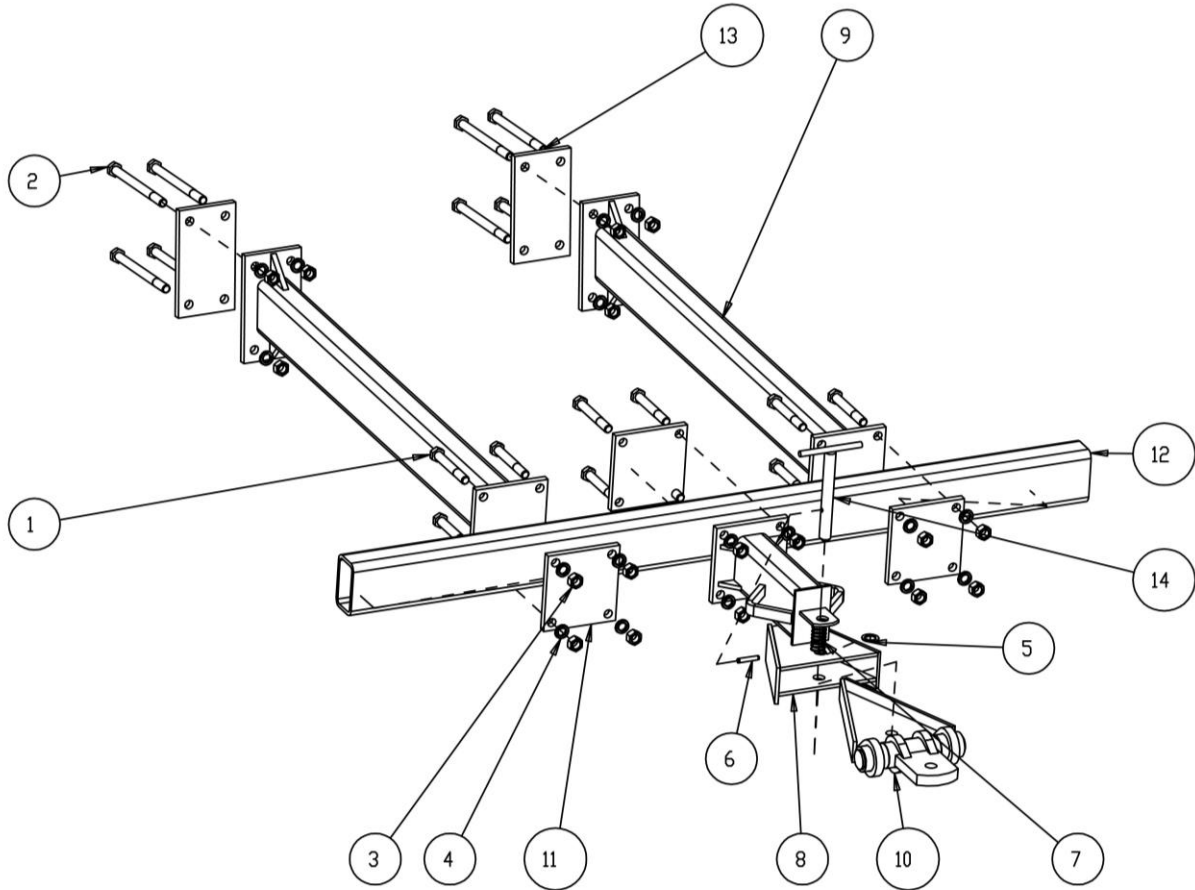

ITEM	PART NO.	DESCRIPTION	QTY
1	2502-508	3/4-10 X 5-1/2 HHCS GR5ZYD	12
2	2502-516	3/4-10 X 9-1/2 HHCS GR5 ZP	8
3	2520-504	3/4-10 HEX NUT ZP	20
4	2525-501	3/4 MED. LOCKWASHER ZP.	20
5	2527-550	1"ID X1-1/2OD X14GA MACH	1
6	2530-212	3/8 X 2 ROLL PIN ZP	1
7	2550-761	THROW OUT CLUTCH SPRING, BLACK	1
8	3800-200	REAR HITCH W.A.	1
9	3800-201	HITCH EXTENSION W.A.	2
10	3800-204	PULLRING ASSEMBLY W.A.	1
11	3800-300	MDUNT PLATE	3
12	3800-302	72" CROSS TUBE	1
13	3800-312	HITCH MOUNT PLATE	2
14	8000-220	HITCH PIN	1

# PARTS IDENTIFICATION 3831 TOOLBAR ASSEMBLY

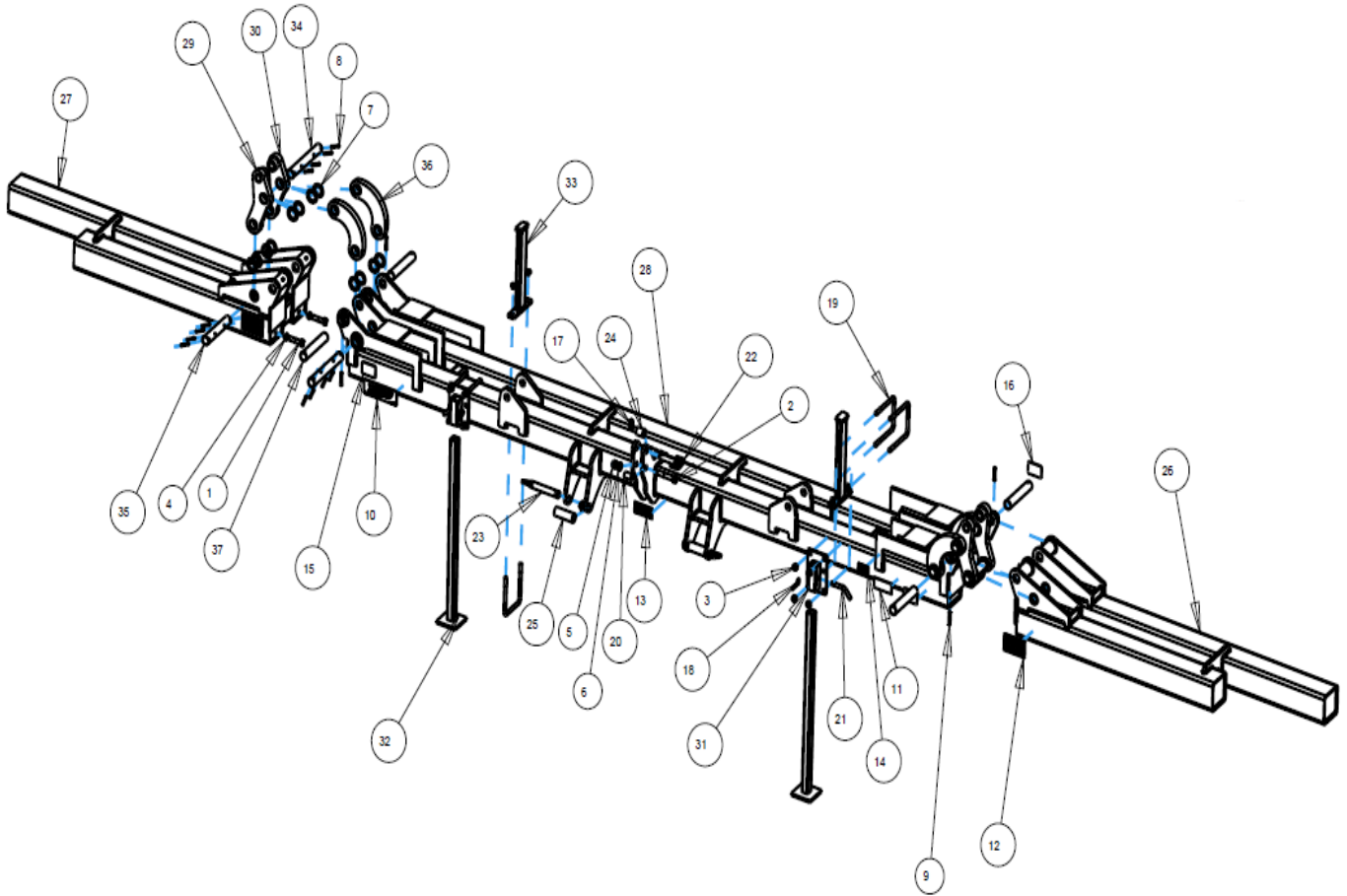

ISO3831-171-2

## PARTS IDENTIFICATION 3831 TOOLBAR ASSEMBLY

ITEM	PART NO.	DESCRIPTION	QTY
1	2502-604	7/8 - 9 X 3-1/2 HHCS. GR 2, ZP	4
2	2502-770	1-8 X 5 HHCS GR. 5 ZP	1
3	2520-515	3/4-10 LOCK HEX NUT, GR A, ZP	12
4	2520-543	7/8-9 JAM HEX NUT ZP	4
5	2520-555	1-8 HEX NUT ZP	1
6	2525-550	1" MED. LOCKWASHER ZP.	1
7	2527-567	2" WASHER	24
8	2530-208	3/8 X 2-1/2 ROLL PIN ZP	24
9	2530-221	7/16 X 3 ROLL PIN ZP	4
10	2565-058	YET FRM EQUI DE 3-7/16X10-5/16	2
11	2565-087	3831 DECAL	2
12	2565-159	FOLDING WING CAUTION DECAL	2
13	2565-163	PARKING DECAL	1
14	2565-466	PRODUCT ID PLATE	1
15	2565-803	AMBER REFLECTOR 2.91 X 4.3	2
16	2565-804	RED REFLECTOR 2.91 X 4.3	2
17	2570-454	KLIK PIN DANUSER #7524	3
18	2570-465	7 GA. HAIRPIN COTTER ZP	2
19	2570-478	3/4 X 7 X 9 U-BOLT, ZP	6
20	3400-312	UPPER HITCH PIPE	1
21	3500-333	STAND PIN, ZP	2
22	3560-206	UPPER HITCH PIN W.A., HD	1
23	3560-207	LOWER HITCH PIN W.A., HD	2
24	3560-303	60' UPPER HITCH BUSHING, ZP	1
25	3560-304	60' BUSHING (LONG), ZP	2
26	3831-201	LH WING W.A.	1
27	3831-202	RH WING W.A.	1
28	3831-207	31' CENTER SECTION W.A.	1
29	3841-204	CYLINDER LINKAGE W.A., LH	2
30	3841-205	CLYINDER LINKAGE W.A., RH	2
31	3841-211	HD STAND BRACKET W.A.	2
32	3841-212	HD STAND W.A.	2
33	3841-219	WING REST W.A.	2
34	3841-304	LINK PIN, LONG	4
35	3841-305	LINK PIN, SHORT	2
36	3841-306	SHORT LINKAGE ASSEMBLY	4
37	3841-330	LINK PIN, UPPER	4

# PARTS IDENTIFICATION 3841 TOOLBAR ASSEMBLY

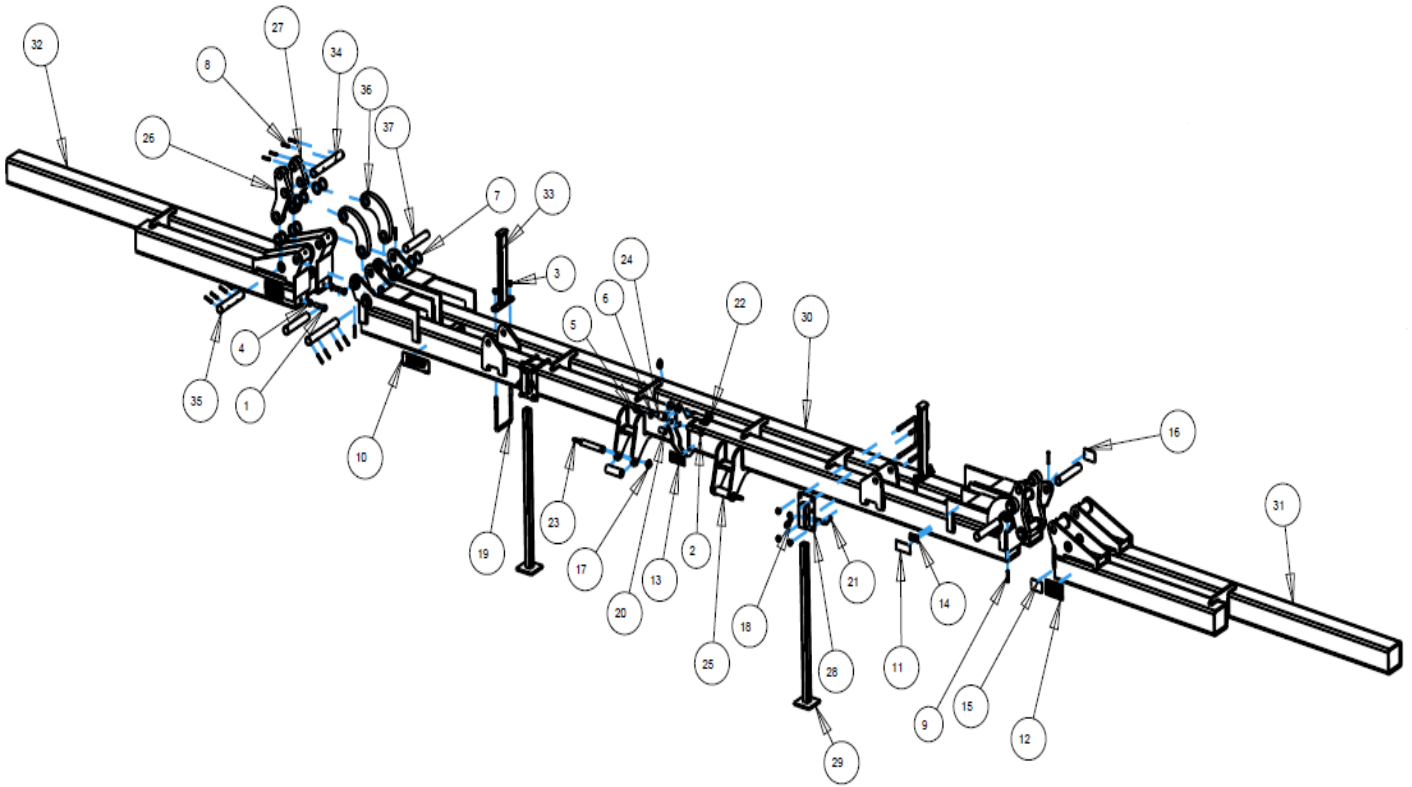

ISO3841-171-2



## PARTS IDENTIFICATION 3841 TOOLBAR ASSEMBLY

ITEM	PART NO.	DESCRIPTION	QTY
1	2502-604	7/8 - 9 X 3-1/2 HHCS. GR 2, ZP	4
2	2502-770	1-8 X 5 HHCS GR. 5 ZP	1
3	2520-515	3/4-10 LOCK HEX NUT, GR A, ZP	12
4	2520-543	7/8-9 JAM HEX NUT ZP	4
5	2520-555	1-8 HEX NUT ZP	1
6	2525-550	1" MED. LOCKWASHER ZP.	1
7	2527-567	2" WASHER	24
8	2530-208	3/8 X 2-1/2 ROLL PIN ZP	24
9	2530-221	7/16 X 3 ROLL PIN ZP	4
10	2565-058	YET FRM EQUI DE 3-7/16X10-5/16	2
11	2565-086	41' DECAL	2
12	2565-159	FOLDING WING CAUTION DECAL	2
13	2565-163	PARKING DECAL	1
14	2565-466	PRODUCT ID PLATE	1
15	2565-803	AMBER REFLECTOR 2.91 X 4.3	2
16	2565-804	RED REFLECTOR 2.91 X 4.3	2
17	2570-454	KLIK PIN DANUSER #7524	3
18	2570-465	7 GA. HAIRPIN COTTER ZP	2
19	2570-478	3/4 X 7 X 9 U-BOLT, ZP	6
20	3400-312	UPPER HITCH PIPE	1
21	3500-333	STAND PIN, ZP	2
22	3560-206	UPPER HITCH PIN W.A., HD	1
23	3560-207	LOWER HITCH PIN W.A., HD	2
24	3560-303	60' UPPER HITCH BUSHING, ZP	1
25	3560-304	60' BUSHING (LONG), ZP	2
26	3841-204	CYLINDER LINKAGE W.A., LH	2
27	3841-205	CLYINDER LINKAGE W.A., RH	2
28	3841-211	HD STAND BRACKET W.A.	2
29	3841-212	HD STAND W.A.	2
30	3841-216	41' CENTER SECTION W.A.	1
31	3841-217	LH WING W.A.	1
32	3841-218	RH WING W.A.	1
33	3841-219	WING REST W.A.	2
34	3841-304	LINK PIN, LONG	4
35	3841-305	LINK PIN, SHORT	2
36	3841-306	SHORT LINKAGE ASSEMBLY	4
37	3841-330	LINK PIN, UPPER	4

## PARTS IDENTIFICATION

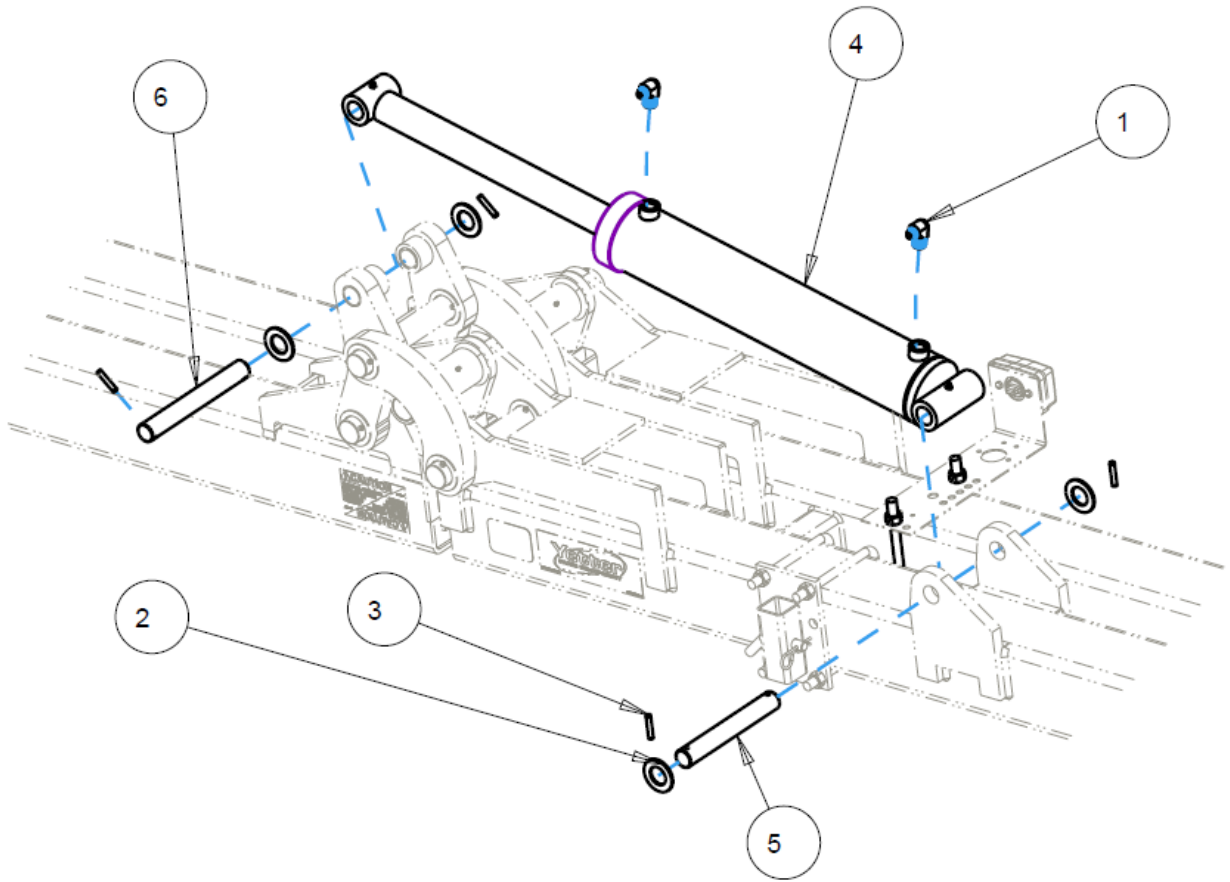

ITEM	PART NO.	DESCRIPTION	QTY
1	2515-830	2501-06-12 90 DEG. FITTING (RESTRICTED)	4
2	2527-566	1.5" TYPE B NARROW WASHER	8
3	2530-212	3/8 X 2 ROLL PIN ZP	8
4	3841-300	5 X 24 HD WELDED HYDRAULIC CYLINDER	2
5	3841-301	CYLINDER PIN, BASE END	2
6	3841-302	CYLINDER PIN, ROD END	2

# TROUBLE SHOOTING

Problem	Cause	Solution
Hydraulic cylinders fail to operate properly	Hydraulic system improperly installed Air in system Blocked restrictors	Check for correct assembly of the hydraulic system Check for air in the hydraulic system and purge system Check restrictors for malfunctions



A Tradition of Solutions since 1930

Yetter Farm Equipment Co

PO BOX 358 109 S. McDonough

Colchester, IL 62326-0358

Phone: 309-776-4111

Toll Free: 800-447-5777

Email: [info@yetterco.com](mailto:info@yetterco.com)

For updated models and manuals visit the Yetter website:

[www.yetterco.com](http://www.yetterco.com)

© Yetter Farm Equipment Co. All Rights Reserved

2565-772\_REV\_H • 07/2021