



**2960 SERIES II**

**UNIT MOUNTED  
CONSERVATION  
COULTER**

**YETTER MANUFACTURING CO.**

*FOUNDED 1930*

Colchester, IL 62326-0358

Toll free: 800/447-5777

309/776-3222 (Fax)

Website: [www.yetterco.com](http://www.yetterco.com)

E-mail: [info@yetterco.com](mailto:info@yetterco.com)

**YETTER**

## FOREWORD

You've just joined an exclusive but rapidly growing club.

For our part, we want to welcome you to the group and thank you for buying a Yetter Product.

We hope your new Yetter products will help you achieve both increased productivity and increased efficiency so that you may generate more profit. This operator's manual has been designed into six major sections.

Foreword, Safety Precautions, assembly instructions, Operation, parts identification and troubleshooting.

Throughout the manual references may be made to left side and right side. These terms are used as viewed from the operator's seat facing the front of the tractor.



This **SAFETY ALERT SYMBOL** indicates important safety messages in the manual. When you see this symbol, be alert to the possibility of **PERSONAL INJURY** and carefully read the message that follows.

The word **NOTE** is used to convey information that is out of context with the manual text. It contains special information such as specifications, techniques, reference information and other information of a supplementary nature.

The word **IMPORTANT** is used in the text when immediate damage will occur to the machine due to improper technique or operation. Important will apply to the same information as specified by note only of an immediate and urgent nature.

It is the responsibility of the user to read the operator's manual and comply with the safe and correct operating procedure and to lubricate and maintain the product according to the maintenance schedule in the operator's manual.

The user is responsible for inspecting his machine and for having parts repaired or replaced when continued use of the product would cause damage or excessive wear to the other parts.

It is the user's responsibility to deliver his machine to the Yetter dealer who sold him the product for service or replacement of defective parts that are covered by the warranty policy.

If you are unable to understand or follow the instructions provided in the publication, consult you local Yetter dealer or contact:

### YETTER MANUFACTURING CO.

309/776-4111

800/447-5777

309/776-3222 (FAX)

Website: [www.yetterco.com](http://www.yetterco.com)

E-mail: [info@yetterco.com](mailto:info@yetterco.com)

## WARRANTY POLICY

Yetter Manufacturing warrants all products manufactured and sold by it against defects in material. This warranty being expressly limited to replacement at the factory of such parts or products as will appear to be defective after inspection. This warranty does not obligate the Company to bear cost of labor in replacement of parts. It is the policy of the company to make improvements without incurring obligations to add them to any unit already sold. No warranty is made or authorized to be made, other than herein set forth. This warranty is in effect for one year after purchase.

Model Number: \_\_\_\_\_

Dealer : \_\_\_\_\_

**Yetter Manufacturing warrants its own products only and cannot be responsible for damage to equipment on which mounted.**

# SAFETY

**A brief description of signal words that may be used in this manual.**

**CAUTION:** Used as a general reminder of good safety practices or to direct attention to unsafe practices.

**WARNING:** Denotes a specific potential hazard.

**DANGER:** Denotes the most serious specific potential hazard.

## SAFETY PRECAUTIONS

You can make your farm a safer place to live and work if you observe the safety precautions given. Study these precautions carefully and insist that they be followed by those working with you and for you.

Finally, remember this: an accident is usually caused by someone's carelessness, neglect or oversight.



### WARNING

Never clean, lubricate or adjust a machine that is in motion. Always install the transport lock pins and bracket when transporting for any length of time or on public roadways.

If required to service unit in raised position, be sure to install all transport lock pins and locking bracket.

Do not allow children to operate this equipment.

Do not allow riders on the tractor or implement.

Use speeds and caution dictated by the terrain being traversed. Do not operate on any slope steep enough to cause tipping or loss of control.

Be sure all personnel are clear of the immediate area before operating.

Read and understand the operator's manual and require all other persons who will operate the equipment to do the same.

In operating on public roadways, where legal, be certain all lighting is operating properly and observe all traffic laws. Ensure slow moving vehicle emblem on tractor is visible.

Beware of increased stopping distances and control effort when operating with implements attached.

Be familiar with all tractor and implement controls and be prepared to stop engine and implements quickly in an emergency.



### CAUTION

Consult your implement and tractor's operator's manual for correct and safe operating practices.

**FAILURE TO HEED MAY RESULT IN PERSONAL INJURY OR DEATH.**

# OPERATION PRECAUTIONS

## STOP

Read this before using the Yetter product.

### - MACHINE OPERATION

**IMPORTANT:** failure to properly set the planter frame height and levelness can result in less than successful operation of the planter and the Yetter product and may result in damaged equipment. All operators should read and thoroughly understand the instructions given prior to using the Yetter product.

NOTE: **DO NOT** use this product if the planter is not adjusted properly!

Leveling the planter:

With the planter lowered to proper operating height (**Usually 20"-22"**).

**Read the planter operator's manual for recommended setting.** Check to be sure the toolbar and row unit parallel arms are level fore and aft. **Re-check** when the planter is in the **field** and has been **fully loaded** with seed, fertilizer, granular chemicals, etc. Also, a field check with a bubble level on the frame should be made of the hitch height to ensure level operation front to back.

It is important for the planter to operate level laterally. Tire pressure must be maintained at pressures specified by the manufacturer.

Field and actual planting conditions change and will dictate planter frame heights. You must ensure that the row unit parallel arms are approximately parallel with the ground.

**IMPORTANT:** For proper operation of the planter attachments and row units, it is imperative that the planter toolbars and row unit parallel arms be level side-to-side and front-to-rear. The toolbar frame should operate at a 20"-22" height from the **planting surface**. Check the manufacturer's operator's manual for instructions on how to adjust the frame height and levelness.

# PLANTER ADJUSTMENT

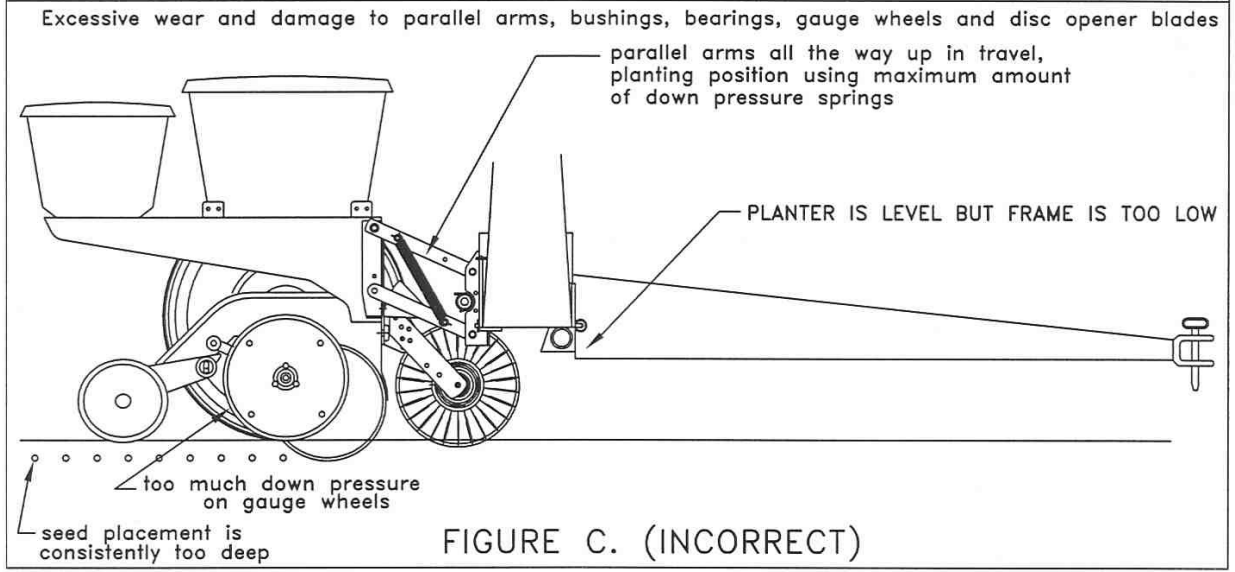
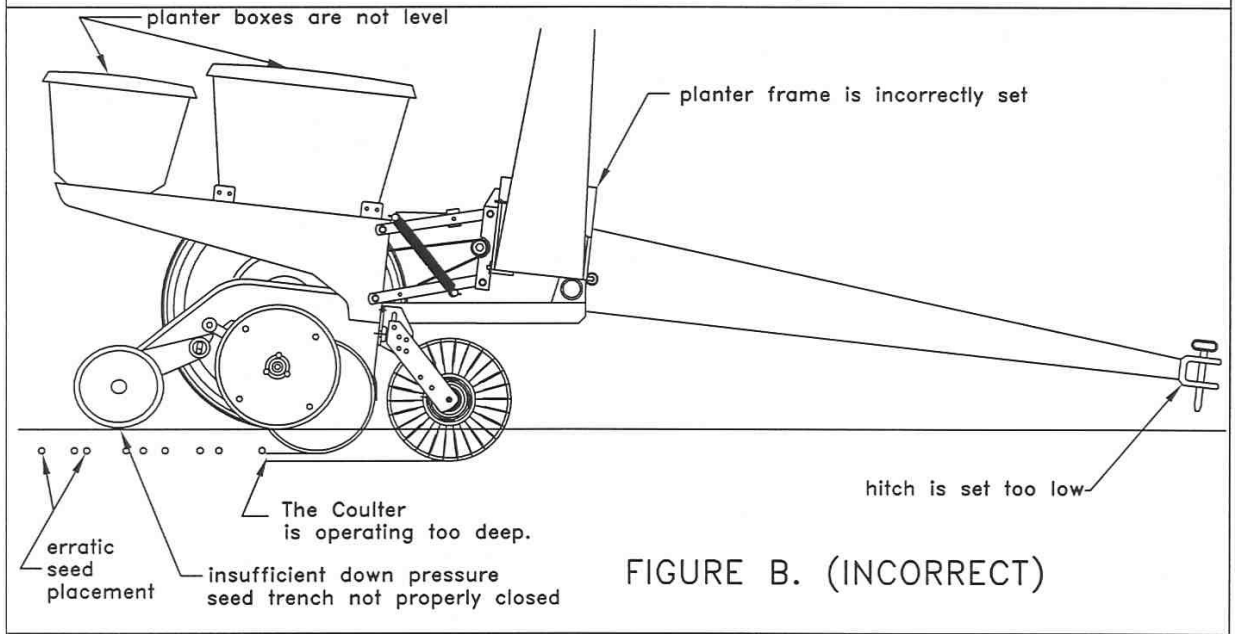
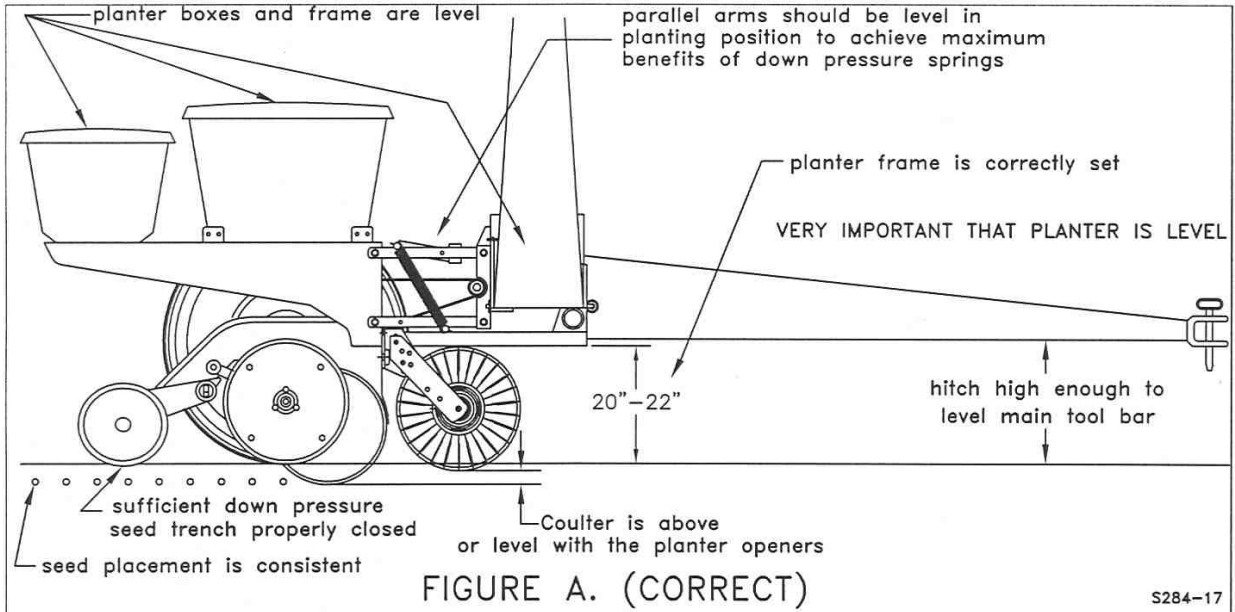

## INTRODUCTION

The 2960 Series II Unit Mounted Conservation Coulter has been designed as a 'universal' fitment for several makes of planter units.

By using two different arrangements of the same parts, the one boxed unit will fit several planters. One arrangement will fit the John Deere MaxEmerge 2 and plus type planters. Another arrangement of the same part will fit the old style 7000 John Deere units and Kinze units; and the coulter only will fit the 9000 Series New Idea and White 6100 units. The coulter is available separately as 2960-127, the spring kit is available separately as 2960-126 or the coulter and spring kit can be ordered as a kit 2960-015. Various different styles and sizes of blades are available to suit particular field conditions, see page 8.

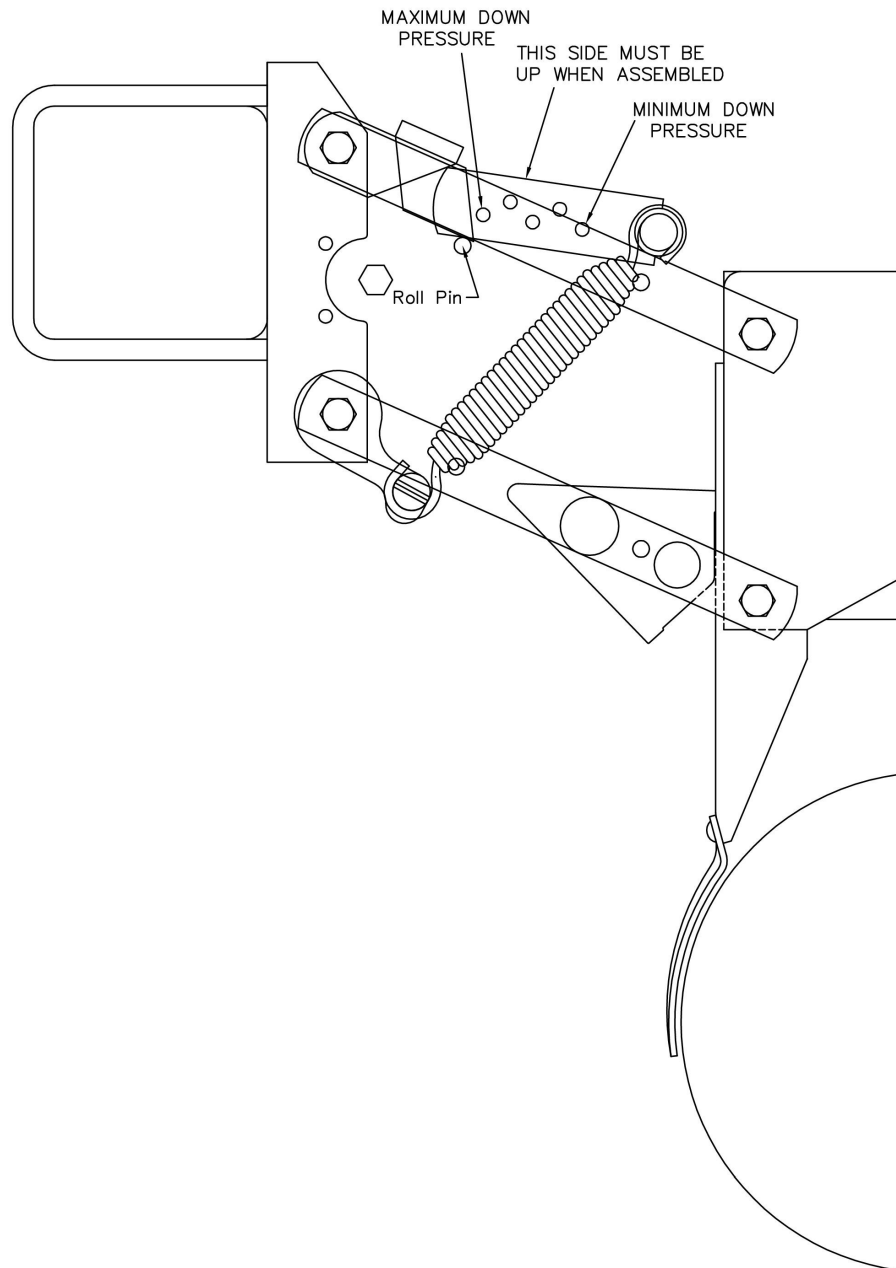

S95

# HEAVY DUTY COULTER INSTALLATION

NOTE: Mounting hardware included in 2960-122 bolt bag.

1. Mount the universal unit coulters bracket to planter breast plate using three  $\frac{1}{2}$ " x  $1\frac{1}{2}$ " bolts, washers and locknuts. Use the  $\frac{1}{4}$ " thick washer on the lower large slot, do not tighten fully yet.

NOTE: The  $\frac{9}{16}$ " dia. round hole is not used on this application, disregard this hole.

2. Mount unit coulters arm to unit coulters bracket using  $\frac{1}{2}$ " x  $2\frac{1}{2}$ " bolt, flat washers and locknut through slots in bracket and upper hole in the arm and  $\frac{1}{2}$ " x  $2$ " bolt and locknut through desired lower holes of bracket and arm.
3. Install blade on hub using four  $\frac{1}{2}$ " x  $1\frac{1}{4}$ " carriage bolts, lock washers and nuts.
4. Align coulters blade with opener blades by sliding bracket on breast plate, then tighten the bolts securing the bracket to the planter unit.
5. Adjust coulters depth as required. **Please note that the minimum depth setting of this coulters on the Deere 7200 and 1700 series planters is even with the opener discs.** As the blade wears, the coulters may be adjusted to compensate.

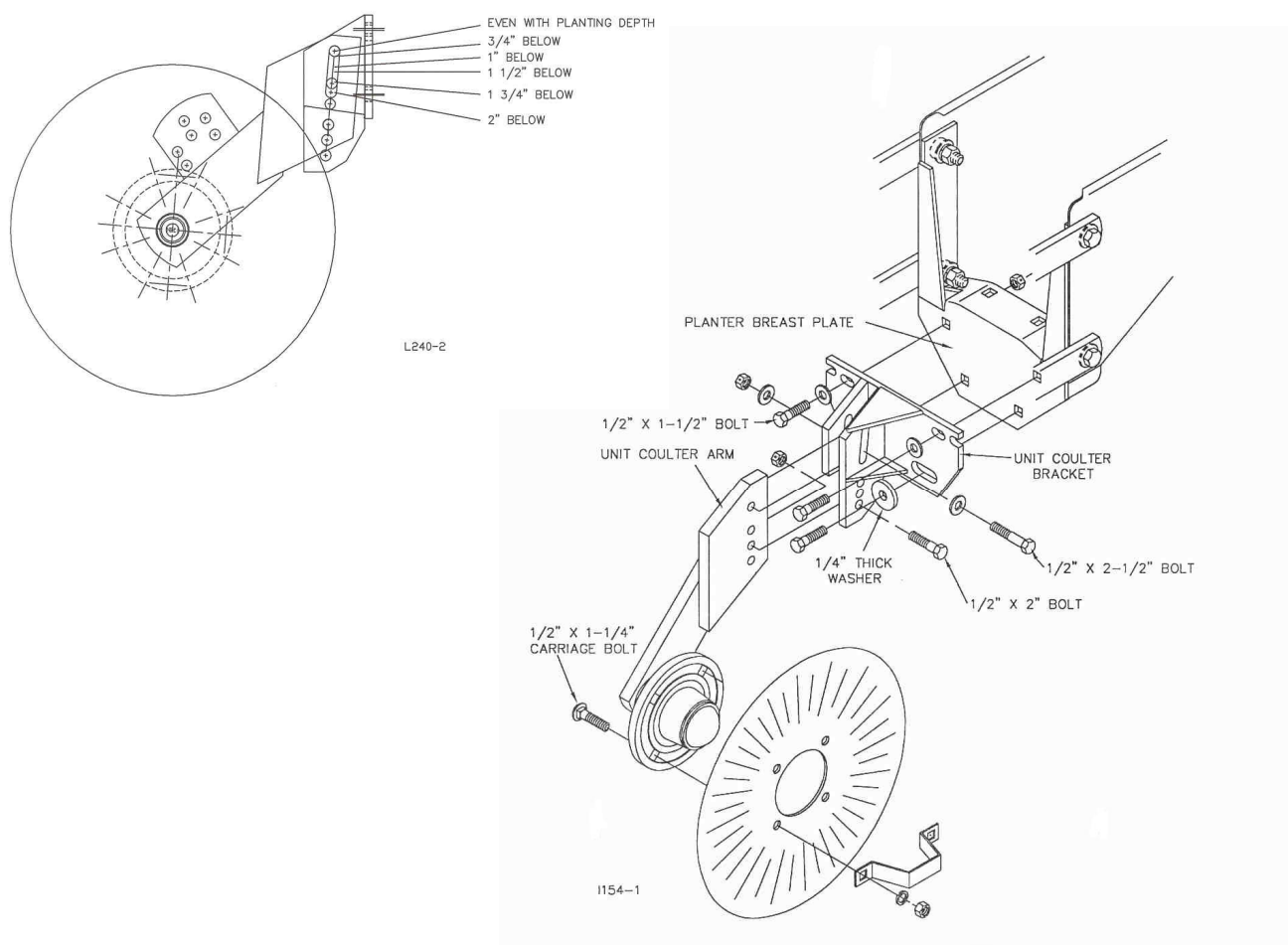

## DOWN PRESSURE SPRING INSTALLATION FOR JOHN DEERE 7000/7200/1700

**NOTE:** Mounting hardware included in 2960-123 bolt bag.

1. Remove the front lower parallel link pivot bolts and spacers. **Do not discard the spacers, as they must be re-used.** Install spring anchor castings to the front lower pivot of the parallel link using new longer bolts and spacers as shown.  
**NOTE:** On John Deere 7000 the short stubs on the castings mount to the outside and the castings mount on the outside of the parallel links, most other planters IE: Yetter & Kinze also assemble as 7000. On John Deere 7200 and 1700 series the short stubs on the castings mount to the inside and the castings mount on the inside of the parallel links.'
2. Remove the front upper parallel link pivot bolts and spacers and install front bar to the upper front of the parallel link using new longer bolts and spacers provided, **along with the existing spacers just disassembled.**
3. Assemble springs and spacers to spring bar as shown in the appropriate drawing and secure with cotter pins.
4. Lower this assembly onto the parallel links with the two middle adjustment holes on the spring bar facing up as shown. This allows maximum down pressure adjustment.
5. Assemble spring bar over the guide pin on the front bar and secure the ends of the springs to the spring anchors using 1/4" x 2" roll pins. It will be necessary to have planter units in transport position to install springs, or adjust tension.
6. Insert spring adjustment pin in the desired hole on the spring bar and secure with 1/8" hairpin cotter.
7. Assemble the spring stops to the upper parallel arms with the 1/2" x 2" bolts and locknuts provided. The spring stops must be assembled on the 'inside' of the arms and the heads must be towards the middle of each row unit. The spring stops are to be assembled to the rear 'spare' hole in the upper parallel arms and will prevent the springs from sliding back too far.
8. Refer to 'Troubleshooting' page if necessary.



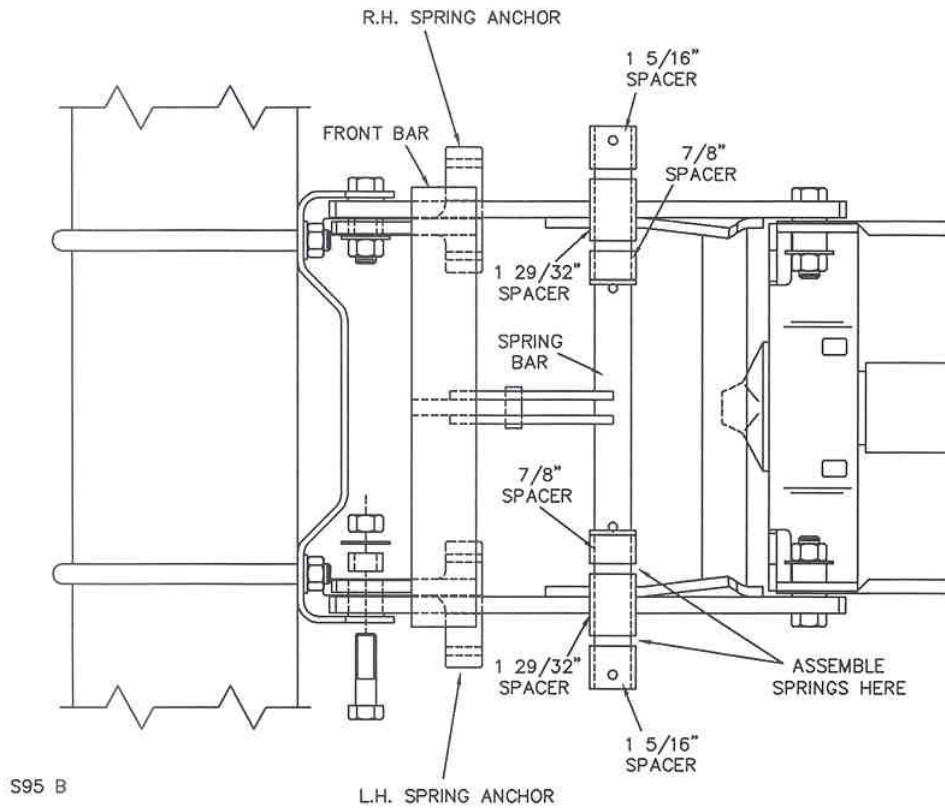

**PARTS ARRANGEMENT FOR J.D. 7200 & 1700 SERIES**

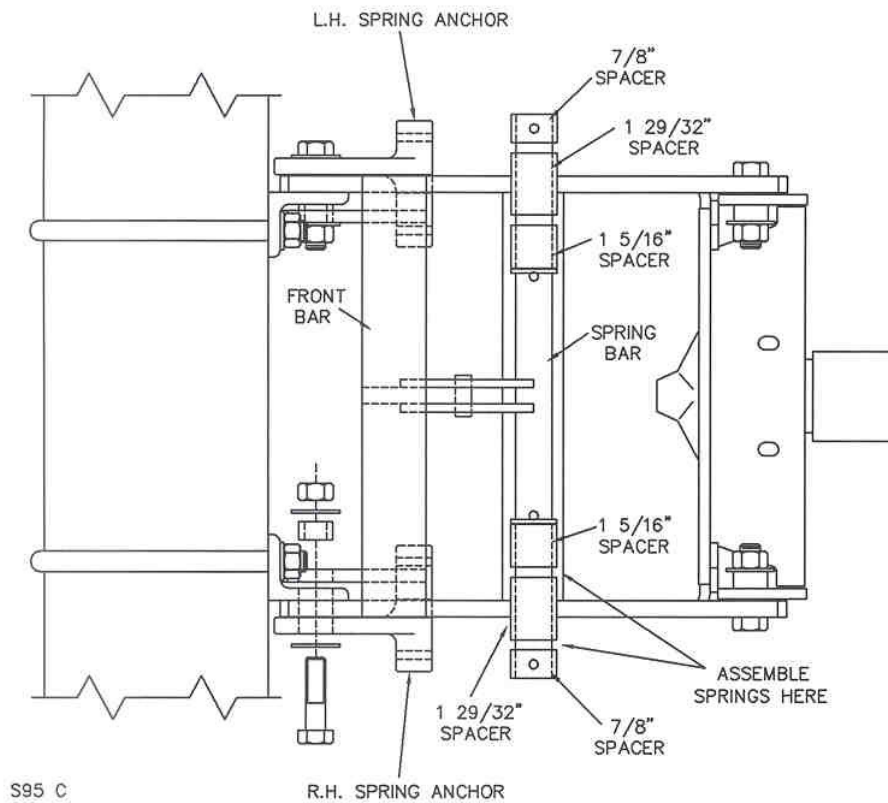

**PARTS ARRANGEMENT FOR J.D. 7000**

# PARTS IDENTIFICATION

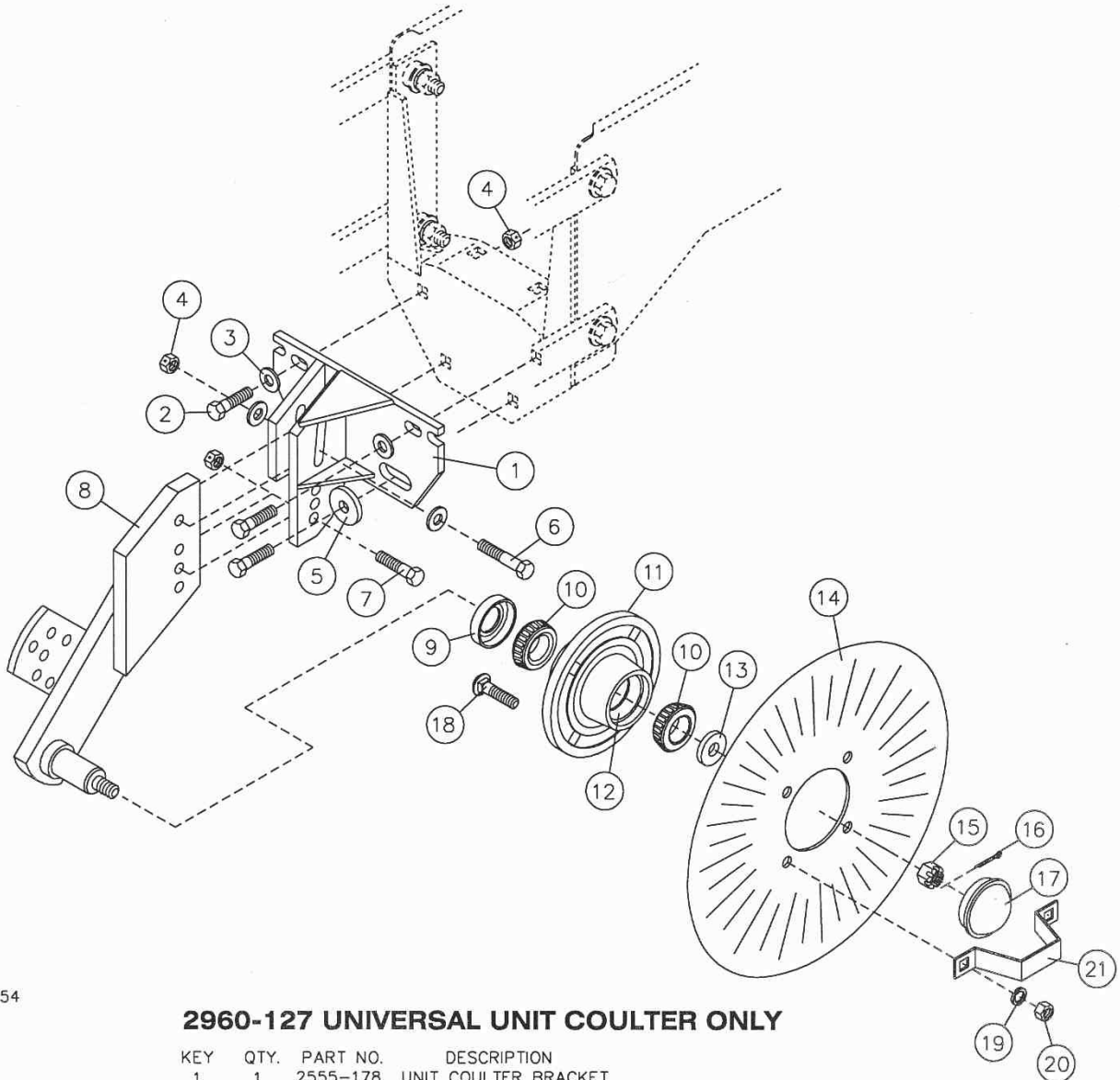

1154

## 2960-127 UNIVERSAL UNIT COULTER ONLY

KEY	QTY.	PART NO.	DESCRIPTION
1	1	2555-178	UNIT COULTER BRACKET
2	3	2502-294	1/2-13 X 1 1/2" HHCS GR.5 ZP.
3	4	2526-355	1/2" FLATWASHER, HARDENED, P.C.
4	5	2520-357	1/2-13 LOCK HEX NUT ZP.
5	1	2526-402	9/16 I.D. X 1 3/4 O.D. X 1/4" M.B. ZP.
6	1	2502-296	1/2-13 X 2 1/2" HHCS GR.5 ZP.
7	1	2502-351	1/2-13 X 2" HHCS GR.5 ZP.
8	1	2960-218	UNIVERSAL UNIT COULTER ARM W.A.
		2960-116	(INCLUDES 8-13, 15, 16 ,17)
9	1	2550-066	TRIPLE LIP SEAL, NTI #1812-4
10	2	2550-027	CONE, LM67048
11	1	2900-102	HUB SUB-ASSEMBLY
12	2	2550-029	CUP (PRE-ASSEM. W/NO. 11)
13	1	2526-449	5/8" FLATWASHER, 11/16 I.D. X 1 3/4 O.D. X 1/4"
14	1	2571-153	16" BUBBLE FLUTE COULTER BLADE
	1	2571-156	16" WAVY COULTER BLADE, 8 FLUTE
	1	2571-161	16" RIPPLE FLUTE COULTER BLADE
	1	2571-162	16" WAVY BLADE, 13 FLUTE
	1	2571-164	14.56" DIA., WAVY COULTER BLADE, 8 FLUTE
	1	2571-166	14.56" WAVY COULTER BLADE, 25 FLUTE
	1	2571-172	16" WAVY BLADE, 25 FLUTE
	1	2571-206	16" SMOOTH BLADE
15	1	2520-469	5/8-18 SLOTTED HEX NUT, BLACK
16	1	2531-102	1/8 X 1 1/4" COTTER PIN, BLACK
17	1	2570-375	HUB CAP
18	4	2505-337	1/2-13 X 1 1/4" CAR. BOLT GR.5 ZP
19	4	2525-352	1/2 MED. LOCKWASHER ZP.
20	4	2520-352	1/2-13 HEX NUT ZP.
21	1	2987-301	HUB CAP RETAINER

REVISED 02/03/09

# PARTS IDENTIFICATION

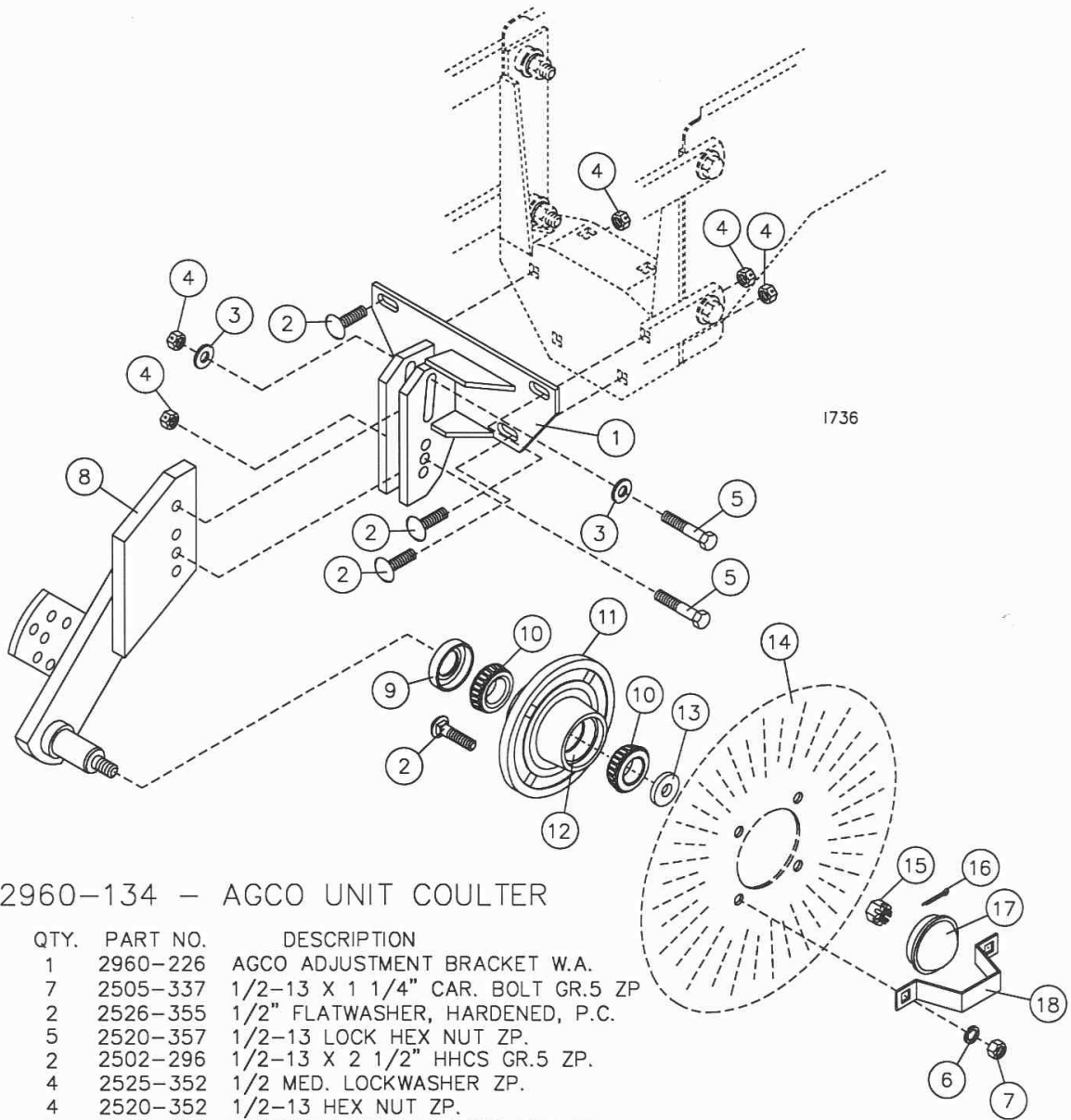

## 2960-134 - AGCO UNIT COULTER

KEY	QTY.	PART NO.	DESCRIPTION
1	1	2960-226	AGCO ADJUSTMENT BRACKET W.A.
2	7	2505-337	1/2-13 X 1 1/4" CAR. BOLT GR.5 ZP
3	2	2526-355	1/2" FLATWASHER, HARDENED, P.C.
4	5	2520-357	1/2-13 LOCK HEX NUT ZP.
5	2	2502-296	1/2-13 X 2 1/2" HHCS GR.5 ZP.
6	4	2525-352	1/2 MED. LOCKWASHER ZP.
7	4	2520-352	1/2-13 HEX NUT ZP.
8	1	2960-218	UNIVERSAL UNIT COULTER ARM W.A.
9	1	2550-066	TRIPLE LIP SEAL, NTI #1812-4
10	2	2550-027	CONE, LM67048
11	1	2900-102	HUB SUB-ASSEMBLY
12	2	2550-029	CUP (PRE-ASSEM. W/NO. 11)
13	1	2526-449	5/8" FLATWASHER, 11/16 I.D. X 1 3/4 O.D. X 1/4
14	1	2571-153	16" BUBBLE FLUTE COULTER BLADE (2960-134-B)
	1	2571-156	16" WAVY COULTER BLADE, 8 FLUTE (2960-134-W)
	1	2571-161	16" RIPPLE FLUTE COULTER BLADE (2960-134-R)
	1	2571-162	16" WAVY BLADE, 13 FLUTE (2960-134-SW)
	1	2571-172	16" WAVY BLADE, 25 FLUTE (2960-134-MW)
	1	2571-206	16" SMOOTH BLADE (2960-134-S)
15	1	2520-469	5/8-18 SLOTTED HEX NUT, BLACK
16	1	2531-102	1/8 X 1 1/4" COTTER PIN, BLACK
17	1	2570-375	HUB CAP
18	1	2987-301	HUB CAP RETAINER

REVISED 03/19/08

# PARTS IDENTIFICATION

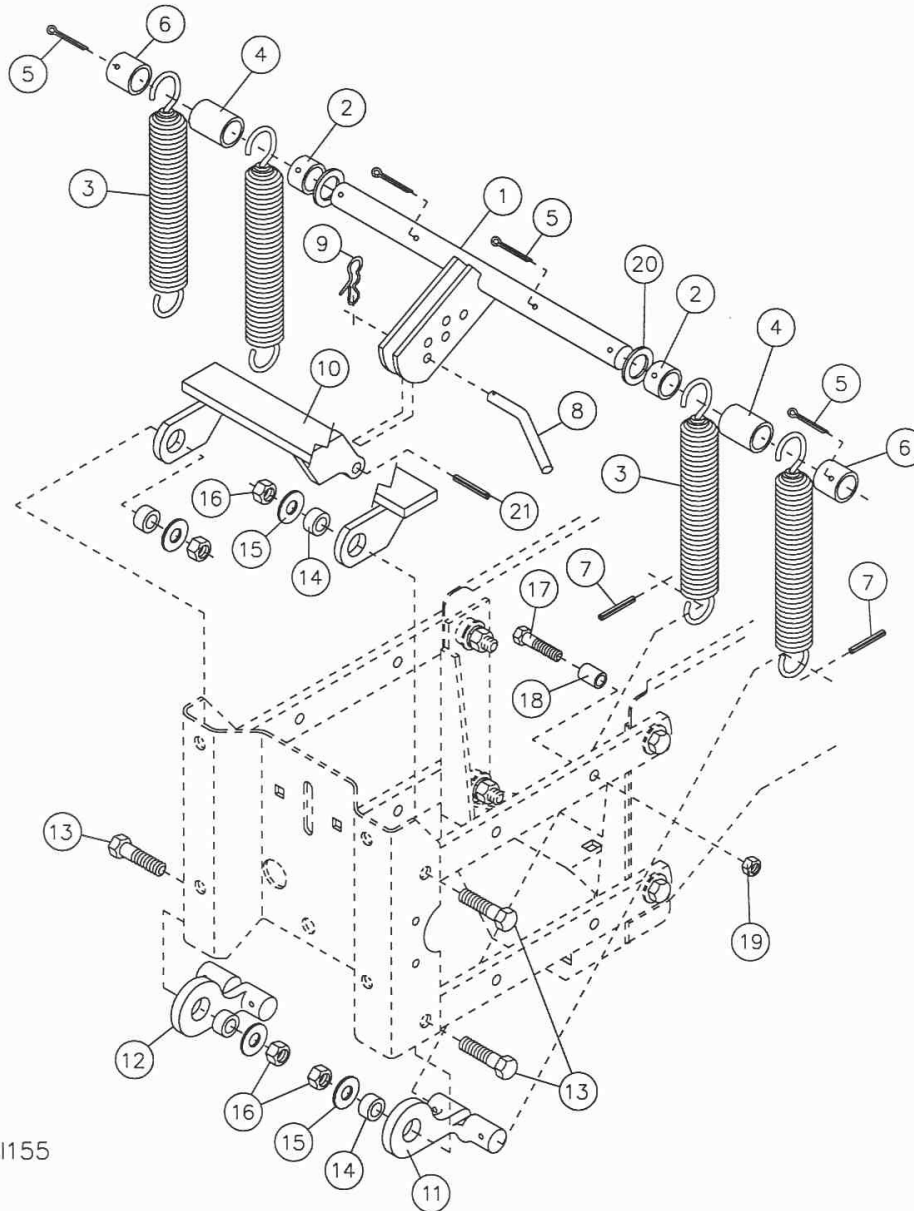

I155

## 2960-126 UNIVERSAL SPRING KIT ONLY

KEY	QTY.	PART NO.	DESCRIPTION
1	1	2960-227	SPRING BAR W.A (6/02)
2	2	2960-353	SPACER, 7/8" ZP.
3	4	2960-373	EXT. SPRING, 1 5/8 O.D. X .26 WIRE
4	2	2960-352	SPACER, 1 29/32" ZP.
5	4	2531-125	1/4 X 1 3/4" COTTER PIN ZP.
6	2	2960-351	SPACER, 1 5/16" ZP.
7	4	2530-153	1/4 X 2" ROLL PIN ZP.
8	1	2960-359	SPRING ADJUSTMENT PIN, ZP.
9	1	2570-448	1/8" BOWTIE LOCKING COTTER ZYD.
10	1	2960-221	FRONT BAR W.A.
11	1	2960-361	SPRING ANCHOR, L.H.
12	1	2960-360	SPRING ANCHOR, R.H.
13	4	2502-393	5/8-11 X 2 1/2" HHCS GR.5 ZP.
14	4	2960-354	PIVOT SPACER, 9/16" ZP.
15	4	2526-451	5/8 STD. FLATWASHER ZP.
16	4	2520-459	5/8-11 LOCK HEX NUT ZP.
17	2	2502-351	1/2-13 X 2 HHCS GR.5 ZP
18	2	2960-372	SPRING STOP, ZP
19	2	2520-357	1/2-13 LOCK HEX NUT ZP
20	2	2527-557	1-1/BID X 1-3/40D X 10GA MA BU
21	1	2530-219	1/2 X 2 ROLL PIN, BLACK

UPDATED 05-16-08

## TROUBLESHOOTING

Problem	Cause	Solution
<b>Cannot adjust coulter depth shallow enough.</b>	<b>Planter frame not set correctly.</b>	<b>Ensure that in operation the planter frame is at correct height (20"-22") and level the toolbar, refer to opposite page.</b>
Cannot adjust coulter deep enough.	Coulter blade worn too small.	Replace coulter blade.
Coulter will not penetrate.	Lack of spring tension.	Increase spring tension.
Coulter penetrates too much.	Excessive spring down pressure.	Reduce spring tension.
Seed placement is too deep.	Coulter blade set too deep relative to openers.	Shallow up coulter depth.
Optional wavy blade disturbs too much soil.	Soil too damp or loose.	Reduce ground speed.
Drive chain rubs on springs.	Close fitting parts.	Not detrimental to operation of planter.
No spring tension.	Planter frame not set correctly.	Check planter frame settings, see above.
	Spring adjustment pin not installed properly	Check installation of pin.

# NOTES

# NOTES

# Our name Is getting known

Just a few years ago, Yetter products were sold primarily to the Midwest only. Then we embarked on a program of expansion and moved into the East, the South, the West and now north into Canada. We're even getting orders from as far away as Australia and Africa.

So, when you buy Yetter products . . .you're buying a name that's recognized. A name that's known and respected. A name that's become a part of American agriculture and has become synonymous with quality and satisfaction in the field of conservation tillage.

Thank you.

**YETTER MANUFACTURING CO.**

Colchester, IL 62326-0358 ☎ 309/776-4111

Toll Free 800/447-5777

Fax 309/776-3222

Website: [www.yetterco.com](http://www.yetterco.com)

E-mail: [info@yetterco.com](mailto:info@yetterco.com)